

1

Model Number Code

Prefix Options

Stroke

Action

Suffix Options

Leave blank if none desired

C - **721** - **X** - **MR**

Metric M
See pages 1.7, 1.55 & 1.58

Bore Code
3" 721
76.2mm 721

Standard Strokes			
Original Series			
Action	X XK XDR XDRK	O ODR	OP
Stroke			
1/8	AB	AB	AB
1/4	AA	AA	AA
1/2	A	A	A
3/4	B	B	B
1	C	C	C
1 1/2	D	D	-
2	E	-	-
3	F	-	-
4	G	-	-

"T" Series Includes PTFE piston bearing			
Action	X XK	O	OP
Stroke			
1/4	TA	TA	TA
1/2	TB	TB	TB
3/4	TC	TC	TC
1 1/4	TD	TD	-
1 3/4	TE	-	-
2 3/4	TF	-	-
3 3/4	TG	-	-

Grey shading indicates sensors are not available.

Strokes are NOT affected by magnetic piston Option "E"

Action	
Single rod	
Double acting	-X
Double acting, Nonrotating	
Internal guide pins - 150 psi max	-XK
Single acting, spring retracted	-O
Single acting, spring extended	-OP
Double rod	
Double acting	-XDR
Double acting, Nonrotating	
Internal guide pins - 150 psi max	-XDRK
Single acting, spring retracted	-ODR

See pages 1.5 & 1.6 for Action Information.
See pages 1.54 & 1.57 for Standard Specifications

Suffix Options	
Male rod thread: Single rod	-MR
Double rod, rod end	-MR
Double rod, cap end	-MR1
Double rod, both ends	-MR2
PTFE seals	-T
Viton seals	-V
Quad seals	-Q
External guide, nonrotating for load guiding (See page 1.65)	-G
Hydraulic:	
Standard cover	-H
Thick cover	-HHC
Air service:	
Thick cover	-HC
1/4 NPT ports	-P14
Hole thru double rod shaft: 5/32" hole	-16
Plus size: 1/4" hole	-25
150 psi max	
Finish: ProCoat™ (Electroless Nickel)	-N
Stroke collar:	
1/4"	-C1 1/8"
	-C2 3/8"
1/2"	-C3 5/8"
	-C4 7/8"
3/4"	-C5
	-C6
Sound limiters:	
Rod end	-LF
Cap end	-LR
Both ends	-LFR
Rubber Bumpers:	
Rod end	-BF
Cap end	-BR
Both ends	-BFR
Adjustable extend stroke (Full stroke adjustment is standard)	-AS
Adjustable retract stroke (Over 1" adjustment add desired length, e.g. -RS2)	-RS
Clevis mount: Ports in-line with slot	-PM
Ports 90° to slot	-SM
Magnetic piston & sensor mounting slot(s) Order sensors separately. See page 1.14. Stroke length determines number of mounting slots. See page 1.14, 1.56, 1.58	-E

See pages 1.3 – 1.15 for general option information and pages 1.55, 1.56 & 1.58 for option specifications of 3" bore models.

HOW TO ORDER

- Under **Stroke** – select letter(s) for desired Series and Stroke.
 - Under **Bore** – select **721** for 3" bore.
Seven Other Bore Sizes are Available
- | Bore | Bore Code | See page |
|--------|-----------|----------|
| 1/2" | 5 | 1.17 |
| 3/4" | 7 | 1.23 |
| 1 1/4" | 121 | 1.29 |
| 1 5/8" | 221 | 1.35 |
| 2" | 321 | 1.41 |
| 2 1/2" | 521 | 1.47 |
| 4" | 1221 | 1.59 |
- Under **Action** – select letter(s) for desired action.
 - Under **Prefix & Suffix Options** – select letter(s) for desired options and add to model number.

EXAMPLES

- A-721-X**
Original Series, 1/2" stroke - 3" Bore - Single Rod, Double Acting
- TC-721-X-MR**
"T" Series, 3/4" Stroke - 3" Bore - Single Rod, Double Acting - Male Rod Thread

A complete library of cylinder CAD drawings is available from your local Fabco-Air Distributor or from the Fabco-Air web site – <http://www.fabco-air.com>

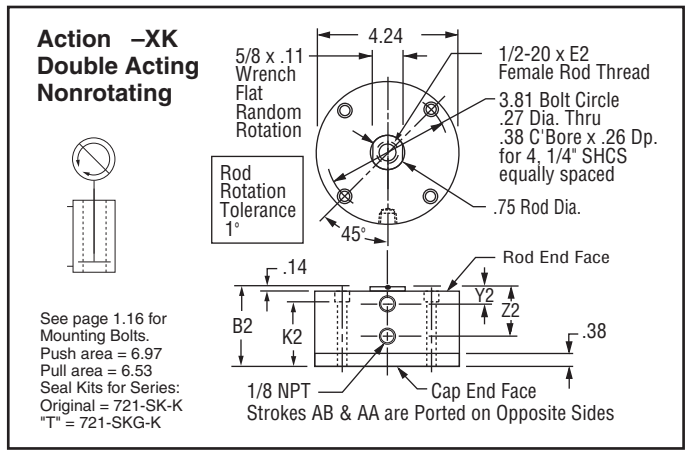
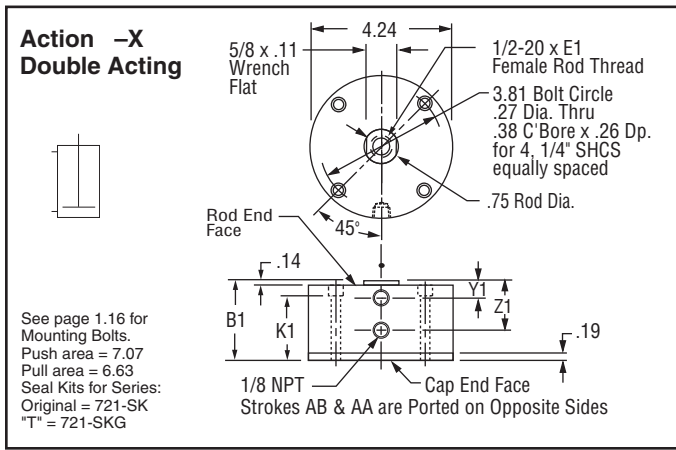

Original Series

"T" Series

Stroke, Inches	1/8	1/4	1/2	3/4	1	1 1/2	2	3	4	1/4	1/2	3/4	1 1/4	1 3/4	2 3/4	3 3/4	
Stroke, Letter	AB	AA	A	B	C	D	E	F	G	TA	TB	TC	TD	TE	TF	TG	
Action -X Double Acting										Action -X Double Acting							
B1	1.52	1.64	1.89	2.14	2.39	2.89	3.39	4.39	5.39	1.89	2.14	2.39	2.89	3.39	4.39	5.39	
E1	.63	.63	.63	.88	.88	.88	.88	.88	.88	.63	.88	.88	.88	.88	.88	.88	
K1	1.12	1.24	1.49	1.74	1.99	2.49	2.99	3.99	4.99	1.49	1.74	1.99	2.49	2.99	3.99	4.99	
Y1	.52	.52	.52	.64	.64	.64	.64	.64	.64	.52	.64	.64	.64	.64	.64	.64	
Z1	.95	1.08	1.33	1.58	1.83	2.33	2.83	3.83	4.83	1.33	1.58	1.83	2.33	2.83	3.83	4.83	
Weight, lb.	1.89	1.97	2.18	2.36	2.57	2.98	3.28	4.22	5.03	2.49	2.68	2.89	3.30	3.70	4.54	5.40	
Action -XK Double Acting, Nonrotating										Action -XK Double Acting, Nonrotating							
B2	1.71	1.83	2.08	2.33	2.58	3.08	3.58	4.58	5.58	2.08	2.33	2.58	3.08	3.58	4.58	5.58	
E2	.63	.63	.63	.88	.88	.88	.88	.88	.88	.63	.88	.88	.88	.88	.88	.88	
K2	1.31	1.43	1.68	1.93	2.18	2.68	3.18	4.18	5.18	1.68	1.93	2.18	2.68	3.18	4.18	5.18	
Y2	.52	.52	.52	.64	.64	.64	.64	.64	.64	.52	.64	.64	.64	.64	.64	.64	
Z2	.95	1.08	1.33	1.58	1.83	2.33	2.83	3.83	4.83	1.33	1.58	1.83	2.33	2.83	3.83	4.83	
Weight, lb.	2.15	2.24	2.45	2.64	2.86	3.28	3.59	4.56	5.40	2.77	2.96	3.18	3.60	3.91	4.88	5.72	
Action -O Single Acting, Spring Retracted										Action -O Single Acting, Spring Retracted							
B3	1.52	1.64	1.89	2.14	2.39	4.39	NA*	NA*	NA*	1.89	2.14	2.39	4.39	NA*	NA*	NA*	
E3	.63	.63	.63	.88	.88	.88	NA*	NA*	NA*	.63	.88	.88	.88	NA*	NA*	NA*	
K3	1.12	1.24	1.49	1.74	1.99	3.99	NA*	NA*	NA*	1.49	1.74	1.99	3.99	NA*	NA*	NA*	
Y3	Rod End Face Vent						.64	NA*	NA*	NA*	Rod End Face Vent			.64	NA*	NA*	NA*
Z3	.95	1.08	1.33	1.58	1.83	3.83	NA*	NA*	NA	1.33	1.58	1.83	3.83	NA*	NA*	NA*	
Weight, lb. 1.20	1.92	2.11	2.29	2.51	4.36	NA*	NA*	NA*	2.43	2.61	2.83	4.68	NA*	NA*	NA*	NA*	
Preload, lb. 12.0	12.0	6.5	5.0	4.7	7.3	NA*	NA*	NA*	11.7	10.6	7.9	9.5	NA*	NA*	NA*	NA*	
End of Stroke, lb.	18.0	18.5	15.5	15.5	20.0	20.0	NA*	NA*	NA*	17.0	19.3	20.0	20.0	NA*	NA*	NA*	
Action -OP Single Acting, Spring Extended										Action -OP Single Acting, Spring Extended							
B4	2.08	2.33	2.83	3.33	3.83	NA*	NA*	NA*	NA*	2.58	3.08	3.58	NA*	NA*	NA*	NA*	
E4	.63	.63	.63	.88	.88	NA*	NA*	NA*	NA*	.63	.88	.88	NA*	NA*	NA*	NA*	
K4	1.55	1.68	1.93	2.18	2.43	NA*	NA*	NA*	NA*	1.93	2.18	2.43	NA*	NA*	NA*	NA*	
Y4	.65	.77	1.02	1.39	1.64	NA*	NA*	NA*	NA*	.77	1.14	1.39	NA*	NA*	NA*	NA*	
Z4	1.08	1.33	1.83	2.33	2.83	NA*	NA*	NA*	NA*	1.58	2.08	2.58	NA*	NA*	NA*	NA*	
Weight, lb. 2.49	2.60	2.69	2.99	3.20	NA*	NA*	NA*	NA*	3.01	3.31	3.52	NA*	NA*	NA*	NA*	NA*	
Preload, lb. 6.2	12.0	6.5	5.0	5.2	NA*	NA*	NA*	NA*	11.7	10.6	8.5	NA*	NA*	NA*	NA*	NA*	
End of Stroke, lb.	12.0	18.5	15.5	15.5	20.5	NA*	NA*	NA*	NA*	17.1	19.3	20.8	NA*	NA*	NA*	NA*	

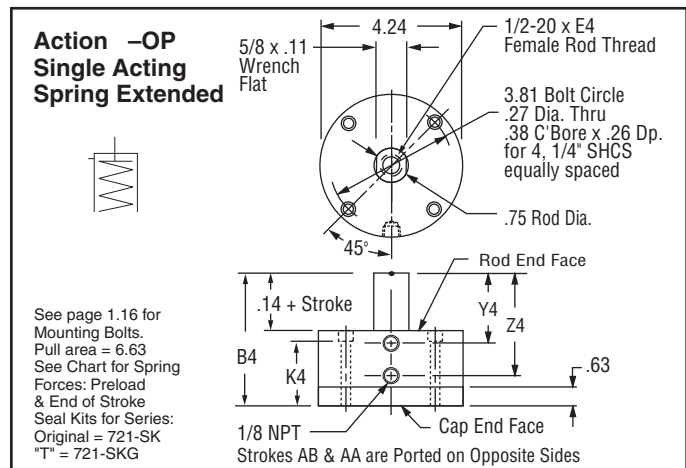
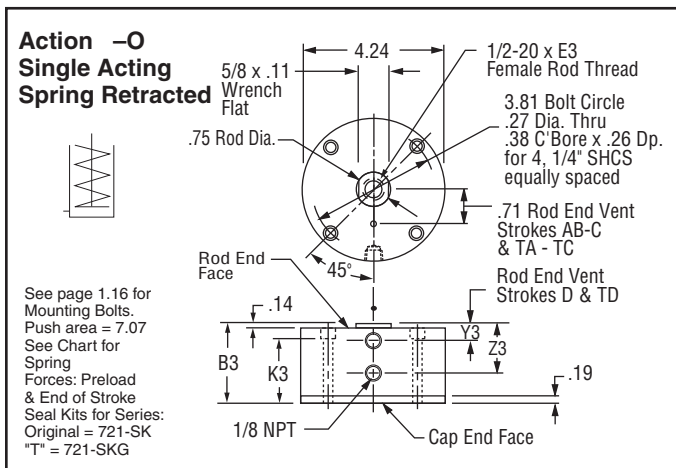

Prefix Option -M Metric Cylinder & Rod Thread 76.2mm Bore

Available on Original and "T" Series with Actions: -X, -XK, -O, -OP
Also see *Option Information* on page 1.7.

Original Series									
Stroke mm	3.2	6.4	12.7	19.1	25.4	38.1	50.8	76.2	101.6
Stroke Letter	AB	AA	A	B	C	D	E	F	G

"T" Series							
Stroke mm	6.4	12.7	19.1	31.8	44.5	69.9	95.3
Stroke Letter	TA	TB	TC	TD	TE	TF	TG

Mounting Holes
6.7mm Diameter Thru
10.3mm C Bore x 6.4mm Dp.
4 Places for M6 SHCS

Thread Pitches
M6 = 1.0mm
M12 = 1.75mm

Conversion Factor
Inches x 25.4 = mm

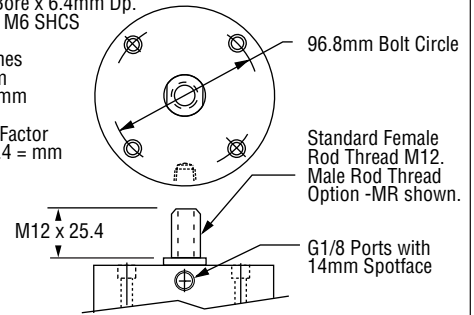

The **Suffix Options** charted on the right are available on Original and "T" Series with the Actions indicated (✓). They require no dimensional changes from the Standard Specifications on page 1.54.
- Also see *Option Information* on pages 1.7 thru 1.15.

	T	V	Q	H	N	C1-C7	LF	LR	LFR	BF	BR	BFR	P14
-X	✓	✓	✓	✓	✓	✓	✓	✓	✓	✓	✓	✓	✓
-XK	NA	✓	✓	✓	✓	✓	NA	✓	✓	✓	✓	✓	✓
-O	NA	✓	✓	✓	✓	NA	NA	✓	NA	NA	NA	NA	✓
-OP	NA	✓	✓	✓	✓	✓	✓	✓	✓	✓	NA	NA	✓

Suffix Options -PM & -SM Clevis Mount

Available on Original and "T" Series with Actions: -X, -XK, -O, -OP

Also see *Option Information* on page 1.13.

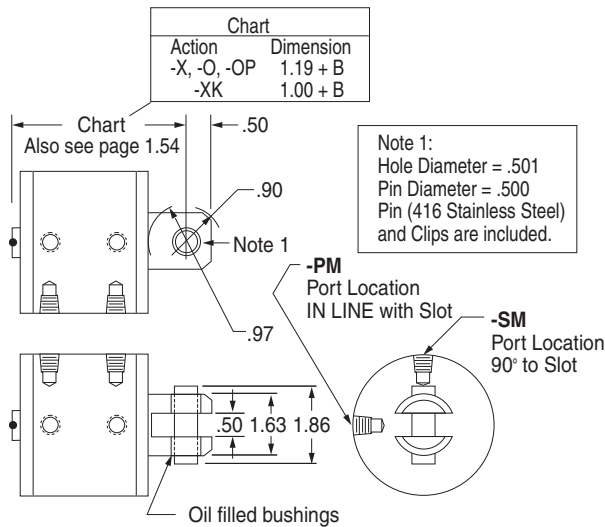

EM-521 Eye Bracket Kit

Mates with Clevis Mount shown on the left.
Order separately.

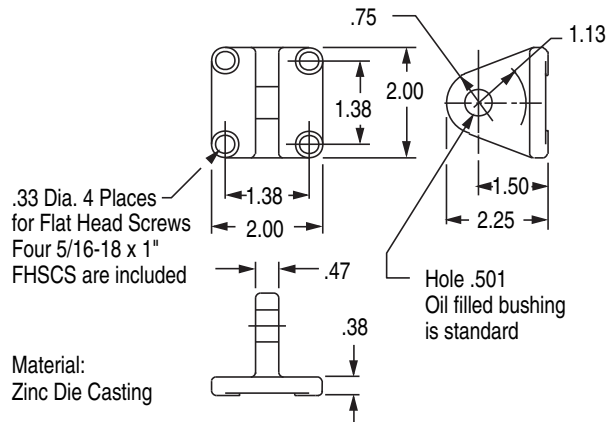

EM-121 Eye Bracket Kit

Mates with RC-56 Rod Clevis shown on the left.
Order separately.

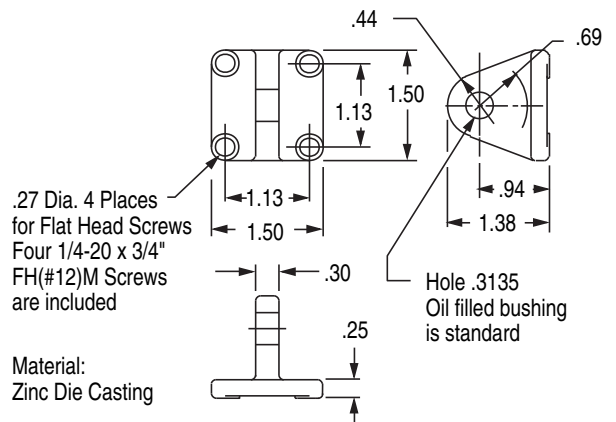

RC-56 Rod Clevis and Pin

Threaded Stud mates with Female Rod thread in the **Pancake®** Cylinders.
Slot and Pin Mate with EM-121 Eye Bracket shown on the right.

Materials:
Clevis - Steel, Black Oxide
Stud - Steel
Pin - 416 Stainless Steel
Pin & Clips are included

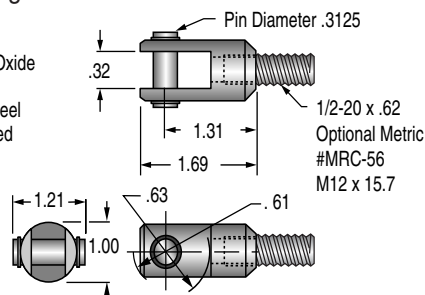

Suffix Option -HHC Hydraulic & -HC Air

Available on Original and "T" Series with Action -X, -O.

Also see *Option Information* on page 1.9 for Pressure and Mounting details.

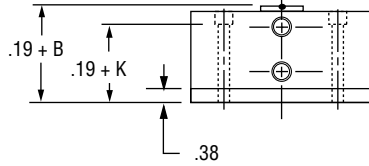

Suffix Option -MR Male Rod Thread

Available on Original and "T" Series with Actions: -X, -XK, -O, -OP. Also see *Option Information* on page 1.8.

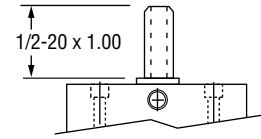

Suffix Option -RS Adjustable Retract Stroke

Available on Original and "T" Series with Actions: -X, -XK, -O, -OP. Also see *Option Information* on page 1.11.

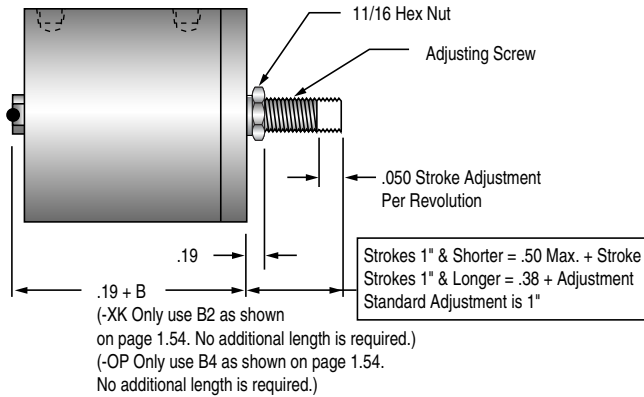

Suffix Option -E Specifies Magnetic Piston and Dovetail Mounting Slot(s)

Strokes are **NOT** affected by magnetic piston.

– Sensors Must be Ordered Separately See Sensor Models Available page 1.14

3" (721) Bore

Sensors available for "AA" & "TA" strokes and longer. Stroke AA is ported on opposite sides.

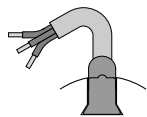

1/4" 60° Dovetail Profile of Sensor & Mounting Slot.

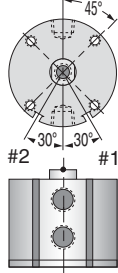

Quick Reference to Standard Strokes

Use the appropriate Stroke Letter in the Model Number

	Available on Original Series		Available on "T" Series	
	Stroke	Action X, XK	Stroke	Action X, XK
Sensor Slots at Positions #1 and #2	1/4	-----AA	1/4	-----TA
	1/2	-----A	1/2	-----TB
	3/4	-----B	3/4	-----TC
	1	-----C		
Sensor Slot at Position #1 only	1 1/2	-----D	1 1/4	-----TD
	2	-----E	1 3/4	-----TE
	3	-----F	2 3/4	-----TF
	4	-----G	3 3/4	-----TG

Suffix Option -AS Adjustable Extend Stroke

Available on Original Series with Actions: -X, -XK, -O. Also see *Option Information* on page 1.11.

Stroke Inches	1/8	1/4	1/2	3/4	1	1-1/2	2	3	4
Stroke Letter	AB	AA	A	B	C	D	E	F	G
Actions: -X, -XK	BB	2.08	2.20	2.45	2.70	2.95	3.45	3.95	4.95
Actions: -O	BB	2.08	2.20	2.45	2.70	2.95	3.45	3.95	4.95
	C	1.67	1.91	2.41	2.91	3.41	4.41	5.41	7.41
	D	0.63	0.75	1.00	1.25	1.50	2.00	2.50	3.50
	E	0.88	1.00	1.25	1.50	1.75	2.25	2.75	3.75

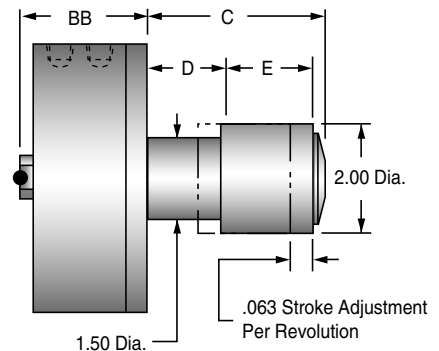

1

Action -XDR Original Series Double Rod, Double Acting

See page 1.16 for
Mounting Bolts
Force Area = 6.63
Seal Kit = 721-SK

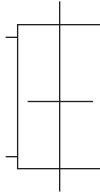

Stroke, Inches	1/8	1/4	1/2	3/4	1	1-1/2	2	3	4
Stroke, Letter	AB	AA	A	B	C	D	E	F	G
B	2.08	2.20	2.45	2.70	2.95	3.45	3.95	4.95	5.95
E	.63	.63	.63	.88	.88	.88	.88	.88	.88
K	1.68	1.80	2.10	2.30	2.55	3.10	3.55	4.55	5.55
Y	.52	.52	.52	.64	.64	.64	.64	.64	.64
Z	.95	1.08	1.33	1.58	1.83	2.33	2.83	3.83	4.83
Weight, lb.	2.84	2.95	3.16	3.39	3.61	4.09	4.53	5.50	6.47

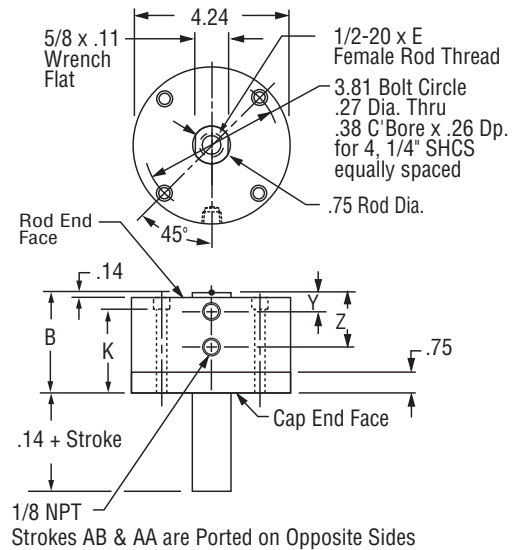

Action -XDRK Original Series Double Rod, Double Acting, Nonrotating

See page 1.16 for
Mounting Bolts
Force Area = 6.53
Seal Kit = 721-SK-K

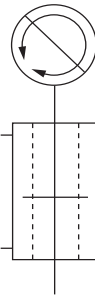

Stroke, Inches	1/8	1/4	1/2	3/4	1	1-1/2	2	3	4
Stroke, Letter	AB	AA	A	B	C	D	E	F	G
B	2.08	2.20	2.45	2.70	2.95	3.45	3.95	4.95	5.95
E	.63	.63	.63	.88	.88	.88	.88	.88	.88
K	1.68	1.80	2.10	2.30	2.55	3.10	3.55	4.55	5.55
Y	.52	.52	.52	.64	.64	.64	.64	.64	.64
Z	.95	1.08	1.33	1.58	1.83	2.33	2.83	3.83	4.83
Weight, lb.	3.10	3.21	3.43	3.67	3.90	4.39	4.84	5.84	6.84

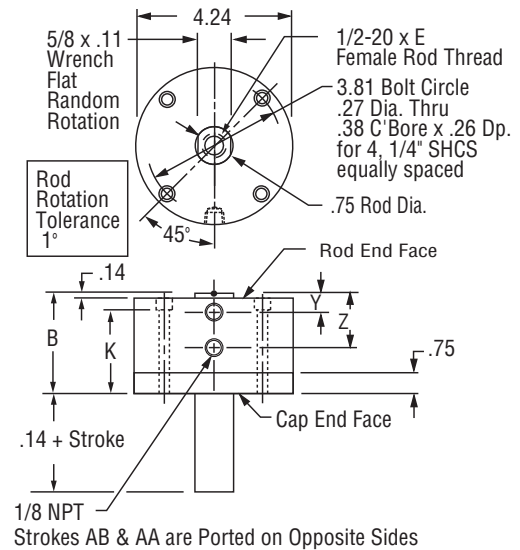

Action -ODR Original Series Double Rod, Single Acting, Spring Retracted

See page 1.16 for
Mounting Bolts
Force Area = 6.63
Seal Kit = 721-SK

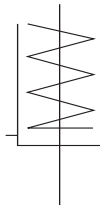

Stroke, Inches	1/8	1/4	1/2	3/4	1	1-1/2
Stroke, Letter	AB	AA	A	B	C	D
B	2.08	2.20	2.45	2.70	2.95	4.95
E	.63	.63	.63	.88	.88	.88
K	1.68	1.80	2.10	2.30	2.55	4.55
Y	Rod End Face Vent					.64
Z	.95	1.08	1.33	1.58	1.83	3.83
Weight, lb.	2.77	2.88	3.10	3.31	3.54	5.64
Spring Return Forces, lb.						
Preload	12.0	12.0	6.5	5.0	4.7	7.3
End of Stroke	18.0	18.5	15.5	15.5	20.0	20.0

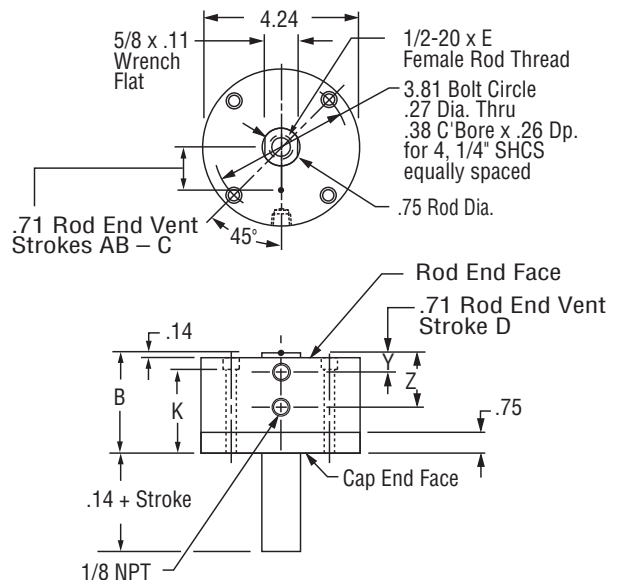

Prefix Option -M Metric Cylinder & Rod Thread, 76.2mm Bore

Available on Original Series with Actions: -XDR, -XDRK, -ODR

Also see *Option Information* on page 1.7.

Stroke mm	3.2	6.4	12.7	19.1	25.4	38.1	50.8	76.2	101.6
Stroke Letter	AB	AA	A	B	C	D	E	F	G

Mounting Holes
6.7mm Diameter Thru
10.3mm C' Bore x 6.4mm Dp.
4 Places for M6 SHCS

Thread Pitches
M6 = 1.0mm
M12 = 1.75mm

Conversion Factor
Inches x 25.4 = mm

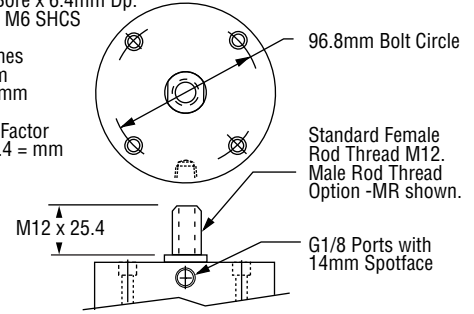

The **Suffix Options** charted on the right are available on Original Series with the Actions indicated (✓). They require no dimensional changes from the Standard Specifications on page 1.57. – Also see *Option Information* on pages 1.7 thru 1.15.

	T	V	Q	H	N	C1-C7	LF	LR	LFR	BF	BR	BFR	P14	16	25
-XDR	✓	✓	✓	✓	✓	✓	✓	✓	✓	✓	✓	✓	✓	✓	✓
-XDRK	NA	✓	✓	✓	✓	✓	NA	✓	NA	✓	✓	✓	✓	✓	✓
-ODR	NA	✓	✓	✓	✓	NA	NA	✓	NA	NA	✓	NA	✓	✓	✓

Suffix Options -MR, -MR1, -MR2 Male Rod Thread

Available on Original Series with Actions -XDR, -XDRK, -ODR.

- For Rod End only use –MR
- For Cap End only use –MR1
- For Both Ends –MR2

Also see *Option Information* on Page 1.8

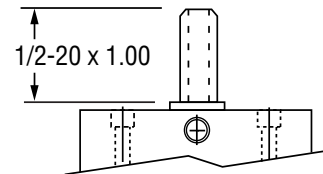

Suffix Option -E Specifies Magnetic Piston and Dovetail Mounting Slot(s)

Strokes are NOT affected by magnetic piston.

**– Sensors Must be Ordered Separately
See Sensor Models Available page 1.14**

3" (721) Bore

Sensors available for "AA" strokes and longer.
Stroke AA is ported on opposite sides.

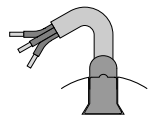

1/4" 60° Dovetail Profile of Sensor & Mounting Slot.

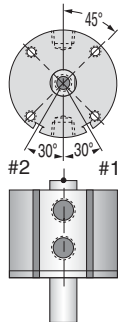

Quick Reference to Standard Strokes
Use the appropriate Stroke Letter in the Model Number

Available on Original Series

Sensor Slots at Positions #1 and #2	Action	
	Stroke	XDR, XDRK
Sensor Slots at Positions #1 and #2	1/4 -----	AA
	1/2 -----	A
	3/4 -----	B
	1 -----	C
Sensor Slot at Position #1 only	1 1/2 -----	D
	2 -----	E
	3 -----	F
	4 -----	G