

Pancake® Cylinders 1 5/8" (221) Bore Model Number

1

Model Number Code

Prefix Options

Leave blank if none desired

Stroke

Bore

Action

Suffix Options

D

221

X

MR

Metric M
See pages 1.7, 1.37 & 1.40

Bore	Code
1 5/8"	221
41.3mm	221

Standard Strokes			
Original Series			
Action	X XK XDR XDRK	O ODR	OP
Stroke			
1/8	AA	AA	AA
1/4	A*	A	A
1/2	B	B	B
3/4	C	C	C
1	D	D	D
1 1/2	E	E	-
2	F	-	-
3	G	-	-
4	H	-	-

"T" Series Includes PTFE piston bearing			
Action	X XK	O	OP
Stroke			
1/4	TB	TB	TB
1/2	TC	TC	TC
3/4	TD	TD	TD
1 1/4	TE	-	-
1 3/4	TF	-	-
2 3/4	TG	-	-
3 3/4	TH	-	-

Grey shading indicates sensors are not available.

Strokes are NOT affected by magnetic piston Option "E"

Action	
Single rod	
Double acting	-X
Double acting, Nonrotating	
Internal guide pins - 150 psi max	-XK
Single acting, spring retracted	-O
Single acting, spring extended	-OP
Double rod	
Double acting	-XDR
Double acting, Nonrotating	
Internal guide pins - 150 psi max	-XDRK
Single acting, spring retracted	-ODR

See pages 1.5 & 1.6 for Action Information.
See pages 1.36 & 1.39 for Standard Specifications

Suffix Options	
Male rod thread: Single rod	-MR
Double rod, rod end	-MR
Double rod, cap end	-MR1
Double rod, both ends	-MR2
PTFE seals	-T
Viton seals	-V
Quad seals	-Q
External guide, nonrotating for load guiding (See page 1.65)	-G
Hydraulic:	
Standard cover	-H
Thick cover	-HHC
Air service: Thick cover	-HC
1/4 NPT ports	-P14
Hole thru double rod shaft: 1/8" hole	-13
Plus size: 1/4" hole	-25
150 psi max	
Finish: ProCoat™ (Electroless Nickel)	-N
Stroke collar:	
1/4"	1/8" -C1
1/2"	3/8" -C3
3/4"	5/8" -C5
	7/8" -C7
Sound limiters:	
Rod end	-LF
Cap end	-LR
Both ends	-LFR
Rubber Bumpers:	
Rod end	-BF
Cap end	-BR
Both ends	-BFR
Adjustable extend stroke (Full stroke adjustment is standard)	-AS
Adjustable retract stroke (Over 1" adjustment add desired length, e.g. -RS2)	-RS
Clevis mount: Ports in-line with slot	-PM
Ports 90° to slot	-SM
Eye mount: Ports in-line with tang	-EPM
Ports 90° to tang	-ESM
Threaded nose mount: Single rod	-F
Double rod, rod end	-F
Double rod, cap end	-F1
Double rod, both ends	-F2
Magnetic piston & sensor mounting slot(s)	-E
Order sensors separately. See page 1.14. Stroke length determines number of mounting slots. See page 1.14, 1.38, 1.40	

See pages 1.3 – 1.15 for general option information.
and pages 1.37, 1.38 & 1.40 for option specifications of 1 5/8" bore models.

HOW TO ORDER

- Under **Stroke** – select letter(s) for desired Series and Stroke.
 - Under **Bore** – select **221** for 1 5/8" bore.
Seven Other Bore Sizes are Available
- | Bore | Bore Code | See page |
|--------|-----------|----------|
| 1/2" | 5 | 1.17 |
| 3/4" | 7 | 1.23 |
| 1 1/8" | 121 | 1.29 |
| 2" | 321 | 1.41 |
| 2 1/2" | 521 | 1.47 |
| 3" | 721 | 1.53 |
| 4" | 1221 | 1.59 |
- Under **Action** – select letter(s) for desired action.
 - Under **Prefix & Suffix Options** – select letter(s) for desired options and add to model number.

EXAMPLES

B-221-X

Original Series, 1/2" stroke - 1 5/8" Bore - Single Rod, Double Acting

TC-221-O-MR

"T" Series, 1/2" Stroke - 1 5/8" Bore - Single Rod, Spring Retract - Male Rod Thread

*Note –
Sensors not available:
A-221-XK
A-221-XDRK

A complete library of cylinder CAD drawings is available from your local Fabco-Air Distributor or from the Fabco-Air web site – <http://www.fabco-air.com>

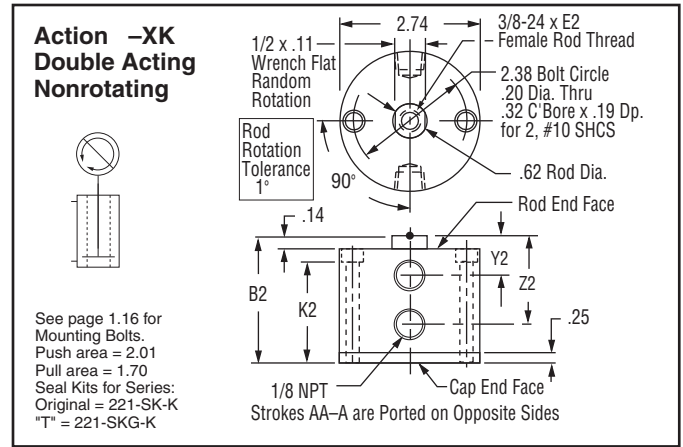
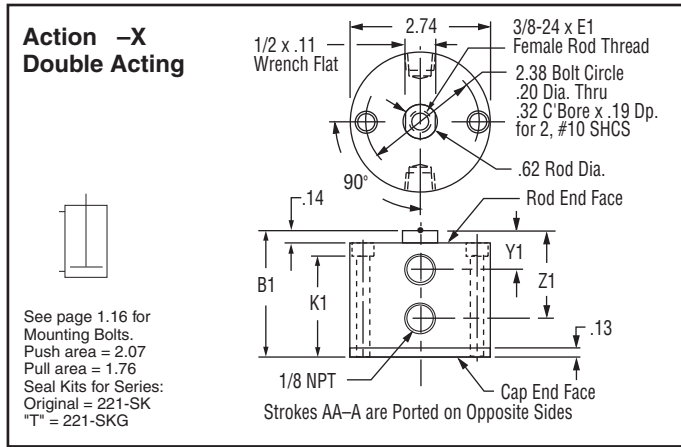

Original Series

Stroke, Inches	1/8	1/4	1/2	3/4	1	1 1/2	2	3	4
Stroke, Letter	AA	A	B	C	D	E	F	G	H
Action -X Double Acting									
B1	1.14	1.27	1.77	2.02	2.33	2.83	3.33	4.33	5.33
E1	.38	.44	.63	.63	.75	.75	.75	.75	.75
K1	.81	.94	1.44	1.69	2.00	2.50	3.00	4.00	5.00
Y1	.64	.64	.52	.52	.52	.52	.52	.52	.52
Z1	.64	.64	1.27	1.52	1.83	2.33	2.83	3.83	4.83
Weight, lb.	.60	.64	.93	1.06	1.19	1.43	1.66	2.14	2.60
Action -XK Double Acting, Nonrotating									
B2	1.27	1.40	1.90	2.15	2.46	2.96	3.46	4.46	5.46
E2	.38	.44	.63	.63	.75	.75	.75	.75	.75
K2	.94	1.06	1.57	1.82	2.13	2.63	3.13	4.13	5.13
Y2	.64	.64	.52	.52	.52	.52	.52	.52	.52
Z2	.64	.64	1.27	1.52	1.83	2.33	2.83	3.83	4.83
Weight, lb.	.68	.72	1.02	1.15	1.29	1.53	1.77	2.27	2.74
Action -O Single Acting, Spring Retracted									
B3	1.14	1.27	1.77	2.02	2.33	4.33	NA*	NA*	NA*
E3	.38	.44	.63	.63	.75	.75	NA*	NA*	NA*
K3	.81	.94	1.44	1.69	2.00	4.00	NA*	NA*	NA*
Y3	Rod End Face Vent					.52	NA*	NA*	NA*
Z3	.64	.77	1.27	1.52	1.83	3.83	NA*	NA*	NA*
Weight, lb.	.58	.63	.89	1.00	1.15	2.10	NA*	NA*	.95
Preload, lb.15.0	8.5	8.5	6.0	4.8	6.0	NA*	NA*	NA*	8.5
End of Stroke, lb.	20.0	20.0	20.0	18.0	20.0	18.0	NA*	NA*	NA*
Action -OP Single Acting, Spring Extended									
B4	1.65	1.89	2.64	3.14	3.83	NA*	NA*	NA*	NA*
E4	.38	.44	.63	.63	.75	NA*	NA*	NA*	NA*
K4	1.19	1.32	1.82	2.07	2.50	NA*	NA*	NA*	NA*
Y4	.77	.89	1.02	1.27	1.52	NA*	NA*	NA*	NA*
Z4	.77	.89	1.77	2.27	2.83	NA*	NA*	NA*	NA*
Weight, lb.	.81	.83	1.10	1.20	1.42	NA*	NA*	NA*	1.16
Preload, lb.8.5	4.5	5.5	4.0	4.8	NA*	NA*	NA*	NA*	4.5
End of Stroke, lb.	15.0	15.0	18.5	17.5	20.0	NA*	NA*	NA*	NA*

"T" Series

Stroke, Inches	1/4	1/2	3/4	1 1/4	1 3/4	2 3/4	3 3/4
Stroke, Letter	TB	TC	TD	TE	TF	TG	TH
Action -X Double Acting							
B1	1.77	2.02	2.33	2.83	3.33	4.33	5.33
E1	.63	.63	.75	.75	.75	.75	.75
K1	1.44	1.69	2.00	2.50	3.00	4.00	5.00
Y1	.52	.52	.52	.52	.52	.52	.52
Z1	1.27	1.57	1.83	2.33	2.83	3.83	4.83
Weight, lb.	.99	1.12	1.25	1.49	1.72	2.20	2.66
Action -XK Double Acting, Nonrotating							
B2	1.90	2.15	2.46	2.96	3.46	4.46	5.46
E2	.63	.63	.75	.75	.75	.75	.75
K2	1.57	1.82	2.13	2.63	3.13	4.13	5.13
Y2	.52	.52	.52	.52	.52	.52	.52
Z2	1.27	1.57	1.83	2.33	2.83	3.83	4.83
Weight, lb.	1.08	1.21	1.35	1.59	1.83	2.83	3.80
Action -O Single Acting, Spring Retracted							
B3	1.77	2.02	2.33	4.33	NA*	NA*	NA*
E3	.63	.63	.75	.75	NA*	NA*	NA*
K3	1.44	1.69	2.00	4.00	NA*	NA*	NA*
Y3	Rod End Face Vent			.52	NA*	NA*	NA*
Z3	1.27	1.57	1.83	3.83	NA*	NA*	NA*
Weight, lb.	1.06	1.21	2.16	NA*	NA*	NA*	NA*
Preload, lb.15.0	8.5	6.0	7.06	NA*	NA*	NA*	NA*
End of Stroke, lb.	20.0	20.0	18.0	20.0	NA*	NA*	NA*
Action -OP Single Acting, Spring Extended							
B4	2.39	2.89	3.58	NA*	NA*	NA*	NA*
E4	.63	.63	.75	NA*	NA*	NA*	NA*
K4	1.82	2.07	2.50	NA*	NA*	NA*	NA*
Y4	.77	1.02	1.27	NA*	NA*	NA*	NA*
Z4	1.52	2.07	2.58	NA*	NA*	NA*	NA*
Weight, lb.	1.26	1.48	NA*	NA*	NA*	NA*	NA*
Preload, lb.8.5	5.5	4.0	NA*	NA*	NA*	NA*	NA*
End of Stroke, lb.	15.0	18.5	17.5	NA*	NA*	NA*	NA*

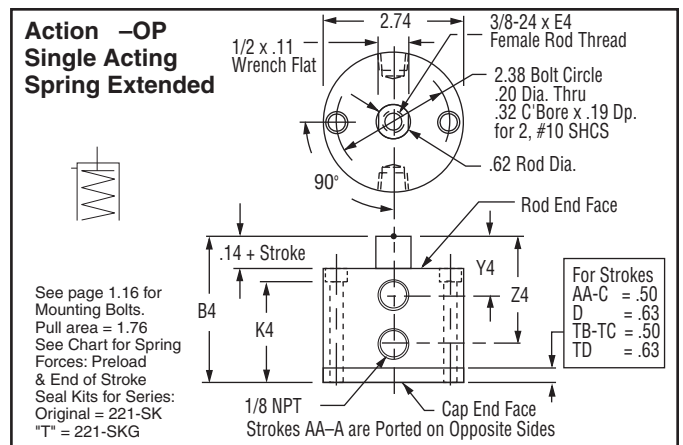
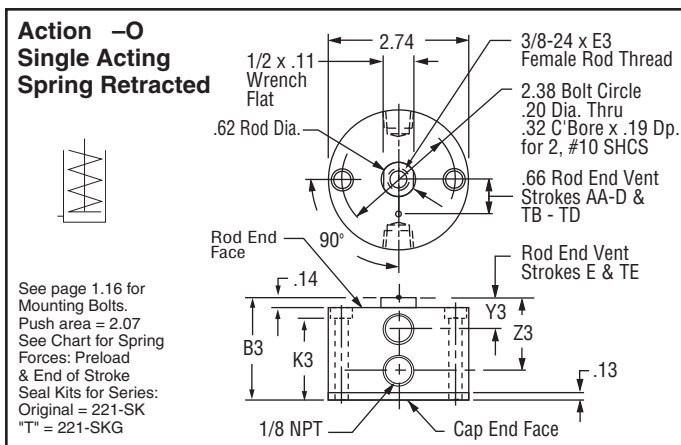

1

Prefix Option -M Metric Cylinder & Rod Thread, 41.3mm Bore
Available on Original and "T" Series with Actions: -X, -XK, -O, -OP
Also see *Option Information* on page 1.7.

Original Series									
Stroke mm	3.2	6.4	12.7	19.1	25.4	38.1	50.8	76.2	101.6
Stroke Letter	AA	A	B	C	D	E	F	G	H

"T" Series							
Stroke mm	6.4	12.7	19.1	31.8	44.5	69.9	95.3
Stroke Letter	TB	TC	TD	TE	TF	TG	TH

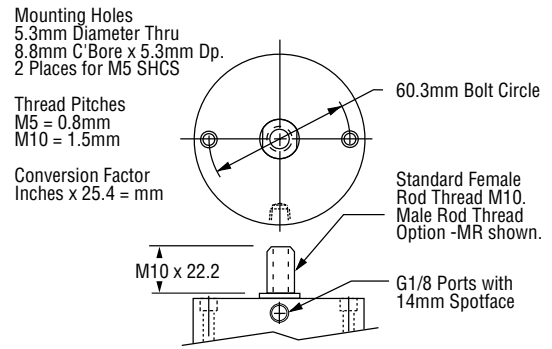

The **Suffix Options** charted on the right are available on Original and "T" Series with the Actions indicated (✓). They require no dimensional changes from the Standard Specifications on page 1.36.
– Also see *Option Information* on pages 1.7 thru 1.15.

	T	V	Q	H	N	C1-C7	LF	LR	LFR	BF	BR	BFR	P14
-X	✓	✓	✓	✓	✓	✓	✓	✓	✓	✓	✓	✓	✓
-XK	NA	✓	✓	✓	NA	✓	NA	✓	NA	✓	✓	✓	✓
-O	NA	✓	✓	✓	✓	NA	NA	✓	NA	NA	✓	NA	✓
-OP	NA	✓	✓	✓	✓	✓	✓	✓	✓	✓	NA	NA	✓

Suffix Options -PM & -SM Clevis Mount
Available on Original and "T" Series
with Actions: -X, -XK, -O, -OP
Also see *Option Information* on page 1.13.

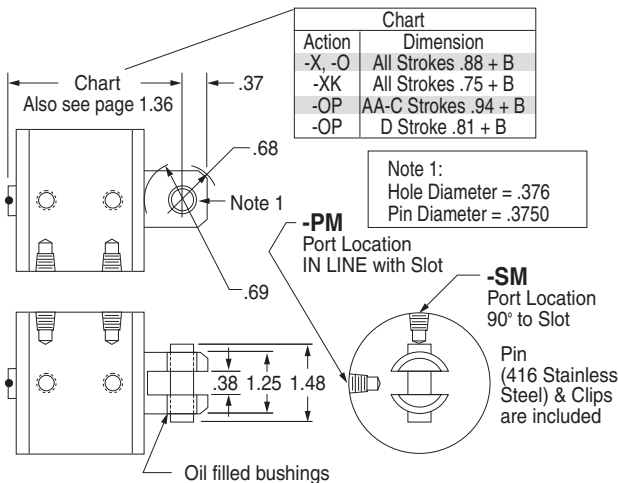

Suffix Options -EPM & -ESM Eye Mount
Available on Original and "T" Series
with Actions: -X, -XK, -O, -OP
Also see *Option Information* on page 1.13.

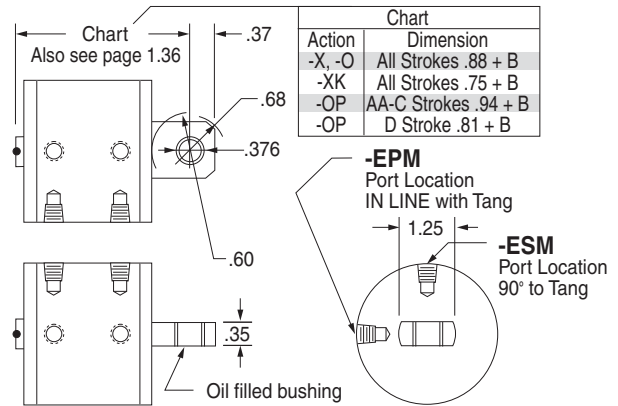

EM-221 Eye Bracket Kit
Mates with Clevis Mount shown above.
Order separately.

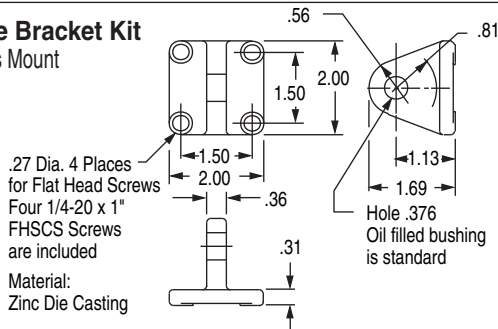

PM-221 Clevis Bracket Kit
Mates with Eye Mount shown above.
Order separately.

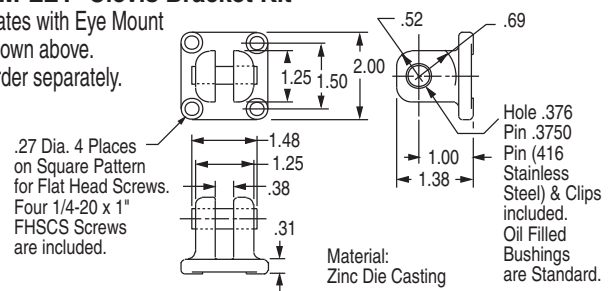

RC-38 Rod Clevis and Pin
Threaded Stud mates with Female Rod thread in **Pancake®** Cylinders. Slot & Pin Mate with EM-121 Eye Bracket shown on the right.

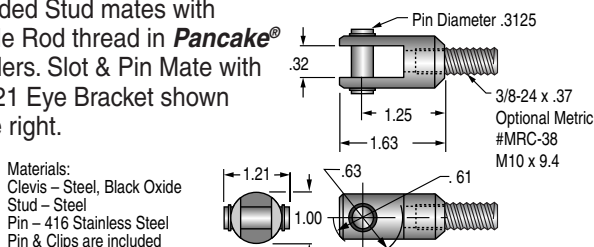

EM-121 Eye Bracket Kit
Mates RC-38 Rod Clevis shown on the left.

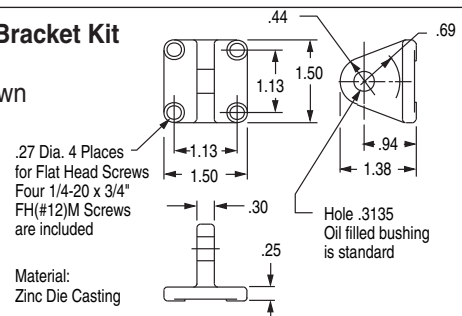

Suffix Options -HHC Hydraulic & -HC Air

Available on Original and "T" Series with Action -X, -O.

Also see *Option Information* on page 1.9 for Pressure and Mounting details.

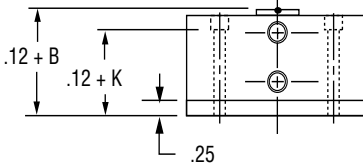

Suffix Option -MR Male Rod Thread

Available on Original and "T" Series with Actions: -X, -XK, -O, -OP. Also see *Option Information* on page 1.8.

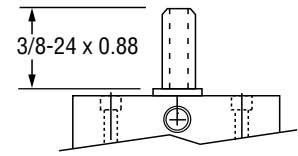

Suffix Option -RS Adjustable Retract Stroke

Available on Original and "T" Series with Actions: -X, -XK, -O, -OP. Also see *Option Information* on page 1.11.

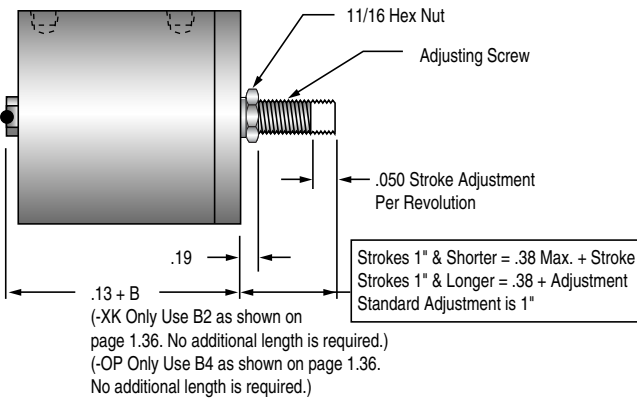

Suffix Option -F Threaded Nose Mount

Available on Original and "T" Series with Actions: -X, -XK, -O, -OP. Also see *Option Information* on page 1.13.

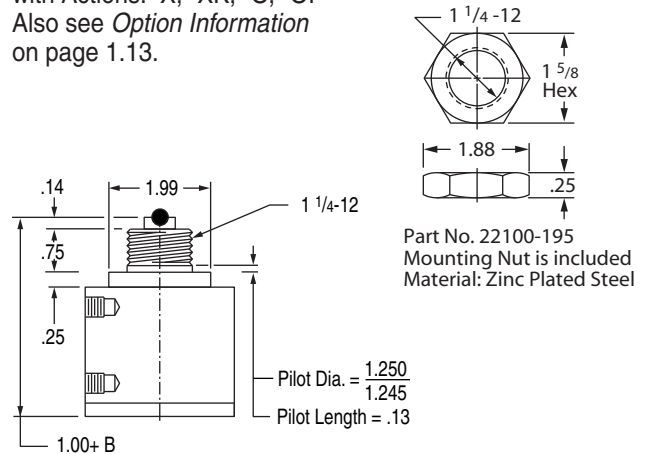

Suffix Option -E Specifies Magnetic Piston and Dovetail Mounting Slot(s)

– Sensors Must be Ordered Separately See Sensor Models Available page 1.14

1 5/8" (221) Bore

Sensors available for "A" & "TB" strokes and longer. Stroke A is ported on opposite sides.

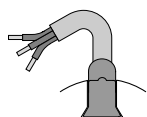

1/4" 60° Dovetail Profile of Sensor & Mounting Slot.

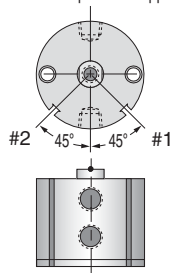

Sensor Slots at Positions #1 and #2

Sensor Slot at Position #1 only

Quick Reference to Standard Strokes

Use the appropriate Stroke Letter in the Model Number

Stroke	Available on Original Series		Available on "T" Series	
	Action X	Action XK	Stroke	Action X, XK
1/4	-----A-----	Not Available	1/4	-----TB
1/2	-----B-----	B	1/2	-----TC
3/4	-----C-----	C	3/4	-----TD
1	-----D-----	D		
1 1/2	-----E-----	E	1 1/4	-----TE
2	-----F-----	F	1 3/4	-----TF
3	-----G-----	G	2 3/4	-----TG
4	-----H-----	H	3 3/4	-----TH

Suffix Option -AS Adjustable Extend Stroke

Available on Original Series with Actions: -X, -XK, -O. Also see *Option Information* on page 1.11.

Stroke Inches	1/8	1/4	1/2	3/4	1	1-1/2	2	3	4
Stroke Letter	AA	A	B	C	D	E	F	G	H
Actions: -X, -XK	BB	1.61	1.74	2.24	2.49	2.80	3.30	3.80	4.80
Actions: -O	BB	1.61	1.74	2.24	2.49	2.80	4.80	NA	NA
	C	1.40	1.66	2.16	2.66	3.16	4.16	5.16	7.16
	D	0.63	0.75	1.00	1.25	1.50	2.00	2.50	3.50
	E	0.63	0.75	1.00	1.25	1.50	2.00	2.50	3.50

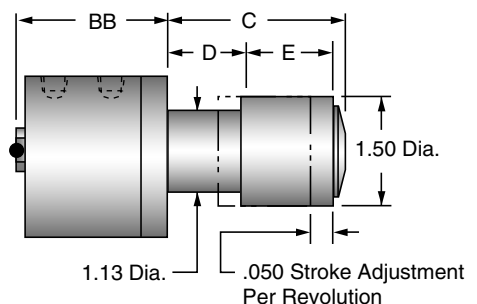

1

Action -XDR Original Series Double Rod, Double Acting

See page 1.16 for
Mounting Bolts
Force Area = 1.76
Seal Kit = 221-SK

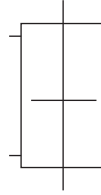

Stroke, Inches	1/8	1/4	1/2	3/4	1	1 1/2	2	3	4
Stroke, Letter	AA	A	B	C	D	E	F	G	H
B	1.61	1.74	2.24	2.49	2.80	3.30	3.80	4.80	5.80
E	.38	.44	.63	.63	.75	.75	.75	.75	.75
K	1.28	1.41	1.91	2.16	2.47	2.97	3.47	4.47	5.47
Y	.64	.64	.52	.52	.52	.52	.52	.52	.52
Z	.64	.64	1.27	1.52	1.83	2.33	2.83	3.83	4.83
Weight, lb.	.97	1.03	1.35	1.46	1.63	1.91	2.19	2.73	3.28

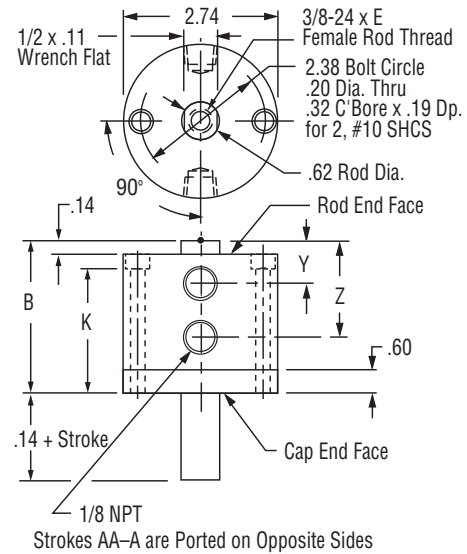

Action -XDRK Original Series Double Rod, Double Acting, Nonrotating

See page 1.16 for
Mounting Bolts
Force Area = 1.70
Seal Kit = 221-SK-K

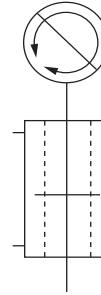

Stroke, Inches	1/8	1/4	1/2	3/4	1	1 1/2	2	3	4
Stroke, Letter	AA	A	B	C	D	E	F	G	H
B	1.61	1.74	2.24	2.49	2.80	3.30	3.80	4.80	5.80
E	.38	.44	.63	.63	.75	.75	.75	.75	.75
K	1.28	1.41	1.91	2.16	2.47	2.97	3.47	4.47	5.47
Y	.64	.64	.52	.52	.52	.52	.52	.52	.52
Z	.64	.64	1.27	1.52	1.83	2.33	2.83	3.83	4.83
Weight, lb.	1.05	1.11	1.44	1.55	1.73	2.01	2.30	2.86	3.42

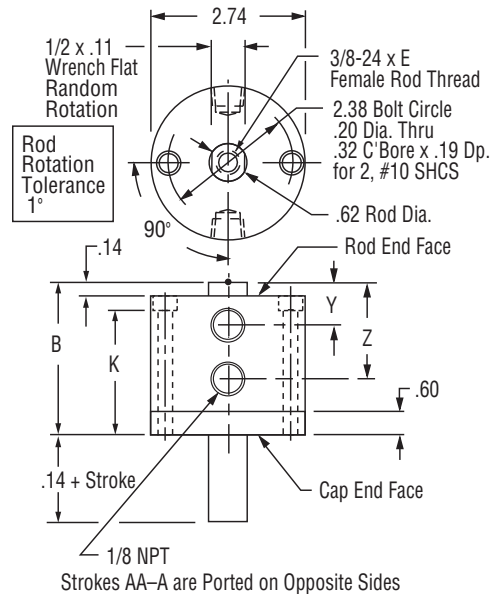

Action -ODR Original Series Double Rod, Single Acting, Spring Retracted

See page 1.16 for
Mounting Bolts
Force Area = 1.76
Seal Kit = 221-SK

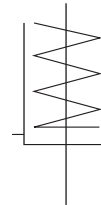

Stroke, Inches	1/8	1/4	1/2	3/4	1	1 1/2
Stroke, Letter	AA	A	B	C	D	E
B	1.61	1.74	2.24	2.49	2.80	4.80
E	.38	.44	.63	.63	.75	.75
K	1.28	1.41	1.91	2.16	2.47	4.47
Y	Rod End Vent Face					.52
Z	.64	.77	1.27	1.52	1.83	3.83
Weight, lb.	.95	1.01	1.30	1.42	1.58	1.86
Spring Return Forces, lb.						
Preload	15.0	8.5	8.5	6.0	4.8	6.0
End of Stroke	20.0	20.0	20.0	18.0	20.0	18.0

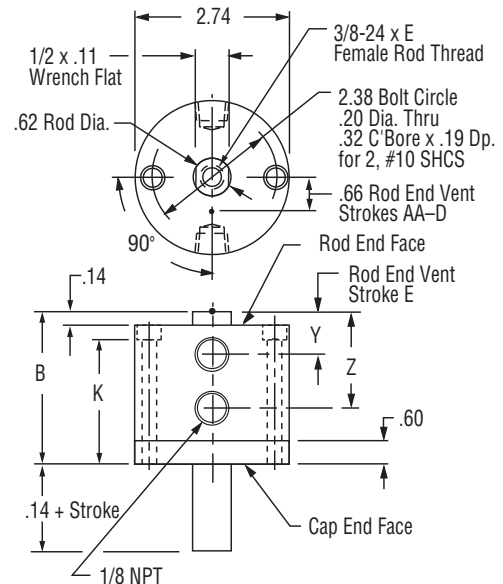

Prefix Option -M Metric Cylinder & Rod Thread, 41.3mm Bore

Available on Original Series with Actions: -XDR, -XDRK, -ODR
Also see *Option Information* on page 1.7.

Mounting Holes
5.3mm Diameter Thru
8.8mm C' Bore x 5.3mm Dp.
2 Places for M5 SHCS

Thread Pitches
M5 = 0.8mm
M10 = 1.5mm

Conversion Factor
Inches x 25.4 = mm

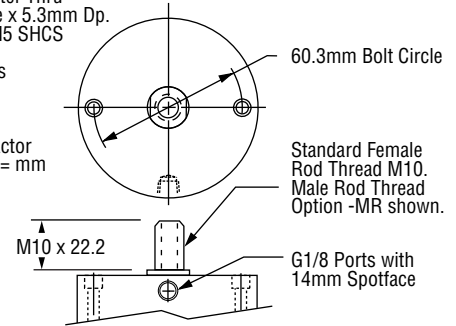

Stroke mm	3.2	6.4	12.7	19.1	25.4	38.1	50.8	76.2	101.6
Stroke Letter	AA	A	B	C	D	E	F	G	H

The **Suffix Options** charted on the right are available on Original Series with the Actions indicated (✓). They require no dimensional changes from the Standard Specifications on page 1.39. – Also see *Option Information* on pages 1.7 thru 1.15.

	T	V	Q	H	N	C1-C7	LF	LR	LFR	BF	BR	BFR	P14	13	25
-XDR	✓	✓	✓	✓	✓	✓	✓	✓	✓	✓	✓	✓	✓	✓	✓
-XDRK	NA	✓	✓	NA	✓	✓	NA	✓	NA	✓	✓	✓	✓	✓	✓
-ODR	NA	✓	✓	✓	✓	NA	NA	✓	NA	NA	✓	NA	✓	✓	✓

Suffix Options -MR, -MR1, -MR2 Male Rod Thread

Available on Original Series with Actions -XDR, -XDRK, -ODR.

- For Rod End only use –MR
- For Cap End only use –MR1
- For Both Ends –MR2

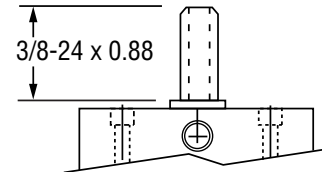

Also see *Option Information* on Page 1.8.

Suffix Options -F, -F1, -F2 Threaded Nose Mount

Available on Original Series with Actions -XDR, -XDRK, -ODR.

- For Rod End only use –F
- For Cap End only use –F1
- For Both Ends use –F2

Also see *Option Information* on page 1.13.

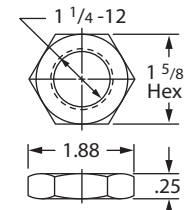
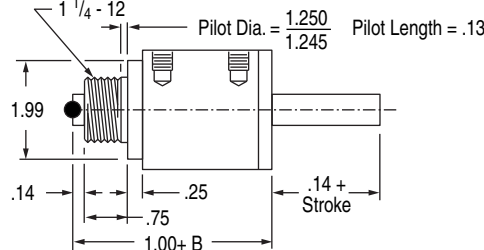

Part No. 22100-195
Mounting Nut is included
Material: Zinc Plated Steel

Suffix Option -E Specifies Magnetic Piston and Dovetail Mounting Slot(s)

Strokes are NOT affected by magnetic piston.

– Sensors Must be Ordered Separately
See *Sensor Models Available* page 1.14

1 5/8" (221) Bore

Sensors available for "A" strokes and longer.
Stroke A is ported on opposite sides.

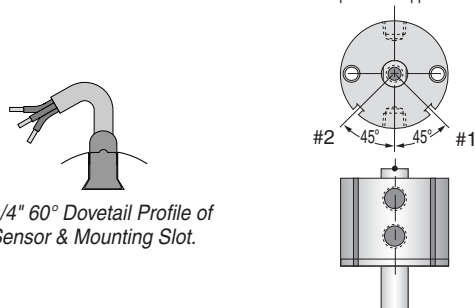

1/4" 60° Dovetail Profile of Sensor & Mounting Slot.

Quick Reference to Standard Strokes
Use the appropriate Stroke Letter in the Model Number

Available on Original Series

Stroke	Action	
	XDR	XDRK
Sensor Slots at Positions #1 and #2	1/4 -----	A ----- Not Available
	1/2 -----	B ----- B
	3/4 -----	C ----- C
	1 -----	D ----- D
Sensor Slot at Position #1 only	1 1/2 -----	E ----- E
	2 -----	F ----- F
	3 -----	G ----- G
	4 -----	H ----- H