

Series XFC

Extreme Force Electromechanical Cylinder



Customer Value Proposition:

The Parker Series XFC Extreme Force Electromechanical Cylinder provides machinery builders a high force electro-mechanical solution offering long life, minimal maintenance, and low operating costs while still maintaining structural rigidity. All this while still providing world class customer service and industry leading delivery times.

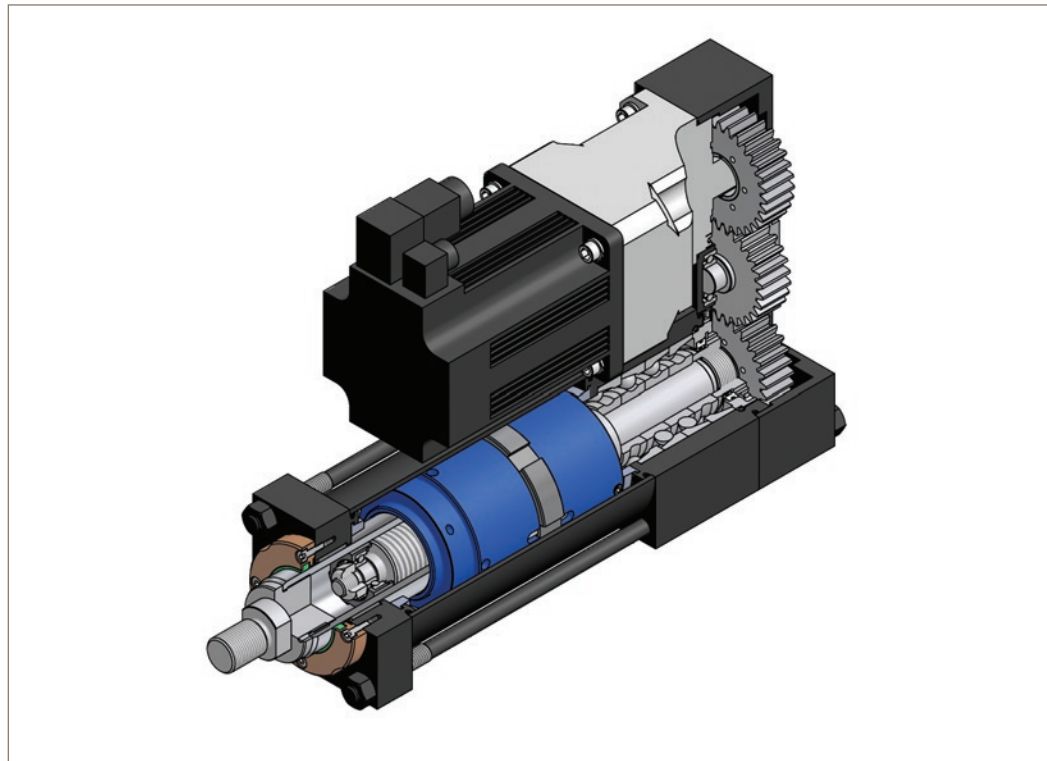

Contact Information:

Parker Hannifin Corporation
US Industrial Cylinder Division
500 S. Wolf Rd.
Des Plaines, IL 60016

phone 847 298 2400
fax 800 892 1008
cylmktg@parker.com

www.parker.com/cylinder

Product Features:

- All Steel Construction
- O-Rings and Elastomeric Seals Throughout
- Standard Metric Hydraulic Tie Rod Construction
- Opposed Preloaded Angular Contact Bearings
- Roller Screw Drive System
- Inline and Parallel Gear Drive Configurations
- Speeds up to 40 Inches per Second
- 178kN Continuous Thrust (40,000 Pounds)
- Parker Bayside Stealth Gearhead Direct Mount
- Parker MPP Max Plus Motors Standard
- Strokes from 50mm to 2000mm in 1mm increments



ENGINEERING YOUR SUCCESS.

Parker Series XFC

Parker is pleased to introduce a new level of Electric High Thrust cylinders featuring roller screw drive technology – Series XFC. The Series XFC Extreme Force Electromechanical Cylinder is designed to provide heavy machine builders a high force electro-mechanical solution offering long life, minimal maintenance and low operating costs while maintaining structural rigidity. All this while still providing world class customer service and industry leading delivery times.

As a worldwide leader in fluid power cylinder products, Parker has combined the best of both worlds into one unique product. All of the benefits of electro-mechanical control and cleanliness combined with the structural rigidity and durability of a traditional hydraulic tie-rod cylinder.

Flexibility & Programmability: In applications where high loads and/or high speed motion are required, roller screws offer a very attractive solution. Servo Motors and controls feature simplified programming with auto-tuning capabilities reducing installation start up time and expenses.

Electro-mechanical control systems utilizing servo motor technology provide infinite programmability along with

Frame Size	XFC075	XFC090	XFC115	XFC140	XFC165	XFC190
Continuous Thrust kN (lbs)	20 (4500)	34 (7,500)	54 (12,000)	80 (17,500)	120 (26,500)	178 (40,000)
Maximum Thrust kN (lbs)	40 (9,000)	68 (15,000)	108 (24,000)	160 (35,000)	240 (53,000)	356 (80,000)
Maximum Speed mm/sec (in/sec)	1,000 (40)	1,000 (40)	1,000 (40)	1,000 (40)	1,000 (40)	1,000 (40)
Maximum Acceleration mm/sec² (in/sec²)	2000 (80)	2000 (80)	2000 (80)	2000 (80)	2000 (80)	2000 (80)
Maximum Stroke mm (in)	2,000 (78.75)	2,000 (78.75)	2,000 (78.75)	2,000 (78.75)	2,000 (78.75)	2,000 (78.75)

some advantages not easily obtainable with other solutions such as multiple move profiles, adjustable acceleration and deceleration, force control, and absolute positioning capabilities. These features allow the system to be easily adaptable to changing application conditions and performance requirements with minimal modification.

Maintenance & Installation: Roller screw cylinder systems require little or no maintenance when compared to their fluid power alternatives while still delivering long life and high performance. Due to the small number of components required for a complete system the commissioning time required for operation is significantly reduced. This allows system builders to quickly install, troubleshoot, and test system capabilities faster and more reliably than other alternatives.

Environmental Considerations:

With electro-mechanical system technology, fluid leaks, filter changes, and air bleeding are a thing of the past. Simply mount the cylinder, plug in the cables, download a program and you are up and running in record time.

Anti-Rotation:

Due to the steel round body cylinder design, internal anti-rotation of the thrust tube is not available in Series XFC Cylinders. Applications must be designed to prevent thrust tube rotation during operation.

Parker's Capabilities:

With Hydraulic, Pneumatic, and now Electro-mechanical technologies Parker can provide the best solution for a specific application regardless of requirements with an unmatched offering of cylinder products to more than 100 industrial markets worldwide.

