

Inline Bronze Filters



137



137A

Features

- All Bronze Unit
- Designed for Applications where Fine Straining of Air is Required
- Porous Bronze Element Strains Out Particles Larger than 90 Microns (.0035 Inch)

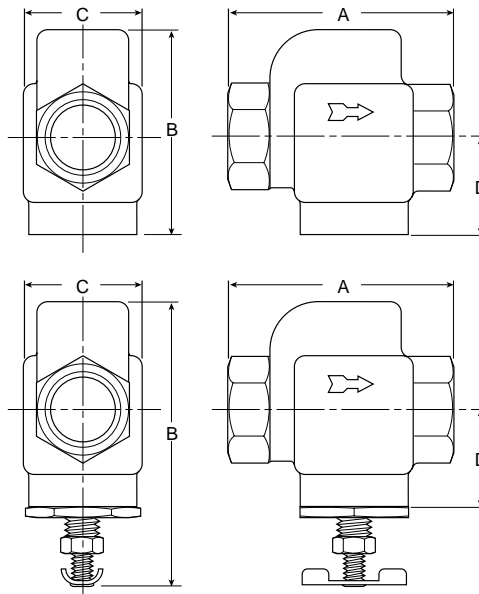

Port Size	90 Micron Element*	
	No Drain	With Manual Petcock Drain
1/4"	137-02	137-02A
3/8"	137-03	137-03A
1/2"	137-04	137-04A

* Add "V" Suffix for 5 Micron Element.

In-Line Bronze Filters			
A	B	C	D
With No Drain			
2.63 (66.7)	2.38 (60)	1.41 (35.7)	1.16 (29.4)
With Manual Twist Drain			
2.63 (66.7)	3.19 (81)	1.84 (46.8)	1.16 (29.4)

inches (mm)

Replacement Elements

5 Micron.....	137AY77-5
20 Micron.....	137AY77-20
90 Micron.....	RK137Y

Specifications

Maximum Pressure300 PSIG

Performance –

Pressure Drop (PSIG) at Various Conditions

Flow	5	10	15	20	25
Supply Pressure 100 PSIG	.05	.15	.06	1.20	1.70
Supply Pressure 150 PSIG	.02	.10	.30	.70	1.00

Weight –

1/4" & 3/8".....	.9 lb. (0.41 kg) / Unit
	44 lb. (19.96 kg) / 48-Unit Master Pack
1/2".....	1.1 lb. (0.49 kg) / Unit
	54 lb. (24.49 kg) / 48-Unit Master Pack

Materials of Construction

Body.....	Bronze
Element –	
Standard.....	90 Micron Porous Bronze
Optional.....	5 Micron Porous Bronze
Seals.....	Buna N