

GO SILENTLY  
AT HIGH PRESSURE  
& HIGH SPEED

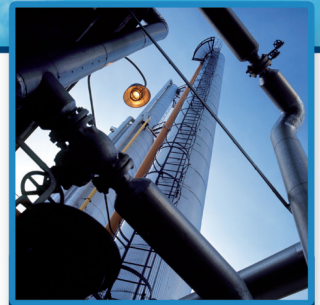

Patents approved  
Brevetti approvati



INDUSTRIAL



MOBILE



MARINE

# CONTINUUM<sup>®</sup> PUMP series

Helical rotors pumps for high pressure  
and no noise application

The new generation of gear pumps for  
NO PULSATION & NO NOISE

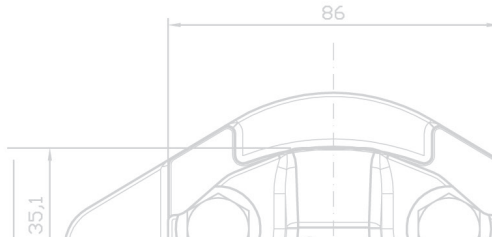
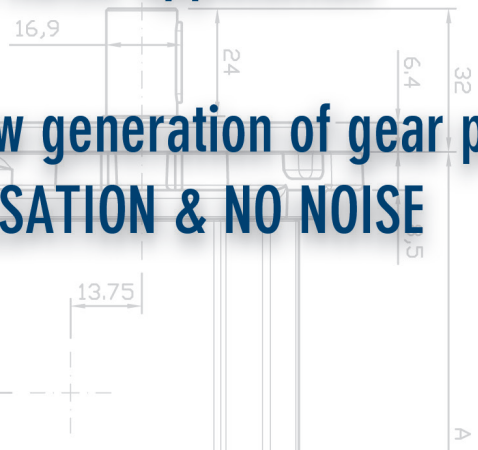
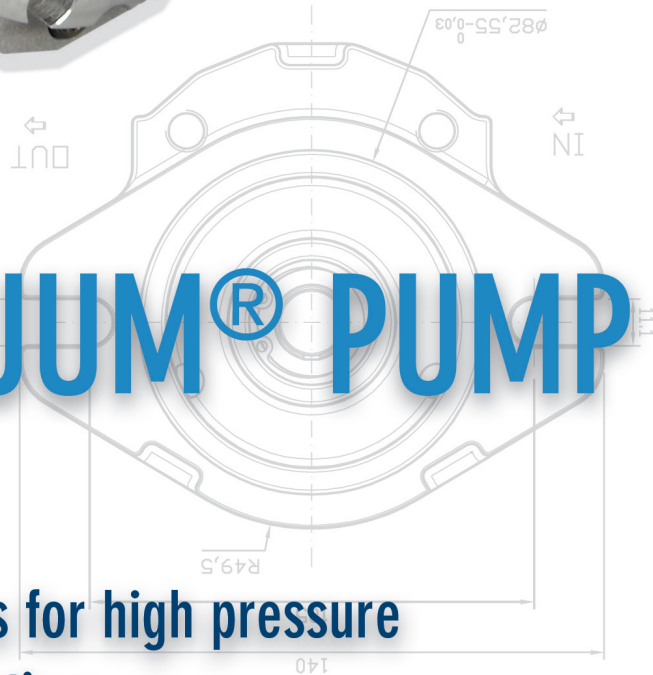

## Continuum® pump

**Achieves better efficiency, lower production cost, better life quality for the industrial world.**  
**Ottiene alti livelli di efficienza, ridotti costi di produzione ed una migliore qualità del lavoro.**

Reducing noise in the workplace has become a necessity for many companies. By now most companies have recognized noise as a cost weighting on the economics of their businesses. Noise pollution remains a serious problem to be solved for both stationary and mobile machinery. Hydraulic pumps, above all those for high pressure, entail unacceptable noise and/or vibration levels in many different applications.

Up to now the noise problem has always been approached in the only possible way: with secondary and expensive activities such as using pulsation dampers, hoses, damping rails and rings, encapsulating the hydraulic components or the entire system and so on.

SETTIMA decided to start to design a new gear pumps generation capable to reduce as much as possible the acoustic emissions and the consequent vibration level. Some years ago the result was the **Continuum® pump series**, able to reduce down to 52 dB(A) the normal operation noise.

Today SETTIMA presents the new generation of **Continuum® pumps**, silent as always, but much more efficient and with longer lifetime even at heavy duty, at all pressure and speed ranges.

The most important economic benefits of using **Continuum® pumps** are:

- very low pump pulsations reduce dramatically also vibrations with no dispersion of energy,
- saving money respect to the more expensive traditional pumps such as piston pumps and internal gear pumps,
- high volumetric efficiency, also at very low speed, contributes to cost reduction and also enables the pump to be driven by motor at a variable velocity with consequent energy saving,
- cost saving by eliminating second noise reduction measures,
- keeping the same external dimensions of gear pump, with no necessity to redesign the system in case of replacement.

### COMPETITIVE ANALYSIS

**Continuum® pump** is a valid alternative to silently replace different traditional solutions of noisy high pressure pump.

**Continuum® pump** can replace the following types of high pressure pump:

- External gear pumps
- Internal gear pumps
- Fixed displacement vane pumps
- Fixed displacement piston pumps

Please contact Settima for all information about any possible replacement.

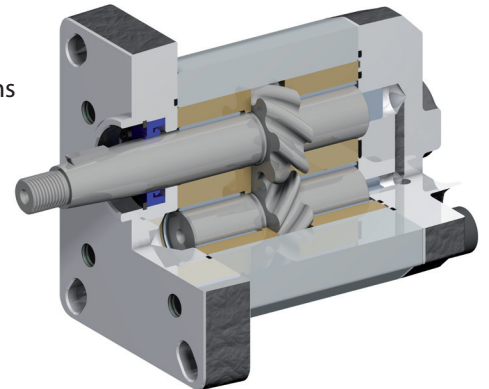

### ORIGIN OF NOISE AND VIBRATIONS KNOCKED DOWN BY CONTINUUM® PUMP

#### LA POMPA CONTINUUM® HA ELIMINATO LE ORIGINI DEL RUMORE E DELLE VIBRAZIONI

The typical sound emissions of gear pumps have two distinct origins: mechanical noise and hydraulic noise. The mechanical noise is what can be expected from any pair of gears. The hydraulic noise, however, is generated by the perturbations of fluid pressure through the pump. This noise and/or vibration comes from three basic components:

- cavitation, that can cause serious noise in addition to structural damage to mechanical components
- the peak pressure that arises from trapping of fluid between the top and the bottom of the tooth,
- the "ripple" or the flow pulsation during meshing that causes pressure pulsation.

The continuous contact helical rotor **Continuum® pump** has solved these problems with sophisticated and efficient systems.

### THINK DIFFERENT: THE SILENT AND UNIQUE REVOLUTION OF CONTINUUM® PUMP

#### UNA RIVOLUZIONE SILENZIOSA: LA POMPA CONTINUUM®

As for classic gear pumps, the transport flow is perpendicular to the axes, but the rotors profile, specially developed and internationally patented, does not trap any volume since the helical design of the profile plays the role of completing an overlap, making a gentle transmission of fluid resulting in a dramatic reduction of pulsation. There is just a single point of contact between the profiles

during rotation, which eliminates the pockets acting on the axial thrust washer and the noise associated with this problem.

**The Continuum®** core and its technological innovation is based on three patented breakthroughs:

- The rotor profile
- The screw step
- The inner force balancing.



**MANUFACTURING ACCURACY IN ANY DETAILS**  
**MASSIMA ACCURATEZZA NEI DETTAGLI**

**SETTIMA** produces hydraulic pumps since over thirty years, achieving a high level of competence and accuracy in the manufacture of high-precision pump drives. Together with top production machineries, efficient test environments, 3D drawing capability and special materials for rotors and bushings, **SETTIMA** constantly achieves products of high quality that is the industry standard.

**CONTINUUM® PUMP ADVANTAGES**  
**VANTAGGI DELLA POMPA CONTINUUM®**

- Low noise also at high speed (up to 6.500 RPM).
- Average of 15 db(A) less noisy than standard external gear pumps.
- Reduced noise level for the machine operator and surroundings.
- Cost saving by eliminating second noise reduction measures.
- Easy to replace thanks to compatibility with all external gear pumps.
- Helps meet legal noise requirements.
- Continuous variable flow rate (0% to 100%).
- Undirectional pump and/or bi-directional pump/motor.
- Intermittent operation at high pressure & low speed.
- Allowed to be driven by servo motors or asynchronous motors.
- High volumetrical efficiency.
- Fast reverse RPM allowed: CCW max < 400.
- Response time < 100 ms due to very small internal mechanical inertia.



Environment: 100bar - 40 cSt - 1.500 rpm

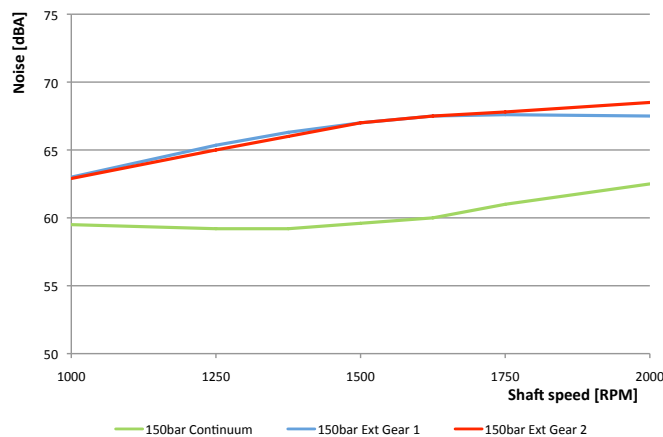
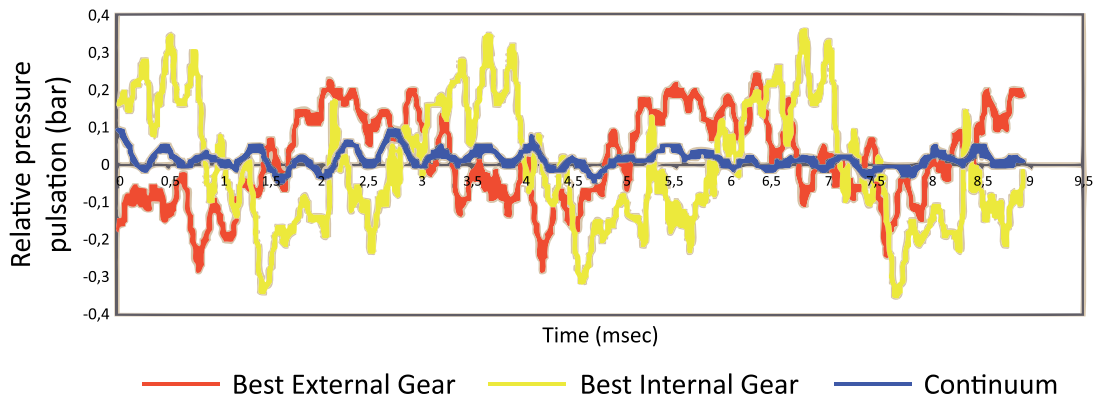

## Applications / Applicazioni

### INDUSTRIAL

Machine tools lubrication systems.

Lifting equipment, hydraulic systems for dock-levelers.

Hydraulic transmission systems.

Machines lubrication.

Chemical metering.

Hydraulic systems for injection moulding machines, presses, compactors and balers.

Systems for lubrication and cooling of gearboxes and bearings.

Hydraulic powerpack.

Hydro power.

Feeder system for filter circuits, cooling circuits, lubrication applications, pump transfer unit.

### MOBILE

Ground-handling equipment.

Agricultural machinery.

Hydraulic systems for parking systems.

Steering units.

Torque converters & power-shift transmissions.

Street-sweeping vehicles.

Shredder systems.

Waste container level lifter.

### ENVIRONMENTAL INDUSTRY

Baler and compacting of waste.

Containers.

Hooklift containers.

Back loading containers.

Front loading containers.

Liftdumper containers.

Hooklift systems.

Garbage trucks.

Mobile compactors.

Stationary compactors.

### MARINE

Marine power hydraulics.

Rudder actuators (tandem system).

Propeller pitch control.

Propeller drive (power transmission from engine).

Rotary vane steering gears.

Minipowerpacks (dock operation, door control).

Yacht building industry (lifting systems: fly bridge cranes, tenderlift, elevator, walkways, automatic swimming ladders, side boarding ladders, pitch controls and operations, hydraulic davits).



## Technical characteristics / Caratteristiche tecniche

**SPECIAL HELICAL ROTORS – CONTINUUM®** represents an innovative and revolutionary gear pump. The patented profile of the **Continuum®** rotors permits just a single point of contact between gears: this results, together with a particular screw step and inner force balancing, in the total absence of trapped and compressed oil, and leads to no noise and no pulsation.

**HIGH PRESSURE – CONTINUUM®** has been designed for high pressure, high speed and heavy duty.

**TANDEM GROUP – CONTINUUM®** can be also assembled as a double pump, connecting two pumps from different groups: from group 1 to group 4.

Technical characteristics

<b>Models</b> <b>Modelli</b>	28 - 33 - 38 - 47 - 55 - 72 - 92* - 106*			
<b>Flanges</b> <b>Flange</b>	Group 1 – Group 2 (European, German, BKT, SAE-A) – Group 3 (European, SAE-B) – Group 4 (SAE-D) <i>Gruppo 1 – Gruppo 2 (Europeo, Tedesco, BKT, SAE-A) – Gruppo 3 (Europeo, SAE-B) – Gruppo 4 (SAE-D)</i>			
<b>Connections</b> <b>Conessioni</b>	BSPP (GAS) – SAE 3000/6000 PSI – FL 4 HOLES M6 SU Ø40 DN20 (mentioned connections depend on model) <i>BSPP (GAS) – SAE 3000/6000 PSI – FL 4 HOLES M6 SU Ø40 DN20 (in base al modello)</i>			
<b>Installation position</b> <b>Posizione di installazione</b>	External and/or under oil <i>Esterna e/o immersa</i>			
<b>Shaft rotation</b> <b>Rotazione</b>	Clockwise (please contact Settima for counter clockwise) <i>Destra (contattare Settima per sinistra)</i>			
<b>Shaft speed</b> <b>Velocità di rotazione</b>	From 150 to 6.500 rpm (for usage below 1.000 rpm or over 1.800 rpm please contact Settima) <i>Da 150 a 6.500 rpm (per utilizzi a giri inferiori a 1.000 rpm o superiori a 1.800 rpm contattare Settima)</i>			
<b>Flows</b> <b>Portate</b>	From 4 up to 220 cm <sup>3</sup> – from 6L/min up to 330L/min (at 1.500 rpm) <i>Da 4 fino a 220 cm<sup>3</sup> – da 6L/min fino a 330L/min (a 1.500 rpm)</i>			
<b>Operating pressure</b> <b>Pressione operativa</b>	Max. Continuous: 275 bar	Depending on models	Max. Continuo: 275 bar	<i>In base al modello</i>
	Max. Cycle ON/OFF: 280 bar	Depending on models	Max. Ciclo ON/OFF: 280 bar	<i>In base al modello</i>
	Max. Peak: 300 bar	Depending on models	Max. Picco: 300 bar	<i>In base al modello</i>
<b>Inlet pressure</b> <b>Pressione di aspirazione</b>	0.8 – 3 bar (depends on models) 0,8 – 3 bar (in base al modello)			
<b>Fluids</b> <b>Fluidi</b>	- Mineral oil - Synthetic oil		- Olio minerale - Olio sintetico	
<b>Viscosity</b> <b>Viscosità</b>	Possible: from 5 up to 800 cSt** Recommended: from 32 up to 150 cSt Starting condition: up to 3.000 cSt**		<i>Consentita: da 5 fino a 800 cSt** Raccomandata: da 32 fino a 150 cSt Condizioni di avviamento: fino a 3.000 cSt**</i>	
<b>Environmental temperature</b> <b>Temperatura ambiente</b>	From -15°C up to +60°C <i>Da -15°C a +60°C</i>			
<b>Oil temperature</b> <b>Temperature olio</b>	From -15°C up to +80°C*** <i>Da -15°C a +80°C***</i>			
<b>Contamination level</b> <b>Livello di contaminazione</b>	Up to 8 NAS (18/17/14 ISO4406) (for heavy duty operations over 150 bar, over 4 working hours/day, 100 cycle/day oil ISO 46) <i>Fino a 8 NAS (18/17/14 ISO4406) (per lavoro ad alto sforzo oltre 150 bar, oltre 4 ore lavorative/giorno, 100 cicli/giorno olio ISO 46)</i>			
<b>Filtration</b> <b>Filtrazione</b>	From 25 to 10 µm (for heavy duty operations over 150 bar, over 4 working hours/day, 100 cycle/day oil ISO 46) <i>Da 25 a 10 µm (per lavoro ad alto sforzo oltre 150 bar, oltre 4 ore lavorative/giorno, 100 cicli/giorno olio ISO 46)</i>			
<b>Seals</b> <b>Guarnizioni</b>	NBR, FKM (others on request) <i>NBR, FKM (altri a richiesta)</i>			
<b>Acoustic emissions</b> <b>Emissioni acustiche</b>	From 52 up to 63 db(A) at 2.950 rpm <i>Da 52 fino a 63 db(A) at 2.950 rpm</i>			
<b>Flanges material</b> <b>Materiale delle flange</b>	Cast iron <i>Ghisa</i>			
<b>Pump body</b> <b>Corpo</b>	Extruded aluminium alloy <i>Alluminio estruso</i>			

\* Model GR92 and GR106 will be available soon. I modelli GR92 e GR106 saranno disponibili a breve.

\*\* Please for more information about possible and starting conditions of viscosity contact Settima. Contattare Settima per maggiori informazioni sui livelli di viscosità possibili e quelli delle condizioni di inizio lavoro.

\*\*\* For higher temperature than 50°C, please, contact Settima. Per temperature superiori a 50°C, contattare Settima.

Product description / Descrizione prodotto

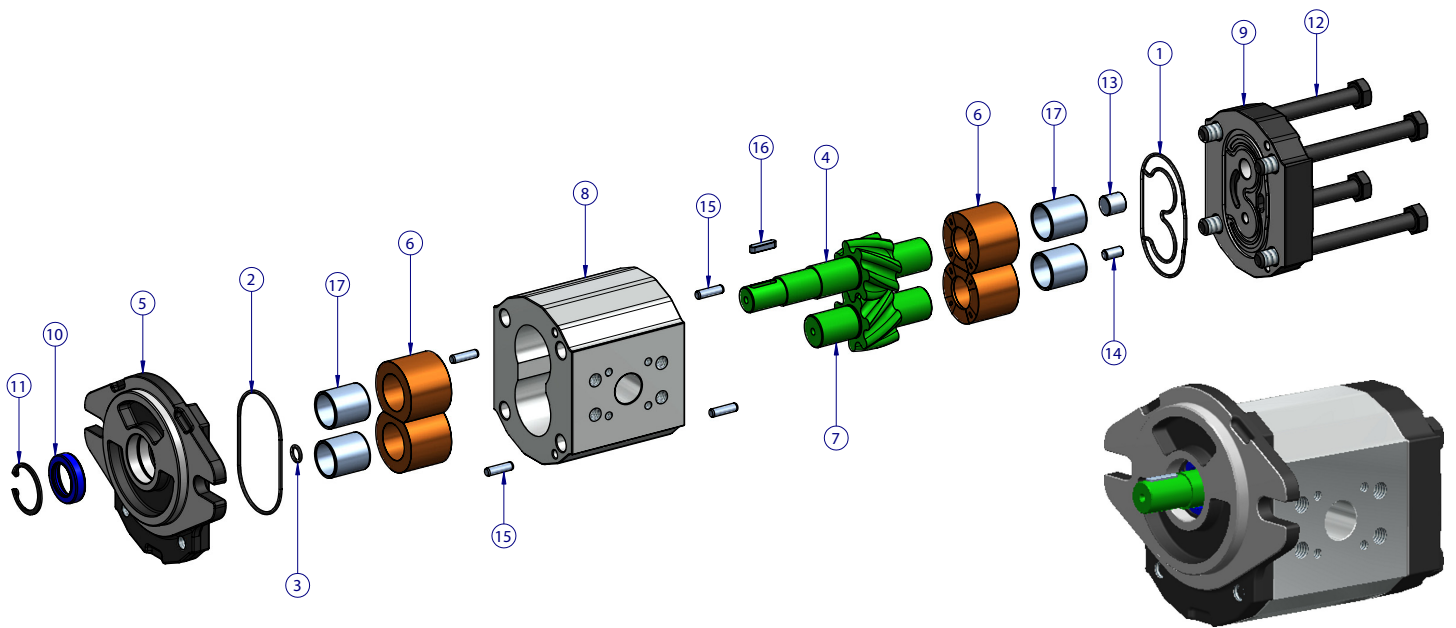

N°	DESCRIPTION/DESCRIZIONE	MATERIAL / MATERIALE
1	O-ring seal / O-ring	NBR
2	O-ring seal / O-ring	NBR
3	O-ring seal / O-ring	NBR
4	Driving Continuum® rotor / Rotore guida Continuum®	Hardened steel / Acciaio temprato
5	Motor flange / Flangia motore	Cast iron / Ghisa
6	Ring for bush / Anello porta boccia	Bronze / Bronzo
7	Driven Continuum® rotor / Rotore guidato Continuum®	Hardened steel / Acciaio temprato
8	Body / Corpo	Extruded aluminum alloy / Alluminio estruso
9	Cover flange / Flangia	Cast iron / Ghisa
10	Seal / Anello di tenuta	NBR
11	Seeger / Seeger	Steel / Acciaio
12	Screws / Viti di fissaggio	Steel / Acciaio
13	Piston / Pistone	Steel / Acciaio
14	Piston / Pistone	Steel / Acciaio
15	Centring Keys / Spine di centraggio	Steel / Acciaio
17	Bushings / Bronzine	Steel with PTFE coating / Acciaio con rivestimento PTFE

Standard type and options

	STANDARD	OPTIONS
Pump Body	Alluminium	Cast iron
Seal kit	NBR	FKM

## Ordering code / Codice ordine

### Single pump / Pompa singola

Type <i>Tipo</i>	Class <i>Classe</i>	Displacement <i>Cilindrata</i>	Flange & shaft <i>Flangia &amp; albero</i>	Ports <i>Porte</i>	Shaft seal <i>Guarnizione albero</i>	Rotation <i>Rotazione</i>
GR28	2V	004-006-008-010-013	F1AC3-F1PAC2-F1KAG54-F1LAGL54-FSAEAAAC-F1KAGL54	G-U	Standard NBR <b>(none)</b>	Standard DX <b>(none)</b>
GR33	2V	010-013-015-018	F2AC4-F2BK7AG-FSAEAAAC-FSAEAAT9	G-Q-M-U		
GR38	2V	016-018-020-022-025-028	F2AC4-F2BK7AG-FSAEAAAC-FSAEAAT11-FSAEAAT9	G-Q-M-U		
GR47	2V	028-032-036-040-045-050	F3AC9-FSAEBAC-FSAEBAT13	O-U	Optional FKM <b>V</b>	Optional
GR55	2V	050-063-075-090	FSAEBAC-FSAEBAT15	O-OE		
GR72	2V	094-101-125-150-175-200-220	FSAEDAC-FSAEDAT23	ME		<b>SX*</b>

\* Please Contact Settima for SX counter clockwise optional rotation.  
 Contattare Settima per rotazione SX opzionale.

### DIRECTION OF ROTATION / SENSO DI ROTAZIONE

**Continuum**® pumps are available with right rotation as standard configuration and left rotation as optional configuration. Right hand rotation means that, when standing in front of the pump, with driving shaft towards to the observer, the pump is rotating clockwise (DX). The other way around with left hand rotation, counter clockwise (SX).

Le pompe **Continuum**® sono fornite con la configurazione standard di rotazione destra. Opzionale la rotazione sinistra. Con rotazione destra (DX) si intende che, guardando la pompa frontalmente, con l'albero conduttore sporgente verso il punto di osservazione, la rotazione sarà in senso orario, con il lato mandata sulla destra e il lato aspirazione sulla sinistra della pompa. Viceversa per quanto riguarda la rotazione sinistra (SX).

**Continuum**® pumps, despite the type of configuration, can rotate to the opposite side if the pressure is not higher than 10% of maximum continuous pressure (check the Technical Characteristics table).

Le pompe **Continuum**®, qualunque configurazione di rotazione abbiano, possono ruotare in senso inverso a pressioni non superiore al 10% della massima pressione continua (verificare nella tabella delle caratteristiche tecniche).

DX: Clockwise rotation / Rotazione destra

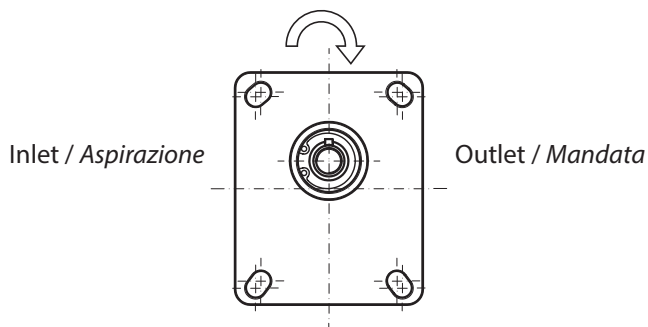

SX: Counter clockwise rotation / Rotazione sinistra

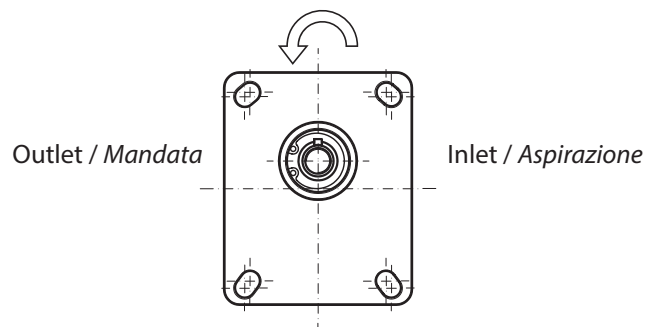

## GR28 - Dimensional drawings / Disegni dimensionali

### GR28 SHAFT AND FLANGE TYPE AND DIMENSIONS / TIPO ALBERO E FLANGE E DIMENSIONI

#### Group 1 pumps / Pompe gruppo 1

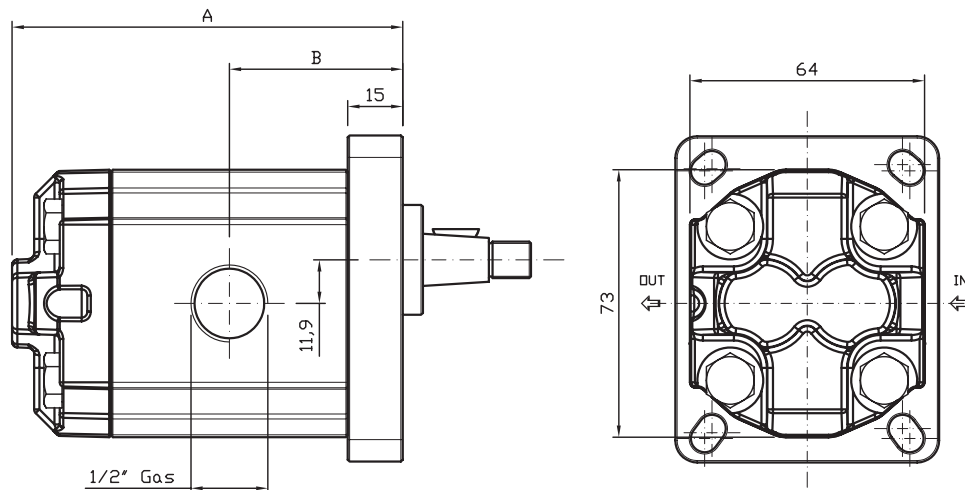

#### Available flanges and shafts / Flange ed alberi disponibili

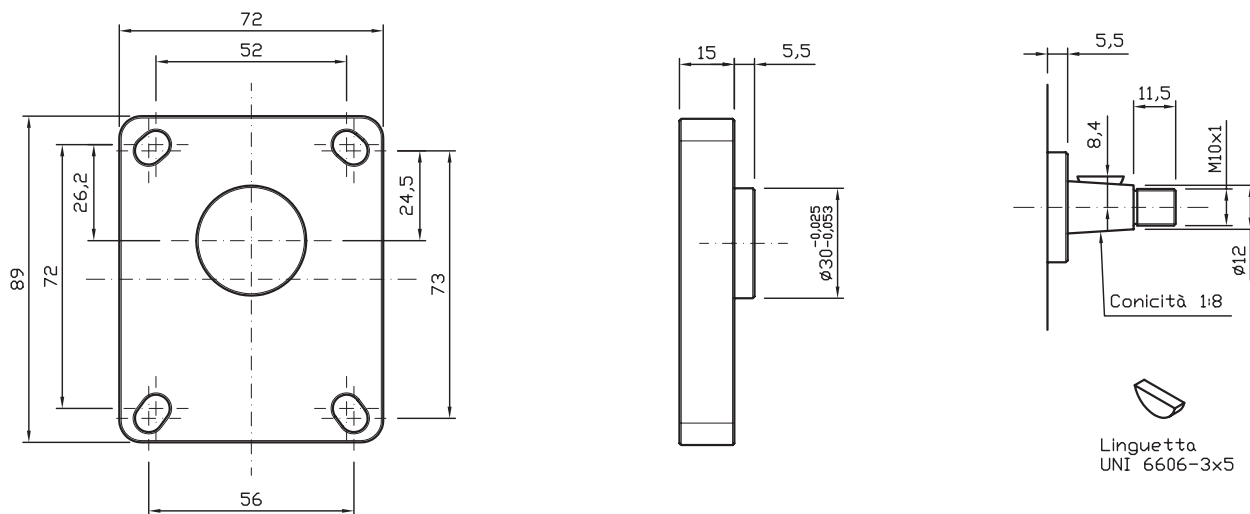

GR28 - TYPE / TIPO 1-C3

Type Tipo	CC	L/min	Dimensions A Dimensioni A	Dimensions B Dimensioni B	Continuous Pressure Pressione continua	Intermittent Pressure Pressione intermittente (*)	Peak pressure Picco pressione (*)	Noise level Livello rumore
4	4,2	6,0	101,0	44,50	275	280	300	55
6	6,4	9,2	106,5	47,25	275	280	300	55
8	8,3	12,0	111,5	49,75	246	260	280	55
10	10,2	14,7	116,5	52,25	222	250	270	55
13	12,9	18,6	123,4	55,55	176	230	250	55

Max torque / Coppia max: 100 Nm

\* Intermittent: cycle 20 sec. ON & 3 sec. OFF - Peak: cycle 1 sec. ON & 3 sec OFF. Intermittente: ciclo 20 sec. ON & 3 sec. OFF - Picco: ciclo 1 sec. ON & 3 sec OFF



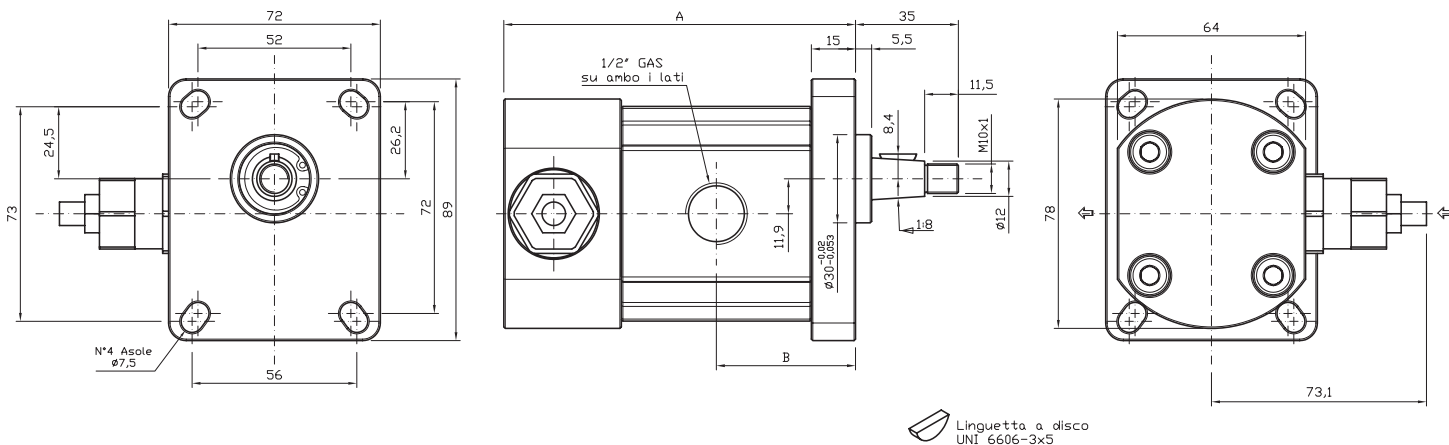

GR28 - TYPE / TIPO 1-C3 (with safety valve/con valvola di massima)								
Type Tipo	CC	L/min	Dimensions A Dimensioni A	Dimensions B Dimensioni B	Continuous Pressure Pressione continua	Intermittent Pressure Pressione intermittente (*)	Peak pressure Picco pressione (*)	Noise level Livello rumore
4	4,2	6,0	114,1	44,50	275	280	300	55
6	6,4	9,2	119,5	47,25	275	280	300	55
8	8,3	12,0	124,5	49,75	246	260	280	55
10	10,2	14,7	129,5	52,25	222	250	270	55
13	12,9	18,6	136,4	55,70	176	230	250	55

Max torque / Coppia max: 100 Nm

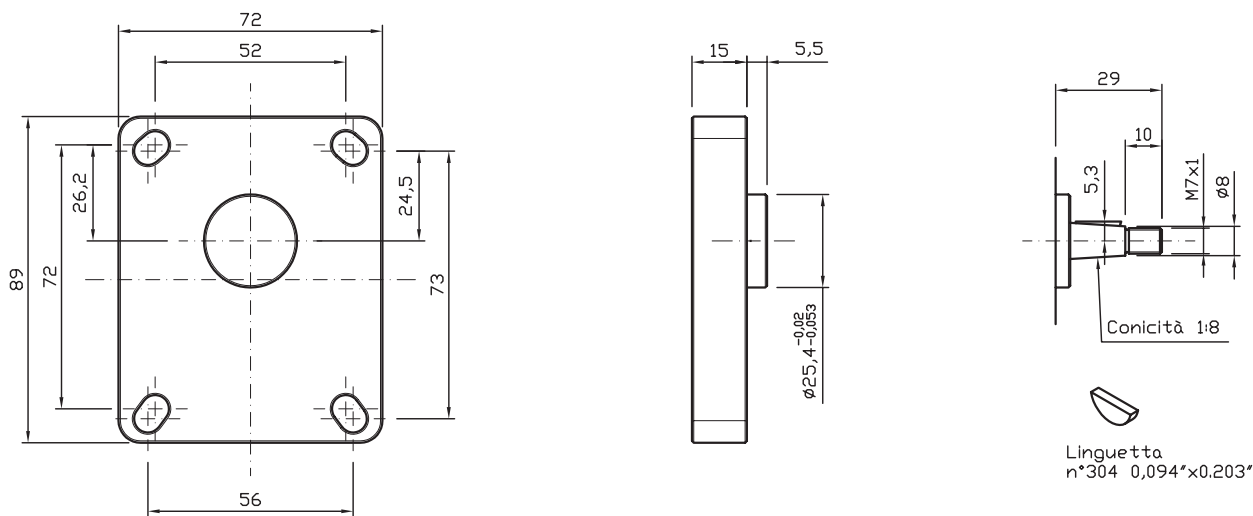

GR28 - TYPE / TIPO 1P-C2								
Type Tipo	CC	L/min	Dimensions A Dimensioni A	Dimensions B Dimensioni B	Continuous Pressure Pressione continua	Intermittent Pressure Pressione intermittente (*)	Peak pressure Picco pressione (*)	Noise level Livello rumore
4	4,2	6,0	101,0	44,50	240	260	280	55
6	6,4	9,2	106,5	47,25	230	240	270	55
8	8,3	12,0	111,5	49,75	200	210	220	55
10	10,2	14,7	116,5	52,25	160	170	180	55
13	12,9	18,6	123,4	55,70	140	150	160	55

Max torque / Coppia max: 50 Nm

\* Intermittent: cycle 20 sec. ON & 3 sec. OFF - Peak: cycle 1 sec. ON & 3 sec OFF. Intermittente: ciclo 20 sec. ON & 3 sec. OFF - Picco: ciclo 1 sec. ON & 3 sec OFF

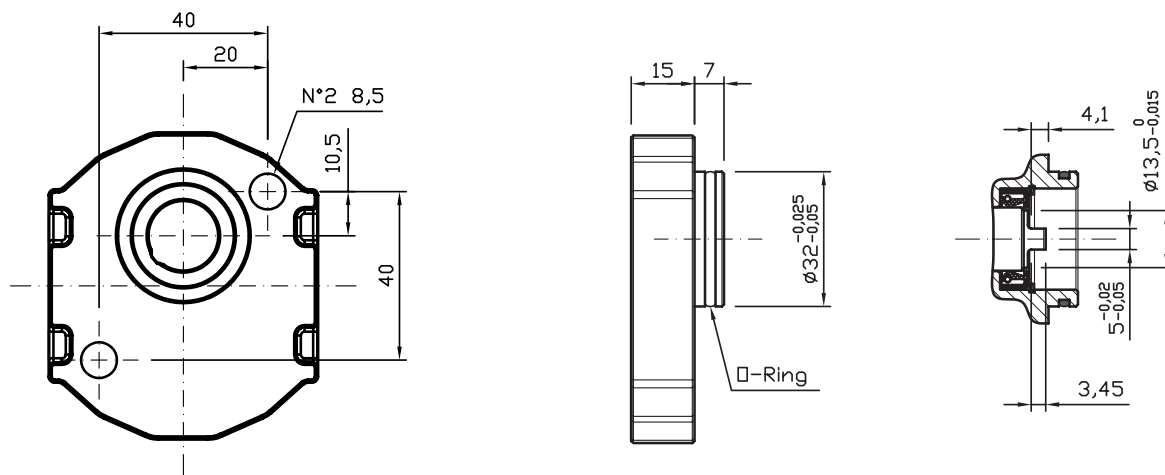

GR28 - TYPE / TIPO 1K-G54								
Type Tipo	CC	L/min	Dimensions A Dimensioni A	Dimensions B Dimensioni B	Continuous Pressure Pressione continua	Intermittent Pressure Pressione intermittente (*)	Peak pressure Picco pressione (*)	Noise level Livello rumore
4	4,2	6,0	101,0	44,50	275	280	300	55
6	6,4	9,2	106,5	47,25	230	240	270	55
8	8,3	12,0	111,5	49,75	180	200	210	55
10	10,2	14,7	116,5	52,25	150	160	170	55
13	12,9	18,6	123,4	55,70	120	130	140	55

Max torque / Coppia max: 40 Nm

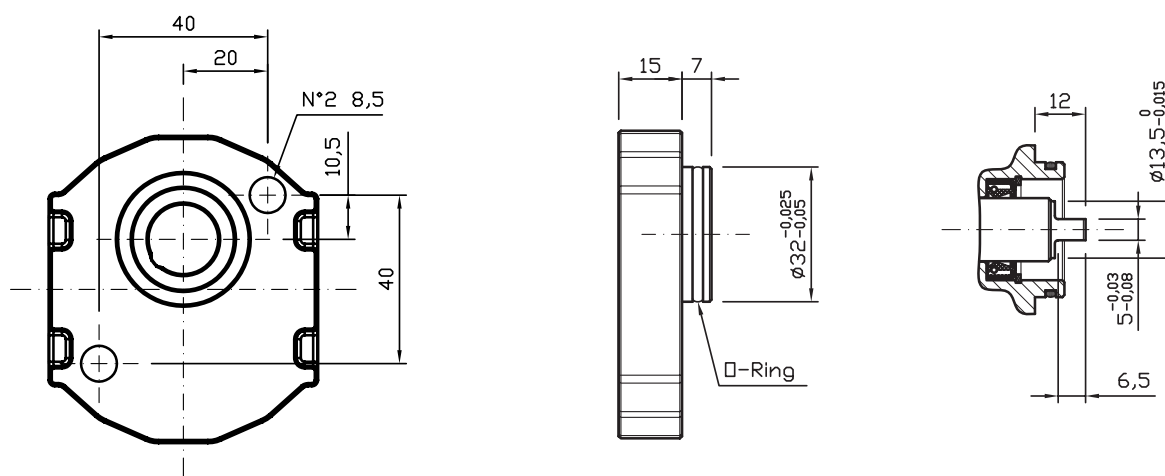

GR28 - TYPE / TIPO 1K-GL54								
Type Tipo	CC	L/min	Dimensions A Dimensioni A	Dimensions B Dimensioni B	Continuous Pressure Pressione continua	Intermittent Pressure Pressione intermittente (*)	Peak pressure Picco pressione (*)	Noise level Livello rumore
4	4,2	6,0	101,0	44,50	275	280	300	55
6	6,4	9,2	106,5	47,25	260	275	290	55
8	8,3	12,0	111,5	49,75	230	240	250	55
10	10,2	14,7	116,5	52,25	180	190	200	55
13	12,9	18,6	123,4	55,70	150	160	170	55

Max torque / Coppia max: 50 Nm

\* Intermittent: cycle 20 sec. ON & 3 sec. OFF - Peak: cycle 1 sec. ON & 3 sec. OFF - Intermittente: ciclo 20 sec. ON & 3 sec. OFF - Picco: ciclo 1 sec. ON & 3 sec. OFF

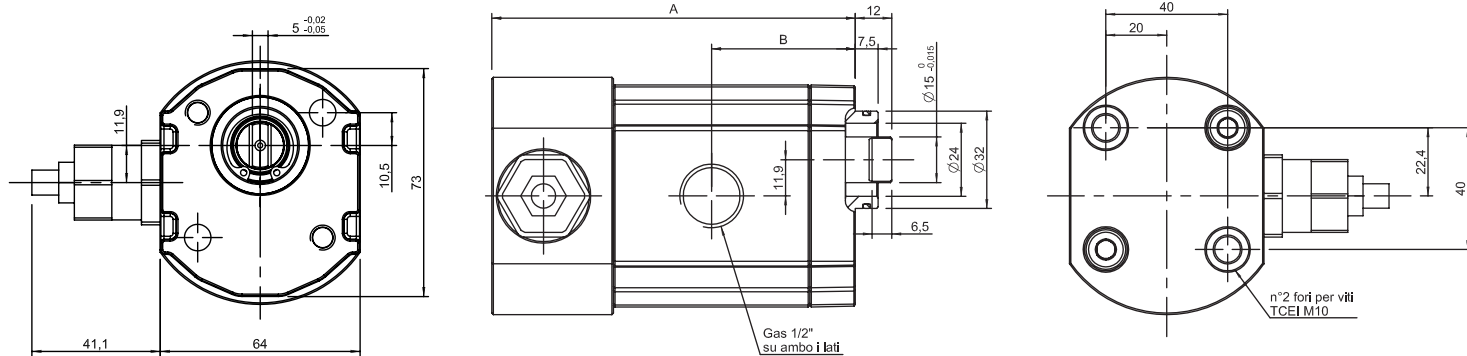

**GR28 - TYPE / TIPO 1K-GL54 (with safety valve / con valvola di massima)**

Type Tipo	CC	L/min	Dimensions A Dimensioni A	Dimensions B Dimensioni B	Continuous Pressure Pressione continua	Intermittent Pressure Pressione intermittente (*)	Peak pressure Picco pressione (*)	Noise level Livello rumore
4	4,2	6,0	114,0	44,5	275	280	300	55
6	6,4	9,2	119,5	47,25	260	275	290	55
8	8,3	12,0	124,5	49,75	230	240	250	55
10	10,2	14,7	129,5	52,25	180	190	200	55
13	12,9	18,6	136,4	55,70	150	160	170	55

Max torque / Coppia max: 50 Nm

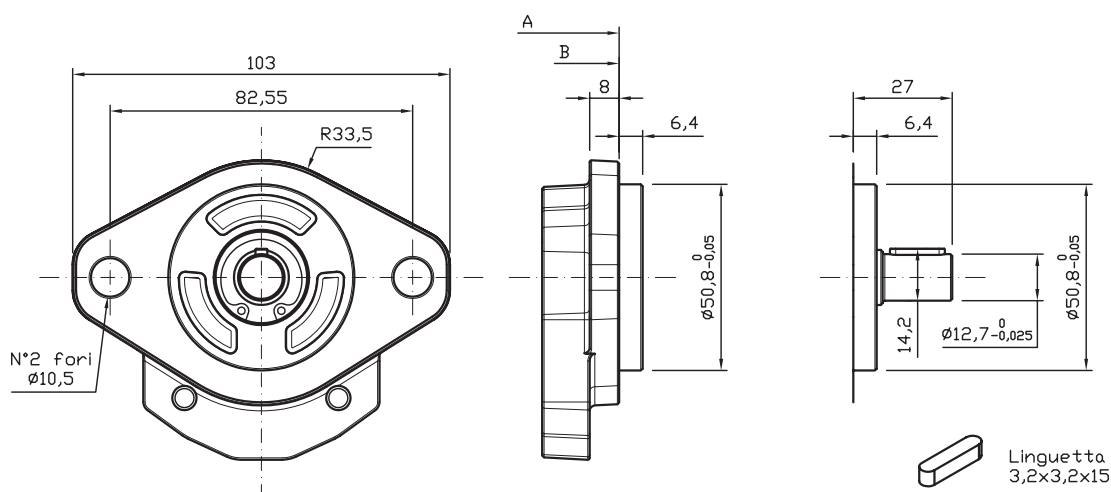

**GR28 - TYPE / TIPO SAEA-A - AC**

Type Tipo	CC	L/min	Dimensions A Dimensioni A	Dimensions B Dimensioni B	Continuous Pressure Pressione continua	Intermittent Pressure Pressione intermittente (*)	Peak pressure Picco pressione (*)	Noise level Livello rumore
4	4,2	6,0	107,0	50,50	234	238	255	55
6	6,4	9,2	112,5	53,25	234	238	255	55
8	8,3	12,0	117,5	55,75	209	221	238	55
10	10,2	14,7	122,5	58,25	189	213	230	55
13	12,9	18,6	129,4	61,70	170	196	213	55

Max torque / Coppia max: 60 Nm

\* Intermittent: cycle 20 sec. ON & 3 sec. OFF - Peak: cycle 1 sec. ON & 3 sec. OFF. Intermittente: ciclo 20 sec. ON & 3 sec. OFF - Picco: ciclo 1 sec. ON & 3 sec. OFF

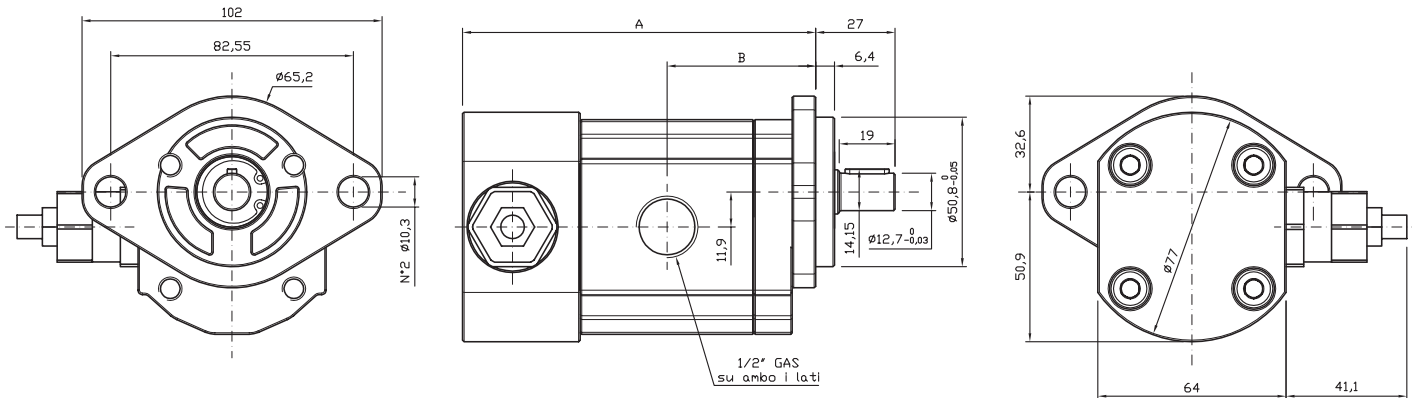

**GR28 - TYPE / TIPO SAEA-A - AC (with safety valve/con valvola di massima)**

Type Tipo	CC	L/min	Dimensions A Dimensioni A	Dimensions B Dimensioni B	Continuous Pressure Pressione continua	Intermittent Pressure Pressione intermittente (*)	Peak pressure Picco pressione (*)	Noise level Livello rumore
4	4,2	6,0	120,0	50,50	234	238	255	55
6	6,4	9,2	125,5	53,25	234	238	255	55
8	8,3	12,0	130,5	55,75	209	221	238	55
10	10,2	14,7	135,5	58,25	189	213	230	55
13	12,9	18,6	142,4	61,70	170	196	213	55

Max torque / Coppia max: 60 Nm

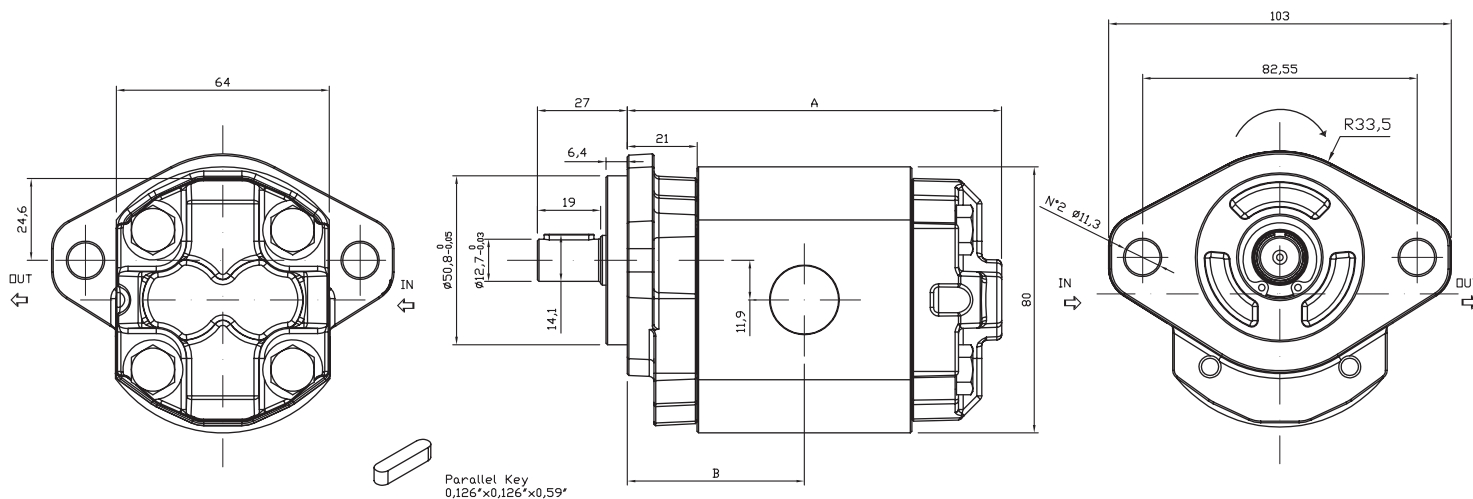

**GR28 - TYPE / TIPO SAE A-A SAE O-RING PORT 3/4 14 UNF 2B**

Type Tipo	CC	L/min	Dimensions A Dimensioni A	Dimensions B Dimensioni B	Continuous Pressure Pressione continua	Intermittent Pressure Pressione intermittente (*)	Peak pressure Picco pressione (*)	Noise level Livello rumore
4	4,2	6,0	107,0	50,5	234	238	255	55
6	6,4	9,2	112,5	53,25	234	238	255	55
8	8,3	12,0	117,5	55,75	209	221	238	55
10	10,2	14,7	122,5	58,25	189	213	230	55
13	12,9	18,6	129,4	61,70	170	196	213	55

Max torque / Coppia max: 60 Nm

\* Intermittent: cycle 20 sec. ON & 3 sec. OFF - Peak: cycle 1 sec. ON & 3 sec OFF. Intermittente: ciclo 20 sec. ON & 3 sec. OFF - Picco: ciclo 1 sec. ON & 3 sec OFF

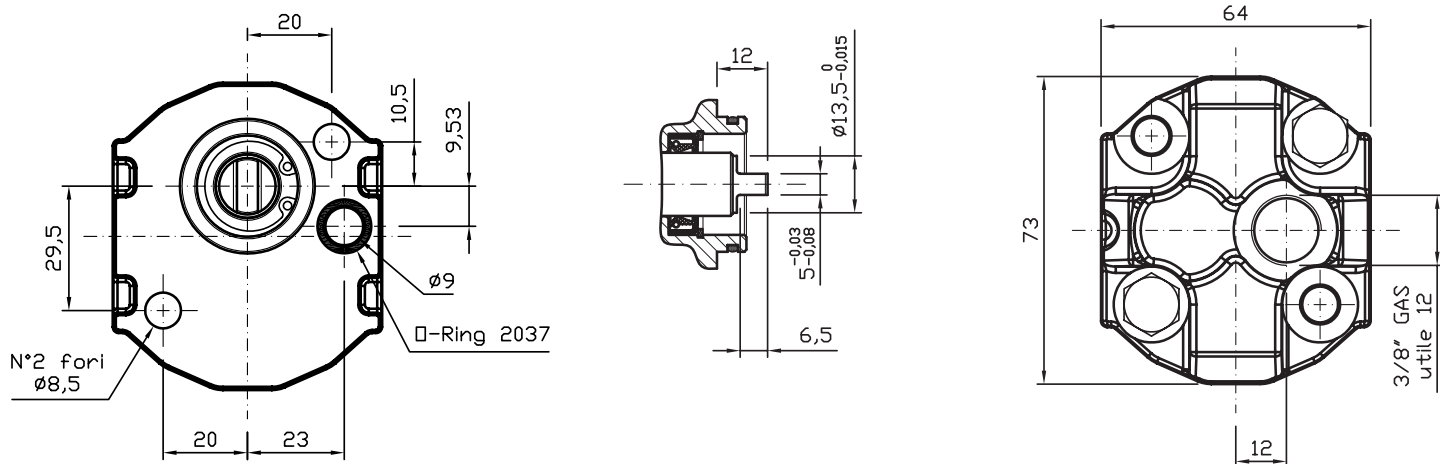

GR28 - TYPE / TIPO 1L-GL54							
Type Tipo	CC	L/min	Dimensions A Dimensioni A	Continuous Pressure Pressione continua	Intermittent Pressure Pressione intermittente (*)	Peak pressure Picco pressione (*)	Noise level Livello rumore
4	4,2	6,0	101,0	275	280	300	55
6	6,4	9,2	106,5	260	275	290	55
8	8,3	12,0	111,5	230	240	250	55
10	10,2	14,7	116,5	180	190	200	55
13	12,9	18,6	123,4	150	160	170	55

Max torque / Coppia max: 50 Nm

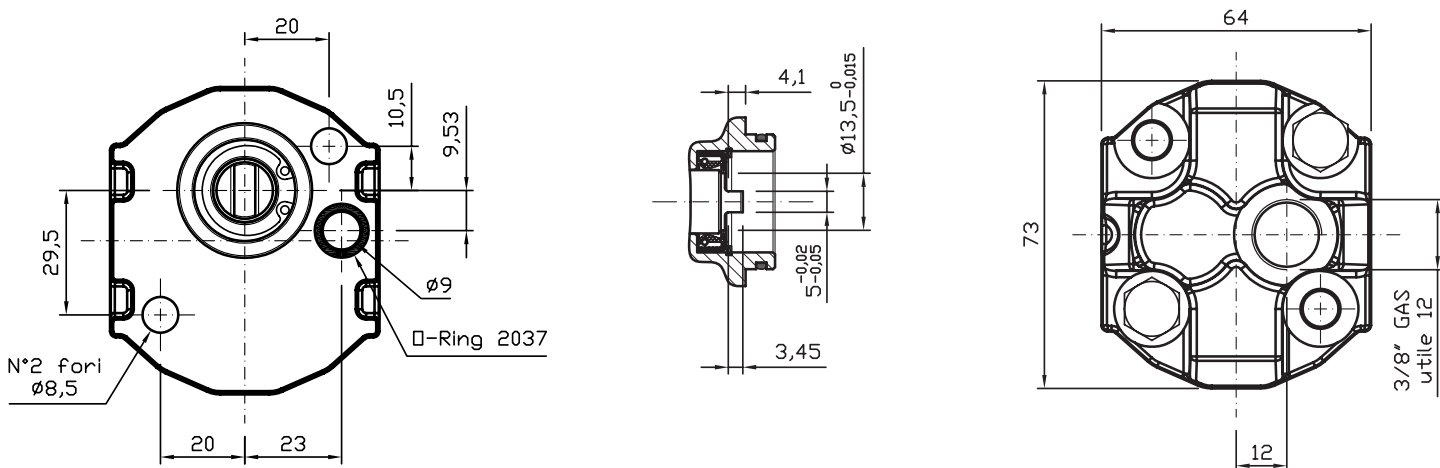

GR28 - TYPE / TIPO 1L-G54							
Type Tipo	CC	L/min	Dimensions A Dimensioni A	Continuous Pressure Pressione continua	Intermittent Pressure Pressione intermittente (*)	Peak pressure Picco pressione (*)	Noise level Livello rumore
4	4,2	6,0	101,0	275	280	300	55
6	6,4	9,2	106,5	230	240	270	55
8	8,3	12,0	111,5	180	200	210	55
10	10,2	14,7	116,5	150	160	170	55
13	12,9	18,6	123,4	120	130	140	55

Max torque / Coppia max: 40 Nm

\* Intermittent: cycle 20 sec. ON & 3 sec. OFF - Peak: cycle 1 sec. ON & 3 sec OFF. Intermittente: ciclo 20 sec. ON & 3 sec. OFF - Picco: ciclo 1 sec. ON & 3 sec OFF

## GR33 - Dimensional drawings / Disegni dimensionali

### GR33 SHAFT AND FLANGE TYPE AND DIMENSIONS / TIPO ALBERO E FLANGE E DIMENSIONI

#### Group 2 pumps / Pompe gruppo 2

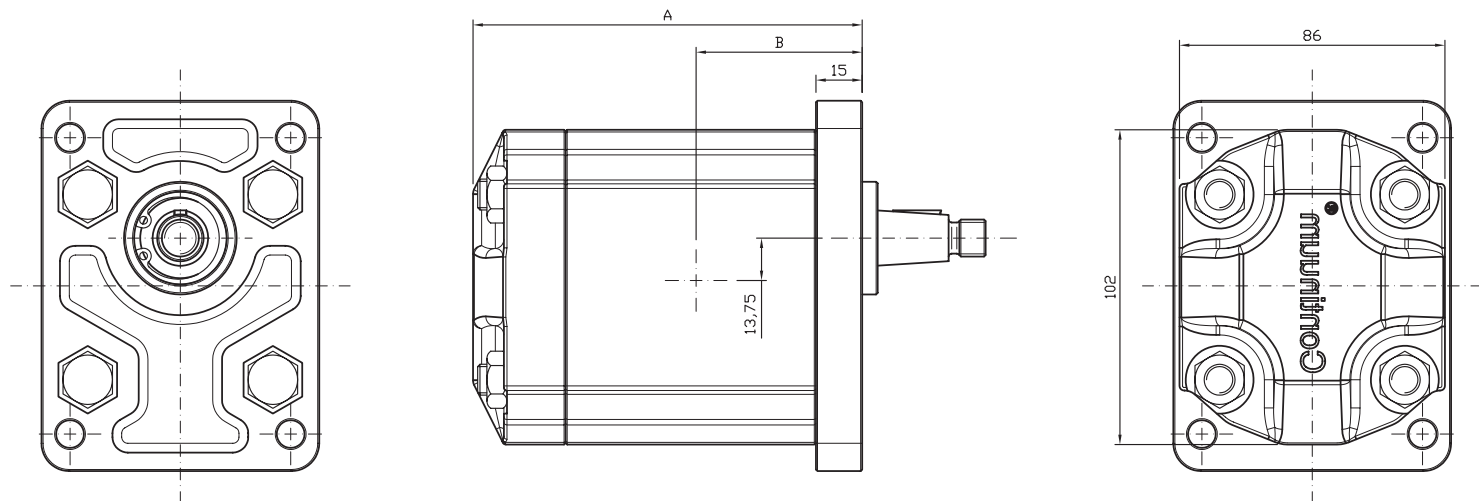

#### Available flanges and shafts / Flange ed alberi disponibili

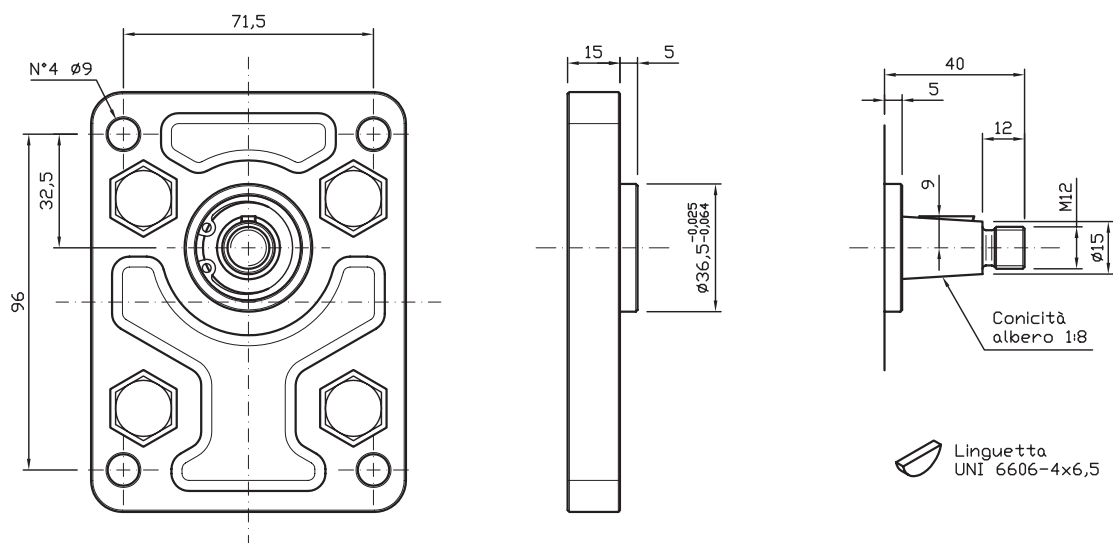

#### GR33 - TYPE / TIPO 2-C4

Type Tipo	CC	L/min	Dimensions A Dimensioni A	Dimensions B Dimensioni B	Continuous Pressure Pressione continua	Intermittent Pressure Pressione intermittente (*)	Peak pressure Picco pressione (*)	Noise level Livello rumore
10	10,1	14,5	122,5	53,75	275	280	300	55
13	12,6	18,1	127,4	56,20	265	270	290	55
15	15,2	21,8	132,4	58,70	241	250	270	55
18	18,2	26,1	138,2	61,60	206	250	270	55

Max torque / Coppia max: 210 Nm

\* Intermittent: cycle 20 sec. ON & 3 sec. OFF - Peak: cycle 1 sec. ON & 3 sec OFF. Intermittente: ciclo 20 sec. ON & 3 sec. OFF - Picco: ciclo 1 sec. ON & 3 sec OFF

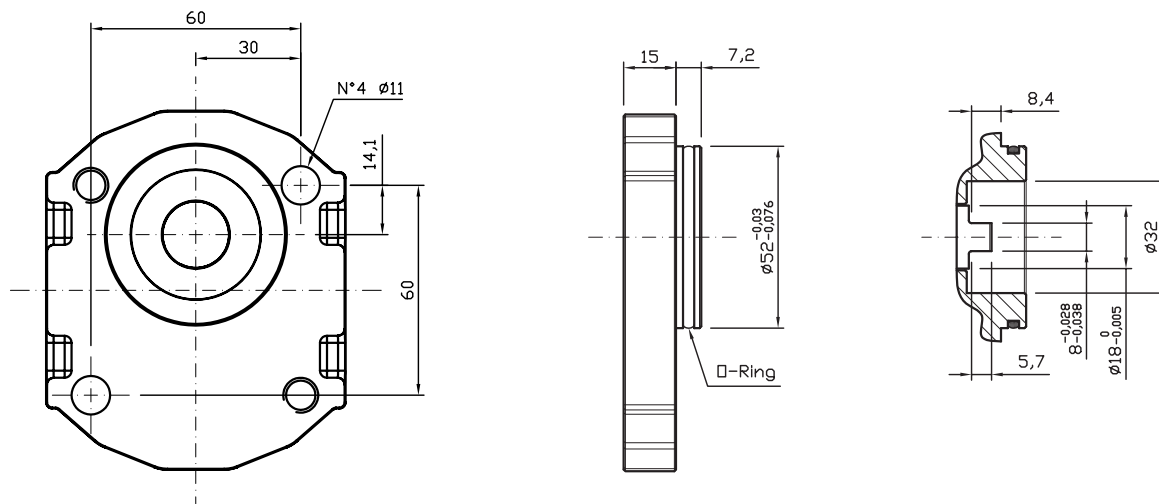

GR33 - TYPE / TIPO 2BK7-AG								
Type Tipo	CC	L/min	Dimensions A Dimensioni A	Dimensions B Dimensioni B	Continuous Pressure Pressione continua	Intermittent Pressure Pressione intermittente (*)	Peak pressure Picco pressione (*)	Noise level Livello rumore
10	10,1	14,5	122,5	53,75	275	280	300	55
13	12,6	18,1	127,4	56,20	265	270	290	55
15	15,2	21,8	132,4	58,70	241	250	270	55
18	18,2	26,1	138,2	61,60	206	250	270	55

Max torque / Coppia max: 110 Nm

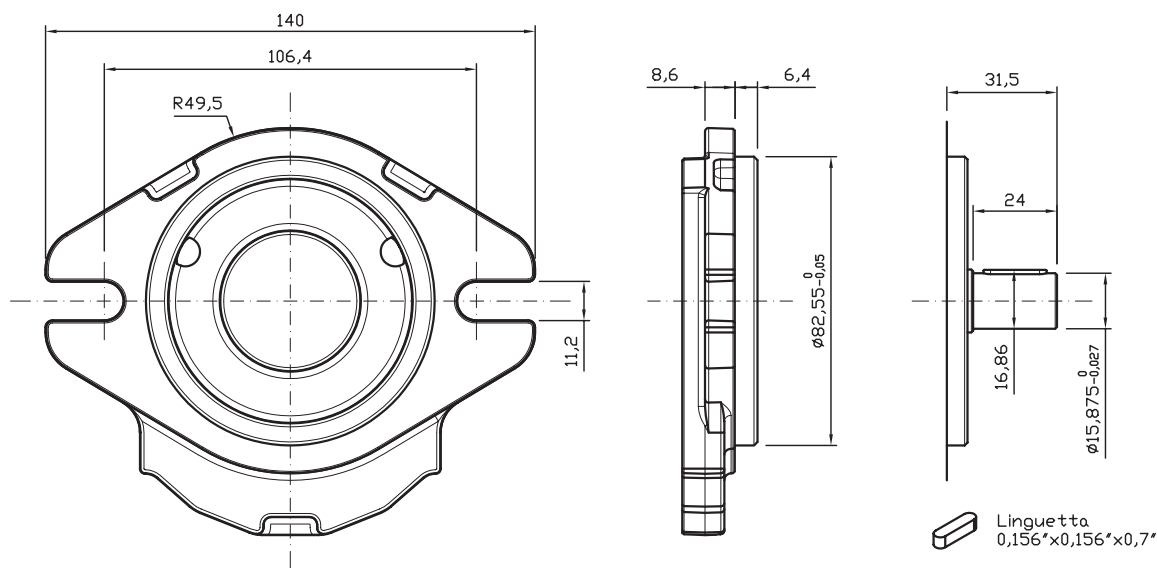

GR33 - TYPE / TIPO SAEA-AC								
Type Tipo	CC	L/min	Dimensions A Dimensioni A	Dimensions B Dimensioni B	Continuous Pressure Pressione continua	Intermittent Pressure Pressione intermittente (*)	Peak pressure Picco pressione (*)	Noise level Livello rumore
10	10,1	14,5	122,5	53,75	275	280	300	55
13	12,6	18,1	127,4	56,20	265	270	290	55
15	15,2	21,8	132,4	58,70	241	250	270	55
18	18,2	26,1	138,2	61,60	206	250	270	55

Max torque / Coppia max: 140 Nm

\* Intermittent: cycle 20 sec. ON & 3 sec. OFF - Peak: cycle 1 sec. ON & 3 sec OFF. Intermittente: ciclo 20 sec. ON & 3 sec. OFF - Picco: ciclo 1 sec. ON & 3 sec OFF

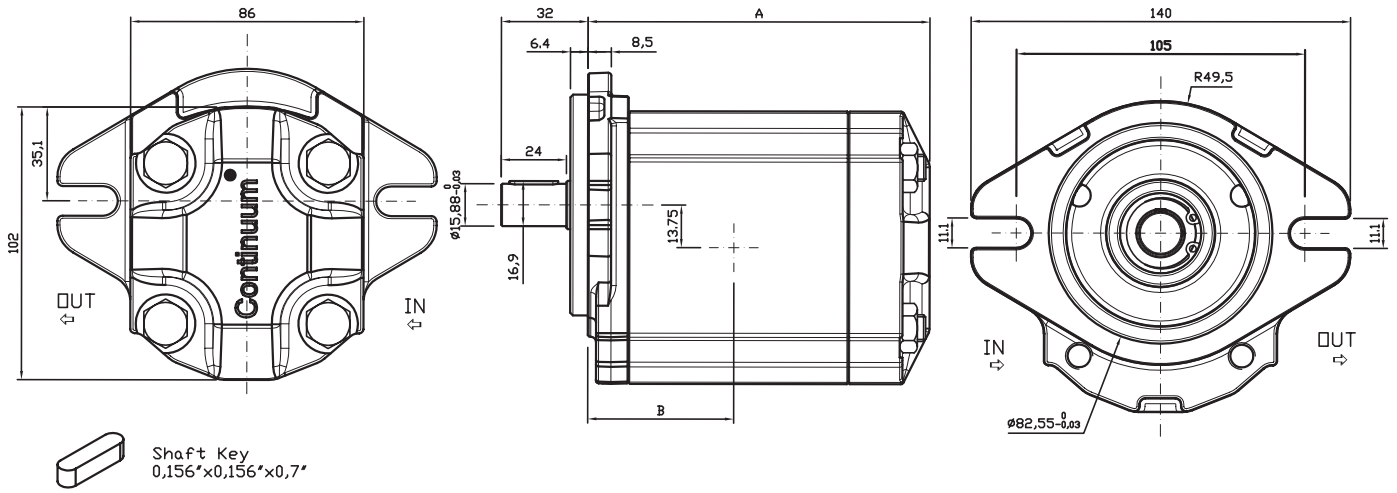

GR33 - TYPE / TIPO SAEA-AC SAE O-RING UNF								
Type Tipo	CC	L/min	Dimensions A Dimensioni A	Dimensions B Dimensioni B	Continuous Pressure Pressione continua	Intermittent Pressure Pressione intermittente (*)	Peak pressure Picco pressione (*)	Noise level Livello rumore
10	10,1	14,5	122,5	53,75	275	280	300	55
13	12,6	18,1	127,4	56,20	265	270	290	55
15	15,2	21,8	132,4	58,70	241	250	270	55
18	18,2	26,1	138,2	61,60	206	250	270	55

Max torque / Coppia max: 140 Nm

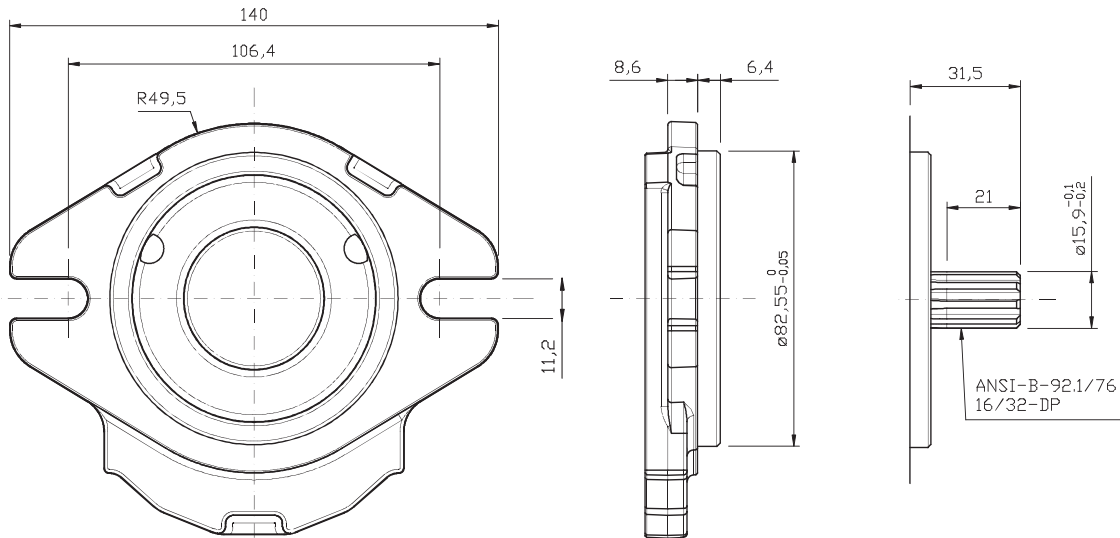

GR33 - TYPE / TIPO SAEA-T9								
Type Tipo	CC	L/min	Dimensions A Dimensioni A	Dimensions B Dimensioni B	Continuous Pressure Pressione continua	Intermittent Pressure Pressione intermittente (*)	Peak pressure Picco pressione (*)	Noise level Livello rumore
10	10,1	14,5	122,5	53,75	275	280	300	55
13	12,6	18,1	127,4	56,20	265	270	290	55
15	15,2	21,8	132,4	58,70	241	250	270	55
18	18,2	26,1	138,2	61,60	206	250	270	55

Max torque / Coppia max: 190 Nm

\* Intermittent: cycle 20 sec. ON & 3 sec. OFF - Peak: cycle 1 sec. ON & 3 sec OFF. Intermittente: ciclo 20 sec. ON & 3 sec. OFF - Picco: ciclo 1 sec. ON & 3 sec OFF



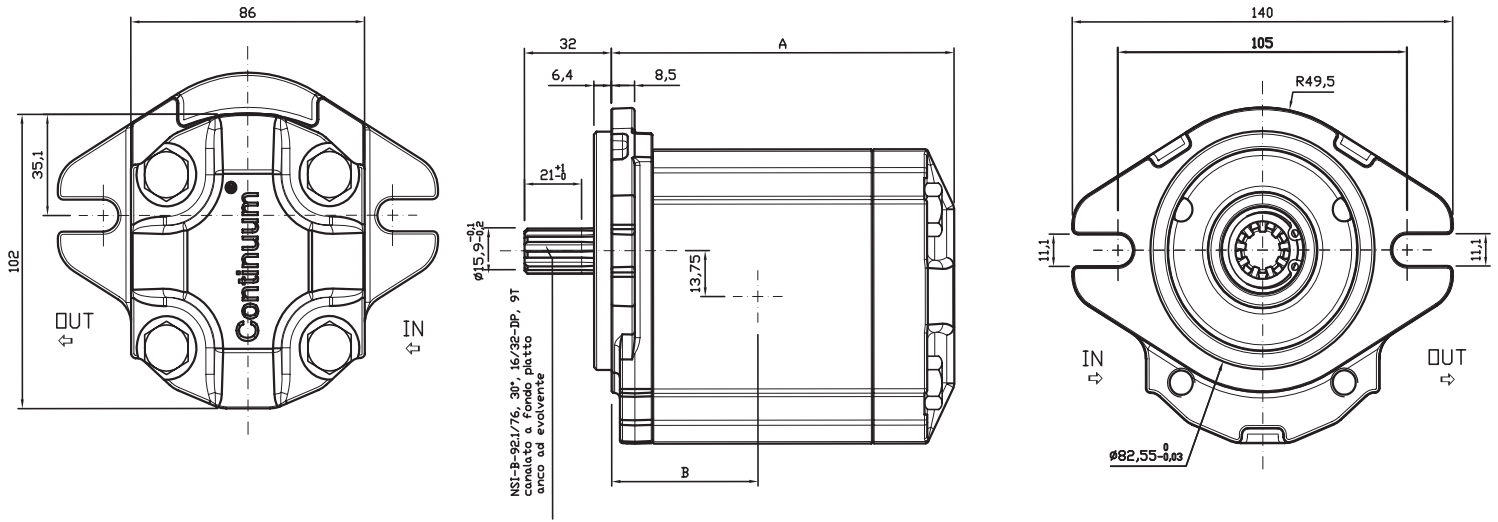

GR33 - TYPE / TIPO SAEA-T9 SAE O-RING UNF								
Type Tipo	CC	L/min	Dimensions A Dimensioni A	Dimensions B Dimensioni B	Continuous Pressure Pressione continua	Intermittent Pressure Pressione intermittente (*)	Peak pressure Picco pressione (*)	Noise level Livello rumore
10	10,1	14,5	122,5	53,75	275	280	300	55
13	12,6	18,1	127,4	56,20	265	270	290	55
15	15,2	21,8	132,4	58,70	241	250	270	55
18	18,2	26,1	138,2	61,60	206	250	270	55

Max torque / Coppia max: 190 Nm

\* Intermittent: cycle 20 sec. ON & 3 sec. OFF - Peak: cycle 1 sec. ON & 3 sec OFF. Intermittente: ciclo 20 sec. ON & 3 sec. OFF - Picco: ciclo 1 sec. ON & 3 sec OFF

INLET OUTLET PORTS / PORTE DI ASPIRAZIONE E MANDATA (Suction / Pressure)

Type G / Tipo G

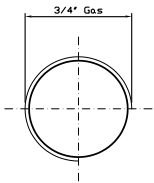

Type Q / Tipo Q

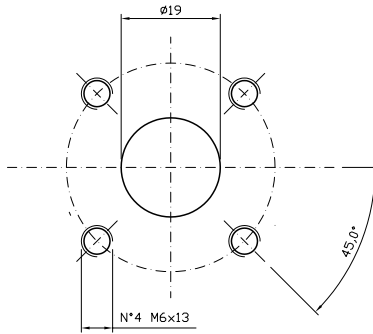

Type M / Tipo M

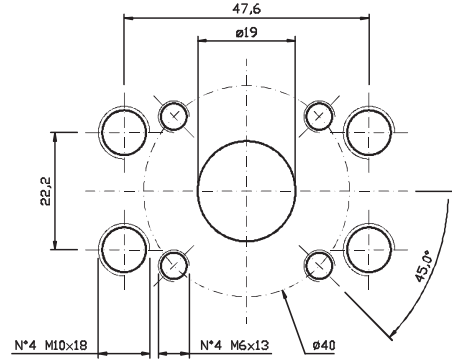

UNF INLET OUTLET PORTS / PORTE DI ASPIRAZIONE E MANDATA UNF - Type U / Tipo U

SAE O-Ring Port 12 thread  
ANSI B1.1 1 1/16 UN-2B

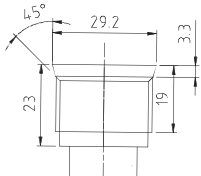

SAE O-Ring Port 16 thread  
ANSI B1.1 1 5/16 12 UN-2B

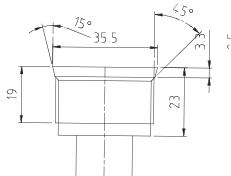

Suction

SAE O-Ring Port 10 thread  
ANSI B1.1 1 7/8 14 UNF-2B

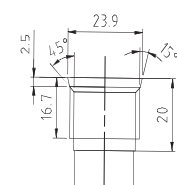

SAE O-Ring Port 12 thread  
ANSI B1.1 1 1/16 12 UN-2B

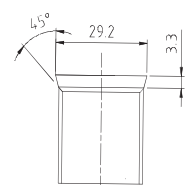

Pressure

Suction/Pressure UNF ports possible configuration  
Possibili combinazioni porte di aspirazione/mandata di tipo UNF

Pump	Suction port	Pressure port
GR33 - 10 cc	SAE O-Ring port 12	SAE O-Ring port 10
GR33 - 13 cc	SAE O-Ring port 12	SAE O-Ring port 10
GR33 - 15 cc	SAE O-Ring port 12	SAE O-Ring port 10
GR33 - 18 cc	SAE O-Ring port 16	SAE O-Ring port 12

## GR38 - Dimensional drawings / Disegni dimensionali

### GR38 SHAFT AND FLANGE TYPE AND DIMENSIONS / TIPO ALBERO E FLANGE E DIMENSIONI

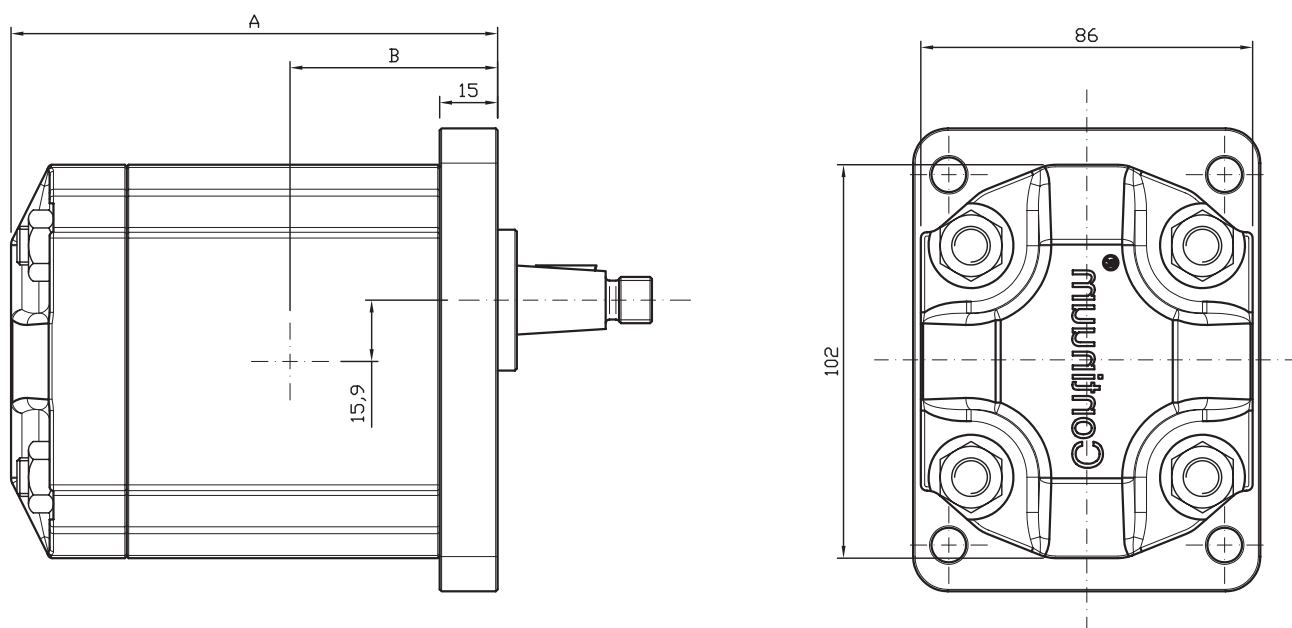

### Available flanges and shafts / Flange ed alberi disponibili

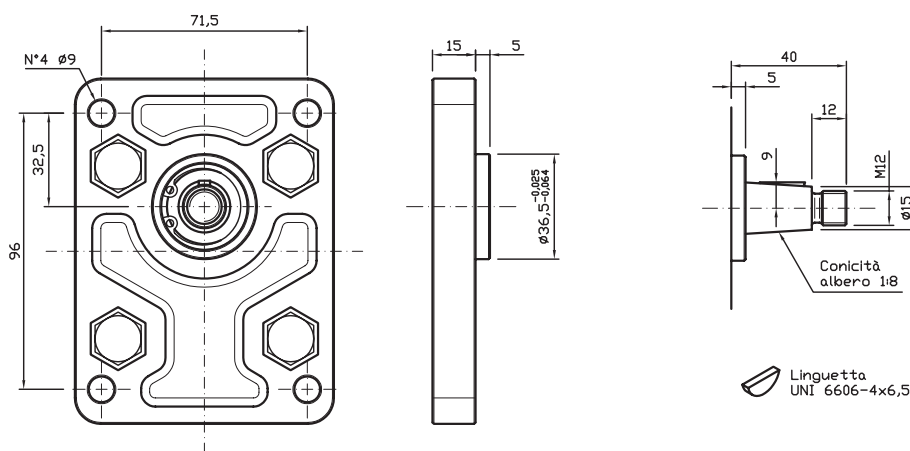

GR38 - TYPE / TIPO 2-C4

Type Tipo	CC	L/min	Dimensions A Dimensioni A	Dimensions B Dimensioni B	Continuous Pressure Pressione continua	Intermittent Pressure Pressione intermittente (*)	Peak pressure Picco pressione (*)	Noise level Livello rumore
16	15,9	22,8	126,0	55,50	265	280	300	55
18	17,9	25,8	129,0	57,00	247	260	280	55
20	20,0	28,8	132,0	58,50	230	250	270	55
22	22,1	31,8	135,0	60,00	222	240	260	55
25	25,2	36,2	139,5	62,25	200	210	220	55
28	28,3	40,7	144,0	64,50	180	190	200	55

Max torque / Coppia max: 210 Nm

\* Intermittent: cycle 20 sec. ON & 3 sec. OFF - Peak: cycle 1 sec. ON & 3 sec OFF. Intermittente: ciclo 20 sec. ON & 3 sec. OFF - Picco: ciclo 1 sec. ON & 3 sec OFF

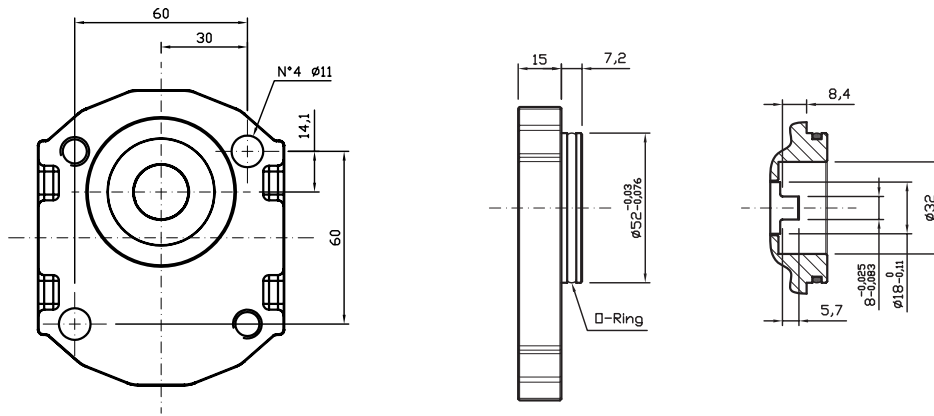

GR38 - TYPE / TIPO 2BK7-AG								
Type Tipo	CC	L/min	Dimensions A Dimensioni A	Dimensions B Dimensioni B	Continuous Pressure Pressione continua	Intermittent Pressure Pressione intermittente (*)	Peak pressure Picco pressione (*)	Noise level Livello rumore
16	15,9	22,8	126,0	55,50	265	280	300	55
18	17,9	25,8	129,0	57,00	247	260	280	55
20	20,0	28,8	132,0	58,50	230	250	260	55
22	22,1	31,8	135,0	60,00	210	230	240	55
25	25,2	36,2	139,5	62,25	200	210	220	55
28	28,3	40,7	144,0	64,50	180	190	200	55

Max torque / Coppia max: 110 Nm

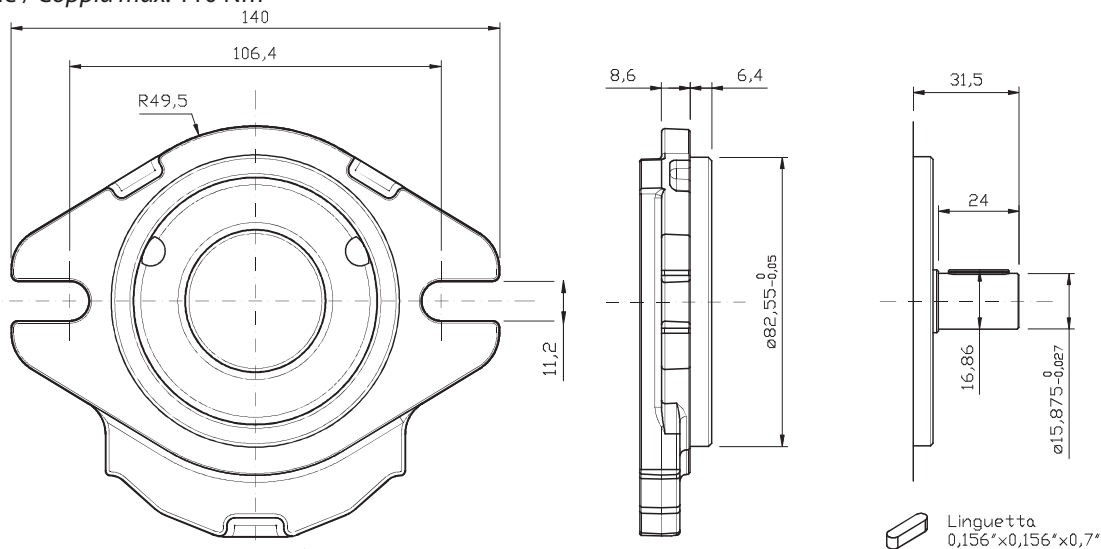

GR38 - TYPE / TIPO SAEA-AC								
Type Tipo	CC	L/min	Dimensions A Dimensioni A	Dimensions B Dimensioni B	Continuous Pressure Pressione continua	Intermittent Pressure Pressione intermittente (*)	Peak pressure Picco pressione (*)	Noise level Livello rumore
16	15,9	22,8	126,0	55,50	265	280	300	55
18	17,9	25,8	129,0	57,00	247	260	280	55
20	20,0	28,8	132,0	58,50	230	250	270	55
22	22,1	31,8	135,0	60,00	222	240	260	55
25	25,2	36,2	139,5	62,25	200	210	220	55
28	28,3	40,7	144,0	64,50	180	190	200	55

Max torque / Coppia max: 140 Nm

\* Intermittent: cycle 20 sec. ON & 3 sec. OFF - Peak: cycle 1 sec. ON & 3 sec OFF. Intermittente: ciclo 20 sec. ON & 3 sec. OFF - Picco: ciclo 1 sec. ON & 3 sec OFF

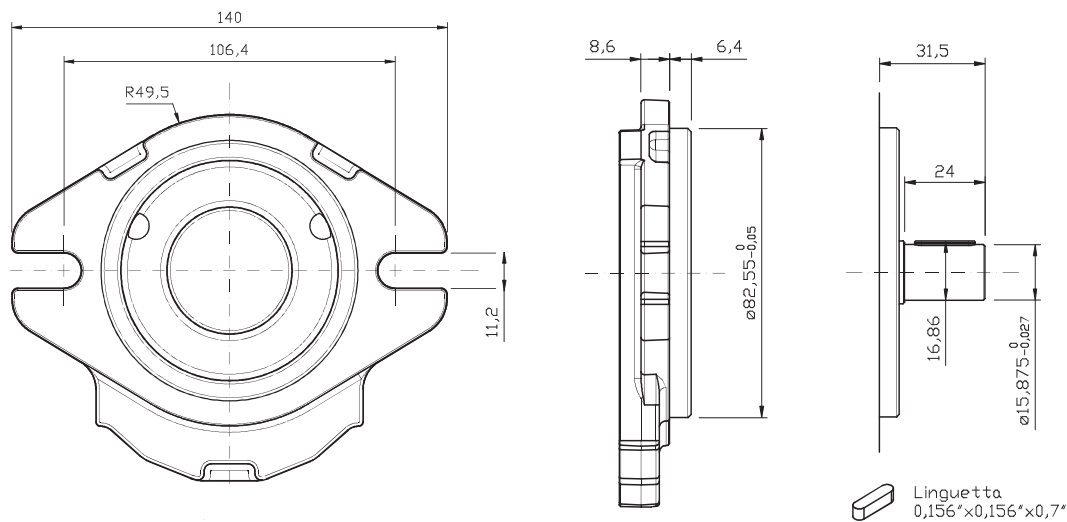

**GR38 - TYPE / TIPO SAEA-AC SAE O-RING PORT UNF**

Type Tipo	CC	L/min	Dimensions A Dimensioni A	Dimensions B Dimensioni B	Continuous Pressure Pressione continua	Intermittent Pressure Pressione intermittente (*)	Peak pressure Picco pressione (*)	Noise level Livello rumore
16	15,9	22,8	126,0	55,50	265	280	300	55
18	17,9	25,8	129,0	57,00	247	260	280	55
20	20,0	28,8	132,0	58,50	230	250	270	55
22	22,1	31,8	135,0	60,00	222	240	260	55
25	25,2	36,2	139,5	62,25	200	210	220	55
28	28,3	40,7	144,0	64,50	180	190	200	55

Max torque / Coppia max: 140 Nm

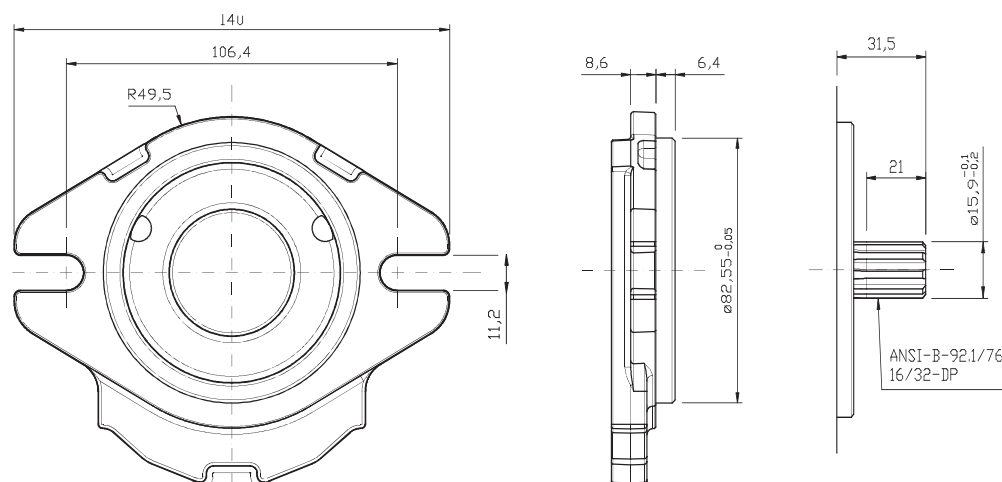

**GR38 - TYPE / TIPO SAEA-T9**

Type Tipo	CC	L/min	Dimensions A Dimensioni A	Dimensions B Dimensioni B	Continuous Pressure Pressione continua	Intermittent Pressure Pressione intermittente (*)	Peak pressure Picco pressione (*)	Noise level Livello rumore
16	15,9	22,8	126,0	55,50	265	280	300	55
18	17,9	25,8	129,0	57,00	247	260	280	55
20	20,0	28,8	132,0	58,50	230	250	270	55
22	22,1	31,8	135,0	60,00	222	240	260	55
25	25,2	36,2	139,5	62,25	200	210	220	55
28	28,3	40,7	144,0	64,50	180	190	200	55

Max torque / Coppia max: 190 Nm

\* Intermittent: cycle 20 sec. ON & 3 sec. OFF - Peak: cycle 1 sec. ON & 3 sec OFF. Intermittente: ciclo 20 sec. ON & 3 sec. OFF - Picco: ciclo 1 sec. ON & 3 sec OFF

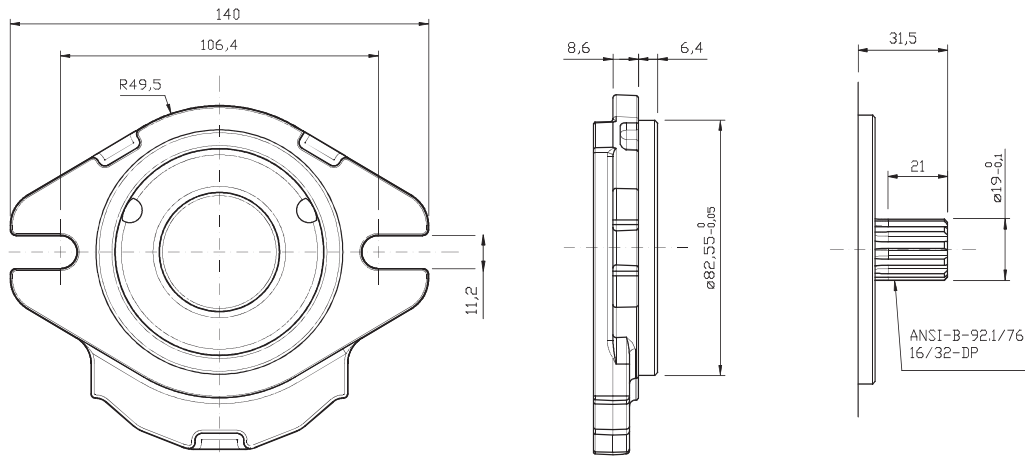

**GR38 - TYPE / TIPO SAE-A11**

Type Tipo	CC	L/min	Dimensions A Dimensioni A	Dimensions B Dimensioni B	Continuous Pressure Pressione continua	Intermittent Pressure Pressione intermittente (*)	Peak pressure Picco pressione (*)	Noise level Livello rumore
16	15,9	22,8	126,0	55,50	265	280	300	55
18	17,9	25,8	129,0	57,00	247	260	280	55
20	20,0	28,8	132,0	58,50	230	250	270	55
22	22,1	31,8	135,0	60,00	222	250	270	55
25	25,2	36,2	139,5	62,25	208	250	270	55
28	28,3	40,7	144,0	64,50	197	250	270	55

Max torque / Coppia max: 210 Nm

\* Intermittent: cycle 20 sec. ON & 3 sec. OFF - Peak: cycle 1 sec. ON & 3 sec OFF. Intermittente: ciclo 20 sec. ON & 3 sec. OFF - Picco: ciclo 1 sec. ON & 3 sec OFF

**INLET OUTLET PORTS / PORTE DI ASPIRAZIONE E MANDATA (Suction / Pressure)**

**Type G / Tipo G**

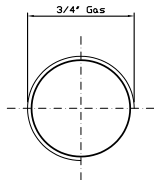

**Type Q / Tipo Q**

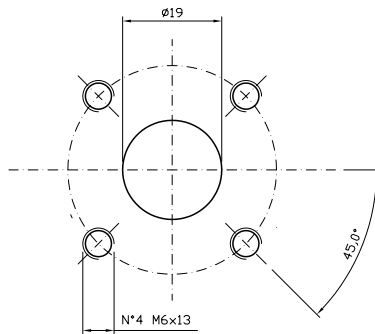

**Type M / Tipo M**

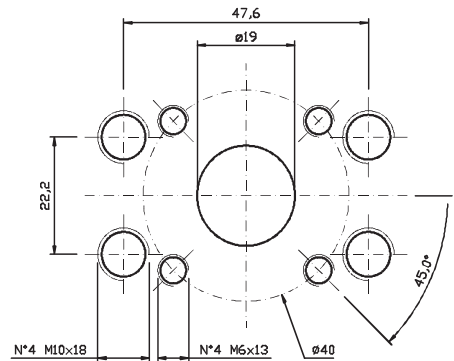

**UNF INLET OUTLET PORTS / PORTE DI ASPIRAZIONE E MANDATA UNF - Type U / Tipo U**

SAE O-Ring Port 12 thread  
ANSI B1.1 1 1/16 UN-2B

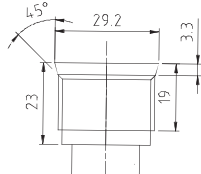

SAE O-Ring Port 16 thread  
ANSI B1.1 1 5/16 12 UN-2B

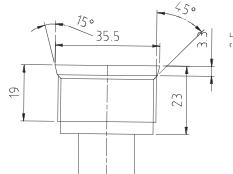

**Suction**

SAE O-Ring Port 10 thread  
ANSI B1.1 1 7/8 14 UNF-2B

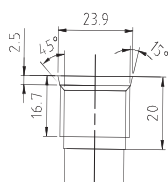

SAE O-Ring Port 12 thread  
ANSI B1.1 1 1/16 12 UN-2B

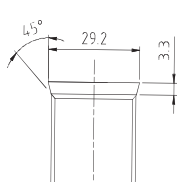

**Pressure**

Suction/Pressure UNF ports possible configuration  
Possibili combinazioni porte di aspirazione/mandata di tipo UNF

Pump	Suction port	Pressure port
GR38 - 16 cc	SAE O-Ring port 12	SAE O-Ring port 10
GR38 - 18 cc	SAE O-Ring port 16	SAE O-Ring port 12
GR38 - 20 cc	SAE O-Ring port 16	SAE O-Ring port 12
GR38 - 22 cc	SAE O-Ring port 16	SAE O-Ring port 12
GR38 - 25 cc	SAE O-Ring port 16	SAE O-Ring port 12
GR38 - 28 cc	SAE O-Ring port 16	SAE O-Ring port 12
GR38 - 50 cc	SAE O-Ring port 16	SAE O-Ring port 12

## GR47 - Dimensional drawings / Disegni dimensionali

### GR47 SHAFT AND FLANGE TYPE AND DIMENSIONS / TIPO ALBERO E FLANGE E DIMENSIONI

#### Group 3 pumps / Pompe gruppo 3

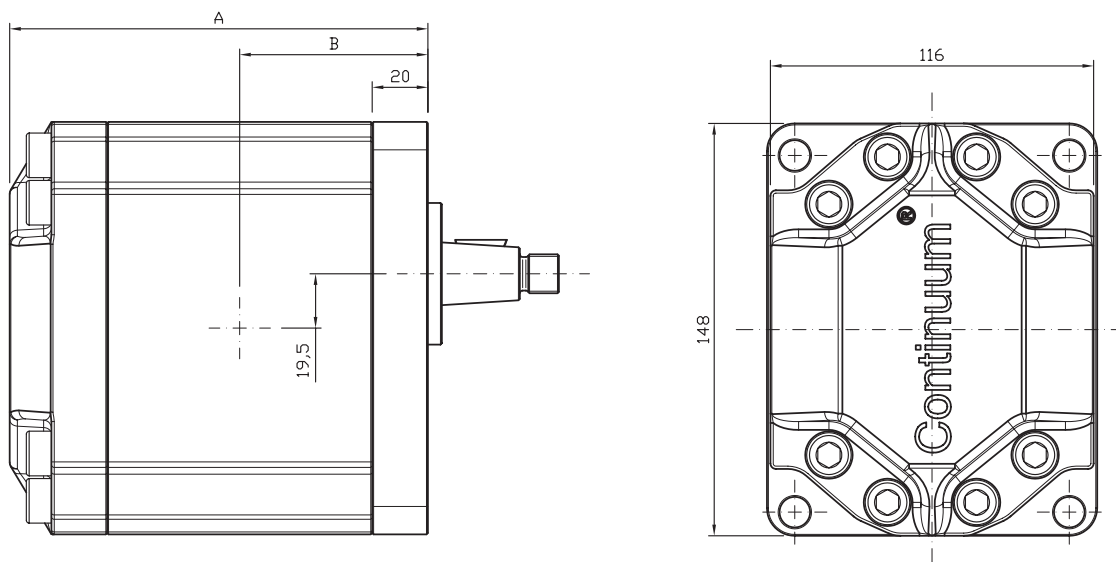

#### Available flanges and shafts / Flange ed alberi disponibili

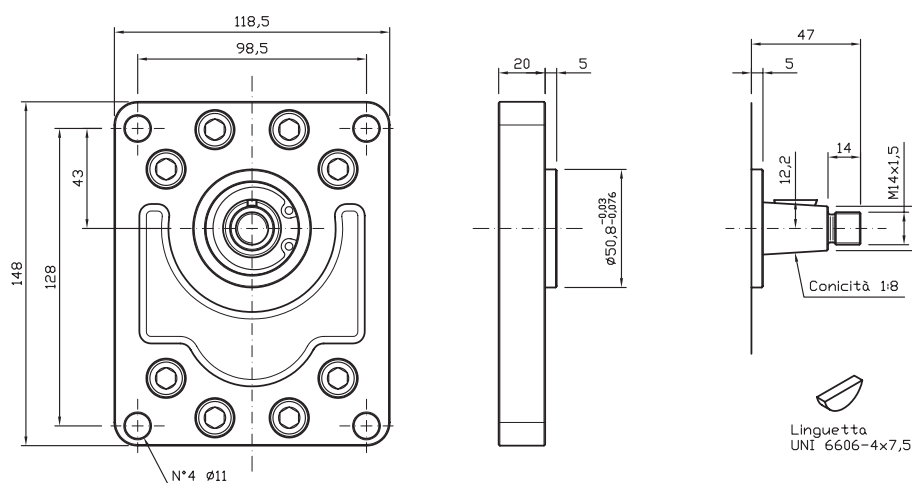

#### GR47 - TYPE / TIPO 3-C9

Type Tipo	CC	L/min	Dimensions A Dimensioni A	Dimensions B Dimensioni B	Continuous Pressure Pressione continua	Intermittent Pressure Pressione intermittente (*)	Peak pressure Picco pressione (*)	Noise level Livello rumore
28	28,0	40,3	151,5	67,50	270	280	300	57
32	32,2	46,3	155,5	69,50	252	270	280	57
36	36,3	52,3	159,5	71,50	239	250	270	57
40	40,5	58,3	163,5	73,50	225	250	270	57
45	45,5	65,0	168,0	75,75	213	250	270	57
50	50,3	72,4	173,0	78,25	202	250	270	57

Max torque / Coppia max: 320 Nm

\* Intermittent: cycle 20 sec. ON & 3 sec. OFF - Peak: cycle 1 sec. ON & 3 sec OFF. Intermittente: ciclo 20 sec. ON & 3 sec. OFF - Picco: ciclo 1 sec. ON & 3 sec OFF

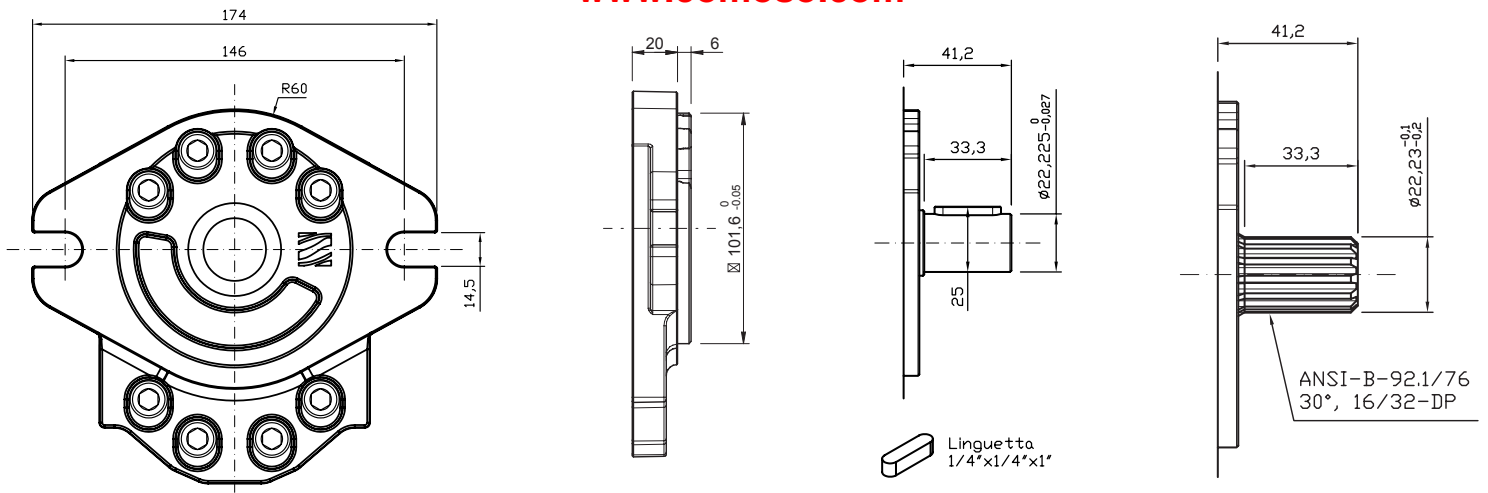

GR47 - TYPE / TIPO SAEB-AC / SAEB-T13								
Type Tipo	CC	L/min	Dimensions A Dimensioni A	Dimensions B Dimensioni B	Continuous Pressure Pressione continua	Intermittent Pressure Pressione intermittente (*)	Peak pressure Picco pressione (*)	Noise level Livello rumore
28	28,0	40,3	151,5	67,50	270	280	300	57
32	32,2	46,3	155,5	69,50	252	270	280	57
36	36,3	52,3	159,5	71,50	239	250	270	57
40	40,5	58,3	163,5	73,50	225	250	270	57
45	45,5	65,0	168,0	75,75	213	250	270	57
50	50,3	72,4	173,0	78,25	202	250	270	57

Max torque / Coppia max: 450 Nm - Max torque / Coppia max: 600 Nm

\* Intermittent: cycle 20 sec. ON & 3 sec. OFF - Peak: cycle 1 sec. ON & 3 sec OFF. Intermittente: ciclo 20 sec. ON & 3 sec. OFF - Picco: ciclo 1 sec. ON & 3 sec OFF

GR47 INLET OUTLET PORTS / PORTE DI ASPIRAZIONE E MANDATA

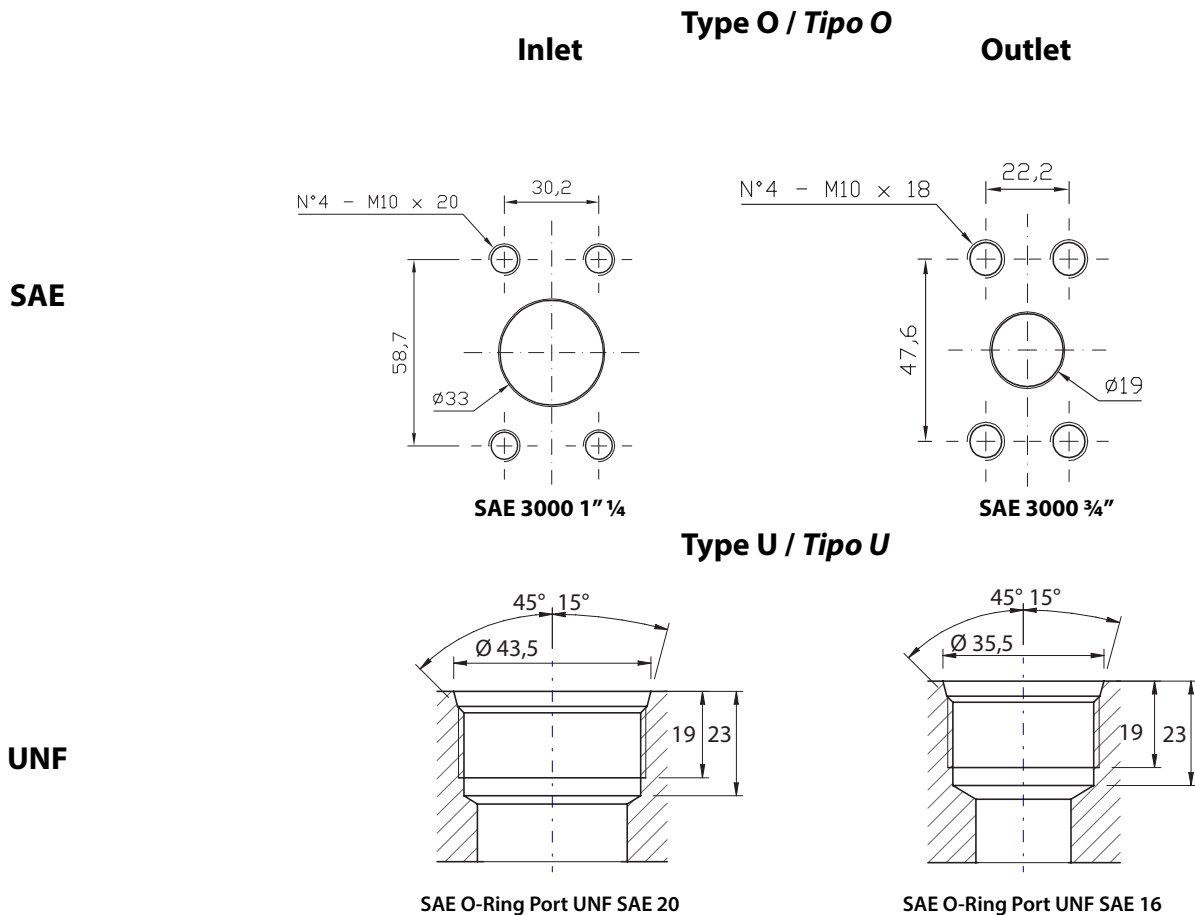

## GR55 - Dimensional drawings / Disegni dimensionali

### GR55 SHAFT AND FLANGE TYPE AND DIMENSIONS / TIPO ALBERO E FLANGE E DIMENSIONI

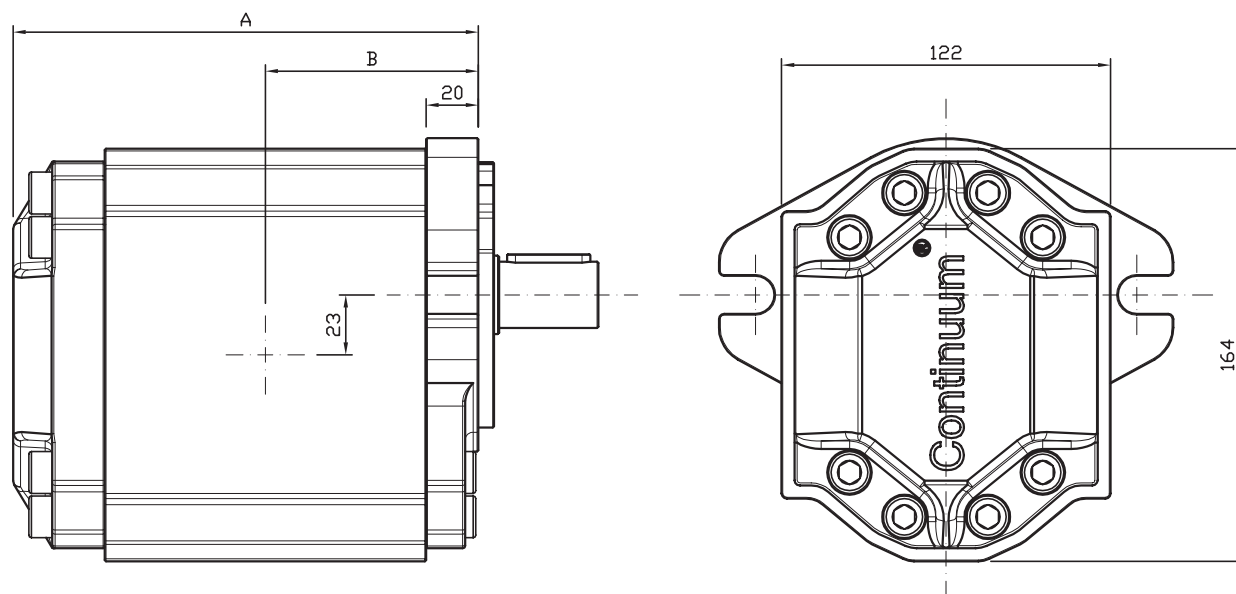

### Available flanges and shafts / Flange ed alberi disponibili

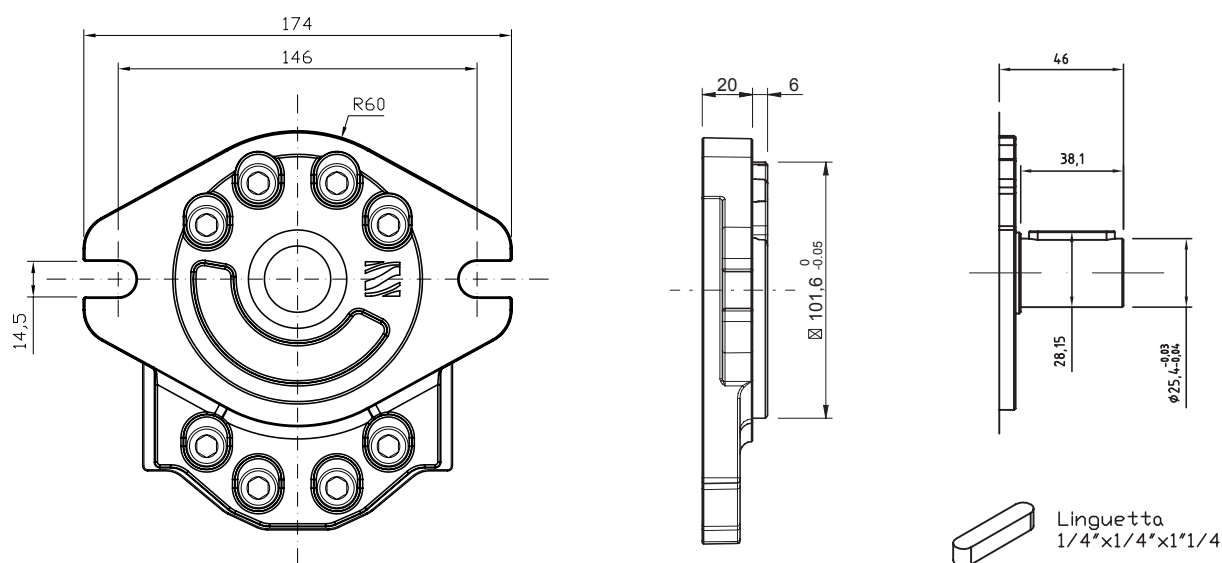

### GR55 - TYPE / TIPO SAEB-AC

Type Tipo	CC	L/min	Dimensions A Dimensioni A	Dimensions B Dimensioni B	Continuous Pressure Pressione continua	Intermittent Pressure Pressione intermittente (*)	Peak pressure Picco pressione (*)	Noise level Livello rumore
50	50,5	72,7	179,5	81,50	275	280	300	57
63	63,5	91,4	188,5	86,00	249	260	280	57
75	75,0	108,1	196,5	90,00	229	250	270	57
90	90,9	130,9	207,5	95,5	178	240	260	57

\* Intermittent: cycle 20 sec. ON & 3 sec. OFF - Peak: cycle 1 sec. ON & 3 sec OFF. Intermittente: ciclo 20 sec. ON & 3 sec. OFF - Picco: ciclo 1 sec. ON & 3 sec OFF  
Max torque / Coppia max: 550 Nm



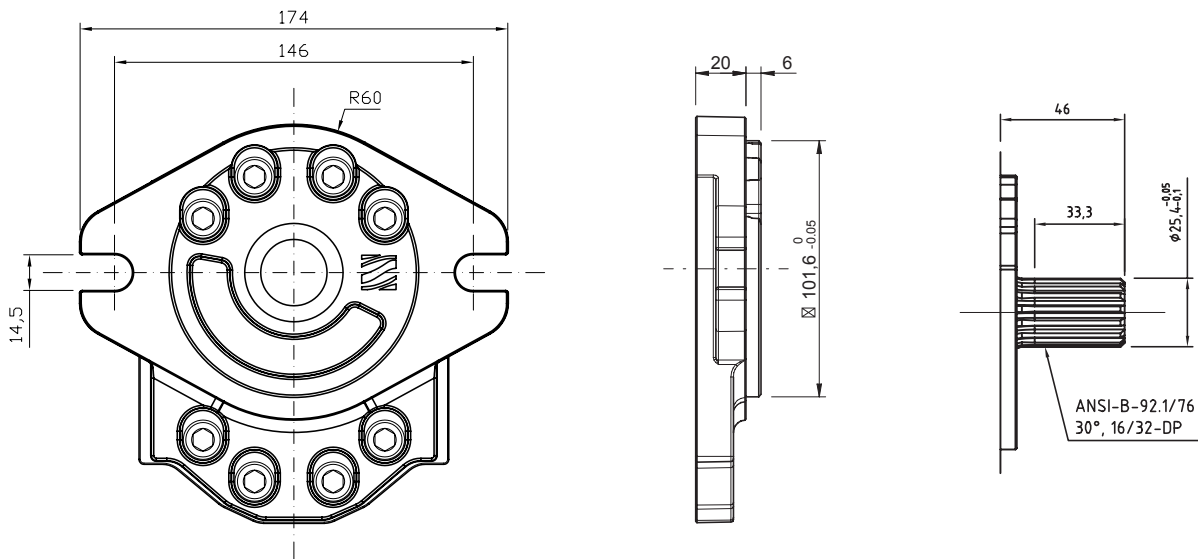

**GR55 - TYPE / TIPO SAEB-T15**

Type Tipo	CC	L/min	Dimensions A Dimensioni A	Dimensions B Dimensioni B (**)	Continuous Pressure Pressione continua	Intermittent Pressure Pressione intermittente (*)	Peak pressure Picco pressione (*)	Noise level Livello rumore
50	50,5	72,7	179,5	81,50	275	280	300	57
63	63,5	91,4	188,5	86,00	249	260	280	57
75	75,0	108,1	196,5	90,00	229	250	270	57
90	90,9	130,9	207,5	95,50	178	240	260	57

Max torque / Coppia max: 700 Nm

\* Intermittent: cycle 20 sec. ON & 3 sec. OFF - Peak: cycle 1 sec. ON & 3 sec OFF. Intermittente: ciclo 20 sec. ON & 3 sec. OFF - Picco: ciclo 1 sec. ON & 3 sec OFF

\*\* Ask SETTIMA the dimensional drawings for "OE" suction port

**GR55 INLET OUTLET PORTS / PORTE DI ASPIRAZIONE E MANDATA - Type OE / Tipo OE**

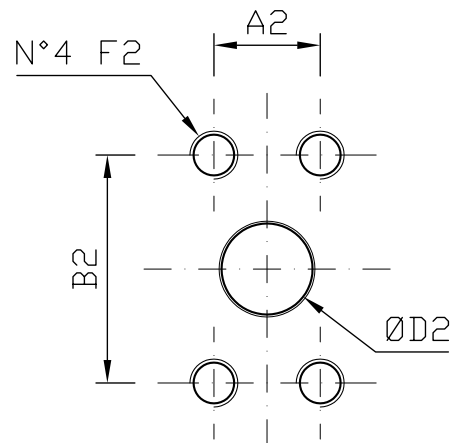
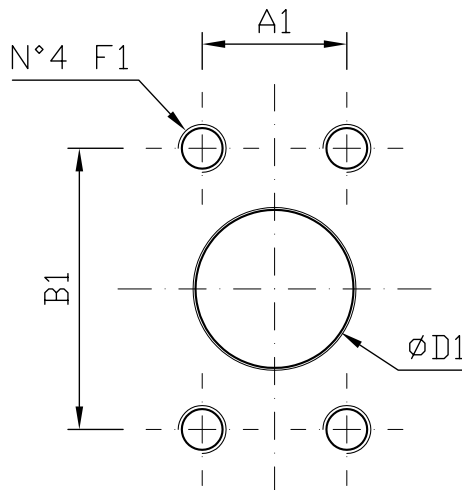

Type port	INLET		
	"O"	"OE"	
Size port	SAE-3000 1" ¼	SAE-3000 1" ¼ only for 50cc	SAE-3000 1" ½
A1	30,20	30,20	35,70
B1	58,70	58,70	69,85
ØD1	33,00	33,00	38,00
F1	M10x20	M10x18	M10x18

Type port	OUTLET	
	"O"	"OE"
Size port	SAE-3000 ¾"	SAE-3000 1"
A2	22,20	26,20
B2	47,60	52,40
ØD2	19,00	25,00
F2	M10X18	M10X18

## GR72 - Dimensional drawings / Disegni dimensionali

### GR72 SHAFT AND FLANGE TYPE AND DIMENSIONS / TIPO ALBERO E FLANGE E DIMENSIONI

#### Group 4 pumps / Pompe gruppo 4

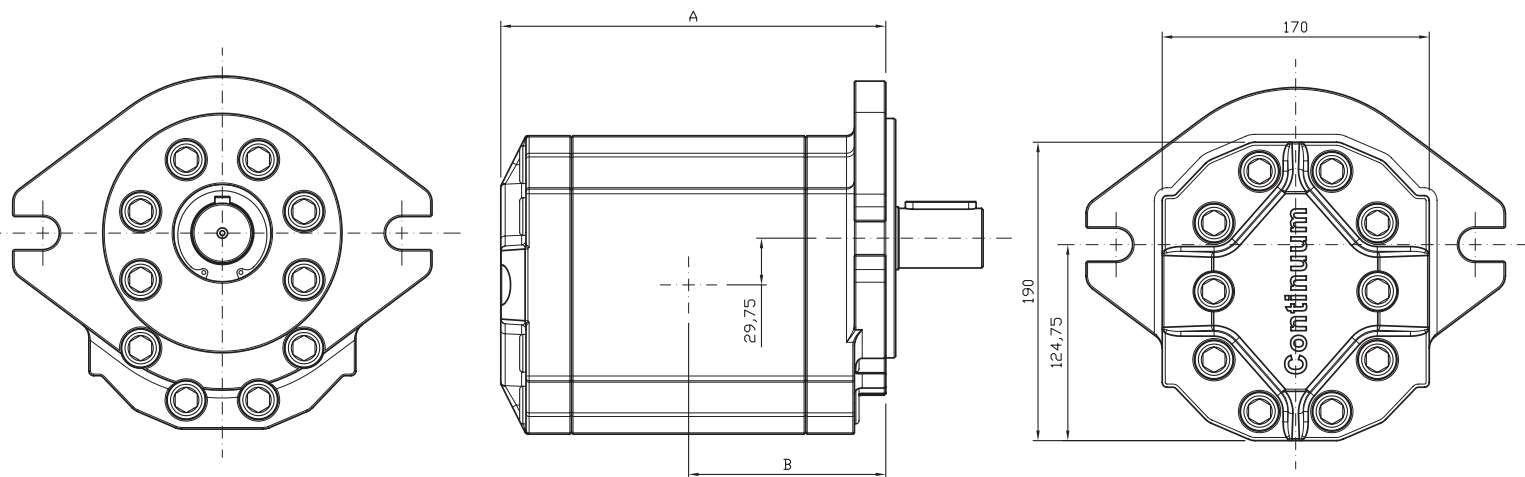

#### Available flanges and shafts / Flange ed alberi disponibili

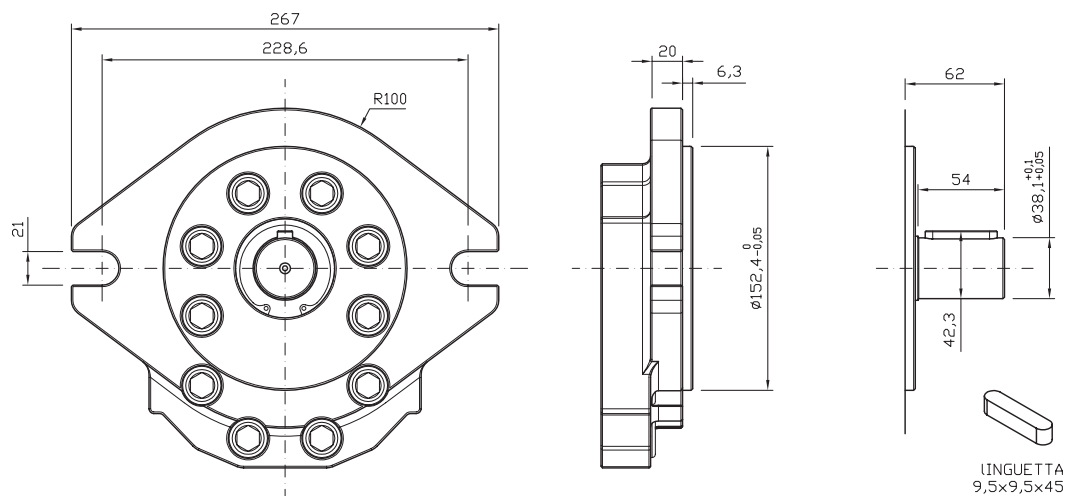

#### GR72 - TYPE / TIPO SAED-AC

Type Tipo	CC	L/min	Dimensions A Dimensioni A	Dimensions B Dimensioni B	Continuous Pressure Pressione continua	Intermittent Pressure Pressione intermittente (*)	Peak pressure Picco pressione (*)	Noise level Livello rumore
94	94,1	136	245,0	125,65	240	250	260	57
101	101,4	147	248,0	127,05	230	240	250	57
125	125,5	181	258,0	132,15	220	220	230	57
150	150,9	218	268,5	137,40	200	210	220	57
175	175,0	253	278,5	142,40	180	190	200	57
200	200,4	290	289,0	147,65	160	170	180	57

Max torque / Coppia max: 1000 Nm

\* Intermittent: cycle 20 sec. ON & 3 sec. OFF - Peak: cycle 1 sec. ON & 3 sec. OFF. Intermittente: ciclo 20 sec. ON & 3 sec. OFF - Picco: ciclo 1 sec. ON & 3 sec. OFF

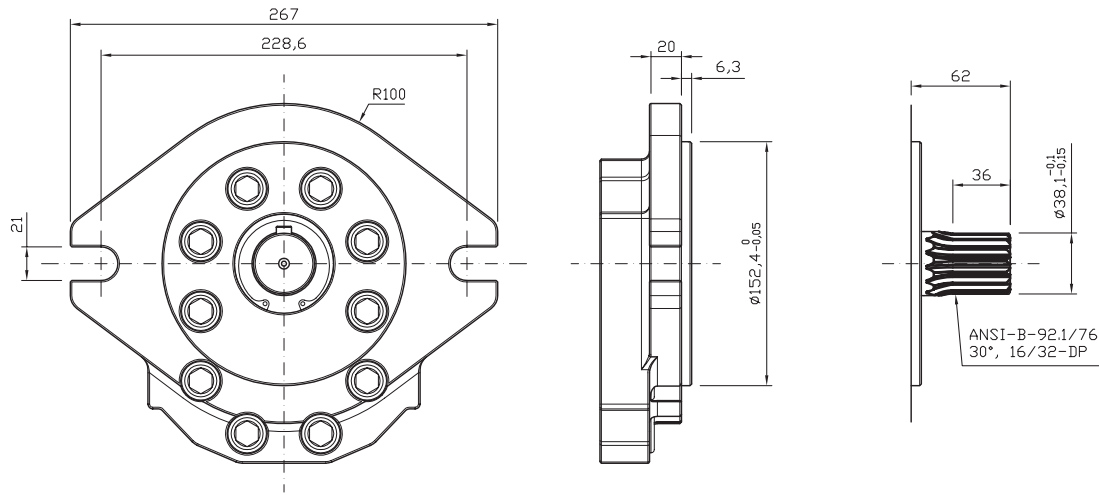

**GR72 - TYPE / TIPO SAED-T23**

Type Tipo	CC	L/min	Dimensions A Dimensioni A	Dimensions B Dimensioni B	Continuous Pressure Pressione continua	Intermittent Pressure Pressione intermittente (*)	Peak pressure Picco pressione (*)	Noise level Livello rumore
94	94,1	136	245,0	125,50	240	250	260	57
101	101,4	147	248,0	127,00	230	240	250	57
125	125,5	181	258,0	132,00	220	220	230	57
150	150,9	218	268,5	137,25	200	210	220	57
175	175,0	253	278,5	142,25	180	190	200	57
200	200,4	290	289,0	147,50	160	170	180	57

Max torque / Coppia max: 1200 Nm

\* Intermittent: cycle 20 sec. ON & 3 sec. OFF - Peak: cycle 1 sec. ON & 3 sec OFF. Intermittente: ciclo 20 sec. ON & 3 sec. OFF - Picco: ciclo 1 sec. ON & 3 sec OFF

**GR72 INLET OUTLET PORTS / PORTE DI ASPIRAZIONE E MANDATA - Type ME / Tipo ME**

**SAE 3000 2" 1/2**

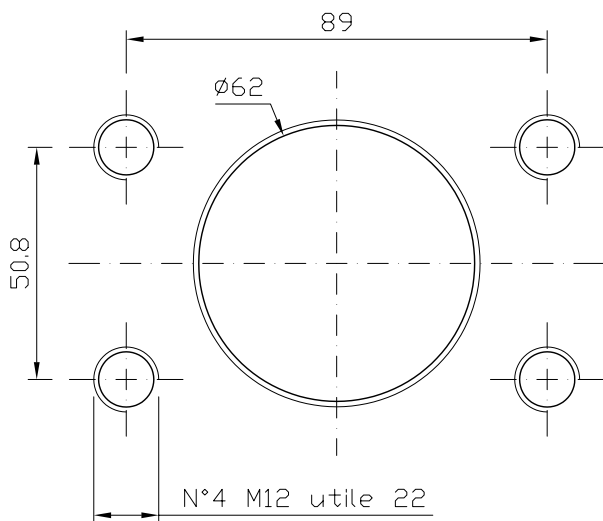

**Inlet**

**SAE 6000 1" 1/2**

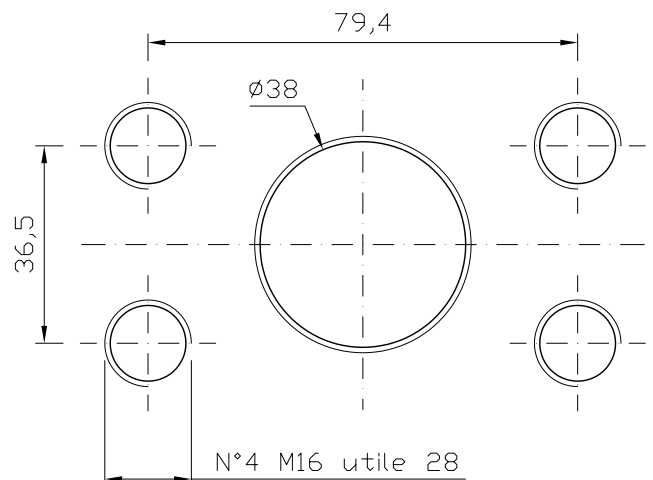

**Outlet**

# Flow performances @ 46 cSt

**GR28 1-C3 / 1L-GL54 / 1L-G54**

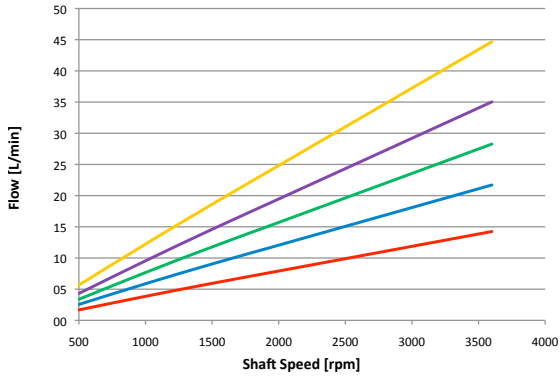

**GR28 1P-C2**

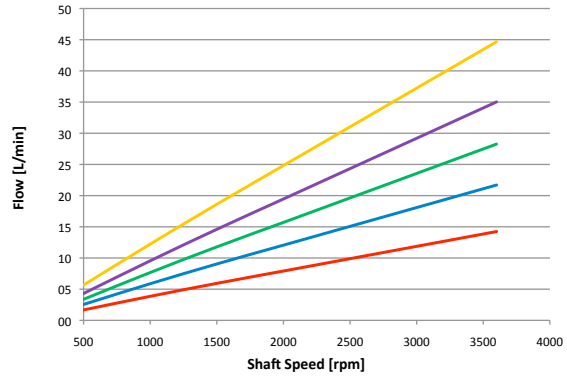

**GR28 1K-G54 / 1K-GL54**

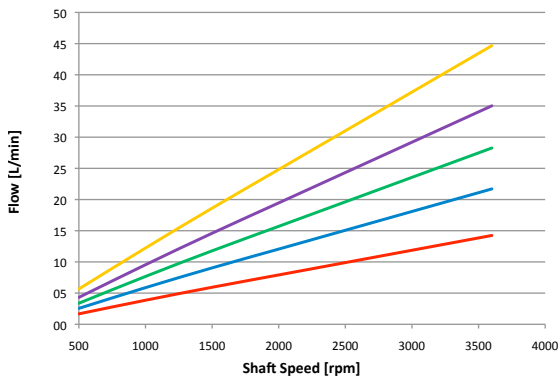

**GR28 SAEA-AC**

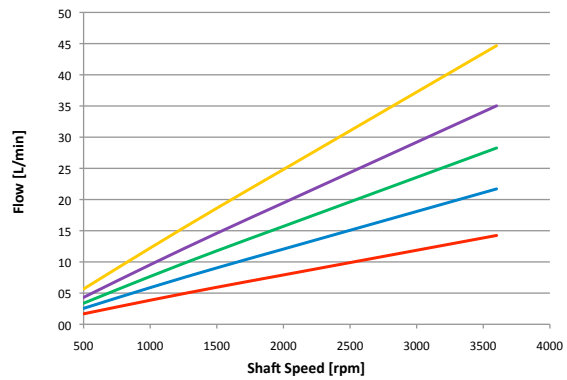

**GR33**

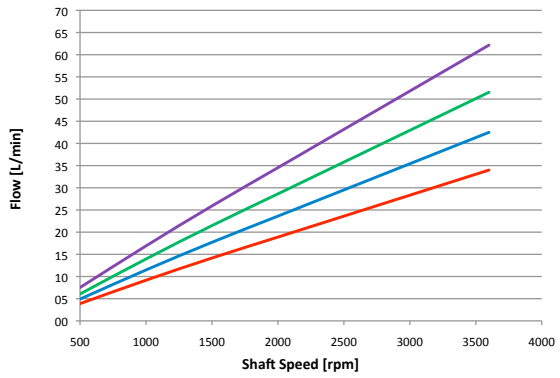

**GR38**

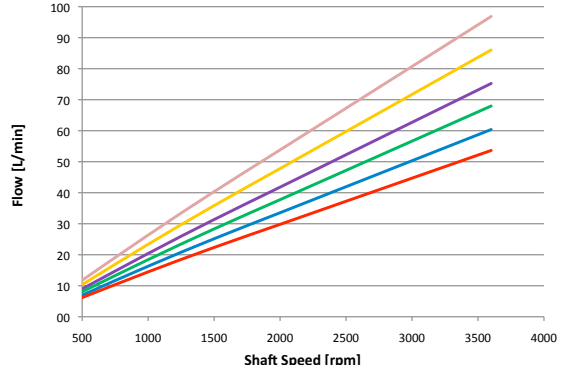

**GR38 SAEA-T9**

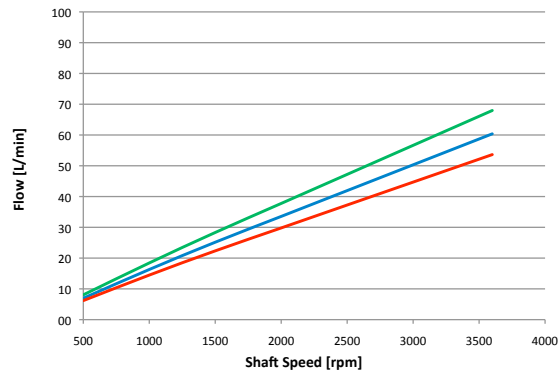

**GR47**

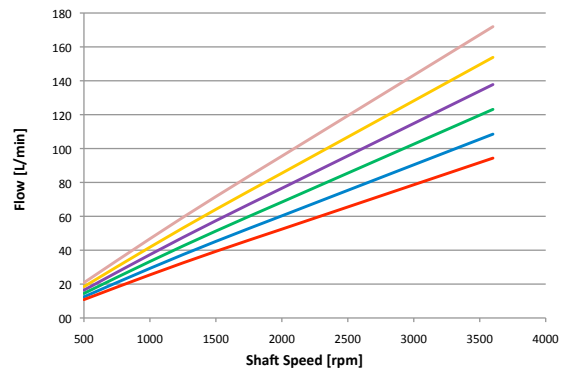

# Flow performances @ 46 cSt

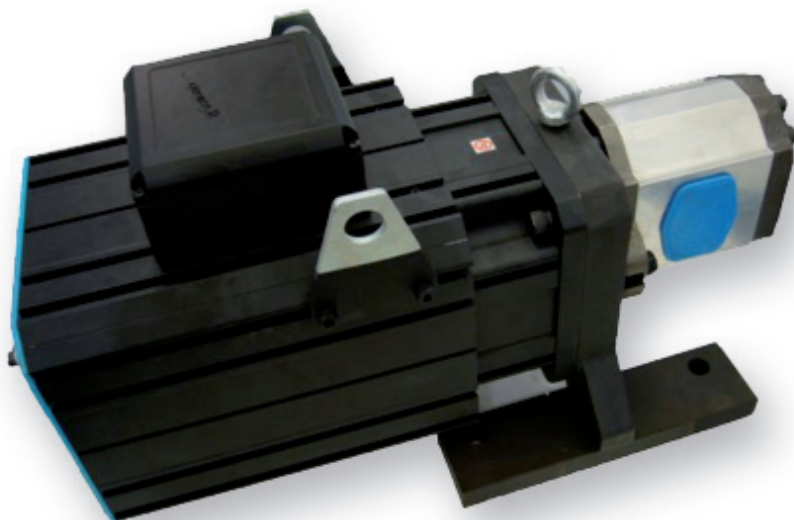
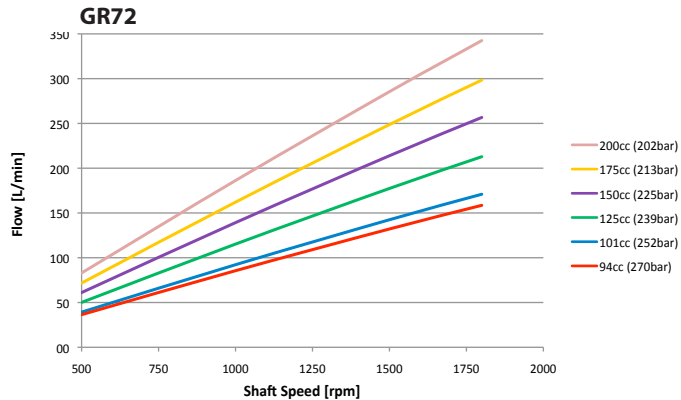
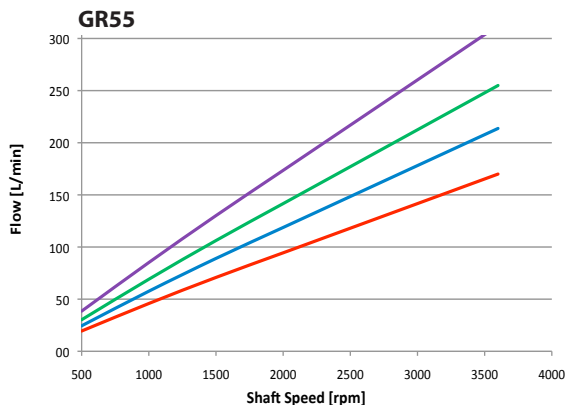

Servo Continuum® pump - *Servopompa Continuum®*

# Power-torque performances @ 46 cSt

**GR28 4 CC**

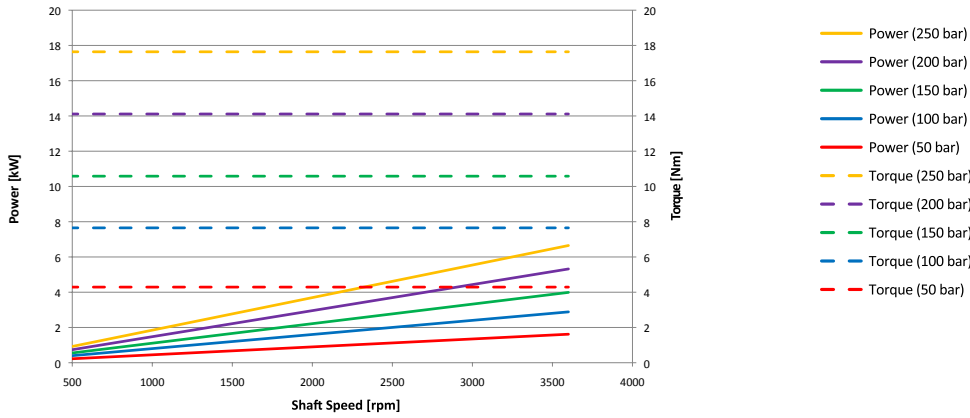

**GR28 6 CC**

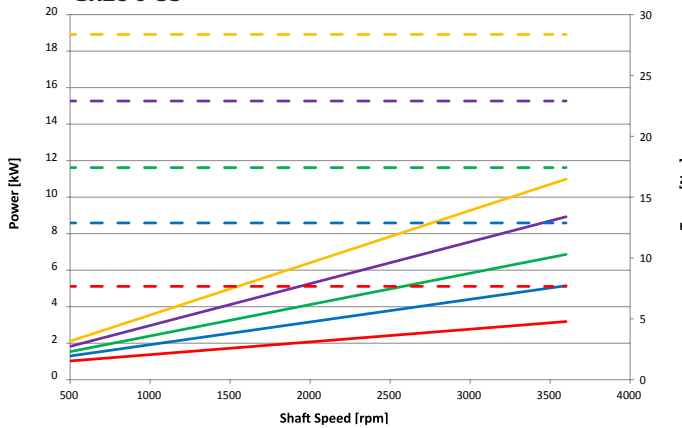

**GR28 8 CC**

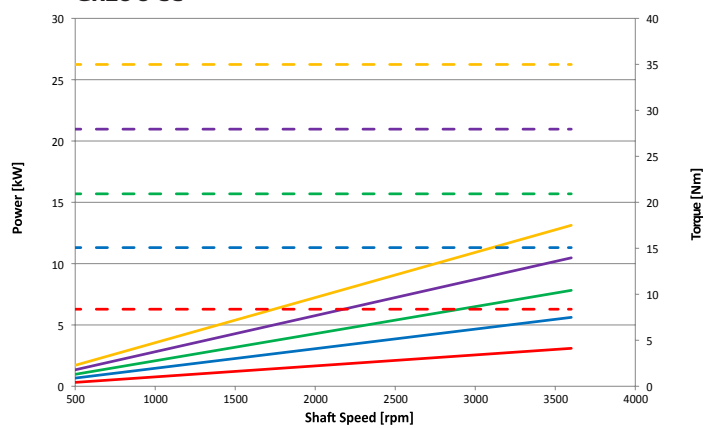

**GR28 10 CC**

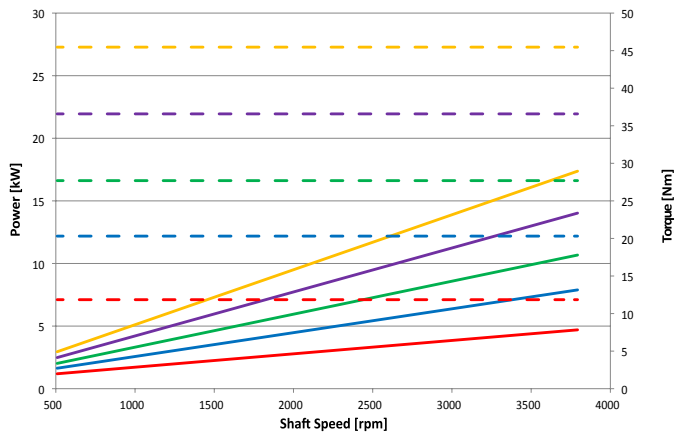

**GR28 13 CC**

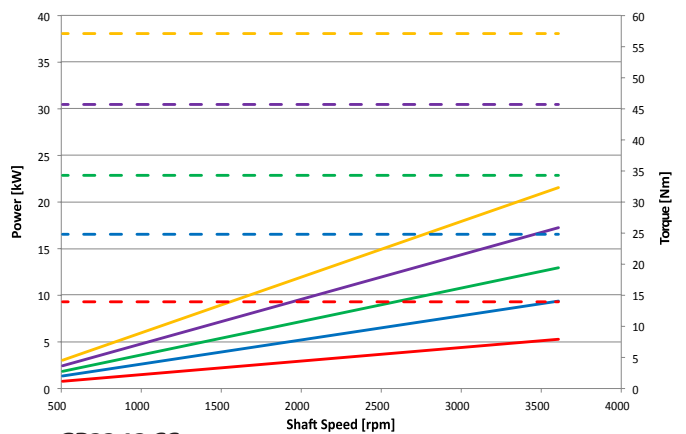

**GR33 10 CC**

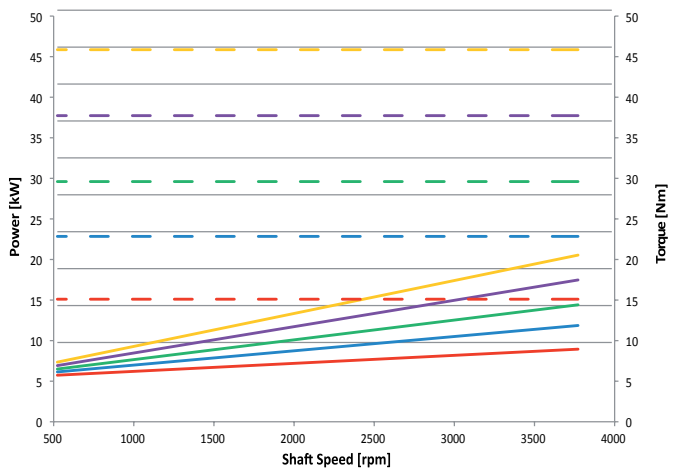

**GR33 13 CC**

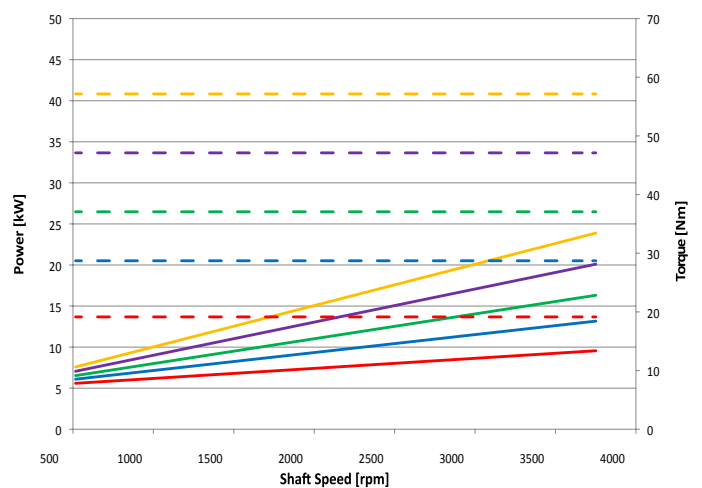

# Power-torque performances @ 46 cSt

**GR33 15 CC**

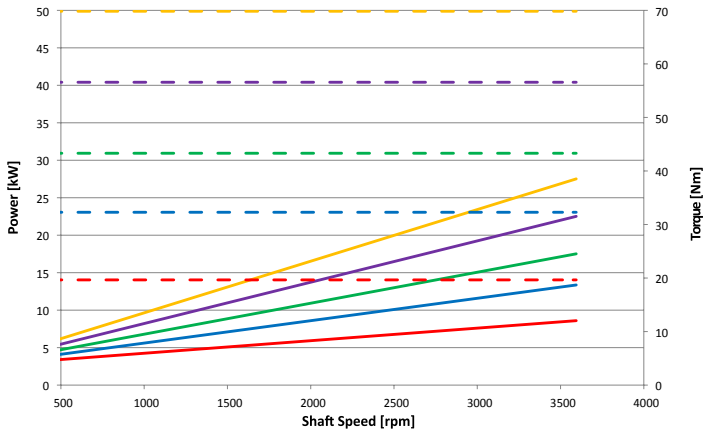

**GR33 18 CC**

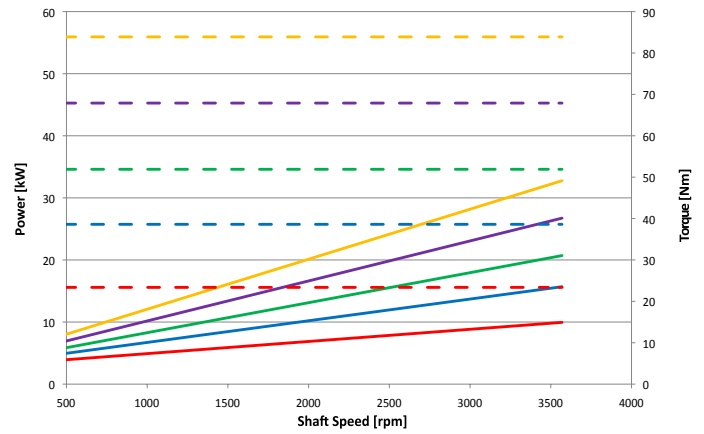

**GR38 16 CC**

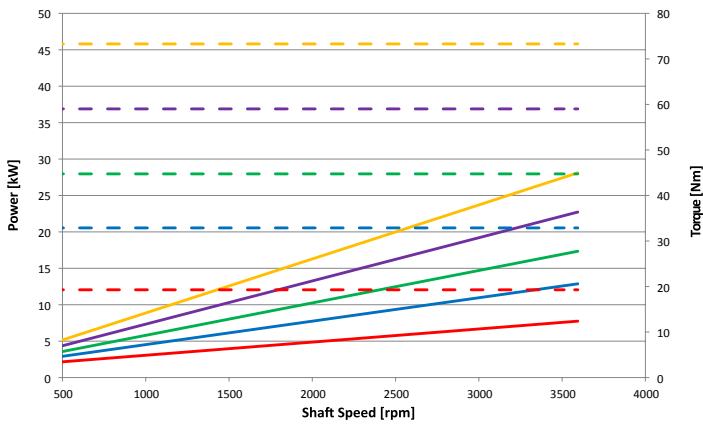

**GR38 18 CC**

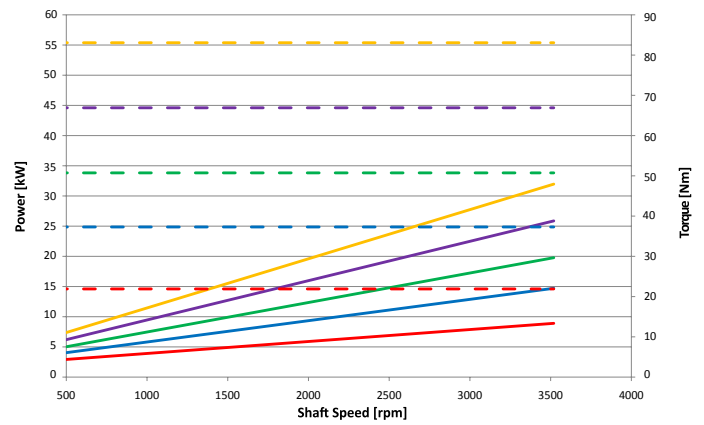

**GR38 20 CC**

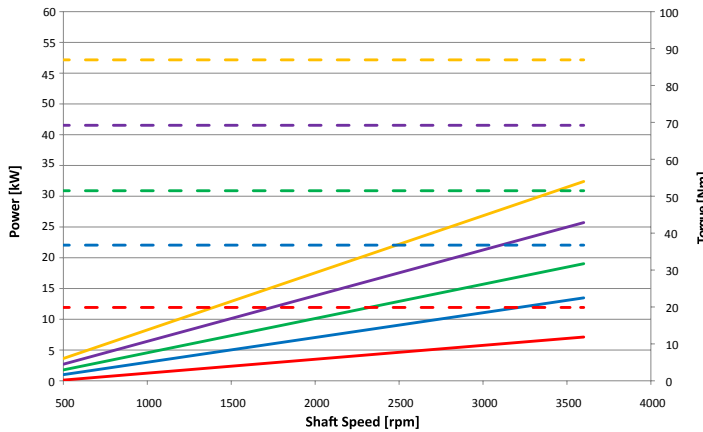

**GR38 22 CC**

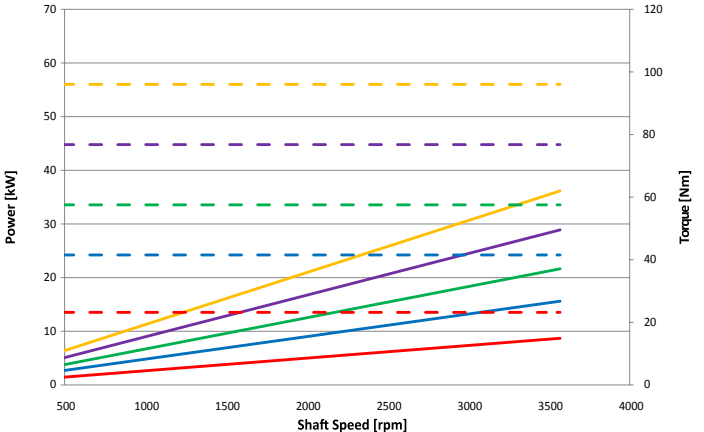

**GR38 25 CC**

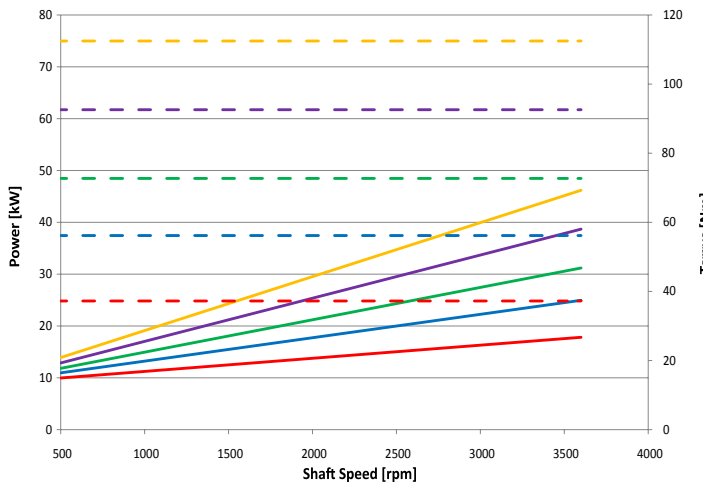

**GR38 28 CC**

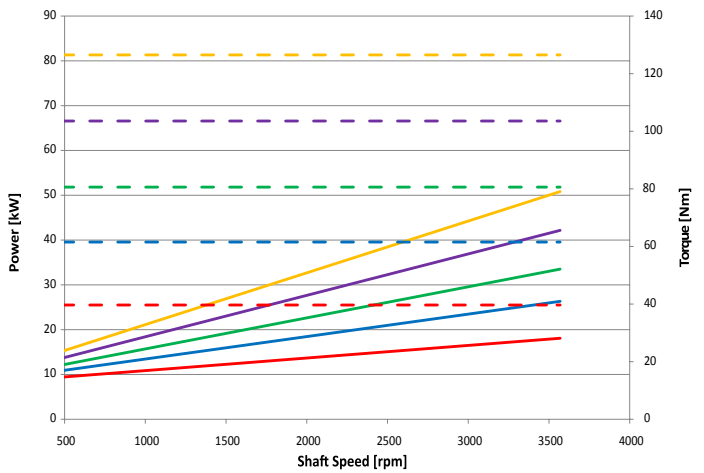

# Power-torque performances @ 46 cSt

**GR47 28 CC**

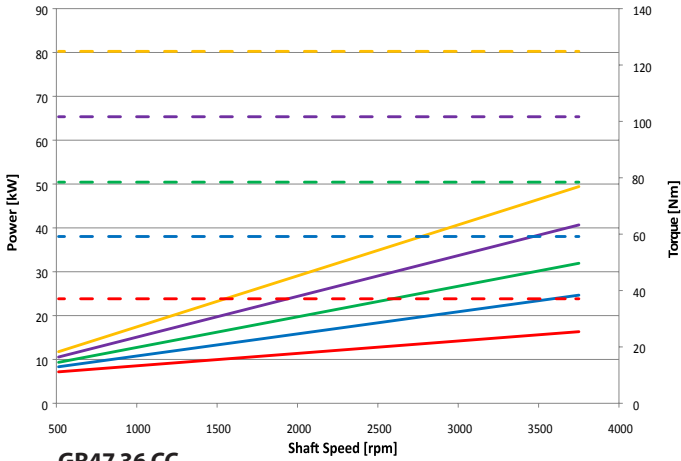

**GR47 32 CC**

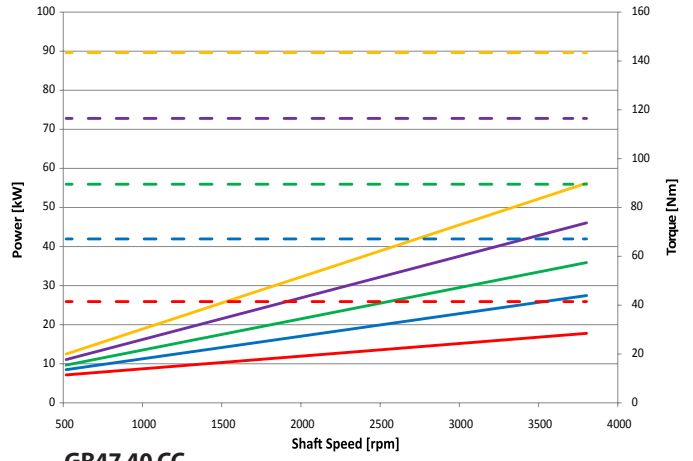

**GR47 36 CC**

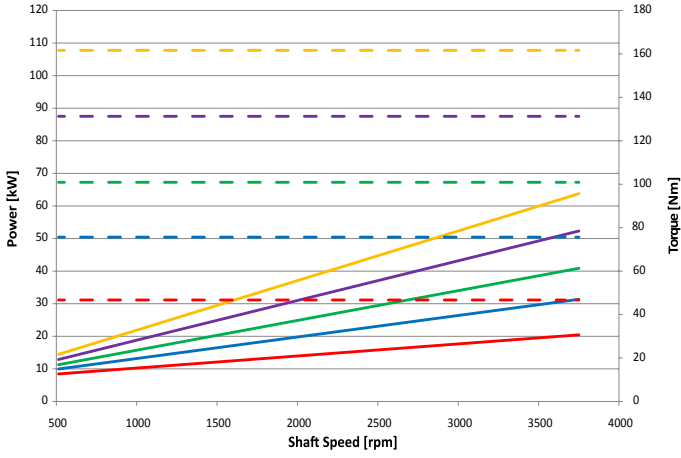

**GR47 40 CC**

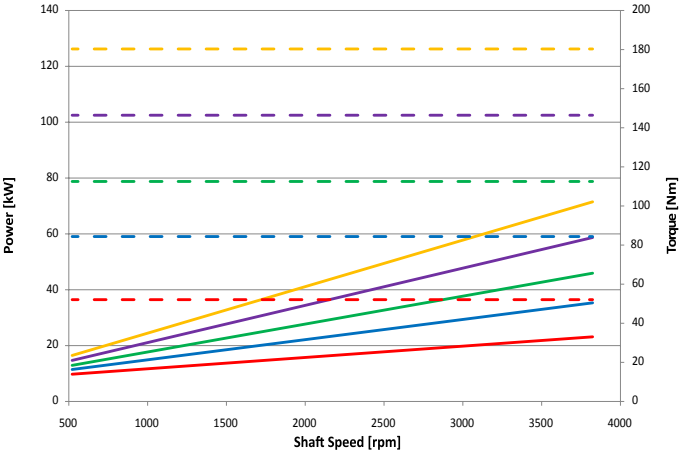

**GR47 45 CC**

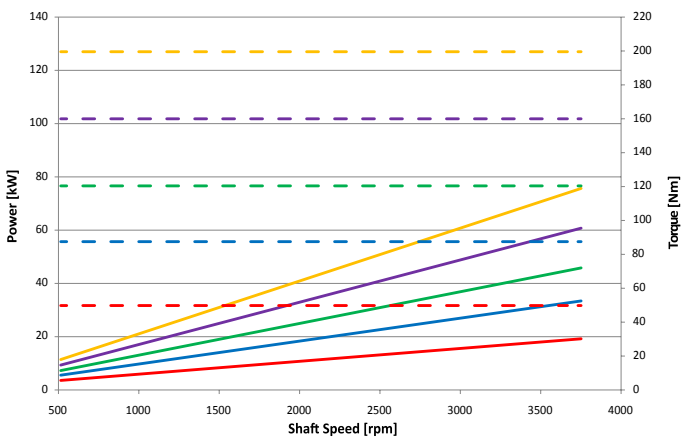

**GR47 50 CC**

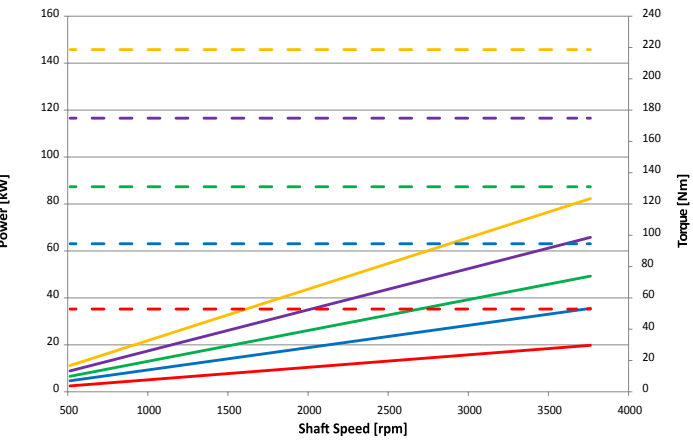

**GR55 50 CC**

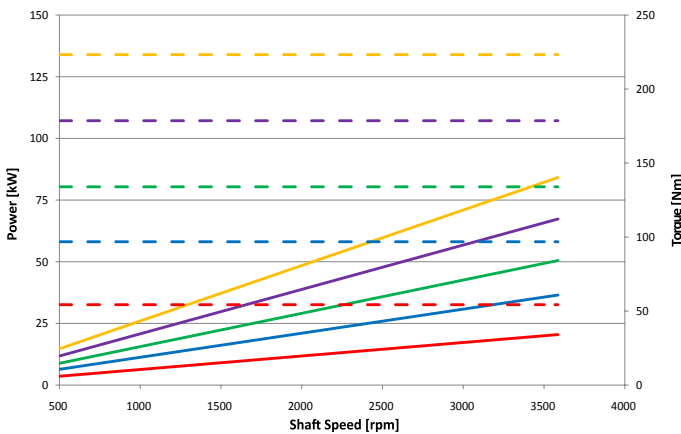

**GR55 63 CC**

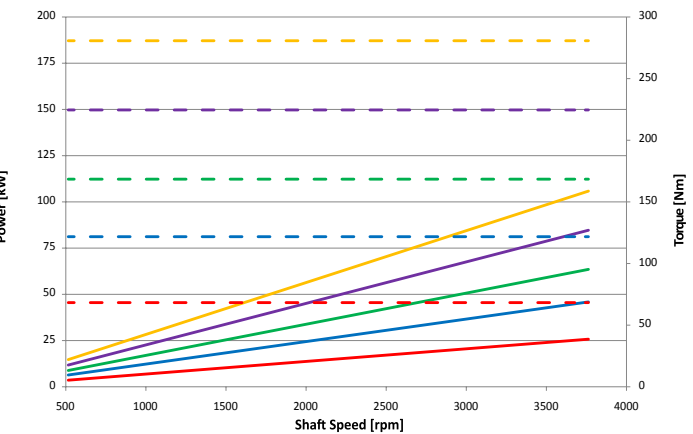



# Power-torque performances @ 46 cSt

**GR55 75**

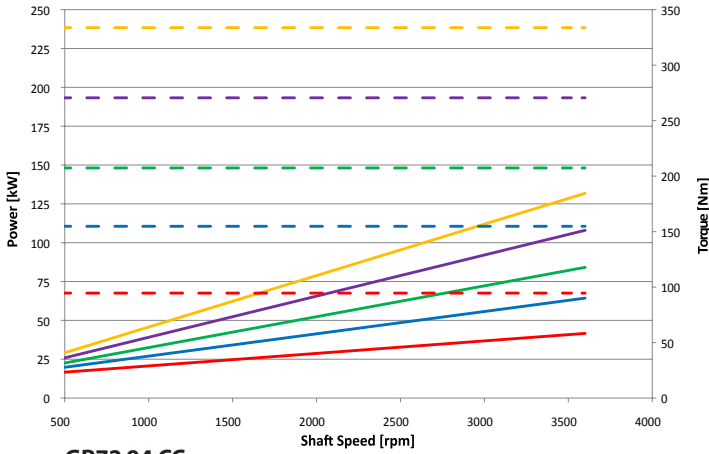

**GR55 90 CC**

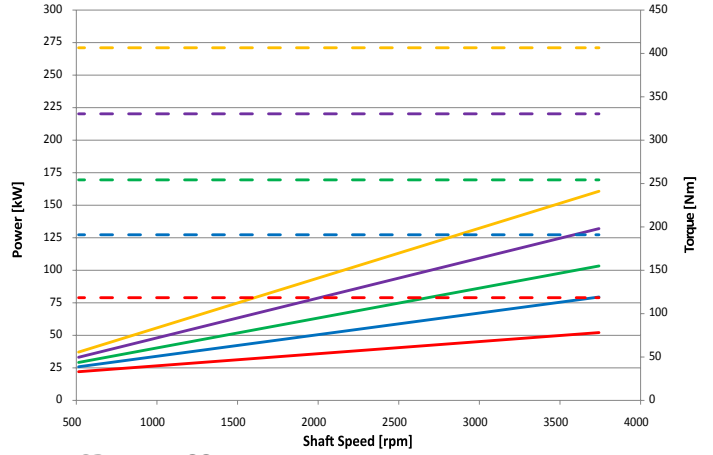

**GR72 94 CC**

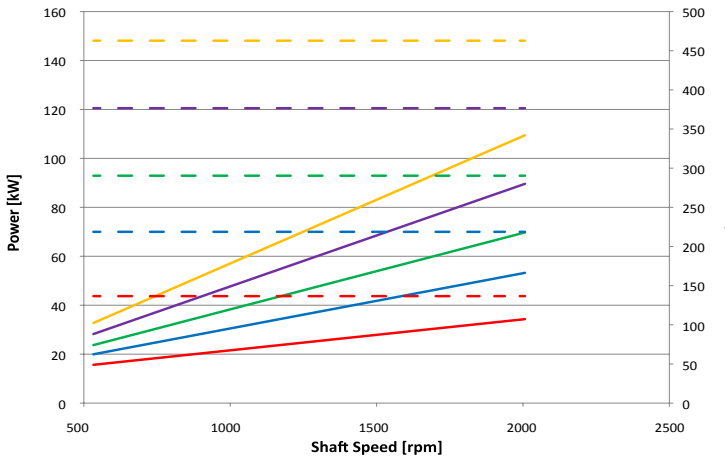

**GR72 101 CC**

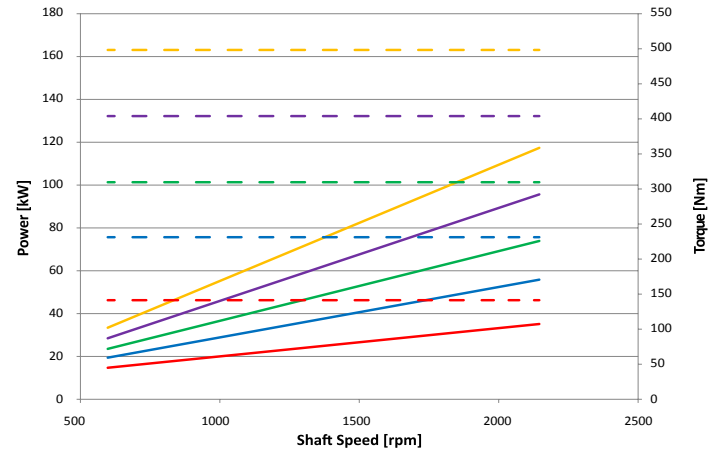

**GR72 125 CC**

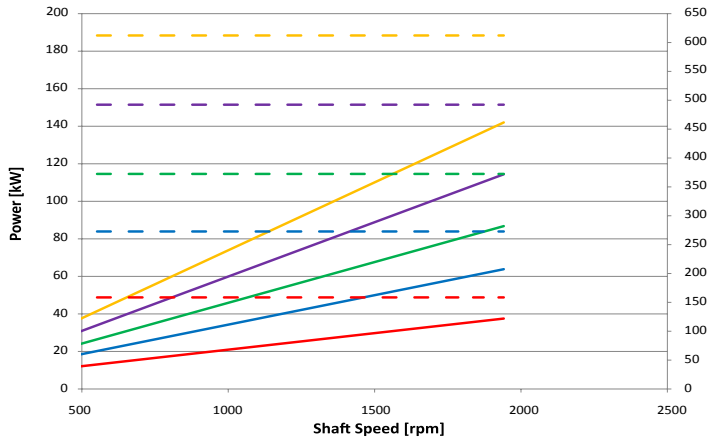

**GR72 150 CC**

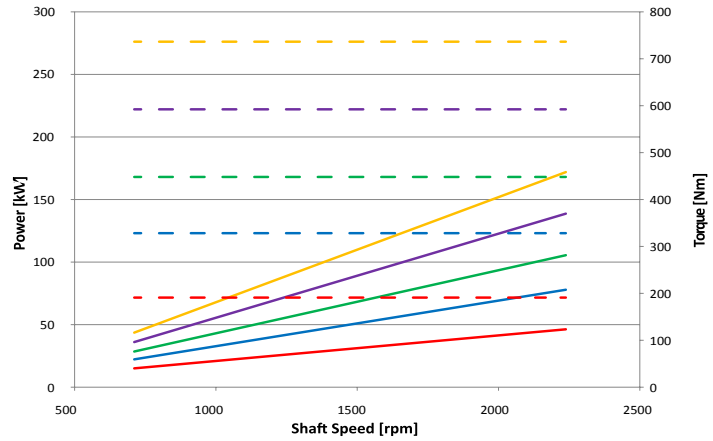

**GR72 175 CC**

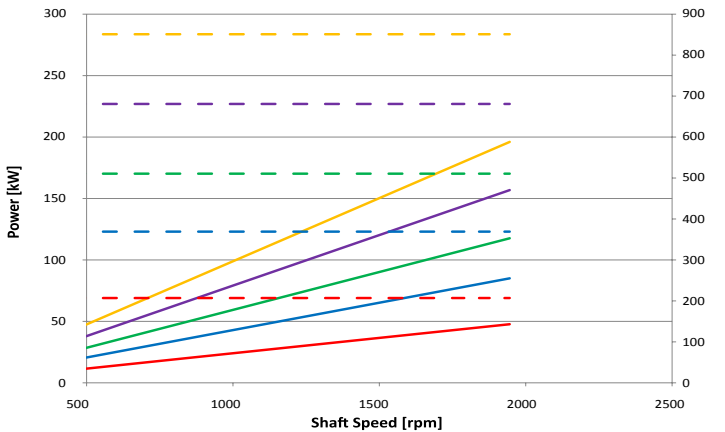

**GR72 200 CC**

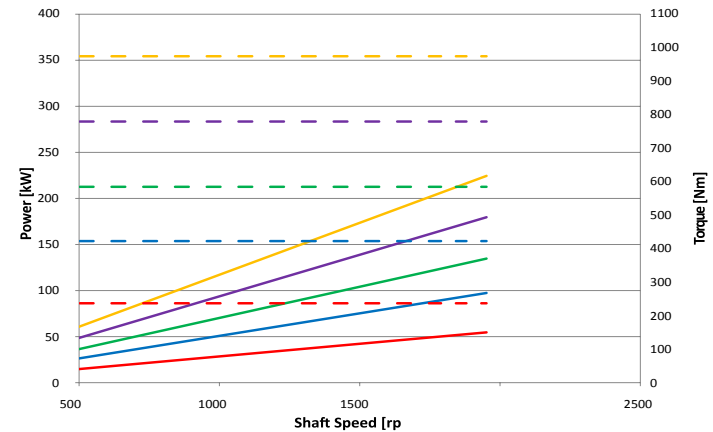

## Tandem & multiple pumps / Pompe doppie e multiple

**Continuum**® pumps are suitable for multiple setups, whereby the drive shaft of the first pump is extended to a second and even a third **Continuum**® pump. Each pump is connected to another by means of coupling. Each pump has its own suction port. Basically the technical specifications of single pumps apply also to multiple setups\*\*. The maximum speed is determined by the highest pump speed rate in use. In case of multiple setup configurations, it is recommended to use the largest displacement for the first pump. The front pump may be equipped with different types of flange and shaft.

### Ordering code / Codice ordine

#### Multiple setups / Pompe multiple

Type Tipo	Class Classe	Displacement Cilindrata	Flange & shaft Flangia & albero	Ports Porte	Type <sup>2nd</sup> stage Tipo 2° stadio	Displacement <sup>2nd</sup> stage Cilindrata 2° stadio	Ports Porte	Shaft seal Guarnizione albero	Rotation Rotazione	
DG28	2V	004-006-008-010-013	F1AC3	G	GR28	004-006-008-010-013	G	Standard NBR (none)	Standard DX (none) 	
DG33	2V	010-013-015-018	F2AC4	G-M-	GR28					
				Q-U	GR33	010-013-015-018				
DG38	2V	016-018-020-022-025-028	F2AC4	G-M-	GR38	016-018-020-022-025-028	Q-U			
					Q-U	GR28	004-006-008-010-013			G
						GR33	010-013-015-018			G-M-
DG47	2V	028-032-036-040-045-050	F3AC9 FSAEBAT13	O-U	GR38	016-018-020-022-025-028	Q-U			
					GR28	004-006-008-010-013	G			
					GR33	010-013-015-018	G-M-			
					GR47	028-032-036-040-045-050	O-U			
DG55	2V	050-063-075-090	FSAEBAT15	O-OE	GR28	004-006-008-010-013	G			
					GR33	010-013-015-018	G-M-			
					GR38	016-018-020-022-025-028	Q-U			
					GR47	028-032-036-040-045-050	O-U			
					GR55	050-063-075-090	O-OE			
DG72	2V	094-101-125-150-175-200-220	FSAEBAT23	ME	GR47	028-032-036-040-045-050	O-U			
					GR55	050-063-075-090	O-OE			
					GR72	094-101-125-150-175-200	ME			

\* Please contact Settima for SX counter clockwise optional rotation. *Contattare Settima per rotazione SX opzionale.*

\*\* The minimum operating pressure recommended for the second stage is 30 bar. In case of lower pressure, please, contact Settima. *Minima pressione di funzionamento consigliata per il secondo stadio 30 bar, al di sotto, contattare Settima.*

## GR28 - Group 1 tandem pumps

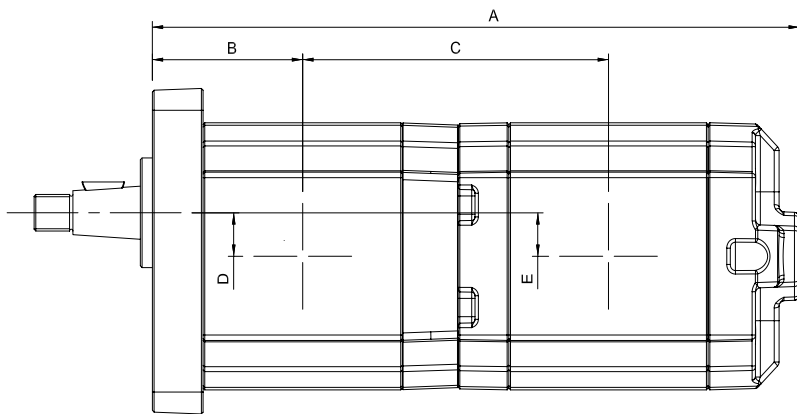

GR28 + GR28		2°				
		4	6	8	10	13
4	A	191,50	-	-	-	-
	B	44,50	-	-	-	-
	C	90,50	-	-	-	-
	D	11,90	-	-	-	-
	E	11,90	-	-	-	-
6	A	197,00	202,50	-	-	-
	B	47,25	47,25	-	-	-
	C	93,25	96,00	-	-	-
	D	11,90	11,90	-	-	-
	E	11,90	11,90	-	-	-
8	A	202,00	207,50	212,50	-	-
	B	49,75	49,75	49,75	-	-
	C	95,75	98,50	101,00	-	-
	D	11,90	11,90	11,90	-	-
	E	11,90	11,90	11,90	-	-
10	A	207,00	212,50	217,50	222,50	-
	B	52,25	52,25	52,25	52,25	-
	C	98,25	101,00	103,50	106,00	-
	D	11,90	11,90	11,90	11,90	-
	E	11,90	11,90	11,90	11,90	-
13	A	214,00	219,50	224,50	229,50	236,50
	B	55,70	55,70	55,70	55,70	55,70
	C	101,75	104,50	107,00	109,50	113,00
	D	11,90	11,90	11,90	11,90	11,90
	E	11,90	11,90	11,90	11,90	11,90

### Available flanges and shafts for GR28 Flange ed alberi disponibili per GR28

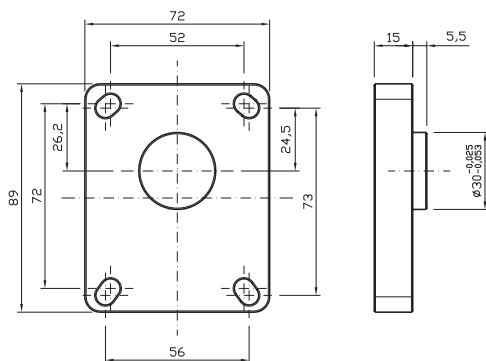

Type flange 1C3 / Flangia tipo 1 C3

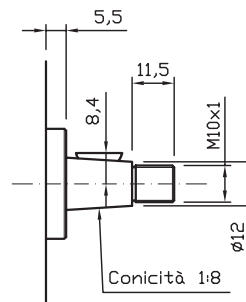

Type shaft 1C3 / Albero tipo 1C3  
Max torque / Coppia max: 100 Nm

## GR33 & GR38 - Groups 2 tandem pumps

### GR33

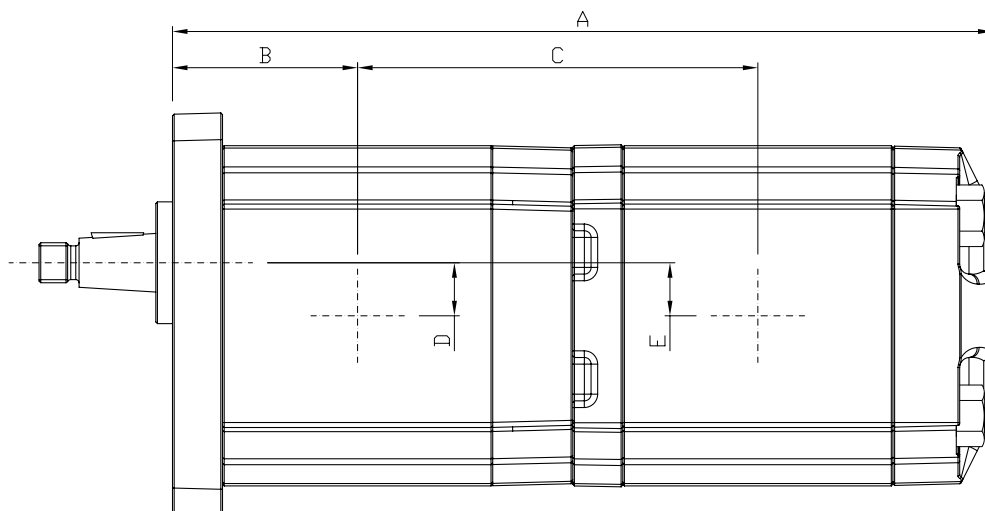

GR33 + GR28			2°				
			4	6	8	10	13
1°	10	A	216,50	222,00	227,00	232,00	239,00
		B	53,75	53,75	53,75	53,75	53,75
		C	16,25	109,00	111,50	114,00	117,50
		D	13,75	13,75	13,75	13,75	13,75
		E	11,90	11,90	11,90	11,90	11,90
	13	A	221,4	226,90	231,90	236,90	243,90
		B	56,20	56,20	56,20	56,20	56,20
		C	108,70	111,45	113,95	116,45	119,95
		D	13,75	13,75	13,75	13,75	13,75
		E	11,90	11,90	11,90	11,90	11,90
	15	A	226,40	231,90	236,90	241,90	248,90
		B	58,70	58,70	58,70	58,70	58,70
		C	111,20	113,95	116,45	118,95	122,45
		D	13,75	13,75	13,75	13,75	13,75
		E	11,90	11,90	11,90	11,90	11,90
	18	A	232,2	237,70	242,70	247,70	254,70
		B	61,60	61,60	61,60	61,60	61,60
		C	114,10	116,85	119,35	121,85	125,35
		D	13,75	13,75	13,75	13,75	13,75
		E	11,90	11,90	11,90	11,90	11,90

GR33 + GR33			2°			
			10	13	15	18
1°	10	A	236,00	-	-	-
		B	53,75	-	-	-
		C	113,50	-	-	-
		D	13,75	-	-	-
		E	13,75	-	-	-

GR33 + GR33		2°				
		10	13	15	18	
	13	A	240,90	245,80	-	-
		B	56,20	56,20	-	-
		C	115,95	118,40	-	-
		D	13,75	13,75	-	-
		E	13,75	13,75	-	-
	15	A	245,90	250,80	255,80	-
		B	58,70	58,70	58,70	-
		C	118,45	120,90	123,40	-
		D	13,75	13,75	13,75	-
		E	13,75	13,75	13,75	-
	18	A	251,70	256,60	261,60	267,40
		B	61,60	61,60	61,60	61,60
		C	121,35	123,80	126,30	129,20
		D	13,75	13,75	13,75	13,75
		E	13,75	13,75	13,75	13,75

**Available flanges and shafts for GR33**  
**Flange ed alberi disponibili per GR33**

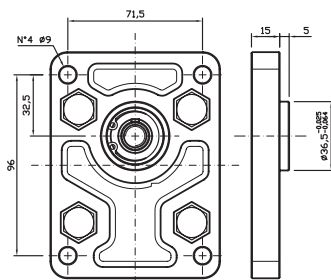

Type flange 2C4  
 Flangia tipo 2C4

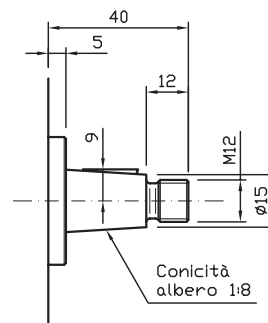

Type shaft 2C4  
 Albero tipo 2C4  
 Max torque / Coppia max: 210 Nm

GR38 + GR28			2°				
			4	6	8	10	13
1°	16	A	191,50	228,50	233,50	238,50	245,50
		B	44,50	55,50	55,50	55,50	55,50
		C	90,50	113,75	116,25	118,75	122,25
		D	11,90	15,90	15,90	15,90	15,90
		E	11,90	11,90	11,90	11,90	11,90
	18	A	226,00	231,50	236,50	241,50	248,50
		B	57,00	57,00	57,00	57,00	57,00
		C	112,50	115,25	117,75	120,25	123,75
		D	15,90	15,90	15,90	15,90	15,90
		E	11,90	11,90	11,90	11,90	11,90
	20	A	229,00	234,50	239,50	244,50	251,50
		B	58,50	58,50	58,50	58,50	58,50
		C	114,00	116,75	119,25	121,75	125,25
		D	15,90	15,90	15,90	15,90	15,90
		E	11,90	11,90	11,90	11,90	11,90
	22	A	232,00	237,50	242,50	247,5	254,50
		B	60,00	60,00	60,00	60,00	60,00
		C	115,50	118,25	120,75	123,25	126,75
		D	15,90	15,90	15,90	15,90	15,90
		E	11,90	11,90	11,90	11,90	11,90
	25	A	236,50	242,00	247,00	252,00	259,00
		B	62,25	62,25	62,25	62,25	62,25
		C	117,75	120,50	123,00	125,50	129,00
		D	15,90	15,90	15,90	15,90	15,90
		E	11,90	11,90	11,90	11,90	11,90
28	A	241,00	246,50	251,50	256,50	263,50	
	B	64,50	64,50	64,50	64,50	64,50	
	C	120,00	122,75	125,25	127,75	131,25	
	D	15,90	15,90	15,90	15,90	15,90	
	E	11,90	11,90	11,90	11,90	11,90	

GR38 + GR33			2°			
			10	13	15	18
1°	16	A	242,50	247,40	252,40	258,20
		B	55,50	55,50	55,50	55,50
		C	118,25	120,70	123,20	126,10
		D	15,90	15,90	15,90	15,90
		E	13,75	13,75	13,75	13,75

GR38 + GR33			2°			
			10	13	15	18
	18	A	245,50	250,40	255,40	261,20
		B	57,00	57,00	57,00	57,00
		C	119,75	122,20	124,70	127,60
		D	15,90	15,90	15,90	15,90
		E	13,75	13,75	13,75	13,75
	20	A	248,50	253,40	258,40	264,20
		B	58,50	58,50	58,50	58,50
		C	121,25	123,70	126,20	129,10
		D	15,90	15,90	15,90	15,90
		E	13,75	13,75	13,75	13,75
	22	A	251,50	256,40	261,40	267,20
		B	60,00	60,00	60,00	60,00
		C	122,75	125,20	127,70	130,60
		D	15,90	15,90	15,90	15,90
		E	13,75	13,75	13,75	13,75
	25	A	2560	260,90	265,90	271,70
		B	62,25	62,25	62,25	62,25
		C	1250	127,45	129,95	132,85
		D	15,90	15,90	15,90	15,90
		E	13,75	13,75	13,75	13,75
28	A	260,50	265,4	270,40	276,20	
	B	64,50	64,50	64,50	64,50	
	C	127,25	129,70	132,20	135,1 0	
	D	15,90	15,90	15,90	15,90	
	E	13,75	13,75	13,75	13,75	

GR38 + GR38			2°					
			16	18	20	22	25	28
1°	16	A	246,00	-	-	-	-	-
		B	55,50	-	-	-	-	-
		C	120,00	-	-	-	-	-
		D	15,90	-	-	-	-	-
		E	15,90	-	-	-	-	-
	18	A	249,00	252,00	-	-	-	-
		B	57,00	57,00	-	-	-	-
		C	121,50	123,00	-	-	-	-
		D	15,90	15,90	-	-	-	-
		E	15,90	15,90	-	-	-	-

GR38 + GR38			2°					
			16	18	20	22	25	28
1°	20	A	252,00	255,00	258,00	-	-	-
		B	58,50	58,50	58,50	-	-	-
		C	123,00	124,50	126,00	-	-	-
		D	15,90	15,90	15,90	-	-	-
		E	15,90	15,90	15,90	-	-	-
	22	A	255,00	258,00	261,00	264,00	-	-
		B	60,00	60,00	60,00	60,00	-	-
		C	124,50	126,00	127,50	129,00	-	-
		D	15,90	15,90	15,90	15,90	-	-
		E	15,90	15,90	15,90	15,90	-	-
	25	A	259,50	262,50	265,50	268,50	273,00	-
		B	62,25	62,25	62,25	62,25	62,25	-
		C	126,75	128,25	129,75	131,25	133,50	-
		D	15,90	15,90	15,90	15,90	15,90	-
		E	15,90	15,90	15,90	15,90	15,90	-
	28	A	264,00	267,00	270,00	273,00	277,50	282,00
		B	64,50	64,50	64,50	64,50	64,50	64,50
		C	129,00	130,50	132,00	133,50	135,75	138,00
		D	15,90	15,90	15,90	15,90	15,90	15,90
		E	15,90	15,90	15,90	15,90	15,90	15,90

**Available flanges and shafts for GR38**  
**Flange ed alberi disponibili per GR38**

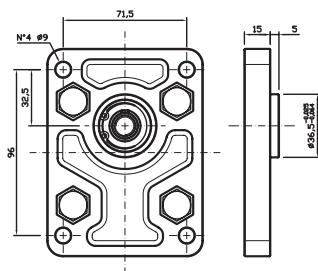

Type flange 2C4  
 Flangia tipo 2C4

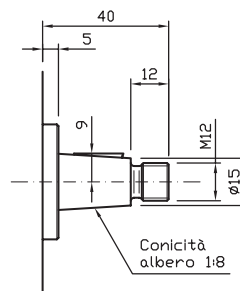

Type shaft 2C4  
 Albero tipo 2C4  
 Max torque / Coppia max: 210 Nm



## GR47 - Group 3 tandem pumps

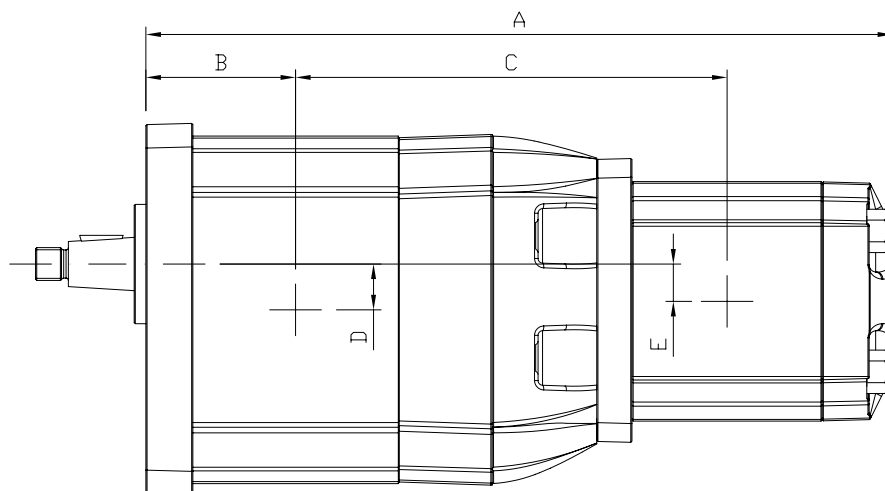

GR47 + GR28		2°					
		4	6	8	10	13	
1°	28	A	292,00	297,50	302,50	307,50	314,40
		B	67,50	67,50	67,50	67,50	67,50
		C	168,00	170,75	173,25	175,75	179,25
		D	19,50	19,50	19,50	19,50	19,50
		E	11,90	11,90	11,90	11,90	11,90
	32	A	296,00	301,50	306,50	311,50	318,40
		B	69,50	69,50	69,50	69,50	69,50
		C	170,00	172,75	175,25	177,75	181,25
		D	19,50	19,50	19,50	19,50	19,50
		E	11,90	11,90	11,90	11,90	11,90
	36	A	300,00	305,50	310,50	315,50	322,40
		B	71,50	71,50	71,50	71,50	71,50
		C	136,00	138,75	141,25	143,75	147,20
		D	19,50	19,50	19,50	19,50	19,50
		E	11,90	11,90	11,90	11,90	11,90
	40	A	304,00	309,50	314,50	319,50	326,40
		B	73,50	73,50	73,50	73,50	73,50
		C	174,00	176,75	179,25	181,75	185,25
		D	19,50	19,50	19,50	19,50	19,50
		E	11,90	11,90	11,90	11,90	11,90
45	A	308,50	314,00	319,00	324,00	330,90	
	B	75,75	75,75	75,75	75,75	75,75	
	C	140,25	143,00	145,50	148,00	151,45	
	D	19,50	19,50	19,50	19,50	19,50	
	E	11,90	11,90	11,90	11,90	11,90	
50	A	313,50	319,00	324,00	329,00	335,90	
	B	78,25	78,25	78,25	78,25	78,25	
	C	178,75	181,50	184,00	186,50	190,00	
	D	19,50	19,50	19,50	19,50	19,50	
	E	11,90	11,90	11,90	11,90	11,90	

GR47 + GR33			2°			
			10	13	15	18
1°	28	A	322,00	326,90	331,90	337,70
		B	67,50	67,50	67,50	67,50
		C	185,25	188,20	190,70	193,60
		D	19,50	19,50	19,50	19,50
		E	13,75	13,75	13,75	13,75
	32	A	326,00	330,90	335,90	341,70
		B	69,50	69,50	69,50	69,50
		C	187,25	190,20	192,70	195,60
		D	19,50	19,50	19,50	19,50
		E	13,75	13,75	13,75	13,75
	36	A	330,00	334,90	339,90	345,70
		B	71,50	71,50	71,50	71,50
		C	189,75	192,20	194,70	197,60
		D	19,50	19,50	19,50	19,50
		E	13,75	13,75	13,75	13,75
	40	A	334,00	338,90	343,90	349,70
		B	73,50	73,50	73,50	73,50
		C	191,75	194,20	196,70	199,60
		D	19,50	19,50	19,50	19,50
		E	13,75	13,75	13,75	13,75
	45	A	338,50	343,40	348,40	354,20
		B	75,75	75,75	75,75	75,75
		C	194,00	196,45	198,95	201,85
		D	19,50	19,50	19,50	19,50
		E	13,75	13,75	13,75	13,75
50	A	343,50	348,40	353,40	359,20	
	B	78,25	78,25	78,25	78,25	
	C	196,50	198,95	201,45	204,35	
	D	19,50	19,50	19,50	19,50	
	E	13,75	13,75	13,75	13,75	

GR47 + GR38			2°					
			16	18	20	22	25	28
1°	28	A	325,50	328,50	331,50	334,50	339,00	343,50
		B	67,50	67,50	67,50	67,50	67,50	67,50
		C	187,50	189,00	190,50	192,00	194,25	196,50
		D	19,50	19,50	19,50	19,50	19,50	19,50
		E	15,90	15,90	15,90	15,90	15,90	15,90
	32	A	329,50	332,50	335,50	338,50	343,00	347,50
		B	69,50	69,50	69,50	69,50	69,50	69,50
		C	189,50	191,00	192,50	194,00	196,25	198,50
		D	19,50	19,50	19,50	19,50	19,50	19,50
		E	15,90	15,90	15,90	15,90	15,90	15,90

GR47 + GR38			2°					
			16	18	20	22	25	28
	36	A	333,50	336,50	339,50	342,50	347,00	351,50
		B	71,50	71,50	71,50	71,50	71,50	71,50
		C	191,50	193,00	194,50	196,00	198,25	200,50
		D	19,50	19,50	19,50	19,50	19,50	19,50
		E	15,90	15,90	15,90	15,90	15,90	15,90
	40	A	337,50	340,50	343,50	346,50	351,00	355,50
		B	73,50	73,50	73,50	73,50	73,50	73,50
		C	193,50	195,00	196,50	198,00	200,25	202,50
		D	19,50	19,50	19,50	19,50	19,50	19,50
		E	15,90	15,90	15,90	15,90	15,90	15,90
	45	A	342,00	345,00	348,00	351,00	355,50	360,00
		B	75,75	75,75	75,75	75,75	75,75	75,75
		C	195,75	197,25	198,75	200,25	202,50	204,75
		D	19,50	19,50	19,50	19,50	19,50	19,50
		E	15,90	15,90	15,90	15,90	15,90	15,90
	50	A	347,00	350,00	353,00	356,00	360,5	365,00
		B	78,25	78,25	78,25	78,25	78,25	78,25
		C	198,25	199,75	201,25	202,75	205,00	207,25
		D	19,50	19,50	19,50	19,50	19,50	19,50
		E	15,90	15,90	15,90	15,90	15,90	15,90

GR47 + GR47			2°					
			28	32	36	40	45	50
1°	28	A	351,00	-	-	-	-	-
		B	67,50	-	-	-	-	-
		C	201,00	-	-	-	-	-
		D	19,50	-	-	-	-	-
		E	19,50	-	-	-	-	-
	32	A	356,50	360,50	-	--	-	-
		B	69,50	69,50	-	-	-	-
		C	203,00	205,00	-	-	-	-
		D	19,50	19,50	-	-	-	-
		E	19,50	19,50	-	-	-	-
	36	A	360,50	364,50	368,50	-	-	-
		B	71,50	71,50	71,50	-	-	-
		C	205,00	207,00	209,00	-	-	-
		D	19,50	19,50	19,50	-	-	-
		E	19,50	19,50	19,50	-	-	-

GR47 + GR47		2°					
		28	32	36	40	45	50
40	A	364,50	368,50	372,50	376,50	-	-
	B	73,50	73,50	73,50	73,50	-	-
	C	207,00	209,00	211,00	213,00	-	-
	D	19,50	19,50	19,50	19,50	-	-
	E	19,50	19,50	19,50	19,50	-	-
45	A	369,00	373,00	377,00	381,00	385,50	-
	B	75,75	75,75	75,75	75,75	75,75	-
	C	209,25	211,25	213,25	215,25	217,50	-
	D	19,50	19,50	19,50	19,50	19,50	-
	E	19,50	19,50	19,50	19,50	19,50	-
50	A	374,00	378,00	382,00	386,00	390,50	395,50
	B	78,25	78,25	78,25	78,25	78,25	78,25
	C	211,75	213,75	215,75	217,75	220,00	222,50
	D	19,50	19,50	19,50	19,50	19,50	19,50
	E	19,50	19,50	19,50	19,50	19,50	19,50

**Available flanges and shafts for GR47**  
**Flange ed alberi disponibili per GR47**

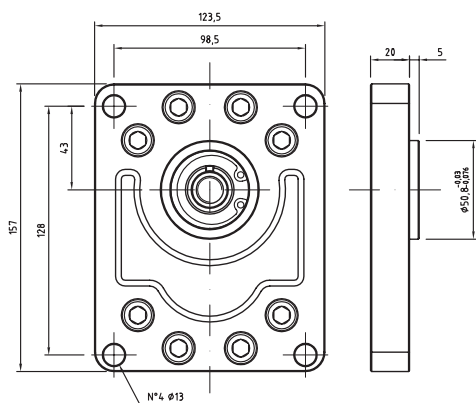

Type flange 3-C9  
 Flangia tipo 3-C9

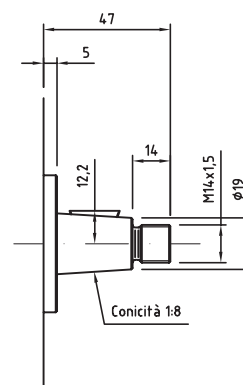

Type shaft 3-C9  
 Albero tipo 3-C9  
 Max torque / Coppia max: 320 Nm

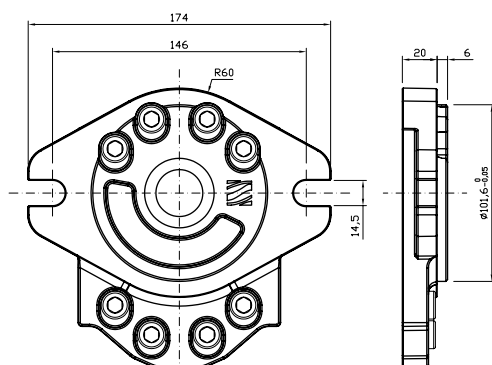

Type flange SAEB-T13  
 Flangia tipo SAEB-T13

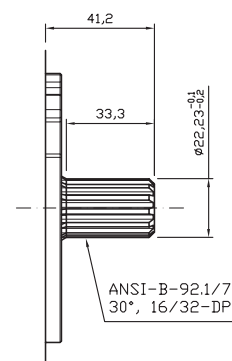

Type shaft SAEB-T13  
 Albero tipo SAEB-T13  
 Max torque / Coppia max: 600 Nm

## GR55 - Group 3 tandem pumps

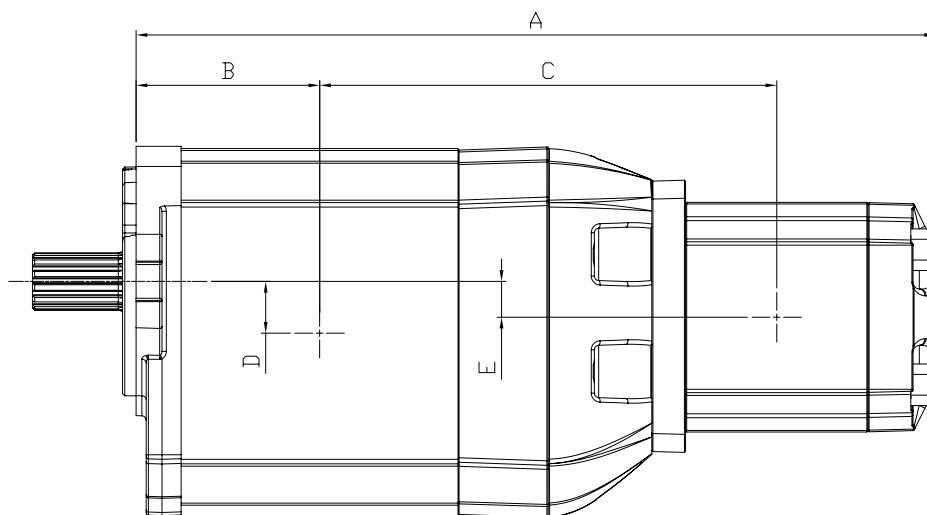

GR55 + GR28			2°				
			4	6	8	10	13
1°	50	A	323,00	328,50	333,50	338,50	345,40
		B	81,50	81,50	81,50	81,50	81,50
		C	185,00	187,75	190,25	192,75	196,25
		D	23,00	23,00	23,00	23,00	23,00
		E	11,90	11,90	11,90	11,90	11,90
	63	A	332,00	337,50	342,50	347,50	354,40
		B	86,00	86,00	86,00	86,00	86,00
		C	246,00	251,50	256,50	261,50	268,50
		D	23,00	23,00	23,00	23,00	23,00
		E	11,90	11,90	11,90	11,90	11,90
	75	A	340,00	345,50	350,50	355,50	362,40
		B	90,00	90,00	90,00	90,00	90,00
		C	193,50	196,25	198,75	201,25	204,75
		D	23,00	23,00	23,00	23,00	23,00
		E	11,90	11,90	11,90	11,90	11,90
	90	A	351,00	356,50	361,50	366,50	373,40
		B	95,50	95,50	95,50	95,50	95,50
		C	199,00	201,75	204,25	206,75	210,25
		D	23,00	23,00	23,00	23,00	23,00
		E	11,90	11,90	11,90	11,90	11,90

GR55 + GR33			2°			
			10	13	15	18
1°	50	A	351,50	356,40	361,40	367,20
		B	81,50	81,50	81,50	81,50
		C	201,25	203,70	206,20	209,10
		D	23,00	23,00	23,00	23,00
		E	13,75	13,75	13,75	13,75
	63	A	360,50	365,40	370,40	376,20
		B	86,00	86,00	86,00	86,00
		C	274,50	279,40	284,40	290,20
		D	23,00	23,00	23,00	23,00
		E	13,75	13,75	13,75	13,75
	75	A	368,50	373,40	378,40	384,20
		B	90,00	90,00	90,00	90,00
		C	209,75	212,20	214,70	217,60
		D	23,00	23,00	23,00	23,00
		E	13,75	13,75	13,75	13,75
	90	A	379,50	384,40	389,40	395,20
		B	95,50	95,50	95,50	95,50
		C	215,25	217,70	220,0	223,10
		D	23,00	23,00	23,00	23,00
		E	13,75	13,75	13,75	13,75

GR55 + GR33			2°			
			10	13	15	18
1°	50	A	351,50	356,40	361,40	367,20
		B	81,50	81,50	81,50	81,50
		C	201,25	203,70	206,20	209,10
		D	23,00	23,00	23,00	23,00
		E	13,75	13,75	13,75	13,75
	63	A	360,50	365,40	370,40	376,20
		B	86,00	86,00	86,00	86,00
		C	274,50	279,40	284,40	290,20
		D	23,00	23,00	23,00	23,00
		E	13,75	13,75	13,75	13,75
	75	A	368,50	373,40	378,40	384,20
		B	90,00	90,00	90,00	90,00
		C	209,75	212,20	214,70	217,60
		D	23,00	23,00	23,00	23,00
		E	13,75	13,75	13,75	13,75
	90	A	379,50	384,40	389,40	395,20
		B	95,50	95,50	95,50	95,50
		C	215,25	217,70	220,20	223,10
		D	23,00	23,00	23,00	23,00
		E	13,75	13,75	13,75	13,75

GR55 + GR38			2°					
			16	18	20	22	25	28
1°	50	A	355,00	358,00	361,00	364,00	368,50	373,00
		B	81,50	81,50	81,50	81,50	81,50	81,50
		C	203,00	204,50	206,00	207,50	209,75	212,00
		D	23,00	23,00	23,00	23,00	23,00	23,00
		E	15,90	15,90	15,90	15,90	15,90	15,90
	63	A	364,00	367,00	370,00	373,00	377,50	382,00
		B	86,00	86,00	86,00	86,00	86,00	86,00
		C	278,00	281,00	284,00	287,00	291,50	296,00
		D	23,00	23,00	23,00	23,00	23,00	23,00
		E	15,90	15,90	15,90	15,90	15,90	15,90
	75	A	372,00	375,00	378,00	381,00	385,50	390,00
		B	90,00	90,00	90,00	90,00	90,00	90,00
		C	211,50	213,00	214,50	216,00	218,25	220,50
		D	23,00	23,00	23,00	23,00	23,00	23,00
		E	15,90	15,90	15,90	15,90	15,90	15,90
	90	A	383,00	386,00	389,00	392,00	396,50	401,00
		B	95,50	95,50	95,50	95,50	95,50	95,50
		C	217,00	218,50	220,00	221,50	223,75	226,00
		D	23,00	23,00	23,00	23,00	23,00	23,00
		E	15,90	15,90	15,90	15,90	15,90	15,90

GR55 + GR47			2°					
			28	32	36	40	45	50
1°	50	A	387,00	391,00	395,00	400,50	403,50	408,50
		B	81,50	81,50	81,50	81,50	81,50	81,50
		C	223,00	225,00	227,00	229,00	231,25	233,75
		D	23,00	23,00	23,00	23,00	23,00	23,00
		E	19,50	19,50	19,50	19,50	19,50	19,50
	63	A	396,00	400,00	404,00	408,00	412,50	417,50
		B	86,00	86,00	86,00	86,00	86,00	86,00
		C	310,00	314,00	318,00	322,00	326,50	331,50
		D	23,00	23,00	23,00	23,00	23,00	23,00
		E	19,50	19,50	19,50	19,50	19,50	19,50
	75	A	404,00	408,00	412,00	416,00	420,50	425,50
		B	90,00	90,00	90,00	90,00	90,00	90,00
		C	231,50	233,50	235,50	237,50	239,75	242,25
		D	23,00	23,00	23,00	23,00	23,00	23,00
		E	19,50	19,50	19,50	19,50	19,50	19,50
	90	A	415,00	418,00	423,00	427,00	431,50	436,50
		B	95,50	95,50	95,50	95,50	95,50	95,50
		C	237,00	239,00	241,00	243,00	245,25	247,75
		D	23,00	23,00	23,00	23,00	23,00	23,00
		E	19,50	19,50	19,50	19,50	19,50	19,50

GR55 + GR55		2°				
		50	63	75	90	
1°	50	A	415,00	-	-	-
		B	81,50	-	-	-
		C	237,00	-	-	-
		D	23,00	-	-	-
		E	19,50	-	-	-
	63	A	424,00	433,00	-	-
		B	86,00	86,00	-	-
		C	338,00	347,00	-	-
		D	23,00	23,00	-	-
		E	19,50	19,50	-	-
	75	A	432,00	441,00	449,00	-
		B	90,00	90,00	90,00	-
		C	245,50	250,00	254,00	-
		D	23,00	23,00	23,00	-
		E	19,50	19,50	19,50	-
	90	A	443,00	452,00	460,00	471,00
		B	95,50	95,50	95,50	95,50
		C	251,00	255,50	259,50	265,00
		D	23,00	23,00	23,00	23,00
		E	19,50	19,50	19,50	19,50

**Available flanges and shafts for GR55**  
**Flange ed alberi disponibili per GR55**

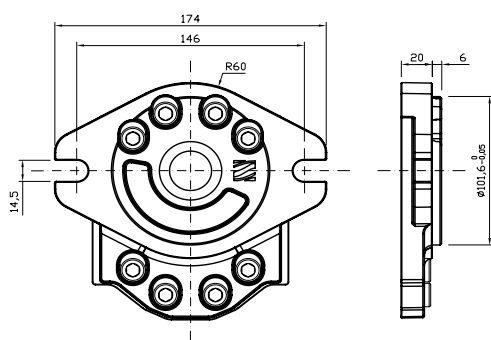

Type flange SAEB-T15  
 Flangia tipo SAEB-T15

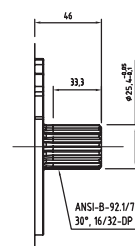

Type shaft SAEB-T15  
 Albero tipo SAEB-T15  
 Max torque / Coppia max: 700 Nm



## GR72 - Group 4 tandem pumps

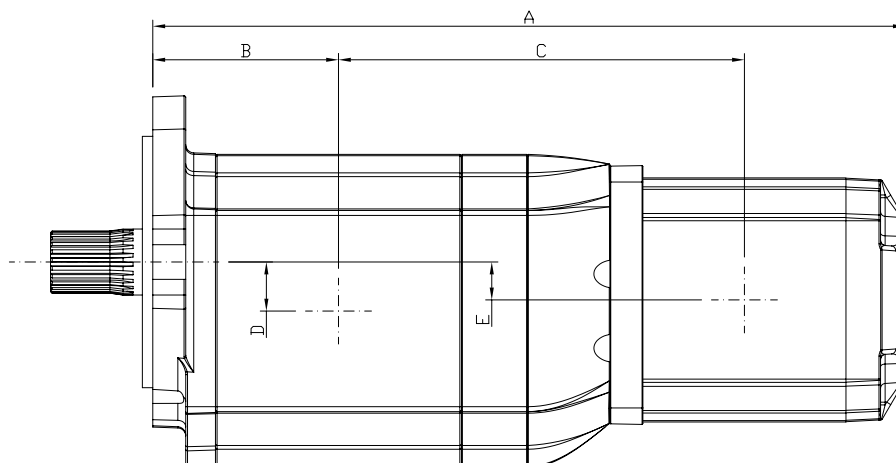

GR72 + GR47			2°					
			28	32	36	40	45	50
1°	94	A	440,00	444,00	448,00	452,00	456,50	461,50
		B	125,50	125,50	125,50	125,50	125,50	125,50
		C	232,00	234,00	236,00	238,00	240,25	242,75
		D	29,75	29,75	29,75	29,75	29,75	29,75
		E	19,50	19,50	19,50	19,50	19,50	19,50
	101	A	443,00	447,00	451,00	455,00	459,50	464,50
		B	127,00	127,00	127,00	127,00	127,00	127,00
		C	316,00	320,00	324,00	328,00	332,50	337,50
		D	29,75	29,75	29,75	29,75	29,75	29,75
		E	19,50	19,50	19,50	19,50	19,50	19,50
	125	A	453,00	457,00	461,00	465,00	469,50	474,50
		B	132,00	132,00	132,00	132,00	132,00	132,00
		C	238,50	240,50	242,50	244,50	246,75	249,25
		D	29,75	29,75	29,75	29,75	29,75	29,75
		E	19,50	19,50	19,50	19,50	19,50	19,50
	150	A	463,50	467,50	471,50	475,50	480,00	485,00
		B	137,25	137,25	137,25	137,25	137,25	137,25
		C	243,75	245,75	247,75	249,75	252,00	254,50
		D	29,75	29,75	29,75	29,75	29,75	29,75
		E	19,50	19,50	19,50	19,50	19,50	19,50
175	A	473,50	477,50	481,50	485,50	490,00	495,00	
	B	142,25	142,25	142,25	142,25	142,25	142,25	
	C	248,75	245,75	247,75	249,75	252,00	254,50	
	D	29,75	29,75	29,75	29,75	29,75	29,75	
	E	19,50	19,50	19,50	19,50	19,50	19,50	
200	A	484,00	488,00	492,00	496,00	500,50	505,50	
	B	147,50	147,50	147,50	147,50	147,50	147,50	
	C	254,00	256,00	258,00	260,00	262,25	264,75	
	D	29,75	29,75	29,75	29,75	29,75	29,75	
	E	19,50	19,50	19,50	19,50	19,50	19,50	

GR72 + GR55			2°			
			50	63	75	90
1°	94	A	468,00	477,00	485,00	496,00
		B	125,50	125,50	125,50	125,50
		C	246,00	250,50	254,50	260,00
		D	29,75	29,75	29,75	29,75
		E	19,50	19,50	19,50	19,50
	101	A	471,00	480,00	488,00	499,00
		B	127,00	127,00	127,00	127,00
		C	344,00	353,00	361,00	372,00
		D	29,75	29,75	29,75	29,75
		E	19,50	19,50	19,50	19,50
	125	A	481,00	490,00	498,00	509,00
		B	132,00	132,00	132,00	132,00
		C	252,50	257,00	261,00	266,50
		D	29,75	29,75	29,75	29,75
		E	19,50	19,50	19,50	19,50
	150	A	491,50	500,50	508,50	519,50
		B	137,25	137,25	137,25	137,25
		C	257,75	262,25	266,25	271,75
		D	29,75	29,75	29,75	29,75
		E	19,50	19,50	19,50	19,50
	175	A	501,50	510,50	518,50	529,50
		B	142,25	142,25	142,25	142,25
		C	262,75	267,25	271,25	276,75
		D	29,75	29,75	29,75	29,75
		E	19,50	19,50	19,50	19,50
200	A	512,00	521,00	529,00	540,00	
	B	147,50	147,50	147,50	147,50	
	C	268,00	272,50	276,50	282,00	
	D	29,75	29,75	29,75	29,75	
	E	19,50	19,50	19,50	19,50	

GR72 + GR72			2°					
			94	100	125	150	175	200
1°	94	A	556,50	-	-	-	-	-
		B	125,50	-	-	-	-	-
		C	311,50	-	-	-	-	-
		D	29,75	-	-	-	-	-
		E	29,75	-	-	-	-	-
	100	A	559,50	562,50	-	-	-	-
		B	127,00	127,00	-	-	-	-
		C	432,50	435,50	-	-	-	-
		D	29,75	29,75	-	-	-	-
		E	29,75	29,75	-	-	-	-

GR72 + GR72			2°					
			94	100	125	150	175	200
125	A	569,50	572,50	582,50	-	-	-	
	B	132,00	132,00	132,00	-	-	-	
	C	318,00	319,50	324,50	-	-	-	
	D	29,75	29,75	29,75	-	-	-	
	E	29,75	29,75	29,75	-	-	-	
150	A	580,00	583,00	593,00	603,50	-	-	
	B	137,25	137,25	137,25	137,25	-	-	
	C	323,25	324,75	329,75	335,00	-	-	
	D	29,75	29,75	29,75	29,75	-	-	
	E	29,75	29,75	29,75	29,75	-	-	
175	A	590,00	593,00	603,00	613,50	623,50	-	
	B	142,25	142,25	142,25	142,25	142,25	-	
	C	328,25	329,75	334,75	340,00	345,00	-	
	D	29,75	29,75	29,75	29,75	29,75	-	
	E	29,75	29,75	29,75	29,75	29,75	-	
200	A	600,50	603,50	613,50	624,00	634,00	644,50	
	B	147,50	147,50	147,50	147,50	147,50	147,50	
	C	333,50	335,00	340,00	345,25	350,25	355,50	
	D	29,75	29,75	29,75	29,75	29,75	29,75	
	E	29,75	29,75	29,75	29,75	29,75	29,75	

**Available flanges and shafts for GR72**  
**Flange ed alberi disponibili per GR72**

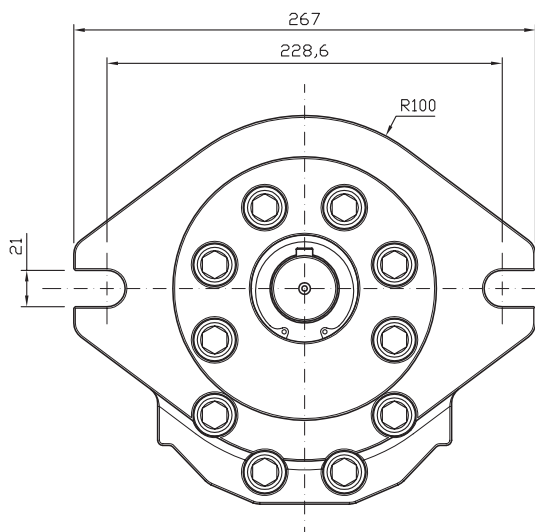

Type flange SAED-23T  
 Flangia tipo SAED-23T

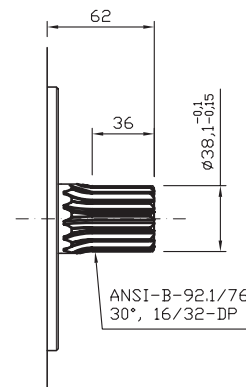
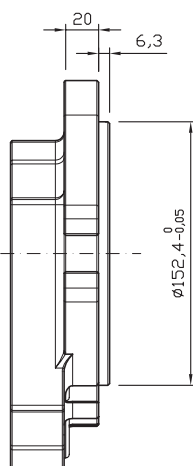

Type flange SAED-23T  
 Flangia tipo SAED-23T  
 Max torque / Coppia max: 1200 Nm

**SETTIMA**

**Settima, Italy**

Headquarter, r&d and production

**SETTIMA**

USA  
Warehouse

**SETTIMA**

Shanghai, China  
Warehouse

**Settima Meccanica Srl**  
Settima - 29020 Piacenza (Italia)  
tel. +39 0523.557623  
fax +39 0523.557256  
[www.settima.it](http://www.settima.it)  
[info@settima.it](mailto:info@settima.it)

**Settima Flow Mechanisms**  
Settima - 29020 Piacenza (Italia)  
tel. +39 0523.557623  
fax +39 0523.557256  
[www.settima.it](http://www.settima.it)  
[info@settimafm.com](mailto:info@settimafm.com)