



Contents

Introduction.....	128	Double Rod Cylinders.....	138
Features, Specifications and Mountings.....	129	Accessories	139-141
Design Features and Benefits	130-131	Model Numbers	142-143
Mounting Styles	132	Parts I.D. and Seal Kits	Sec. C, pgs. 45-46
Piston Rod End Data / Thread Styles.....	133	Application Engineering Data	Sec. C, pgs. 91-102
Mounting Information.....	134-137		

B

PL-2

PH-2

PH-3

PHX

SHM

CHE/CHD

SHM Series Metric Hydraulic Cylinders

As a world leader in the design and manufacture of pneumatic and hydraulic cylinders, Schrader Bellows Industrial Cylinder Division offers the SHM Series *metric* hydraulic cylinder. Schrader Bellows' SHM Series cylinders are designed to meet the requirements of ISO 6020/2 (1991), 160 Bar Compact Series. SHM Series cylinders may be used for working pressures up to 210 Bar.

Schrader Bellows SHM Series cylinders are the true *world standard*, available all over the globe from worldwide manufacturing facilities.



Introduction

The SHM Series cylinders described in this catalog are Compact Series cylinders to ISO 6020/2 rated for use at working pressures up to 210 bar. They have been designed to satisfy the requirements of a wide range of industries in which cylinders to ISO standards are specified.

In addition to the standard cylinders featured in this catalog, SHM cylinders can be designed to suit customer requirements. Our engineers will be pleased to advise on unique designs to suit specific applications.

SHM Series Standard Features and Specifications

- ISO 6020/2 mounting interchangeable
- 12 standard mounting styles
- Up to 3 rod sizes per bore
- Wide range of mounting accessories
- Up to 3 male and 3 female rod end threads per bore
- Bore sizes – 25mm to 200mm
- Strokes – available in any practical stroke length
- Working pressure up to 210 bar
- Piston rods – 12mm to 140mm
- Single and Double rod designs
- Cushions available at either or both ends
- Temperature Range – -20°C to +150°C depending on seal type
- Seal types to suit a wide variety of operating environments

In line with our policy of continuing product improvement, specifications in this catalog are subject to change.

Available Mountings

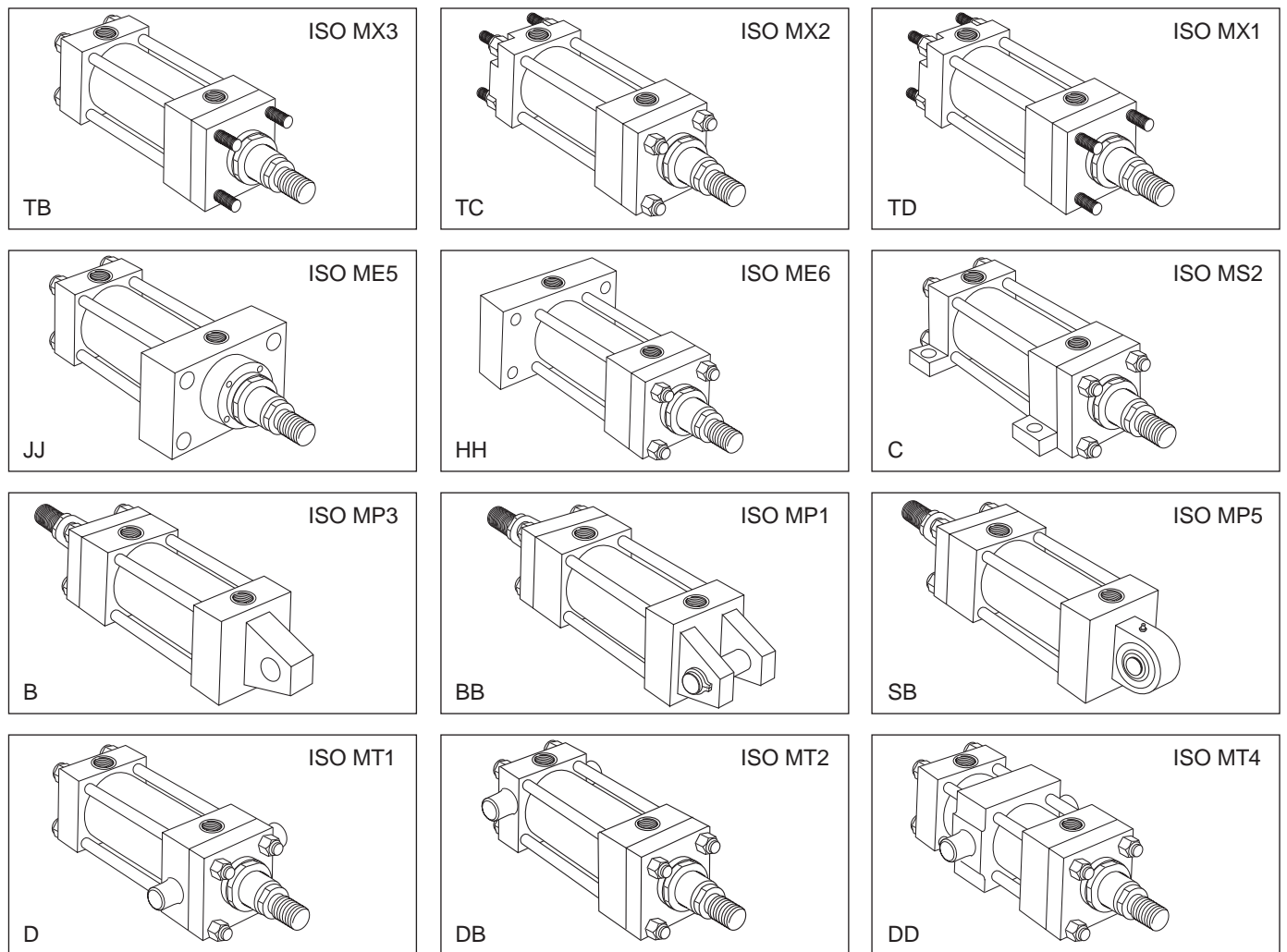

B

PL-2

PH-2

PH-3

PHX

SHM

CHE/CHD

Here is the inside story of why the SHM Series is your best choice in a metric heavy duty hydraulic cylinder...

1 Piston Rod

Gland seal life is maximized by manufacturing piston rods from precision ground, high tensile carbon steel, hard chrome plated and polished to 0.2µm max. Piston rods are induction case hardened to Rockwell C54 minimum before chrome plating, resulting in a dent-resistant surface.

2 Schrader Bellows 'Quick' Gland

Continuous lubrication, and therefore longer gland life, are provided by the long bearing surface inboard of the primary seal. The gland, complete with rod seals, can easily be removed without dismantling the cylinder and without special tools, so servicing is quicker – and therefore more economical.

3 Rod Seals

The Tuff Seal primary seal has a series of sealing edges which take over successively as pressure increases, providing efficient sealing under all operating conditions. On the return stroke the serrations act as a check valve, allowing the oil adhering to the rod to pass back into the cylinder.

The double lip wiperseal acts as a secondary seal, trapping excess lubricating film in the chamber between the wiper and lip seals. Its outer lip prevents the ingress of dirt into the cylinder, extending the life of gland and seals.

The Tuff Seal is manufactured from an enhanced polyurethane, giving efficient retention of pressurized fluid and long service life.

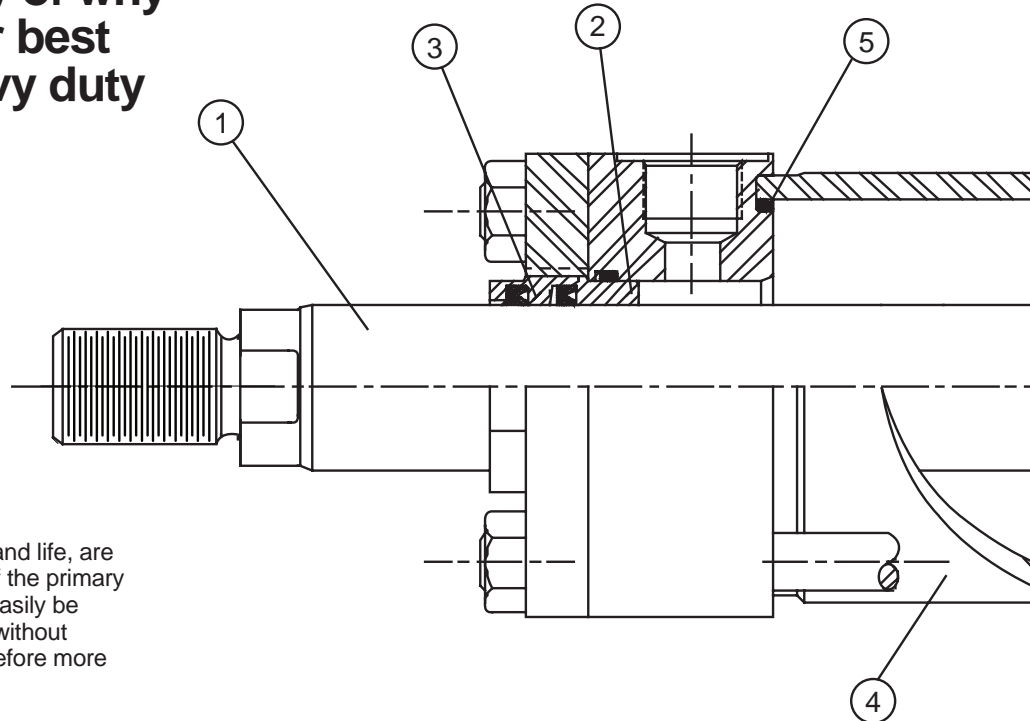

4 Cylinder Body

Strict quality control standards and precision manufacture ensure that all tubes meet rigid standards of straightness, roundness and surface finish. The steel tubing is surface finished to minimize internal friction and prolong seal life.

5 Cylinder Body Seals

To make sure that the cylinder body remains leak-free, even under pressure shock conditions, Schrader Bellows utilizes pressure-energized body seals.

6 One-Piece Piston

Side loading is resisted by wear rings on the piston. A long thread engagement secures the piston to the piston rod and, as an added feature, pistons are secured by an anaerobic adhesive.

Optional

Air Bleeds

Available as an option at both ends, the air bleeds are recessed into the head and cap.

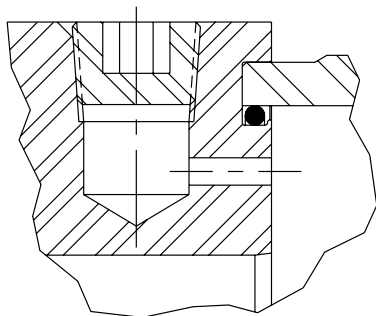

Servo Cylinders

Servo cylinders permit fine control of acceleration, velocity and position in applications where very low friction and an absence of stick-slip are required. They may be used in conjunction with integral or external transducers. Servo cylinders combine low friction piston and gland seals with specially selected tubes and rods. For low-friction applications – consult factory.

Seal Classes

To accommodate the many types of fluids and the varying temperature ranges used in industry, Schrader Bellows offers a range of rod gland, piston and body seals.

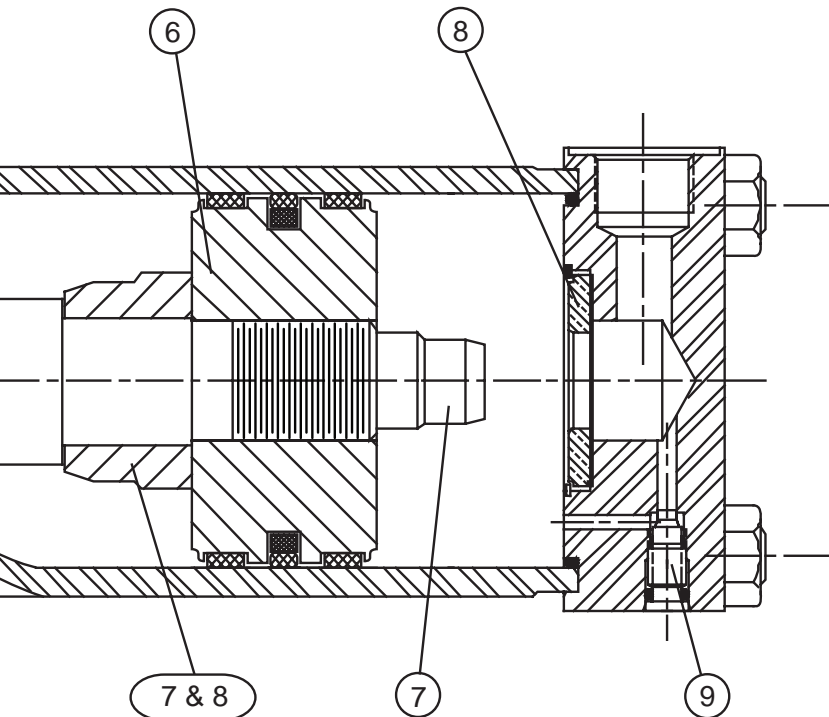

7 Cushioning

Progressive deceleration is available by using profiled cushions at the head and cap. The head end cushion is self aligning, while the polished cap end spear is an integral part of the piston rod.

8 Floating Cushion Bushings and Sleeves

Closer tolerances – and therefore more effective cushioning – are permitted by the use of a floating cushion sleeve at the head end of the cylinder, and a floating cushion bushing at the cap end. A slotted cushion sleeve on the head end, and the floating bronze cushion bushing in the cap, provide minimum fluid restriction at the start of the return stroke. This allows full pressure to be applied over the entire area of the piston, providing full power and fast cycle times.

Gland Drains

The accumulation of fluid behind the gland wiperseal of long stroke cylinders, or cylinders with constant back pressure, can be relieved by specifying the option of a gland drain. A port between the wiperseal and primary seal allows fluid to be piped back to a reservoir. By fitting a transparent tube between the port and the reservoir, fluid loss from concealed or inaccessible cylinders can be monitored to provide an early indication of the need for gland servicing.

9 Cushion Adjustment

Needle valves are provided at both ends of the cylinder for precise cushion adjustment.

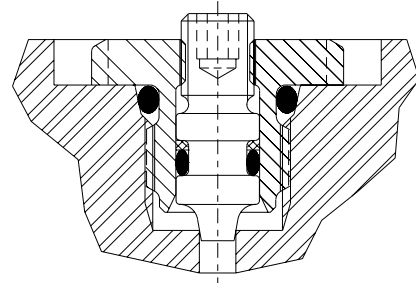

10 Piston Seals

Standard on 25mm, 32mm and 40mm bore sizes, Schrader's Lipseal™ Piston provides zero leakage under static conditions for hydraulic pressures up to 3000 psi. Seals are self-compensating to conform to variations in pressure, mechanical deflection, and wear. Back-up washers prevent extrusion.

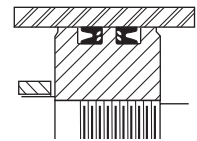

Standard on 50mm bore sizes and larger, Schrader's B style piston is a single seal design which incorporates two wear strips. This design provides smooth operation, long bearing life, and high load carrying capacity.

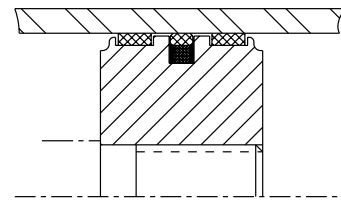

Mixed Media Piston Seals

For applications requiring different media on either side of the piston specify Mixed Media Piston Seals with a W piston code. This option is ideal when hydraulic oil is on one side of the piston and air on the opposite side; and it can be equally effective when dissimilar fluids are on either side of the piston. Superior low-friction bi-directional sealing is accomplished by combining an energized filled PTFE seal with a redundant elastomer seal.

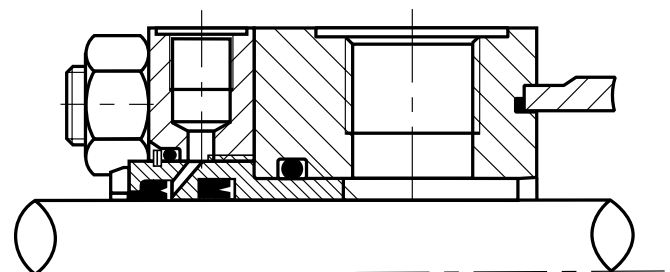

ISO Cylinder Mounting Styles

The standard range of Schrader Bellows SHM Series cylinders comprises 12 ISO mounting styles, to suit the majority of applications. General guidance for the selection of ISO cylinders is given below, with dimensional information about each mounting style shown on the following pages. Application-specific mounting information is shown in the Mounting Information section of this catalog.

Extended Tie Rods

Cylinders with TB, TC and TD mountings are suitable for straight line force transfer applications, and are particularly useful where space is limited. For compression (push) applications, cap end tie rod mountings are most appropriate; where the major load places the piston rod in tension (pull applications), head end mounting styles should be specified. Cylinders with tie rods extended at both ends may be attached to the machine member from either end, allowing the free end of the cylinder to support a bracket or switch.

Flange Mounted Cylinders

These cylinders are also suitable for use on straight line force transfer applications. Two flange mounting styles are available, offering either a head flange (JJ) or a cap flange (HH). Selection of the correct flange mounting style depends on whether the major force applied to the load will result in compression (push) or tension (pull) stresses on the piston rod. For compression-type applications, the cap mounting style is most appropriate; where the major load places the piston rod in tension, a head mounting should be specified.

Foot Mounted Cylinders

Style C, foot mounted cylinders do not absorb forces on their centerline. As a result, the application of force by the cylinder produces a moment which attempts to rotate the cylinder about its mounting bolts. It is important, therefore, that the cylinder should be firmly secured to the mounting surface and that the load should be effectively guided to avoid side loads being applied to rod gland and piston bearings. A thrust key modification may be specified to provide positive cylinder location.

Pivot Mountings

Cylinders with pivot mountings, which absorb forces on their centerlines, should be used where the machine member to be moved travels in a curved path. Pivot mountings may be used for tension (pull) or compression (push) applications. Cylinders using a fixed clevis, styles BB and B, may be used if the curved path of the piston rod travel is in a single plane; for applications where the piston rod will travel in a path on either side of the true plane of motion, a spherical bearing mounting SB is recommended.

Trunnion Mounted Cylinders

These cylinders, styles D, DB and DD, are designed to absorb force on their centerlines. They are suitable for tension (pull) or compression (push) applications, and may be used where the machine member to be moved travels in a curved path in a single plane. Trunnion pins are designed for shear loads only and should be subjected to minimum bending stresses.

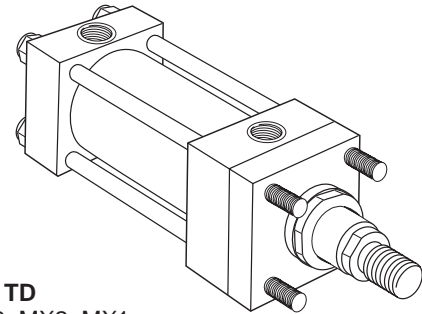

Styles TB, TC, TD
ISO Styles MX3, MX2, MX1

TB

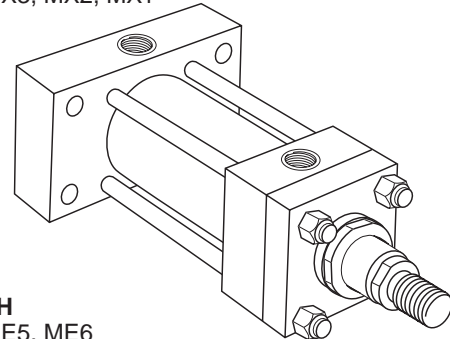

Styles JJ, HH
ISO Styles ME5, ME6

HH

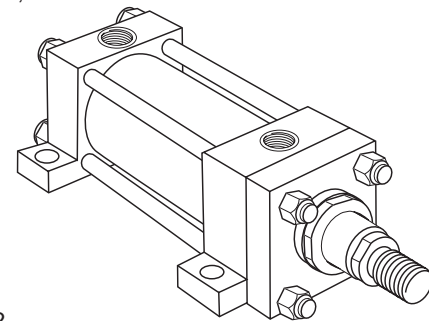

Style C
ISO Style MS2

C

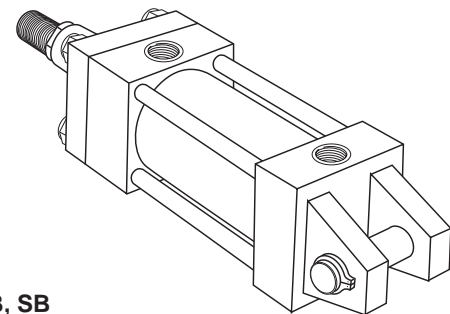

Styles B, BB, SB
ISO Styles MP3, MP1, MP5

BB

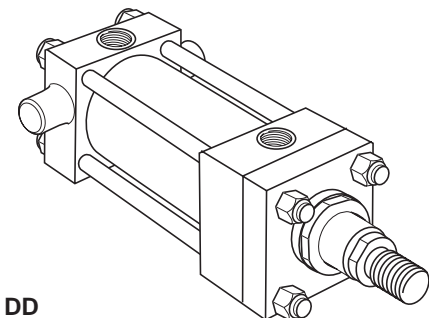

Styles D, DB, DD
ISO Styles MT1, MT2, MT4

DB

**Thread Styles 4 & 7 –
All Except JJ Mount**

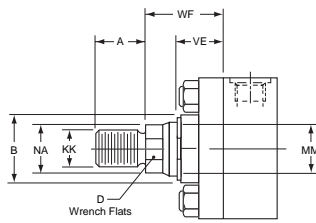

**Thread Styles 4 & 7 –
JJ Mount**

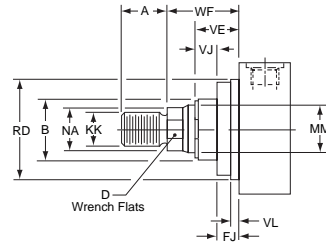

**Thread Style 9 –
All Except JJ Mount**

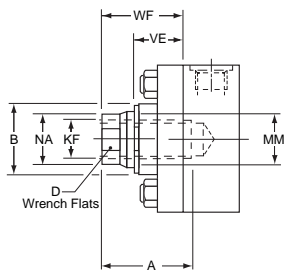

**Thread Style 9 –
JJ Mount**

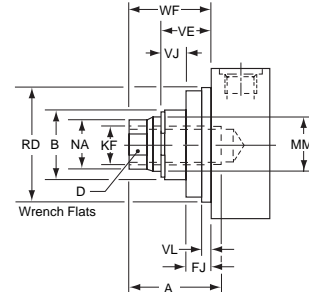

Thread Styles 4 & 7

The smallest diameter rod end thread for each bore size is designated Style 4 when supplied with a No. 1 rod. When the same rod end thread is supplied with a No. 2 or No. 3 rod, it is designated Style 7.

**Thread Style 9 –
Short Stroke Cylinders**

Style 9 (female) rod ends should not be used on 160mm or 200mm bore cylinders with a stroke of 50mm or less. Please consult the factory, with details of the application.

Thread Style 3

Non-standard piston rod ends are designated 'Style 3'. A dimensional sketch or description should accompany the order. Please specify dimensions KK or KF, A, rod stand out WF and thread type.

25 & 32mm Bore Cylinders

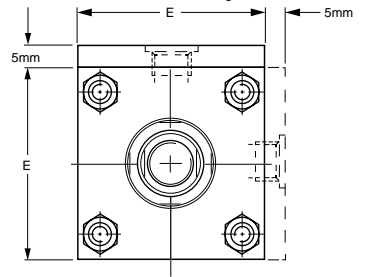

5mm extra height applies to port face at head end only.

**Gland Retainer –
160 and 200mm Bore**

On all 160mm and 200mm bore ISO mounting styles except TB and TD, the gland retainer is separately bolted to the head, as shown.

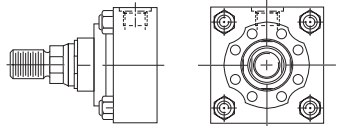

Piston Rod End Dimensions

Bore Φ	Rod No.	MM Rod Φ	Style 4		Style 7		Style 9		B f9	D	NA	VE	WF	JJ Mount Only			
			KK	A	KK	A	KF	A						VL min	RD f8	VJ	FJ
25	1	12	M10x1.25	14	-	-	M8x1	14	24	10	11	16	25	3	38	6	10
	2	18	M14x1.5	18	M10x1.25	14	M12x1.25	18	30	15	17	16					
32	1	14	M12x1.25	16	-	-	M10x1.25	16	26	12	13	22	35	3	42	12	10
	2	22	M16x1.5	22	M12x1.25	16	M16x1.5	22	34	18	21	22					
40	1	18	M14x1.5	18	-	-	M12x1.25	18	30	15	17	16	35	3	62	6	10
	2	28	M20x1.5	28	M14x1.5	18	M20x1.5	28	42	22	26	22					
50	1	22	M16x1.5	22	-	-	M16x1.5	22	34	18	21	22	41	4	74	6	16
	2	36	M27x2	36	M16x1.5	22	M27x2	36	50	30	34	25					
	3	28	M20x1.5	28	M16x1.5	22	M20x1.5	28	42	22	26	22					
63	1	28	M20x1.5	28	-	-	M20x1.5	28	42	22	26	22	48	4	75	6	16
	2	45	M33x2	45	M20x1.5	28	M33x2	45	60	39	43	29					
	3	36	M27x2	36	M20x1.5	28	M27x2	36	50	30	34	25					
80	1	36	M27x2	36	-	-	M27x2	36	50	30	34	25	51	4	82	5	20
	2	56	M42x2	56	M27x2	36	M42x2	56	72	48	54	29					
	3	45	M33x2	45	M27x2	36	M33x2	45	60	39	43	29					
100	1	45	M33x2	45	-	-	M33x2	45	60	39	43	29	57	5	92	7	22
	2	70	M48x2	63	M33x2	45	M48x2	63	88	62	68	32					
	3	56	M42x2	56	M33x2	45	M42x2	56	72	48	54	29					
125	1	56	M42x2	56	-	-	M42x2	56	72	48	54	29	57	5	105	9	20
	2	90	M64x3	85	M42x2	56	M64x3	85	108	80	88	32					
	3	70	M48x2	63	M42x2	56	M48x2	63	88	62	68	32					
160	1	70	M48x2	63	-	-	M48x2	63	88	62	68	32	57	5	125	10	22
	2	110	M80x3	95	M48x2	63	M80x3	95	133	100	108	32					
	3	90	M64x3	85	M48x2	63	M64x3	85	108	80	88	32					
200	1	90	M64x3	85	-	-	M64x3	85	108	80	88	32	57	5	150	10	22
	2	140	M100x3	112	M64x3	85	M100x3	112	163	128	138	32					
	3	110	M80x3	95	M64x3	85	M80x3	95	133	100	108	32					

All dimensions are in millimeters unless otherwise stated.

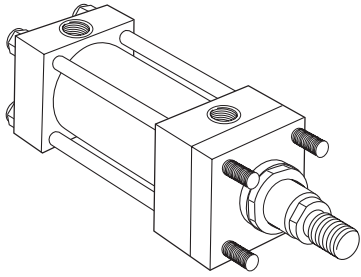

Style TB
Tie Rods Extended Head End
(ISO Style MX3)

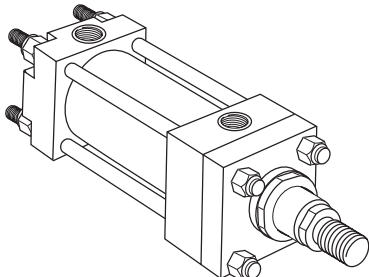
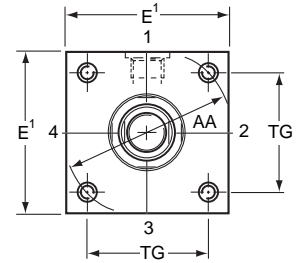
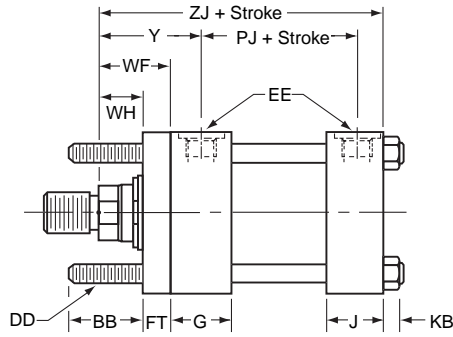

Style TC
Tie Rods Extended Cap End
(ISO Style MX2)

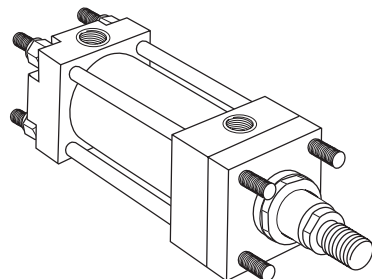
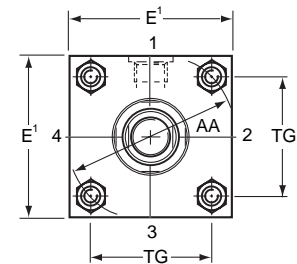
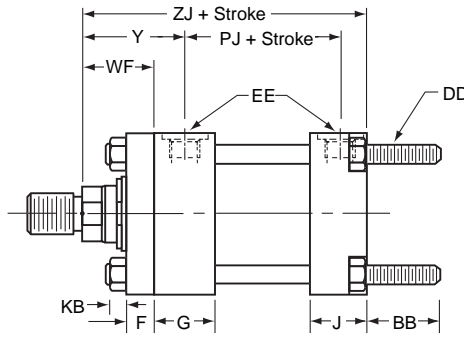

Style TD
Tie Rods Extended Both Ends
(ISO Style MX1)

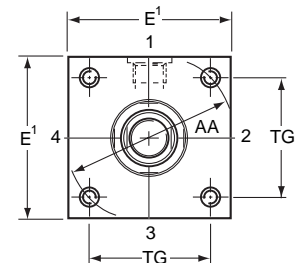
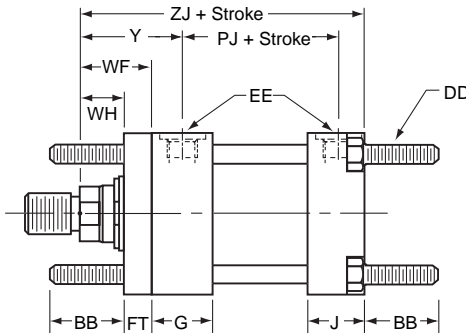

¹Head depth increased by 5mm to accommodate port on 25mm and 32mm bore cylinders – see 25 & 32mm Bore Head data page.

Dimensions – TB, TC & TD See also Rod End Dimensions and Mounting Information

Bore ø	AA	BB	DD	E	EE BSP/G inches	F	FT	G	J	KB	TG	WF	WH	Y	+ Stroke	
															PJ	ZJ
25	40	19	M5x0.8	40 ¹	1/4	10	10	40	25	4	28.3	25	15	50	53	114
32	47	24	M6x1	45 ¹	1/4	10	10	40	25	5	33.2	35	25	60	56	128
40	59	35	M8x1	63	3/8	10	10	45	38	6.5	41.7	35	25	62	73	153
50	74	46	M12x1.25	75	1/2	16	16	45	38	10	52.3	41	25	67	74	159
63	91	46	M12x1.25	90	1/2	16	16	45	38	10	64.3	48	32	71	80	168
80	117	59	M16x1.5	115	3/4	20	20	50	45	13	82.7	51	31	77	93	190
100	137	59	M16x1.5	130	3/4	22	22	50	45	13	96.9	57	35	82	101	203
125	178	81	M22x1.5	165	1	22	22	58	58	18	125.9	57	35	86	117	232
160	219	92	M27x2	205	1	25	25	58	58	22	154.9	57	32	86	130	245
200	269	115	M30x2	245	1-1/4	25	25	76	76	24	190.2	57	32	98	165	299

All dimensions are in millimeters unless otherwise stated.

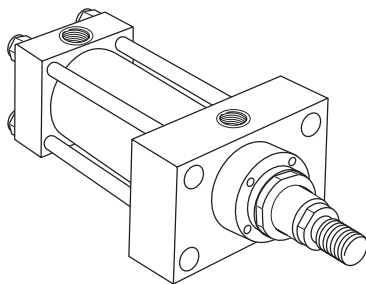

Style JJ
Head Rectangular Flange
(ISO Style ME5)

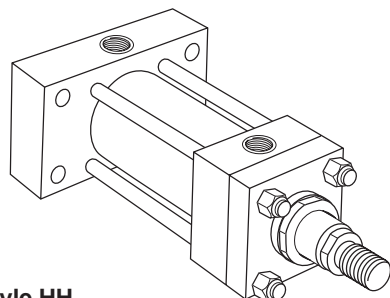
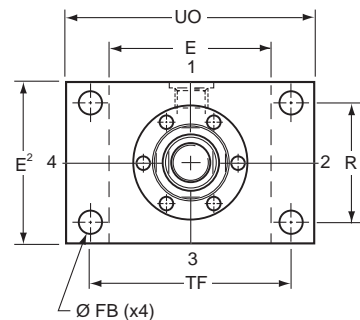
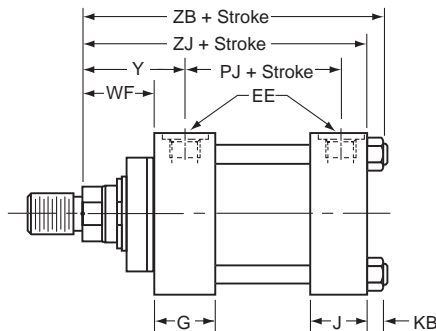

Style HH
Cap Rectangular Flange
(ISO Style ME6)

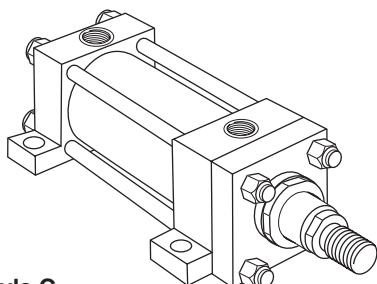
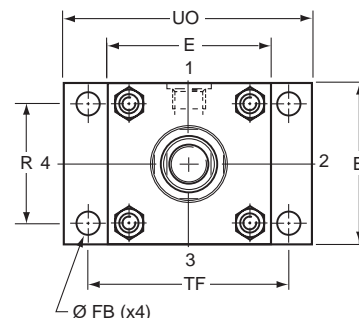
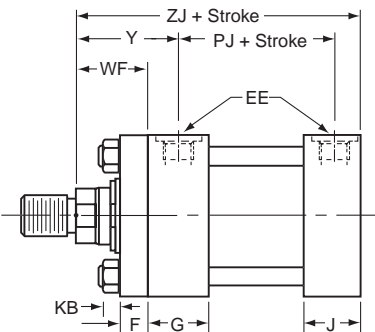

Style C
Side Lugs
(ISO Style MS2)

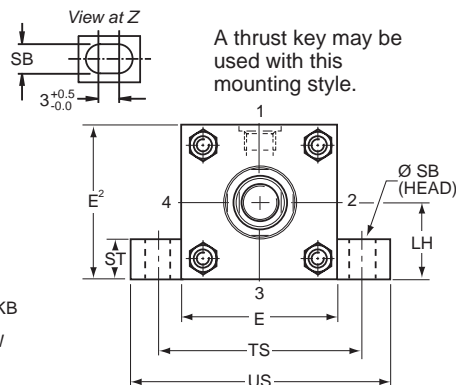
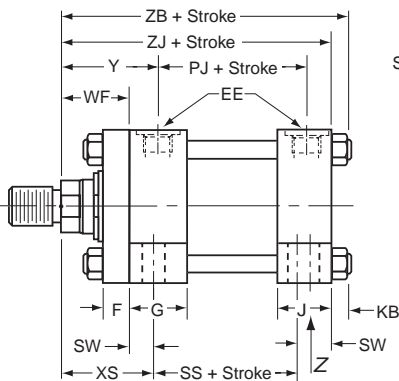

¹Head depth increased by 5mm to accommodate port on 25mm and 32mm bore cylinders.

²On 25mm and 32 mm bore C mount and JJ mount cylinders with port in position 2 or 4, head depth E is increased by 5mm in position 1.

Dimensions – JJ, HH & C See also Rod End Dimensions and Mounting Information.

Bore ø	E	EE BSP/G inches	F	FB	G	J	KB	LH h10	R	SB	ST	SW	TF	TS	UO	US	WF	XS	Y	+ Stroke			
																				PJ	SS	ZB	ZJ
25	40 ¹	1/4	10	5.5	40	25	4	19	27	6.6	8.5	8	51	54	65	72	25	33	50	53	72	121	114
32	45 ¹	1/4	10	6.6	40	25	5	22	33	9	12.5	10	58	63	70	84	35	45	60	56	72	137	128
40	63	3/8	10	11	45	38	6.5	31	41	11	12.5	10	87	83	110	103	35	45	62	73	97	166	153
50	75	1/2	16	14	45	38	10	37	52	14	19	13	105	102	130	127	41	54	67	74	91	176	159
63	90	1/2	16	14	45	38	10	44	65	18	26	17	117	124	145	161	48	65	71	80	85	185	168
80	115	3/4	20	18	50	45	13	57	83	18	26	17	149	149	180	186	51	68	77	93	104	212	190
100	130	3/4	22	18	50	45	13	63	97	26	32	22	162	172	200	216	57	79	82	101	101	225	203
125	165	1	22	22	58	58	18	82	126	26	32	22	208	210	250	254	57	79	86	117	130	260	232
160	205	1	25	26	58	58	22	101	155	33	38	29	253	260	300	318	57	86	86	130	129	279	245
200	245	1-1/4	25	33	76	76	24	122	190	39	44	35	300	311	360	381	57	92	98	165	171	336	299

All dimensions are in millimeters unless otherwise stated.

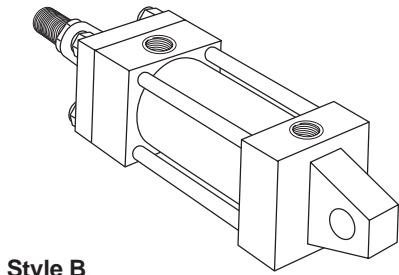

Style B
Cap Fixed Eye
(ISO Style MP3)

Pivot pin not supplied

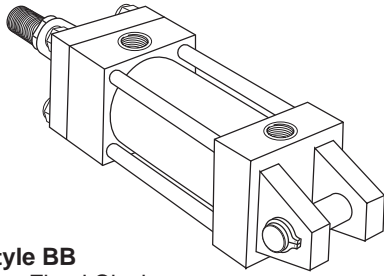
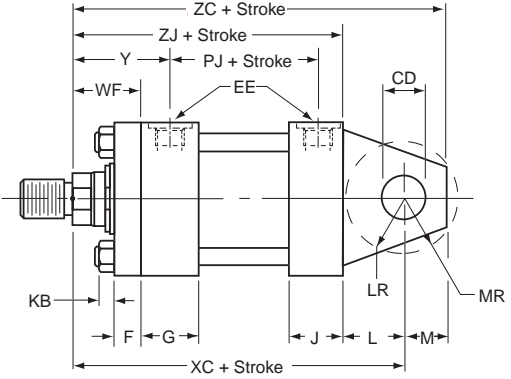
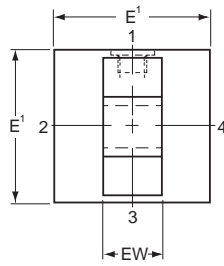

Style BB
Cap Fixed Clevis
(ISO Style MP1)

Supplied complete with pivot pin

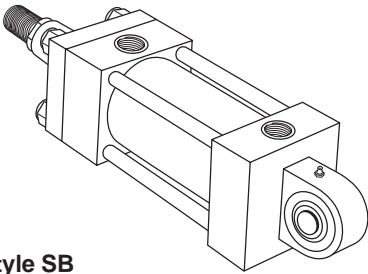
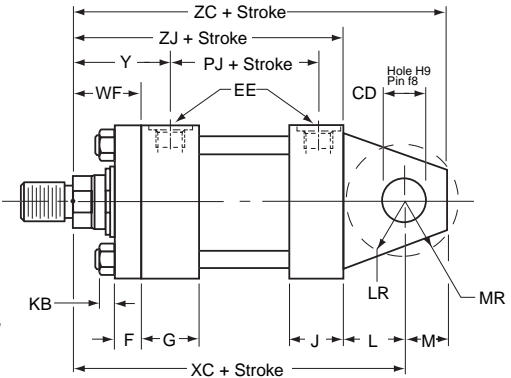
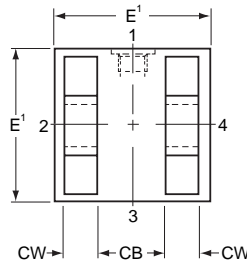

Style SB
Cap Fixed Eye
(ISO Style MP5)

Pivot pin not supplied

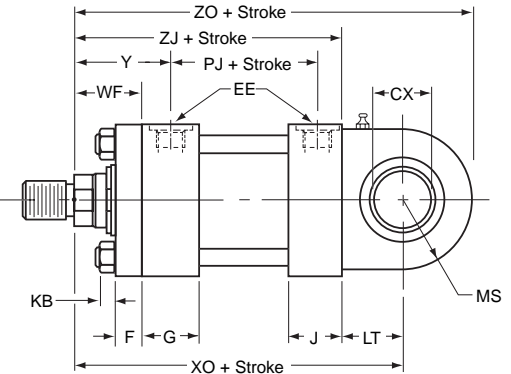
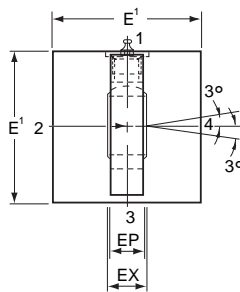

¹Head depth increased by 5mm to accommodate port on 25mm and 32mm bore cylinders – see 25 & 32mm Bore Head data page.

Dimensions – B, BB & SB See also Rod End Dimensions and Mounting Information.

Bore Ø	CB A16	CD H9	CW	CX	E	EE BSP/G inches	EP	EW h14	EX	F	G	J	KB	L	LR	LT	M	MR	MS max	WF	Y	+ Stroke					
																						PJ	XC	XO	ZC	ZJ	ZO
25	12	10	6	12-0.008	40 ¹	1/4	8	12	10	10	40	25	4	13	12	16	10	12	20	25	50	53	127	130	137	114	150
32	16	12	8	16-0.008	45 ¹	1/4	11	16	14	10	40	25	5	19	17	20	12	15	22.5	35	60	56	147	148	159	128	170.5
40	20	14	10	20-0.012	63	3/8	13	20	16	10	45	38	6.5	19	17	25	14	16	29	35	62	73	172	178	186	153	207
50	30	20	15	25-0.012	76	1/2	17	30	20	16	45	38	10	32	29	31	20	25	33	41	67	74	191	190	211	159	223
63	30	20	15	30-0.012	90	1/2	19	30	22	16	45	38	10	32	29	38	20	25	40	48	71	80	200	206	220	168	246
80	40	28	20	40-0.012	115	3/4	23	40	28	20	50	45	13	39	34	48	28	34	50	51	77	93	229	238	257	190	288
100	50	36	25	50-0.012	130	3/4	30	50	35	22	50	45	13	54	50	58	36	44	62	57	82	101	257	261	293	203	323
125	60	45	30	60-0.015	165	1	38	60	44	22	58	58	18	57	53	72	45	53	80	57	86	117	289	304	334	232	384
160	70	56	35	80-0.015	205	1	47	70	55	25	58	58	22	63	59	92	59	59	100	57	86	130	308	337	367	245	437
200	80	70	40	100-0.020	245	1-1/4	57	80	70	25	76	76	24	82	78	116	70	76	120	57	98	165	381	415	451	299	535

All dimensions are in millimeters unless otherwise stated.

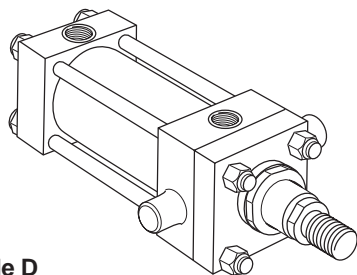

Style D
Head Trunnion
(ISO Style MT1)

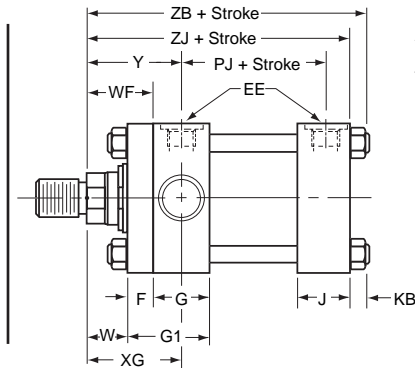

Notes:

A one-piece head and retainer is used on 100mm-200mm bore sizes – G1 dimension. On 160 and 200mm bores, the bolted gland is recessed, with tie rods screwed into the head.

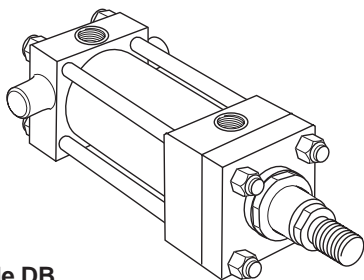
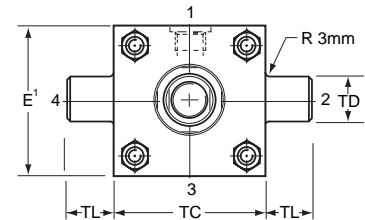

Style DB
Cap Trunnion
(ISO Style MT2)

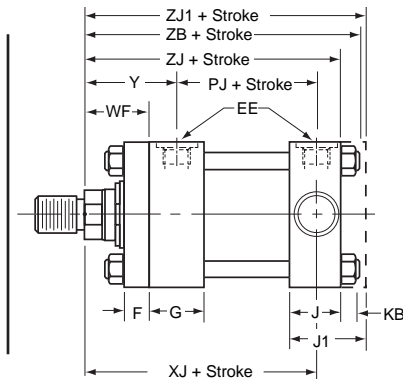

Note:

On 80-200mm bore cylinders, dimension J becomes J1. ZJ1 replaces ZB, and tie rods are screwed directly into the cap.

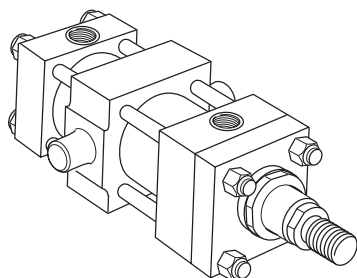
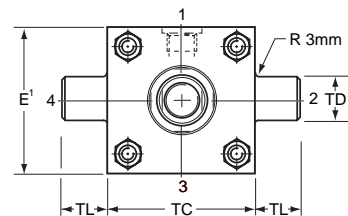

Style DD
Intermediate Fixed Trunnion
(ISO Style MT4)

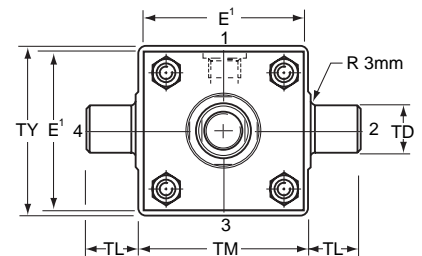
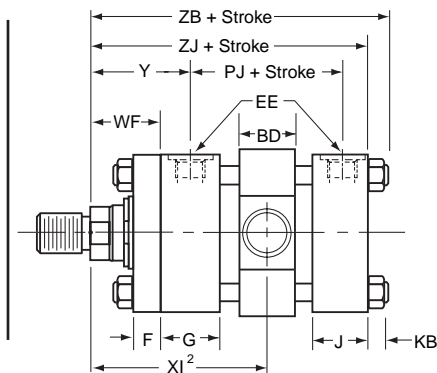

¹Head depth increased by 5mm to accommodate port on 25mm and 32mm bore cylinders – see 25 & 32mm Bore Head data page.

²Dimensions to be specified by customer. See table below for minimum XI dimensions and minimum cylinder stroke.

Dimensions – D, DB & DD See also Rod End Dimensions and Mounting Information.

Bore ø	BD	E	EE BSP/G inches	F	G	G1	J	J1	KB	TC	TD	TL	TM	TY	W	WF	XG	Y	+ Stroke					Style DD min stroke	Min XI dim'n
																			PJ	XJ	ZJ	ZJ1	ZB		
25	20	40 ¹	1/4	10	40	-	25	-	4	38	12	10	48	45	-	25	44	50	53	101	114	-	121	10	78
32	25	45 ¹	1/4	10	40	-	25	-	5	44	16	12	55	54	-	35	54	60	56	115	128	-	137	10	90
40	30	63	3/8	10	45	-	38	-	6.5	63	20	16	76	76	-	35	57	62	73	134	153	-	166	15	97
50	40	76	1/2	16	45	-	38	-	10	76	25	20	89	89	-	41	64	67	74	140	159	-	176	15	107
63	40	90	1/2	16	45	-	38	-	10	89	32	25	100	95	-	48	70	71	80	149	168	-	185	15	114
80	50	115	3/4	20	50	-	45	50	13	114	40	32	127	127	-	51	76	77	93	168	190	194	212	20	127
100	60	130	3/4	22	50	72	45	58	13	127	50	40	140	140	35	57	71	82	101	187	203	216	225	20	138
125	73	165	1	22	58	80	58	71	18	165	63	50	178	178	35	57	75	86	117	209	232	245	260	25	153
160	90	205	1	25	58	88	58	88	22	203	80	63	215	216	32	57	75	86	130	230	245	275	279	30	161
200	110	245	1-1/4	25	76	108	76	108	24	241	100	80	279	280	32	57	85	98	165	276	299	330	336	30	190

All dimensions are in millimeters unless otherwise stated.

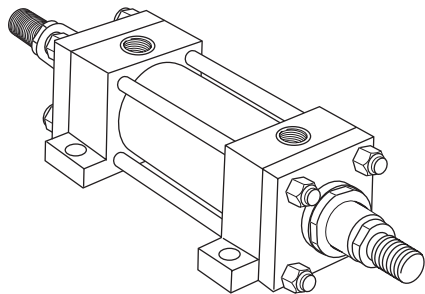

Double Rod Cylinder

Available with Styles TB, TD, JJ, C, D, DD (Style C illustrated)

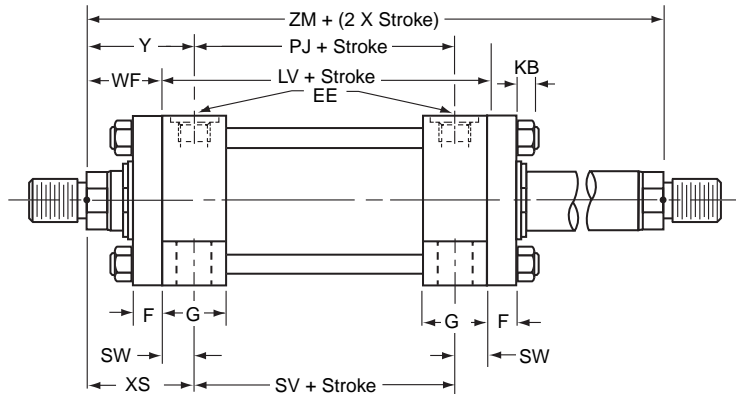

Mounting Styles and Codes

Double rod cylinders are denoted by a 'K' in the ISO cylinder model code.

Dimensions

To obtain dimensional information for double rod cylinders, first select the desired mounting style by referring to the corresponding single rod model. Dimensions for the appropriate single rod model should be supplemented by those from the table opposite to provide a full set of dimensions.

Minimum Stroke Length – Style 9 Rod End

Where a style 9 (female) piston rod end is required on a double rod cylinder with a stroke of 80mm or less, and a bore of 80mm or above, please consult the factory.

Cushioning

Double rod cylinders can be supplied with cushions at either or both ends. Cushioning requirements should be specified by inserting a 'C' in the ordering code. See How To Order page of this section.

Double Rod Cylinders

For double rod cylinders, specify rod number and rod end symbols for both piston rods. A typical model number for a double rod cylinder would be:

100	K	JJ	SHM	R	E	1	4	M	1	4	M	125	M	11	44
-----	---	----	-----	---	---	---	---	---	---	---	---	-----	---	----	----

Bore ø	Rod		Add Stroke			Add 2x Stroke
	No.	MM ø	LV	PJ	SV	ZM
25	1	12	104	53	88	154
	2	18				
32	1	14	108	56	88	178
	2	22				
40	1	18	125	73	105	195
	2	28				
50	1	22	125	74	99	207
	2	36				
	3	28				
63	1	28	127	80	93	223
	2	45				
	3	36				
80	1	36	144	93	110	246
	2	56				
	3	45				
100	1	45	151	101	107	265
	2	70				
	3	56				
125	1	56	175	117	131	289
	2	90				
	3	70				
160	1	70	188	130	130	302
	2	110				
	3	90				
200	1	90	242	160	172	356
	2	140				
	3	110				

All dimensions are in millimeters unless otherwise stated.

Accessory Selection

Accessories for the rod end of a cylinder are selected by reference to the rod end thread, while the same accessories, when used at the cap end, are selected by cylinder bore size. See tables of part numbers below, and on the following pages.

The rod clevises, plain rod eyes and spherical bearings fitted as accessories to the rod end have the same pin diameters as those used at the cylinder cap ends of the corresponding mounting styles – B, BB and SB – when fitted with the No. 1 rod, or the No. 2 or No. 3 rods with Style 7 rod end.

Rod and Cap End Accessories

Accessories for the SHM ISO cylinder include:

- Rod End** – rod clevis, eye bracket and pivot pin
 – plain rod eye, clevis bracket and pivot pin
 – rod eye with spherical bearing
- Cap End** – eye bracket for style BB mounting
 – clevis bracket for style B mounting
 – pivot pin for eye bracket and clevis bracket

Rod Clevis, Eye Bracket and Pivot Pin

Thread KK	Rod Clevis	Eye Bracket	Pivot Pin	Nominal Force kN	Weight kg
M10x1.25	143447	144808	143477	8	0.3
M12x1.25	143448	144809	143478	12.5	0.6
M14x1.5	143449	144810	143479	20	0.8
M16x1.5	143450	144811	143480	32	2.2
M20x1.5	143451	144812	143480	50	2.7
M27x2	143452	144813	143481	80	5.9
M33x2	143453	144814	143482	125	9.4
M42x2	143454	144815	143483	200	17.8
M48x2	143455	144816	143484	320	26.8
M64x3	143456	144817	143485	500	39.0

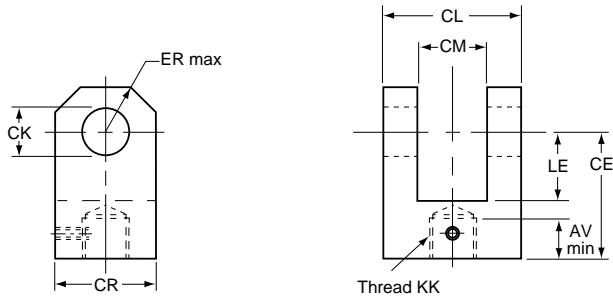

Rod Clevis

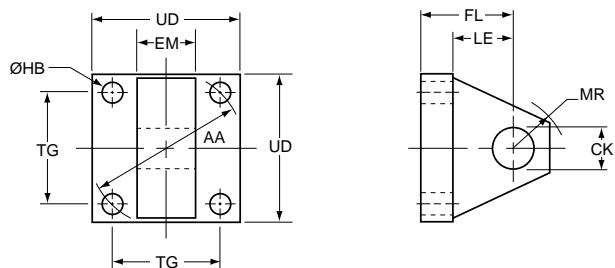

Eye Bracket

All dimensions are in millimeters unless otherwise stated.

Rod Clevis Dimensions

Part No.	AV	CE	CK H9	CL	CM A16	CR	ER	KK	LE	Weight kg
143447	14	32	10	26	12	20	12	M10x1.25	14	0.08
143448	16	36	12	34	16	32	17	M12x1.25	19	0.25
143449	18	38	14	42	20	30	17	M14x1.5	19	0.32
143450	22	54	20	62	30	50	29	M16x1.5	32	1.0
143451	28	60	20	62	30	50	29	M20x1.5	32	1.1
143452	36	75	28	83	40	60	34	M27x2	39	2.3
143453	45	99	36	103	50	80	50	M33x2	54	2.6
143454	56	113	45	123	60	102	53	M42x2	57	5.5
143455	63	126	56	143	70	112	59	M48x2	63	7.6
143456	85	168	70	163	80	146	78	M64x3	83	13.0

Eye Bracket Dimensions

Part No.	CK H9	EM h13	FL	MR max	LE min	AA	HB	TG	UD
144808	10	12	23	12	13	40	5.5	28.3	40
144809	12	16	29	17	19	47	6.6	33.2	45
144810	14	20	29	17	19	59	9	41.7	65
144811	20	30	48	29	32	74	13.5	52.3	75
144812	20	30	48	29	32	91	13.5	64.3	90
144813	28	40	59	34	39	117	17.5	82.7	115
144814	36	50	79	50	54	137	17.5	96.9	130
144815	45	60	87	53	57	178	26	125.9	165
144816	56	70	103	59	63	219	30	154.9	205
144817	70	80	132	78	82	269	33	190.2	240

Pivot Pin for Clevis Bracket and Plain Rod Eye – Dimensions

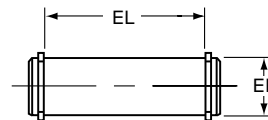

Part No.	EK f8	EL	Weight kg
143477	10	29	0.02
143478	12	37	0.05
143479	14	45	0.08
143480	20	66	0.2
143481	28	87	0.4
143482	36	107	1.0
143483	45	129	1.8
143484	56	149	4.2
143485	70	169	6.0

Eye Bracket – Cap End Mounting for Style BB

Bore ϕ	Eye Bracket	Nominal Force kN	Weight kg
25	144808	8	0.2
32	144809	12.5	0.3
40	144810	20	0.4
50	144811	32	1.0
63	144812	50	1.4
80	144813	80	3.2
100	144814	125	5.6
125	144815	200	10.5
160	144816	320	15.0
200	144817	500	20.0

Plain Rod Eye, Clevis Bracket and Pivot Pin

Thread KK	Plain Rod Eye	Clevis Bracket	Pivot Pin	Nominal Force kN	Weight kg
M10x1.25	143457	143646	143477	8	0.5
M12x1.25	143458	143647	143478	12.5	1.0
M14x1.5	143459	143648	143479	20	1.3
M16x1.5	143460	143649	143480	32	3.2
M20x1.5	143461	143649	143480	50	3.8
M27x2	143462	143650	143481	80	6.9
M33x2	143463	143651	143482	125	12.5
M42x2	143464	143652	143483	200	26.0
M48x2	143465	143653	143484	320	47.0
M64x3	143466	143654	143485	500	64.0

Plain Rod Eye/Knuckle Dimensions

Part No.	AW	CA	CB	CD	CK H9	EM h13	ER	KK	LE	Weight kg
143457	14	32	18	9	10	12	12	M10x1.25	13	0.08
143458	16	36	22	11	12	16	17	M12x1.25	19	0.15
143459	18	38	20	12.5	14	20	17	M14x1.5	19	0.22
143460	22	54	30	17.5	20	30	29	M16x1.5	32	0.5
143461	28	60	30	20	20	30	29	M20x1.5	32	1.1
143462	36	75	40	25	28	40	34	M27x2	39	1.5
143463	45	99	50	35	36	50	50	M33x2	54	2.5
143464	56	113	65	50	45	60	53	M42x2	57	4.2
143465	63	126	90	56	56	70	59	M48x2	63	11.8
143466	85	168	110	70	70	80	78	M64x3	83	17.0

Clevis Bracket Dimensions

Part No.	CK H9	CM A16	CW	FL	MR max	HB	LE min	RC	TB	UR	UH
143646	10	12	6	23	12	5.5	13	18	47	35	60
143647	12	16	8	29	17	6.6	19	24	57	45	70
143648	14	20	10	29	17	9	19	30	68	55	85
143649	20	30	15	48	29	13.5	32	45	102	80	125
143650	28	40	20	59	34	17.5	39	60	135	100	170
143651	36	50	25	79	50	17.5	54	75	167	130	200
143652	45	60	30	87	53	26	57	90	183	150	230
143653	56	70	35	103	59	30	63	105	242	180	300
143654	70	80	40	132	78	33	82	120	300	200	360

Clevis Bracket – For Style B

Bore ø	Clevis Bracket	Nominal Force kN	Weight kg
25	143646	8	0.4
32	143647	12.5	0.8
40	143648	20	1.0
50	143649	32	2.5
63	143649	50	2.5
80	143650	80	5.0
100	143651	125	9.0
125	143652	200	20.0
160	143653	320	31.0
200	143654	500	41.0

Plain Rod Eye/Knuckle

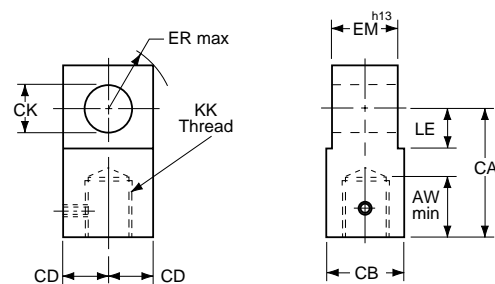

Clevis Bracket

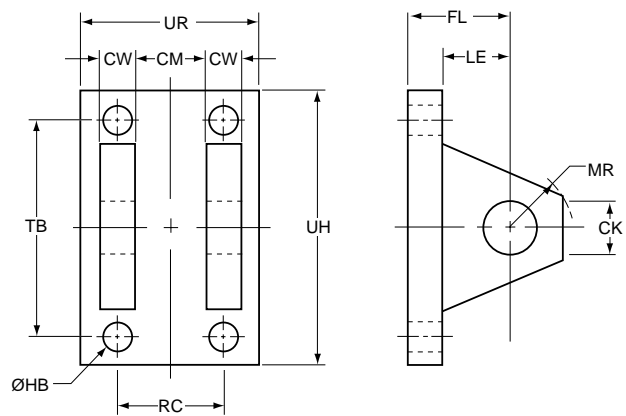

Pivot Pin for Clevis Bracket and Plain Rod Eye – Dimensions

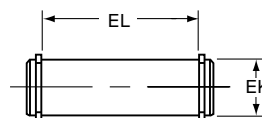

Part No.	EK f8	EL	Weight kg
143477	10	29	0.02
143478	12	37	0.05
143479	14	45	0.08
143480	20	66	0.2
143481	28	87	0.4
143482	36	107	1.0
143483	45	129	1.8
143484	56	149	4.2
143485	70	169	6.0

All dimensions are in millimeters unless otherwise stated.

**Rod Eye with Spherical Bearing,
 Mounting Bracket and Pivot Pin**

Thread KK	Rod Eye with Spherical Bearing	Mounting Bracket and Pivot Pin	Nominal Force kN	Weight kg
M10x1.25	145254	145530	8	0.2
M12x1.25	145255	145531	12.5	0.3
M14x1.5	145256	145532	20	0.4
M16x1.5	145257	145533	32	0.7
M20x1.5	145258	145534	50	1.3
M27x2	145259	145535	80	2.3
M33x2	145260	145536	125	4.4
M42x2	145261	145537	200	8.4
M48x2	145262	145538	320	15.6
M64x3	145263	145539	500	28.0

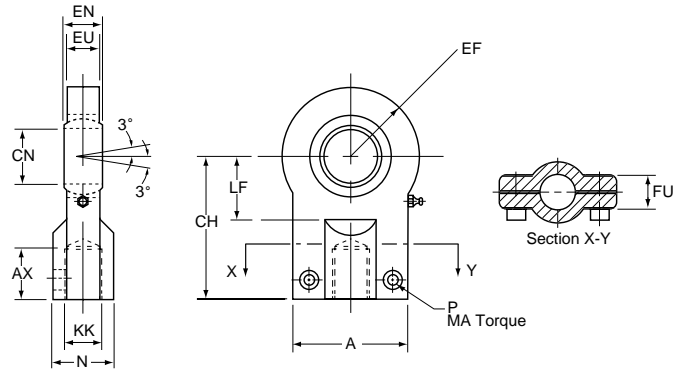

Rod Eye with Spherical Bearing

All spherical bearings should be re-packed with grease when servicing. In unusual or severe working conditions, consult the factory regarding the suitability of the bearing chosen.

Rod Eye with Spherical Bearing Dimensions

Part No.	A max	AX min	EF max	CH	CN	EN	EU	FU	KK	LF min	N max	MA max Nm	P
145254	40	15	20	42	12 -0.008	10 -0.012	8	13	M10x1.25	16	17	10	M6
145255	45	17	22.5	48	16 -0.008	14 -0.012	11	13	M12x1.25	20	21	10	M6
145256	55	19	27.5	58	20 -0.012	16 -0.012	13	17	M14x1.5	25	25	25	M8
145257	62	23	32.5	68	25 -0.012	20 -0.012	17	17	M16x1.5	30	30	25	M8
145258	80	29	40	85	30 -0.012	22 -0.012	19	19	M20x1.5	35	36	45	M10
145259	90	37	50	105	40 -0.012	28 -0.012	23	23	M27x2	45	45	45	M10
145260	105	46	62.5	130	50 -0.012	35 -0.012	30	30	M33x2	58	55	80	M12
145261	134	57	80	150	60 -0.015	44 -0.015	38	38	M42x2	68	68	160	M16
145262	156	64	102.5	185	80 -0.015	55 -0.015	47	47	M48x2	92	90	310	M20
145263	190	86	120	240	100 -0.020	70 -0.020	57	57	M64x3	116	110	530	M24

Mounting Bracket and Pivot Pin Dimensions - For Style SB

Part No.	CF K7/h6	CG +0.1, +0.3	CO N9	CP	FM js11	FO js14	GL js13	HB	KC 0, +0.30	LG	LJ	LO	RE js13	SR max	TA js13	UJ	UK
145530	12	10	10	30	40	16	46	9	3.3	28	29	56	55	12	40	75	60
145531	16	14	16	40	50	18	61	11	4.3	37	38	74	70	16	55	95	80
145532	20	16	16	50	55	20	64	14	4.3	39	40	80	85	20	58	120	90
145533	25	20	25	60	65	22	78	16	5.4	48	49	98	100	25	70	140	110
145534	30	22	25	70	85	24	97	18	5.4	62	63	120	115	30	90	160	135
145535	40	28	36	80	100	24	123	22	8.4	72	73	148	135	40	120	190	170
145536	50	35	36	100	125	35	155	30	8.4	90	92	190	170	50	145	240	215
145537	60	44	50	120	150	35	187	39	11.4	108	110	225	200	60	185	270	260
145538	80	55	50	160	190	35	255	45	11.4	140	142	295	240	80	260	320	340
145539	100	70	63	200	210	35	285	48	12.4	150	152	335	300	100	300	400	400

Cap Mounting Bracket and Pivot Pin

Bore ϕ	Mounting Bracket and Pivot Pin	Nominal Force kN	Weight kg
25	145530	8	0.6
32	145531	12.5	1.3
40	145532	20	2.1
50	145533	32	3.2
63	145534	50	6.5
80	145535	80	12.0
100	145536	125	23.0
125	145537	200	37.0
160	145538	320	79.0
200	145539	500	140.0

Mounting Bracket and Pivot Pin

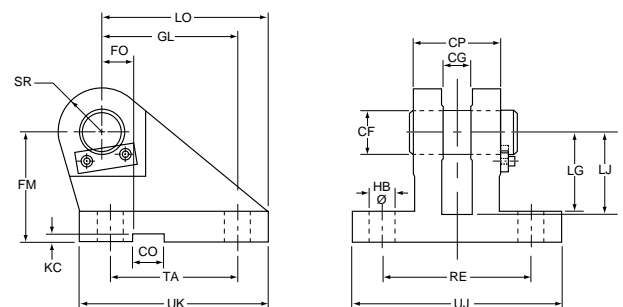

All dimensions are in millimeters unless otherwise stated.

How to Order ISO Cylinders

Data Required On All Cylinder Orders

When ordering SHM Series cylinders, be sure to specify each of the following requirements:

(NOTE: – Duplicate cylinders can be ordered by giving the SERIAL NUMBER from the nameplate of the original cylinder. Factory records supply a quick, positive identification.)

a) Bore Size

b) Mounting Style

Specify your choice of mounting style – as shown and dimensioned in this catalog. If double rod is required, specify “with double rod.”

c) Series Designation (“SHM”)

d) Length of Stroke

e) Piston Rod Diameter

Call out rod diameter or rod code number. In SHM Series cylinders, standard rod diameters (Code No. 1) will be furnished if not otherwise specified, unless length of stroke makes the application questionable.

f) Piston Rod End Thread Style

Call out thread style number or specify dimensions. Thread style number 4 will be furnished if not otherwise specified.

g) Cushions (if required)

Specify “Cushion-head end,” “Cushion-cap end” or “Cushion-both ends” as required. If cylinder is to have a double rod and only one cushion is required, be sure to specify clearly which end of the cylinder is to be cushioned.

h) Piston

Schrader Bellows B style pistons are standard. Fluorocarbon also available.

i) Ports

BSP (ISO 228) are standard.

j) Fluid Medium

SHM Series hydraulic cylinders are equipped with seals for use with hydraulic oil. If other than hydraulic oil will be used, consult factory.

ADDITIONAL DATA is required on orders for cylinders with special modifications.
For further information, consult factory.

Service Policy

On cylinders returned to the factory for repairs, it is standard policy for the Industrial Cylinder Division to make such part replacements as will put the cylinder in as good as new condition. Should the condition of the returned cylinder be such that expenses for repair would exceed the costs of a new one, you will be notified.

Address all correspondence to Service Department at your nearest regional plant listed in the pages of this catalog.

SHM Series Model Numbers – How to Develop and “Decode” Them

Schrader Bellows SHM Series cylinders can be completely and accurately described by a model number consisting of coded symbols. For single rod cylinders a maximum of 17 places for digits and letters are used in a prescribed sequence to produce a model number. Only twelve places are needed

to completely describe a standard noncushioned SHM Series cylinder. To develop a model number, select only those symbols that represent the cylinder required, and place them in the sequence indicated below.

Feature	Description	Symbol	Example																
			80	C	K	C	K	SHM	R	B	S	1	4	M	C	230	M	11	44
Bore	Millimeters	–	●	○	○	○	○	○	○	○	○	○	○	○	○	○	○	○	
Cushion – Head	If required	C	○	○	○	○	○	○	○	○	○	○	○	○	○	○	○	○	
Double Rod	If required	K	○	○	○	○	○	○	○	○	○	○	○	○	○	○	○	○	
Mounting Style	Head Tie Rods Extended	TB	○	○	○	○	○	○	○	○	○	○	○	○	○	○	○	○	
	Cap Tie Rods Extended	TC	○	○	○	○	○	○	○	○	○	○	○	○	○	○	○	○	
	Both Ends Tie Rods Extended	TD	○	○	○	○	○	○	○	○	○	○	○	○	○	○	○	○	
	Head Rectangular	JJ	○	○	○	○	○	○	○	○	○	○	○	○	○	○	○	○	
	Cap Rectangular	HH	○	○	○	○	○	○	○	○	○	○	○	○	○	○	○	○	
	Side Lugs	C	○	○	○	○	○	○	○	○	○	○	○	○	○	○	○	○	
	Cap Fixed Eye	B	○	○	○	○	○	○	○	○	○	○	○	○	○	○	○	○	
	Cap Fixed Clevis	BB	○	○	○	○	○	○	○	○	○	○	○	○	○	○	○	○	
	Spherical Bearing	SB	○	○	○	○	○	○	○	○	○	○	○	○	○	○	○	○	
	Head Trunnion	D	○	○	○	○	○	○	○	○	○	○	○	○	○	○	○	○	
	Cap Trunnion	DB	○	○	○	○	○	○	○	○	○	○	○	○	○	○	○	○	
	Intermediate Fixed Trunnion†	DD	○	○	○	○	○	○	○	○	○	○	○	○	○	○	○	○	
Mounting Modifications	Thrust key for Style C mounting only	P	○	○	○	○	○	○	○	○	○	○	○	○	○	○	○	○	
	– Thrust key - 25mm & 32mm bores – Thrust key - 40mm bore and larger	K	○	○	○	○	○	○	○	○	○	○	○	○	○	○	○	○	
Series	Series name	SHM	○	○	○	○	○	○	○	○	○	○	○	○	○	○	○		
Ports	BSP (ISO 228) – standard	R	○	○	○	○	○	○	○	○	○	○	○	○	○	○	○	○	
	BSPT (Taper Thread)	B	○	○	○	○	○	○	○	○	○	○	○	○	○	○	○	○	
	Metric Thread	M	○	○	○	○	○	○	○	○	○	○	○	○	○	○	○	○	
	Metric Thread per ISO 6149	Y	○	○	○	○	○	○	○	○	○	○	○	○	○	○	○	○	
	SAE – Straight Thread O-ring Port	T	○	○	○	○	○	○	○	○	○	○	○	○	○	○	○	○	
	NPTF (Dry Seal Pipe Thread)	U	○	○	○	○	○	○	○	○	○	○	○	○	○	○	○	○	
Piston	SAE – Flange Ports (3000 PSI)	P	○	○	○	○	○	○	○	○	○	○	○	○	○	○	○	○	
	Lipseal™ Piston* (standard 25mm - 40mm bores)	L	○	○	○	○	○	○	○	○	○	○	○	○	○	○	○	○	
	B-Style Low Friction filled PTFE seals (standard 50mm - 200mm bores)	B	○	○	○	○	○	○	○	○	○	○	○	○	○	○	○	○	
Special Features	Mixed Media Low Friction Piston Seal (optional 25mm - 200mm bores)	W	○	○	○	○	○	○	○	○	○	○	○	○	○	○	○	○	
	One or more of the following: Gland Drain Port Oversize Ports Rod End Bellows Stop Tube Stroke Adjuster Tie Rod Supports Water Service Modifications Or to detailed descriptions or drawings supplied by customer	S	○	○	○	○	○	○	○	○	○	○	○	○	○	○	○	○	
			○	○	○	○	○	○	○	○	○	○	○	○	○	○	○	○	
Piston Rod Number	Rod No. 1	1	○	○	○	○	○	○	○	○	○	○	○	○	○	○	○	○	
	Rod No. 2	2	○	○	○	○	○	○	○	○	○	○	○	○	○	○	○	○	
	Rod No. 3	3	○	○	○	○	○	○	○	○	○	○	○	○	○	○	○	○	
Piston Rod End	Style 4	4	○	○	○	○	○	○	○	○	○	○	○	○	○	○	○	○	
	Style 7	7	○	○	○	○	○	○	○	○	○	○	○	○	○	○	○	○	
	Style 9	9	○	○	○	○	○	○	○	○	○	○	○	○	○	○	○	○	
	Style 3 (Special) Please supply description or drawing	3	○	○	○	○	○	○	○	○	○	○	○	○	○	○	○	○	
Rod Thread	Metric (standard)	M	○	○	○	○	○	○	○	○	○	○	○	○	○	○	○		
Cushion – Cap	If required	C	○	○	○	○	○	○	○	○	○	○	○	○	○	○	○		
Gross Stroke	Millimeters	–	○	○	○	○	○	○	○	○	○	○	○	○	○	○	○		
Fluid Medium ISO 6743/4 (1982)	Mineral Oil HH, HL, HLP, – Group 1 HLP-D, HM, HV, MIL-H-5606 Oil, Air, Nitrogen	M	○	○	○	○	○	○	○	○	○	○	○	○	○	○	○	○	
	Fluorocarbon – Group 5	D	○	○	○	○	○	○	○	○	○	○	○	○	○	○	○	○	
Port Positions	Head position 1-4	1	○	○	○	○	○	○	○	○	○	○	○	○	○	○	○	○	
	Cap position 1-4	1	○	○	○	○	○	○	○	○	○	○	○	○	○	○	○	○	
Air Bleeds	Head position 1-4	4	○	○	○	○	○	○	○	○	○	○	○	○	○	○	○	○	
	Cap position 1-4	4	○	○	○	○	○	○	○	○	○	○	○	○	○	○	○	○	
	No Air Bleed	00	○	○	○	○	○	○	○	○	○	○	○	○	○	○	○	○	

Key: ● Essential information
 ○ Optional features

*Lipseal piston not available 50mm - 200mm bores. Contact factory regarding B-style piston availability in 25mm - 40mm bores.

†Specify XI dimension.



NOTES