

Datasheet - BN 310-RZ

Magnetic reed switch / BN 310

 Preferred typ

(Minor differences between the printed image and the original product may exist!)

- Non-contact principle
- 1 Reed kontakts
- Actuation from side
- Flat design
- Actuating surface and direction of actuation marked by switch symbol
- 88 mm x 25 mm x 13 mm
- Thermoplastic enclosure
- Actuating distance up to 60 mm depending on actuating magnet and version

Ordering details

Product type description	BN 310-RZ
Article number	101133843
EAN code	4030661059426

Approval

Approval



Global Properties

Product name	BN 310
Standards	-
Compliance with the Directives (Y/N) 	Yes
suitable for elevators (Y/N)	Yes
Mounting	Enclosure with mounting slots
Active principle	Magnetic drive
Materials	
- Material of the housings	Plastic, glass-fibre reinforced thermoplastic
- Material of the cable mantle	H03VV-F
Housing construction form	rectangular, flat
Weight	65 g
Recommended actuator	BP 10 N, BP 10 S, 2 x BP 10 N, 2 x BP 10 S, BP 15 N, BP 15 S, 2 x BP 15/2 N, 2 x BP 15/2 S, BP 34 N, BP 34 S, BP 20 N, BP 20 S, BP 31 N, BP 31 S, BP 11 N, BP 11 S, 2 x BP 11 N, 2 x BP 11 S, BP 12 N, BP 12 S, 2 x BP 12 N, 2 x BP 12 S, BP 21 N, BP 21 S, 2 x BP 21 N, 2 x BP 21 S, BE 20 N(S) ST 24VDC, BE 20 N(S) 48VDC
- Lift switchgear	BP 10, 2 x BP 10, 2 x BP 15/2, BP 15, 2 x BP 15, BP 34

Mechanical data

Design of electrical connection	Cable
Cable length	1 m
Conductors	2 x 0,75 mm ²

AWG-Number	18
Mechanical life	1.000.000.e+9 operations
Electrical lifetime	1.000.000 ... 1.000.000.e+9 operations
Actuating planes	Actuation from side
Switch distance S _n	5 mm ... 60 mm BP 10N = 15 mm BP 10S = 15 mm 2 x BP 10N = 20 mm 2 x BP 10S = 20 mm BP 15N = 17 mm BP 15S = 17 mm 2 x BP 15/2N = 22 mm 2 x BP 15/2S = 22 mm BP 34N = 15 ... 30 mm BP 34S = 15 ... 30 mm BP 20N = 3 ... 25 mm BP 20S = 3 ... 25 mm BP 31N = 3 ... 25 mm BP 31S = 3 ... 25 mm BP 11N = 15 mm BP 11S = 15 mm 2 x BP 11N = 3 ... 25 mm 2 x BP 11S = 3 ... 25 mm BP 12N = 20 mm BP 12S = 20 mm 2 x BP 12N = 10 ... 30 mm 2 x BP 12S = 10 ... 30 mm BP 21N = 15 ... 45 mm BP 21S = 15 ... 45 mm 2 x BP 21N = 20 ... 60 mm 2 x BP 21S = 20 ... 60 mm BE 20N = 20 mm BE 20S = 20 mm
- notice	Actuating distance up to 60 mm depending on actuating magnet and version The specifications with regard to the switching distances apply to the actuation of the individually mounted devices without ferromagnetic influence. Any change of the distance, positive either negative, is possible due to ferromagnetic interference. When multiple actuating magnets are used, the mutual interference must be observed.
Type of actuation	Magnet
restistance to shock	30 g / 11 ms
Resistance to vibration	10 ... 55 Hz, Amplitude 1 mm
Bounce duration	0,3 ms ... 0,6 ms
Latching (Y/N)	Yes
Actuating speed	max. 18 m/s
Switching point accuracy	± 0,25 mm

Ambient conditions

Ambient temperature	
- Min. environmental temperature	-25 °C
- Max. environmental temperature	+75 °C
Protection class	IP67 to IEC/EN 60529

Electrical data

Design of control element	bistable contact
Number of snap-in contacts	1
Switching time - Close	0,3 ms ... 1.5 ms
Switching time - Open	max. 0,5 ms

Switch frequency	< 300 Hz
Dielectric strength	> 600 VAC (50 Hz)
Switching voltage	max. 250 VAC/DC
Switching current	max. 3 A
Switching capacity	max. 120 VA / W

Outputs

Design of control output	Reed kontakts
--------------------------	---------------

LED switching conditions display

LED switching conditions display (Y/N)	No
--	----

ATEX

Explosion protection categories for gases	None
Explosion protected category for dusts	None

Dimensions

Dimensions of the sensor	
- Width of sensor	88 mm
- Height of sensor	25 mm
- Length of sensor	13 mm

notice

The opening and closing functions depend on the direction of actuation, the actuating magnets and the polarity of the actuating magnets.

When the switches and actuators come together, the colours must coincide: Red (S) to red (S) and green (N) to green (N). This does not apply to the bistable contact.

The switch is to be mounted on iron with a non-magnetic layer of at least 20 mm.

Included in delivery

Actuators must be ordered separately.

Diagram

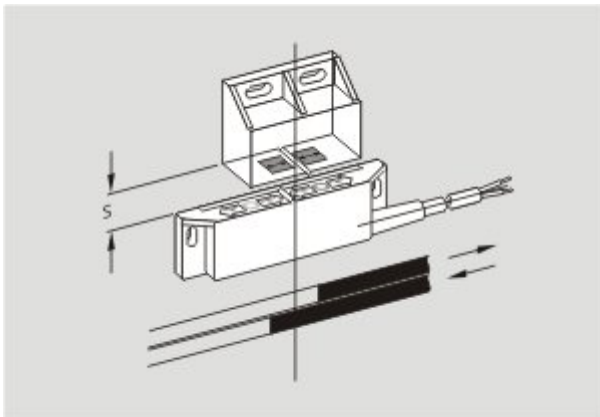

Note Diagram

⊖ positive break NC contact

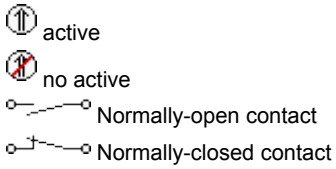

Switch travel diagram



Notes Switch travel diagram

- Contact closed
- Contact open
- Setting range
- Break point
- Positive opening sequence/- angle
- VS** adjustable range of NO contact
- VÖ** adjustable range of NC contact
- N** after travel

Ordering suffix

The applicable ordering suffix is added at the end of the part number of the safety switch.
Order example: BN 310-RZ-**2M**

...-**2M**

...-**3M**

...-**5M** Cable length 5 Meter

Documents

Mounting and wiring instructions (de, en, fr) 91 kB, 03.01.2008
Code: m_bn3p01

Declaration of conformity (en) 118 kB, 26.02.2014
Code: __bn_p01_en

Declaration of conformity (de) 188 kB, 10.07.2012
Code: __bn_p01

notice - Switch distance (de) 36 kB, 07.08.2009
Code: s_bnbsp01

notice - Switch distance (nl) 39 kB, 07.08.2009
Code: s_bnbsp04

notice - Switch distance (en) 42 kB, 07.08.2009
Code: s_bnbsp02

notice - Switch distance (fr) 41 kB, 07.08.2009

Code: s_bnbsp03

notice - Switch distance (pt) 39 kB, 07.08.2009

Code: s_bnbsp10

notice - Switch distance (it) 40 kB, 07.08.2009

Code: s_bnbsp05

notice - Switch distance (es) 38 kB, 07.08.2009

Code: s_bnbsp09

Images

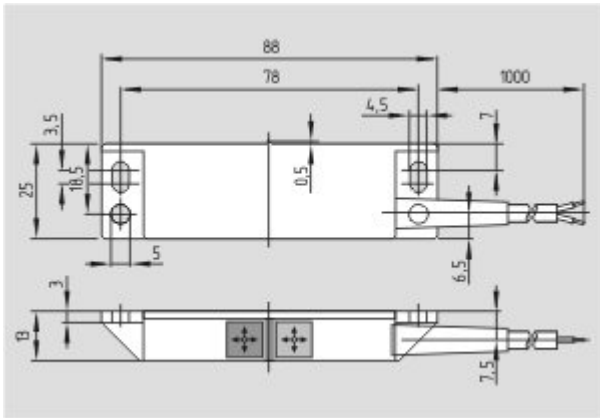

Dimensional drawing (basic component)

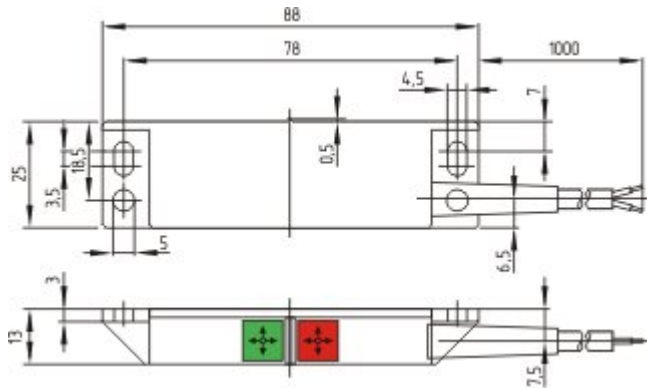

Dimensional drawing (basic component)



Switch travel diagram

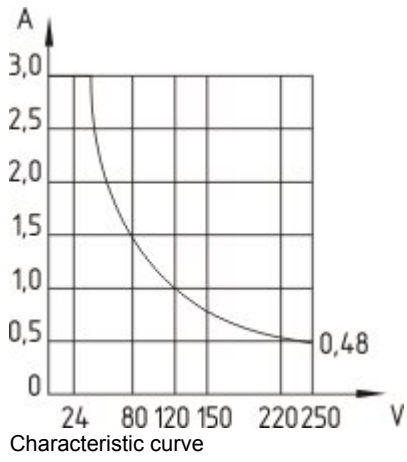

K.A. Schmersal GmbH & Co. KG, Möddinghofe 30, D-42279 Wuppertal

The data and values have been checked thoroughly. Technical modifications and errors excepted.

Generiert am 19.08.2014 - 01:34:49h Kasbase 2.2.18.F DBI

