

Parallel Grippers - Low Profile Series

- **Precision applications:**

Preloaded "Dual-V" roller bearings eliminate side play for excellent part position repeatability.

- **Repeatable grip force:**

Low friction mechanism allows for consistent, repeatable gripping forces. To grip delicate parts, grip force can be easily altered by adjusting air pressure.

- **Longer finger applications:**

Rigid design allows for longer gripper finger lengths to be used when compared to other grippers of equal weight & size.

- **Non-synchronous motion:**

The unit can be made non-synchronous providing independent jaw motion allowing the gripper to pick or place at a point other than it's center.

Mounting Information:

Grippers can be mounted & operated in any orientation

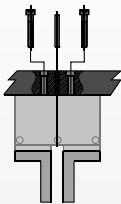

Body mounts with screws and locates with slip fit dowel pins for accuracy



Warning! Protect drive and bearing mechanism from falling debris when mounted upside down

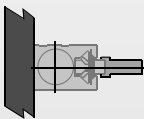

Fingers attach to jaws with screws and locate by keying

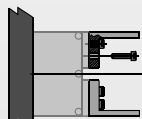

Technical Specifications:

Pneumatic Specifications

Pressure Operating Range
Cylinder Type
Dynamic Seals
Valve Required to Operate

Imperial	Metric
5-100 psi	.3-7 bar
Dual Double Acting	
Internally Lubricated Buna-N	
4-way, 2-position	

Air Quality Requirements

Air Filtration
Air Lubrication
Air Humidity

40 Micron or Better
Not Necessary*
Low Moisture Content (dry)

Temperature Operating Range

Buna-N Seals (standard)	-30°~180° F	-35°~80° C
Viton® Seals (optional)	-20°~250° F	-30°~120° C

Maintenance Specifications†

Expected Life	5 million cycles
Normal Application	10+ million cycles*
w/ Preventative Maintenance	Yes
Field Repairable	Yes
Seal Repair Kits Available	Yes

Application Restrictions

- Dirty or gritty environments
- Machining operations generating chips
- Environments with loose particulate
- Applications where mechanism lubricant could cause contamination

*Addition of lubrication will greatly increase service life
† See Maintenance Section

Product Features

Pre-Load Adjustment Screws

Adjustable preload screws allow for adjustment of preload on roller bearings

Hard Coat Anodize

The body has hard-coat anodize 60 RC with Teflon® impregnation

Self Lubricating Seals

Self lubricating dynamic seals (Buna-N only)

Quality Components

Internal components are made from hardened bearing & tool steels

One Piece Body

One piece lightweight aluminum body

Dowel Holes

Slip fit dowel pin holes in body

Accessory Mounting Bracket

Sensors

Reads position of jaw (Sold Separately- See "How to Order" Section for more info)

Preloaded Bearings

Roller bearings are preloaded for maximum support and zero side play

High Grip Force

High grip force with respect to weight due to extremely efficient drive mechanism

Non-Synchronous Operation Available

Patented Bearing Support

"Dual-V" roller bearings provide low friction rolling motion

Operating Principle

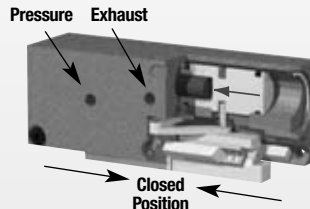
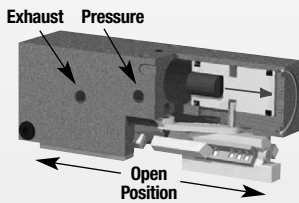
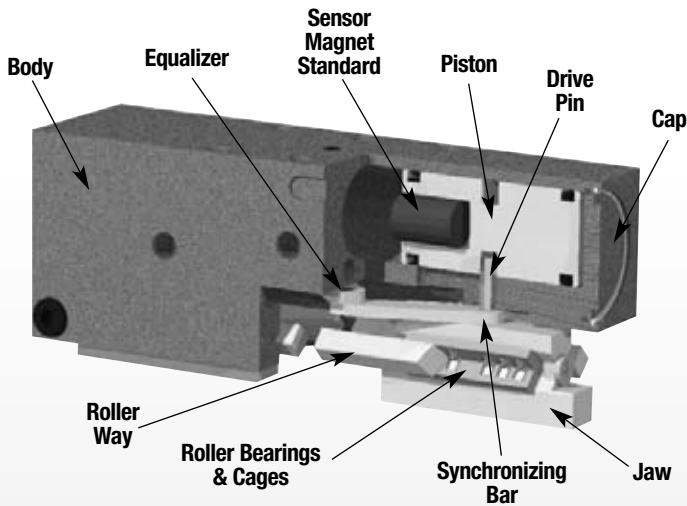

- Dual double acting opposed pistons, connected to both a jaw and a synchronizing bar by a drive pin, actuate in opposite directions.
- The synchronizing bars are connected to the equalizer which synchronizes the motion.
- Suitable for internal or external gripping.
- The synchronizing elements can be removed for non-synchronous operation.

U.S. Patent # 5,529,359

Designed and manufactured in the USA

Style-RPL Parallel Gripper

Size -1M

Style:	RPL-1	RPL-1M
Stroke:	0.25 in.	6.4 mm
Grip Force:	26 lbs.	116 N
Weight:	.16 lbs.	.07 Kg



See Page **1.92**

Style-RPL Parallel Gripper

Size -2M

Style:	RPL-2	RPL-2M
Stroke:	0.50 in.	12.7 mm
Grip Force:	26 lbs.	116 N
Weight:	.20 lbs.	.09 Kg



See Page **1.93**

Style-RPL Parallel Gripper

Size -3M

Style:	RPL-3	RPL-3M
Stroke:	0.75 in.	19.1 mm
Grip Force:	36 lbs.	160 N
Weight:	.32 lbs.	.14 Kg



See Page **1.94**

Style-RPL Parallel Gripper

Size -4M

Style:	RPL-4	RPL-4M
Stroke:	1.00 in.	25.4 mm
Grip Force:	36 lbs.	160 N
Weight:	.38 lbs.	.17 Kg



See Page **1.95**

PARALLEL GRIPPER RPL-1M PRECISION DUAL "V" LOW PROFILE SERIES

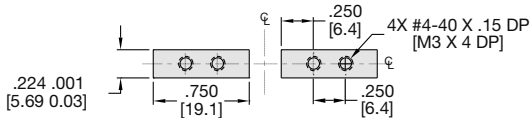
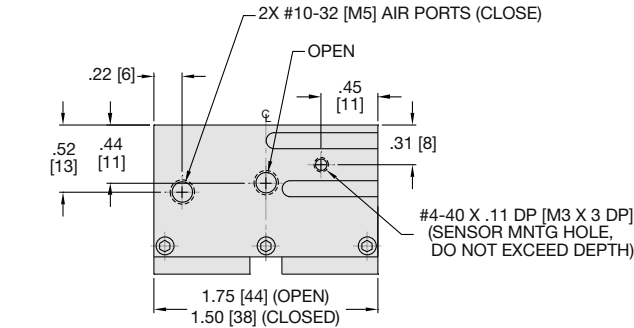
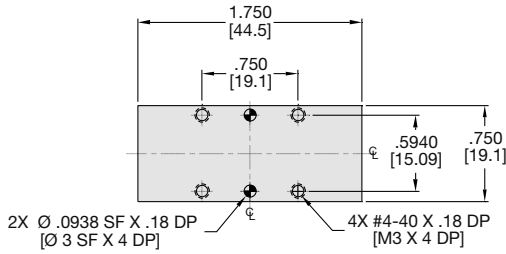

JAW MOUNTING PATTERN
(SHOWN IN OPEN POSITION)

Specifications

	RPL-1	RPL-1M
Total Rated Grip Force F @ 100 psi, 7 bar	26 lbs.	116 N
Stroke	0.25 in.	6.4 mm
Weight	0.16 lbs.	0.07 Kg
Pressure Range	5-100 psi	0.3-7 bar
Cylinder Bore Ø	0.438 in.	11.1 mm
Displacement	0.038 in ³	0.6 cm ³
Temperature Range		
Standard Seals	-30°~180° F	-35°~80° C
Viton® Seals	-20°~250° F	-30°~120° C
Actuation	0.10 sec.	0.10 sec.
Accuracy	±0.002 in.	±0.05 mm
Repeatability	±0.001 in.	±0.03 mm
Valve required to actuate	4-way, 2-position	

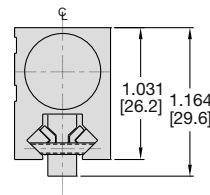

UNLESS OTHERWISE NOTED ALL TOLERANCES ARE AS SHOWN BELOW

	Imperial in.	Metric [mm]
Dimensions are symmetrical about centerline	0.00 ± .01	[0.] = [±.25]
Third Angle Projection	0.000 ± .005	[0.0] = [±.13]
All Dowel Holes are SF (Slip Fit). Locational Tolerance ±.0005" or [±.013mm]	0.0000 ± .0005	[0.00] = [±.013]
Metric Threads Course Pitch		

Loading Information

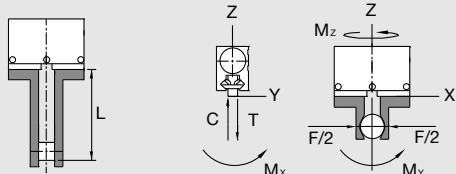
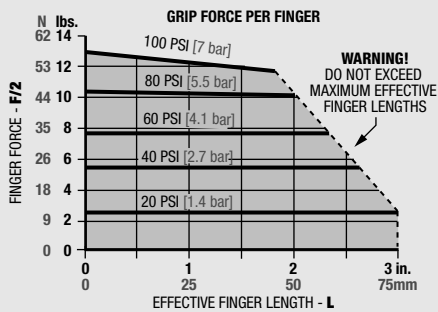

Loading Capacity†

	Static		Dynamic	
	Imperial	Metric	Imperial	Metric
Maximum Tensile T	50 lbs.	222 N	15 lbs.	67 N
Maximum Compressive C	50 lbs.	222 N	15 lbs.	67 N
Maximum Moment M_x	30 in.-lbs.	3.4 Nm	10 in.-lbs.	1.1 Nm
Maximum Moment M_y	40 in.-lbs.	4.5 Nm	12 in.-lbs.	1.4 Nm
Maximum Moment M_z	30 in.-lbs.	3.4 Nm	10 in.-lbs.	1.1 Nm

†Capacities are per set of jaws and are not simultaneous

How to Order: (Order Accessories separately from Basic Model)

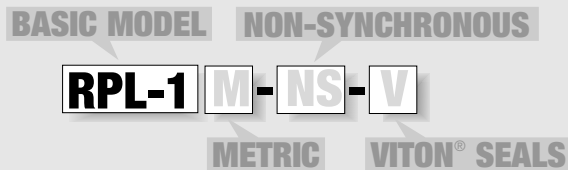

SENSOR ACCESSORIES*†

	ORDER #	QTY/UNIT
Sensor Mounting Kit for Imperial & Metric Units (mounts 2 sensors)	OSMK-008	1
NPN Magneto Resistive Sensor with Quick Disconnect*	OHSN-017	1 or 2
PNP Magneto Resistive Sensor with Quick Disconnect*	OHSP-017	1 or 2
Quick Disconnect 2 Meter Cable Length*	CABL-010	1 or 2
Quick Disconnect 5 Meter Cable Length*	CABL-013	1 or 2

PNEUMATIC ACCESSORIES

Fail Safe Valve (Imperial)	OFSV-001	1
Fail Safe Valve (Metric)	OFSV-004	1
Standard Seal Repair Kit	SLKT-010	1
Viton® Seal Repair Kit	SLKT-010V	1

*Sensor and cable sold separately †Piston magnet standard

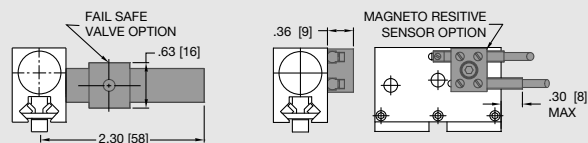



PARALLEL GRIPPER RPL-2M PRECISION DUAL "V" LOW PROFILE SERIES

RPL SERIES

1.93

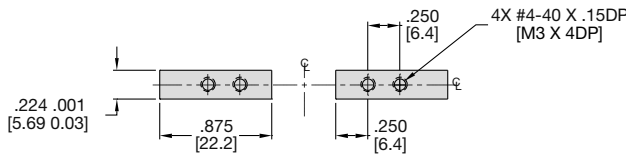
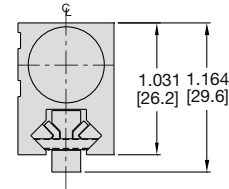
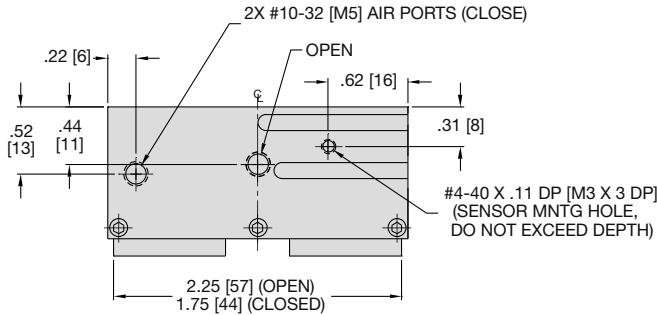
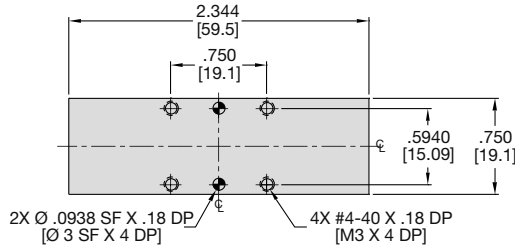

JAW MOUNTING PATTERN
(SHOWN IN OPEN POSITION)

Specifications

	RPL-2	RPL-2M
Total Rated Grip Force F @ 100 psi, 7 bar	26 lbs.	116 N
Stroke	0.50 in.	12.7 mm
Weight	0.20 lbs.	0.09 Kg
Pressure Range	5-100 psi	0.3-7 bar
Cylinder Bore Ø	0.438 in.	11.1 mm
Displacement	0.075 in ³	1.2 cm ³
Temperature Range		
Standard Seals	-30°~180° F	-35°~80° C
Viton® Seals	-20°~250° F	-30°~120° C
Actuation	0.13 sec.	0.13 sec.
Accuracy	±0.002 in.	±0.05 mm
Repeatability	±0.001 in.	±0.03 mm
Valve required to actuate	4-way, 2-position	

UNLESS OTHERWISE NOTED ALL TOLERANCES ARE AS SHOWN BELOW

Imperial in.	Metric [mm]
0.00 = ±.01	[0.] = [±.25]
0.000 = ±.005	[0.0] = [±.13]
0.0000 = ±.0005	[0.00] = [±.013]

Loading Information

How to Order: (Order Accessories separately from Basic Model)

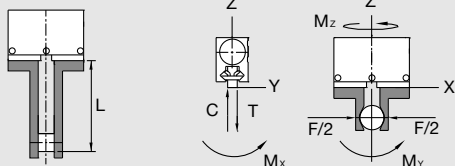
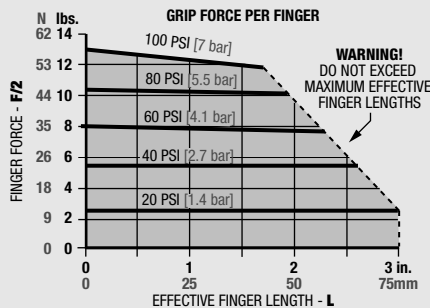

Loading Capacity†

	Static		Dynamic	
	Imperial	Metric	Imperial	Metric
Maximum Tensile T	65 lbs.	289 N	20 lbs.	89 N
Maximum Compressive C	65 lbs.	289 N	20 lbs.	89 N
Maximum Moment M_x	45 in.-lbs.	5.1 Nm	15 in.-lbs.	1.7 Nm
Maximum Moment M_y	60 in.-lbs.	6.8 Nm	20 in.-lbs.	2.3 Nm
Maximum Moment M_z	45 in.-lbs.	5.1 Nm	15 in.-lbs.	1.7 Nm

†Capacities are per set of jaws and are not simultaneous

BASIC MODEL NON-SYNCHRONOUS

RPL-2 M-NS-V

METRIC VITON® SEALS

SENSOR ACCESSORIES*

	ORDER #	QTY/UNIT
Sensor Mounting Kit for Imperial & Metric Units (mounts 2 sensors)	OSMK-008	1
NPN Magneto Resistive Sensor with Quick Disconnect*	OHSN-017	1 or 2
PNP Magneto Resistive Sensor with Quick Disconnect*	OHSP-017	1 or 2
Quick Disconnect 2 Meter Cable Length*	CABL-010	1 or 2
Quick Disconnect 5 Meter Cable Length*	CABL-013	1 or 2

PNEUMATIC ACCESSORIES

Fail Safe Valve (Imperial)	OFSV-001	1
Fail Safe Valve (Metric)	OFSV-004	1
Standard Seal Repair Kit	SLKT-010	1
Viton® Seal Repair Kit	SLKT-010V	1

*Sensor and cable sold separately †Piston magnet standard

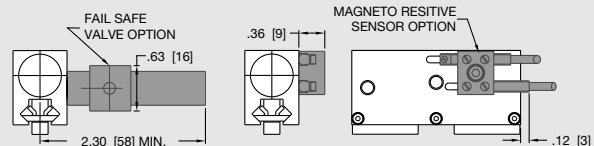

PARALLEL GRIPPER RPL-3M PRECISION DUAL "V" LOW PROFILE SERIES

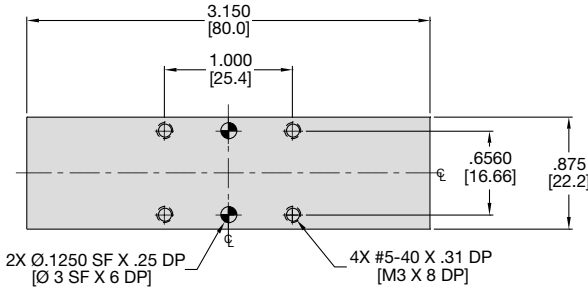

Specifications

	RPL-3	RPL-3M
Total Rated Grip Force F @ 100 psi, 7 bar	36 lbs.	160 N
Stroke	0.75 in.	19.1 mm
Weight	0.32 lbs.	0.15 Kg
Pressure Range	5-100 psi	0.3-7 bar
Cylinder Bore Ø	0.500 in.	12.7 mm
Displacement	0.147 in ³	2.4 cm ³
Temperature Range		
Standard Seals	-30°~180° F	-35°~80° C
Viton® Seals	-20°~250° F	-30°~120° C
Actuation	0.14 sec.	0.14 sec.
Accuracy	±0.002 in.	±0.05 mm
Repeatability	±0.001 in.	±0.03 mm
Valve required to actuate	4-way, 2-position	

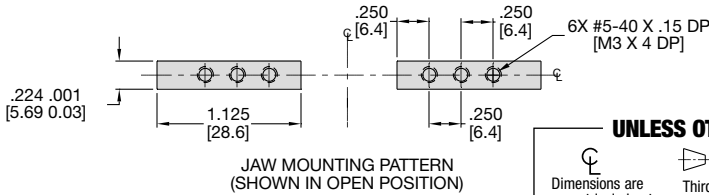
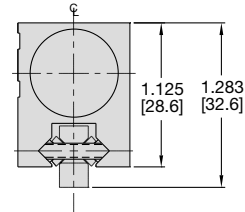
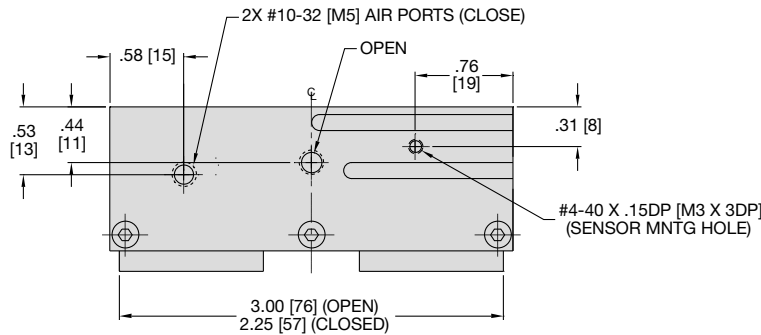

UNLESS OTHERWISE NOTED ALL TOLERANCES ARE AS SHOWN BELOW

Symbol	Imperial in.	Metric [mm]
	0.00 ± .01	[0.] = [±.25]
	0.000 ± .005	[0.0] = [±.13]
	0.0000 ± .0005	[0.00] = [±.013]

Dimensions are symmetrical about centerline
 Third Angle Projection
 All Dowel Holes are SF (Slip Fit). Locational Tolerance ±.0005" or [±.013mm]
 Metric Threads Course Pitch

Loading Information

How to Order: (Order Accessories separately from Basic Model)

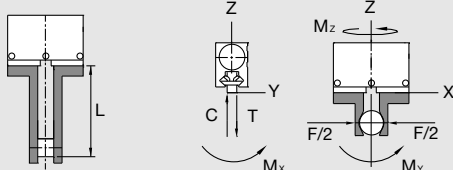
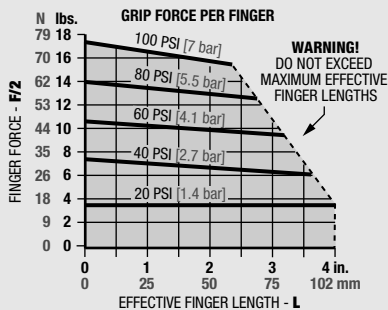

Loading Capacity†	Static		Dynamic	
	Imperial	Metric	Imperial	Metric
Maximum Tensile T	90 lbs.	400 N	30 lbs.	133 N
Maximum Compressive C	90 lbs.	400 N	30 lbs.	133 N
Maximum Moment M_x	60 in.-lbs.	6.8 Nm	20 in.-lbs.	2.3 Nm
Maximum Moment M_y	80 in.-lbs.	9.0 Nm	25 in.-lbs.	2.8 Nm
Maximum Moment M_z	60 in.-lbs.	6.8 Nm	20 in.-lbs.	2.3 Nm

†Capacities are per set of jaws and are not simultaneous

BASIC MODEL NON-SYNCHRONOUS

RPL-3 M-NS-V

METRIC VITON® SEALS

SENSOR ACCESSORIES*

	ORDER #	QTY/UNIT
Sensor Mounting Kit for Imperial & Metric Units (mounts 2 sensors)	OSMK-008	1
NPN Magneto Resistive Sensor with Quick Disconnect*	OHSN-017	1 or 2
PNP Magneto Resistive Sensor with Quick Disconnect*	OHSP-017	1 or 2
Quick Disconnect 2 Meter Cable Length*	CABL-010	1 or 2
Quick Disconnect 5 Meter Cable Length*	CABL-013	1 or 2

PNEUMATIC ACCESSORIES

Fail Safe Valve (Imperial)	OFSV-001	1
Fail Safe Valve (Metric)	OFSV-004	1
Standard Seal Repair Kit	SLKT-012	1
Viton® Seal Repair Kit	SLKT-012V	1

*Sensor and cable sold separately †Piston magnet standard

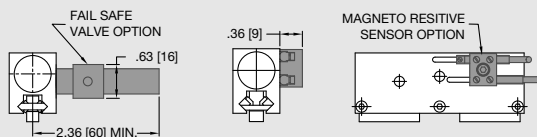



PARALLEL GRIPPER RPL-4M PRECISION DUAL "V" LOW PROFILE SERIES

RPL SERIES

1.95

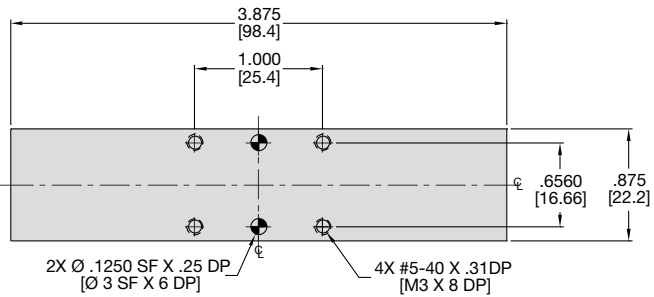

Specifications	RPL-4	RPL-4M
Total Rated Grip Force F @ 100 psi, 7 bar	36 lbs.	160 N
Stroke	1.00 in.	25.4 mm
Weight	0.38 lbs.	0.17 Kg
Pressure Range	5-100 psi	0.3-7 bar
Cylinder Bore Ø	0.500 in.	12.7 mm
Displacement	0.196 in ³	3.2 cm ³
Temperature Range		
Standard Seals	-30°~180° F	-35°~80° C
Viton® Seals	-20°~250° F	-30°~120° C
Actuation	0.19 sec.	0.19 sec.
Accuracy	±0.002 in.	±0.05 mm
Repeatability	±0.001 in.	±0.03 mm
Valve required to actuate	4-way, 2-position	

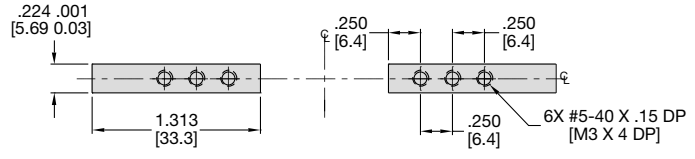
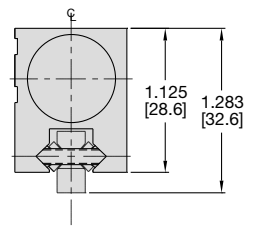
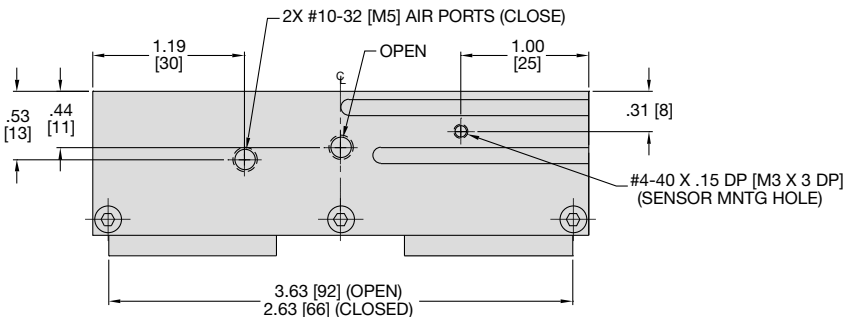

JAW MOUNTING PATTERN (SHOWN IN OPEN POSITION)

UNLESS OTHERWISE NOTED ALL TOLERANCES ARE AS SHOWN BELOW

Dimensions are symmetrical about centerline	Third Angle Projection	All Dowel Holes are SF (Slip Fit). Locational Tolerance ±.0005" or [±.013mm]	Metric Threads Course Pitch	Imperial in. 0.00 = ±.01 0.000 = ±.005 0.0000 = ±.0005	Metric [mm] [0.] = [±.25] [0.0] = [±.13] [0.00] = [±.013]
---	------------------------	--	-----------------------------	--	---

Loading Information

How to Order: (Order Accessories separately from Basic Model)

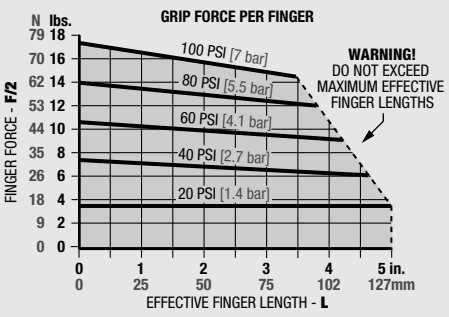

BASIC MODEL NON-SYNCHRONOUS

RPL-4 M - NS - V

METRIC VITON® SEALS

SENSOR ACCESSORIES*	ORDER #	QTY/UNIT
Sensor Mounting Kit for Imperial & Metric Units (mounts 2 sensors)	OSMK-008	1
NPN Magneto Resistive Sensor with Quick Disconnect*	OHSN-017	1 or 2
PNP Magneto Resistive Sensor with Quick Disconnect*	OHSP-017	1 or 2
Quick Disconnect 2 Meter Cable Length*	CABL-010	1 or 2
Quick Disconnect 5 Meter Cable Length*	CABL-013	1 or 2
PNEUMATIC ACCESSORIES		
Fail Safe Valve (Imperial)	OFSV-001	1
Fail Safe Valve (Metric)	OFSV-004	1
Standard Seal Repair Kit	SLKT-012	1
Viton® Seal Repair Kit	SLKT-012V	1

*Sensor and cable sold separately *Piston magnet standard

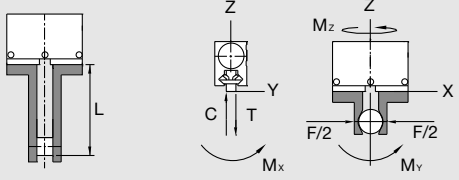

Loading Capacity*	Static		Dynamic	
	Imperial	Metric	Imperial	Metric
Maximum Tensile T	120 lbs.	534 N	40 lbs.	178 N
Maximum Compressive C	120 lbs.	534 N	40 lbs.	178 N
Maximum Moment M_x	75 in.-lbs.	8.5 Nm	25 in.-lbs.	2.8 Nm
Maximum Moment M_y	100 in.-lbs.	11.3 Nm	35 in.-lbs.	4.0 Nm
Maximum Moment M_z	75 in.-lbs.	8.5 Nm	25 in.-lbs.	2.8 Nm

*Capacities are per set of jaws and are not simultaneous

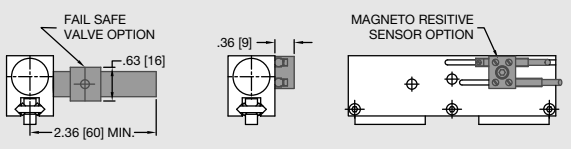

Please see back cover for DE-STA-CO Global Locations. www.destaco.com

www.comoso.com



RPL Series Exploded View

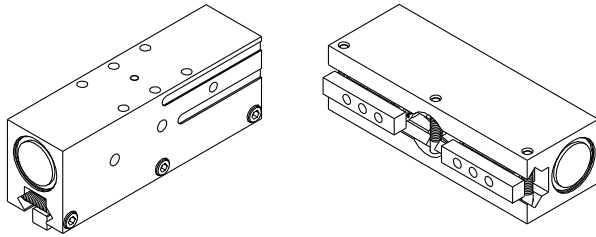

Item	Qty	Name
01	1	Body
02	1	Piston
03	2	Cap
04	1	Equalizer
05	2	Link
06	4	Way
08	2	Jaw
13	2	Pin
20	1	Piston W/Magnet Slot
21	4	S'assy,Cage & Rollers
30	3	SHCS
31	1	Dowel Pin
32	2	Dowel Pin
40	2	Magnet

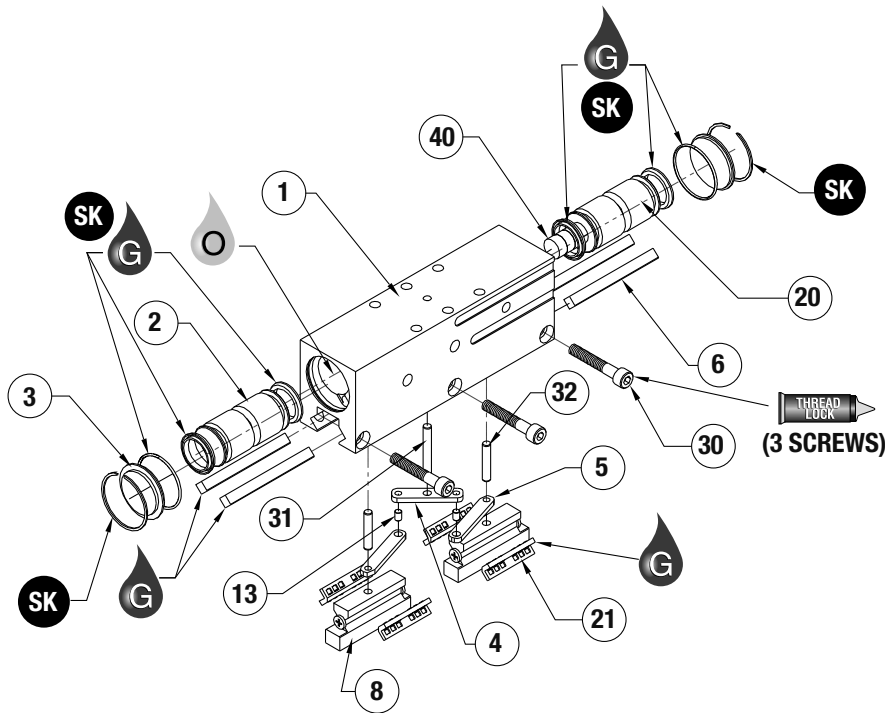

NOTE: Contact the Robohand Sales Department for a complete spare parts list with order numbers and prices.

Assembly Procedure

- 1) Lubricate and install seals.
- 2) Press dowel pin into center of body.
- 3) Place links and equalizers into body.
- 4) Press dowel pins into jaws.
- 5) Place jaws through links and into pistons.
- 6) Install cages on jaws.
- 7) Place ways behind cages with flat facing out and install screws.
- 8) Adjust preload.

Preload Adjustment Procedure

- 1) Tighten center screw (#30) so that fingers bind slightly.
- 2) Tighten outer screws in the same fashion.
- 3) Cycle the gripper.
- 4) Re-adjust screws so that when you push the cage, the finger moves freely. (the finger movement should not feel gritty.)

Non-Synchronous Procedure

- 1) Remove preload screws (#30) and ways.
- 2) Remove cages, jaws and dowel pins.
- 3) Remove equalizer, links, and roller bearings.
- 4) Re-assemble jaws and dowel pins into pistons.
- 5) Re-install cages on jaws.
- 6) Place ways behind cages with flat facing out and install preload screws.
- 7) Adjust preload.

SK Seal Repair Kit Order #'s See Product Data Sheets

SK Seal Kit Items	THREAD LOCKER Thread Locker	KRYTOX Lubricant	Lightweight Machine Oil	Teflon™ Based Grease	Super Bonder	Third Angle Projection

Please see back cover for DE-STA-CO Global Locations. www.destaco.com

www.comoso.com

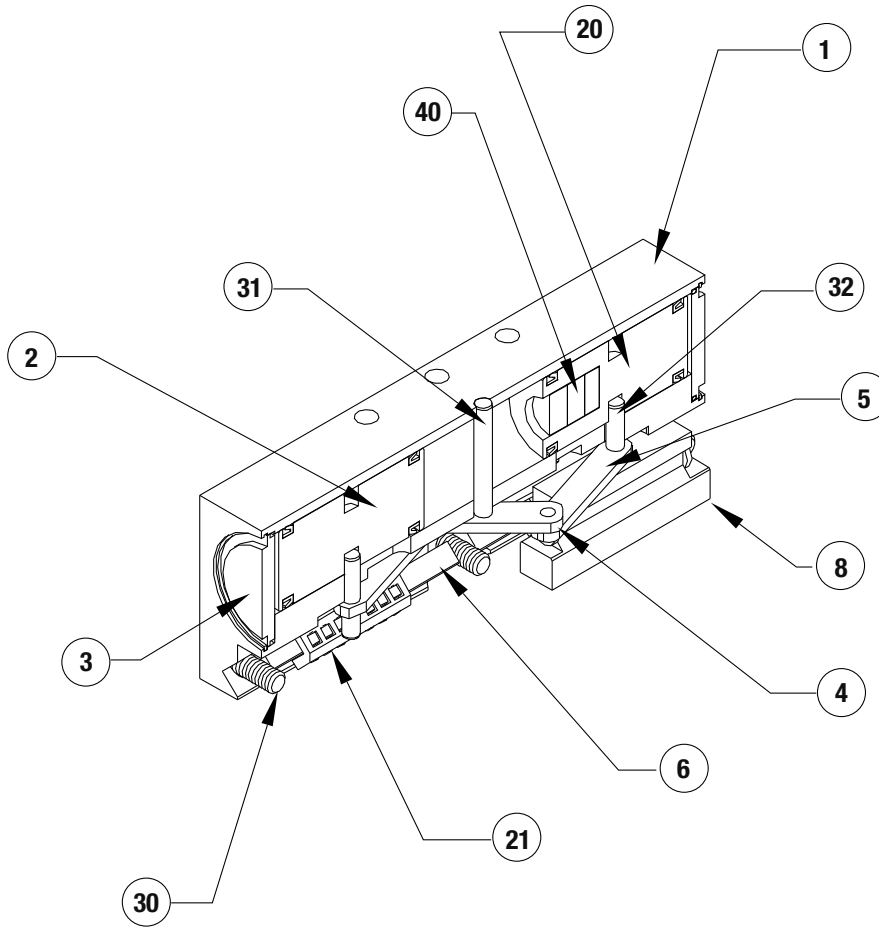

Item	Qty	Name
01	1	Body
02	1	Piston
03	2	Cap
04	1	Equalizer
05	2	Link
06	4	Way
08	2	Jaw
13	2	Bearing,Roller
20	1	Piston W/Magnet Slot
21	4	S'assy,Cage & Rollers
30	3	SHCS
31	1	Dowel Pin
32	2	Dowel Pin
40	2	Magnet

NOTE: Contact the Robohand Sales Department for a complete spare parts list with order numbers and prices.

Accessory Installation & Adjustment Instructions

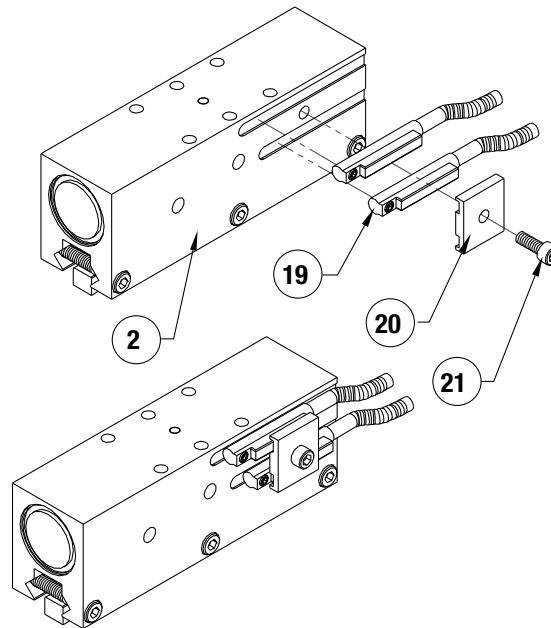

Installation

1. Install sensors as shown.
2. Adjust for desired end of stroke detection.



Seal Kit
Items



Thread
Locker



Krytox™
Lubricant



Lightweight
Machine Oil



Teflon™ Based
Grease



Super
Bonder



Third Angle
Projection