

Feed Escapements

- Part separation:**
 A feed escapement is the most effective mechanism for separating components fed from a track or conveyor.
- Failsafe locking fingers:**
 This feature eliminates the premature retraction of the extended finger by utilizing a locking key design. This will minimize part jamming and multiple parts feeding at a time.

RFE SERIES

5.2

Mounting Information:

Escapements can be mounted & operated in any orientation

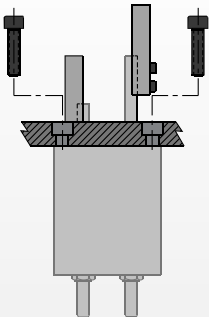

Body face mounts with screws

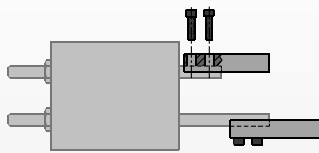

Fingers attach to shafts with screws and locate by keying

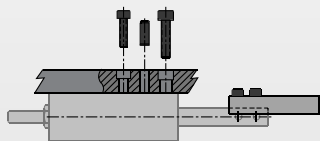

Body mounts with screws from above or below and locates with slip fit dowel holes

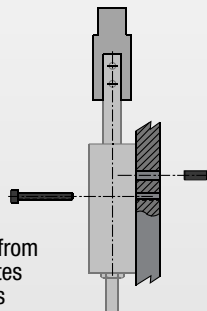

Technical Specifications:

Pneumatic Specifications

Pressure Operating Range
 Cylinder Type
 Dynamic Seals
 Valve Required to Operate

Imperial	Metric
40-100 psi	3-7 bar
Dual Double Acting	
Internally Lubricated Buna-N	
4-way, 2-position	

Air Quality Requirements

Air Filtration
 Air Lubrication
 Air Humidity

40 Micron or Better
Not Necessary*
Low Moisture Content (dry)

Temperature Operating Range

Buna-N Seals (standard)
 Viton® Seals (optional)

-30°~180° F	-35°~80° C
-20°~300° F	-30°~150° C

Maintenance Specifications†

Expected Life
 Normal Application
 w/ Preventative Maintenance
 Field Repairable
 Seal Repair Kits Available

5 million cycles
10+ million cycles*
Yes
Yes

*Addition of lubrication will greatly increase service life
 †See Maintenance Section

Product Features

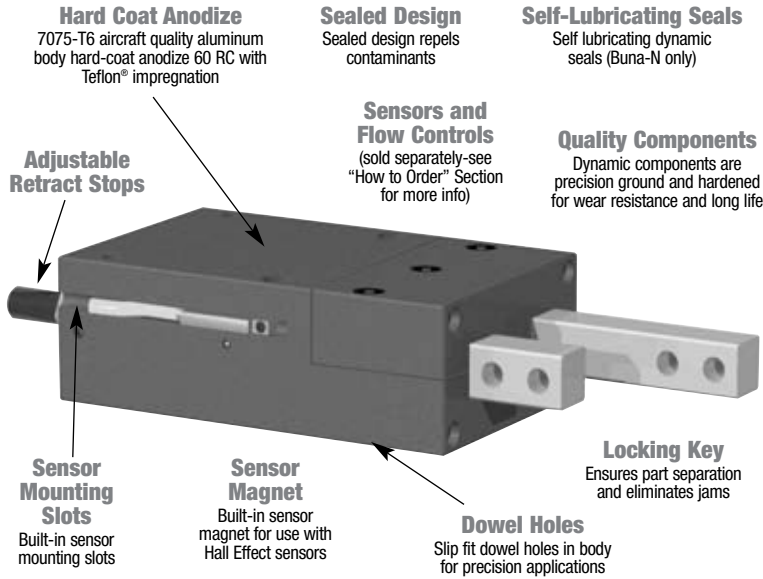

Operating Principle

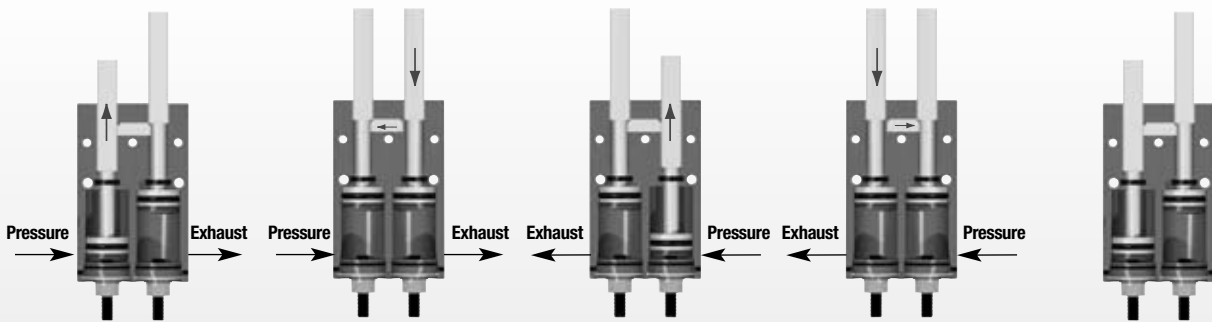
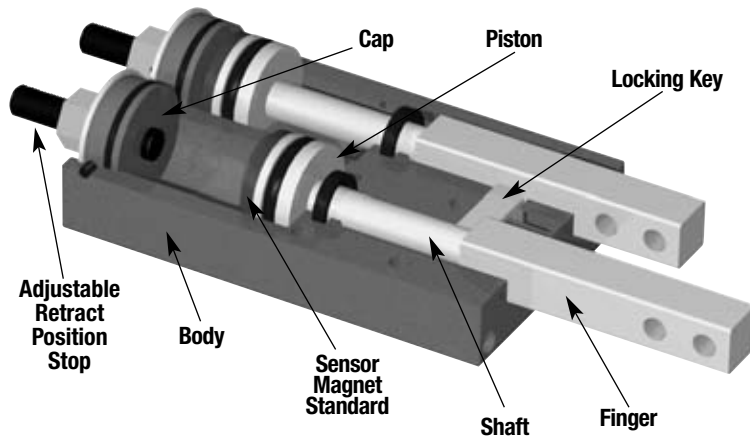

- Dual double acting pistons slide in opposite directions within the body through the use of internal porting.
- When pressure is applied, one piston extends and passes a port in it's cylinder wall which is linked to the retract side of the other piston's cylinder.
- The second piston then begins to retract and pushes the locking key aside into the cavity on the side of the first finger.
- Locking Key ensures only 1 finger can be retracted at a time.
- Finger must be allowed to fully extend for proper operation.

Designed and manufactured in the USA

Style-RFE Feed Escapement

Size -11M

Style:	RFE-11M	
Stroke:	0.625"	15.9mm
Thrust Force:	25 lb	111 N
Weight:	.33 lb	.15 Kg



See Page **5.4**

Style-RFE Feed Escapement

Size-12M

Style:	RFE-12M	
Stroke:	1.00"	25.4mm
Thrust Force:	50 lb	222 N
Weight:	.85 lb	.39 Kg



See Page **5.5**

Style-RFE Feed Escapement

Size-13M

Style:	RFE-13M	
Stroke:	1.25"	31.8mm
Thrust Force:	90 lb	400 N
Weight:	1.84 lb	.83 Kg



See Page **5.6**

FEED ESCAPEMENTS RFE-11M NON-ROTATING FINGER SERIES

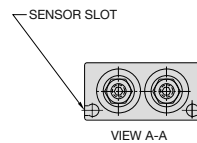
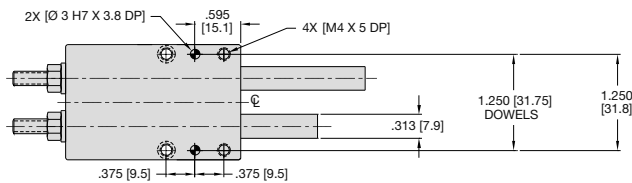
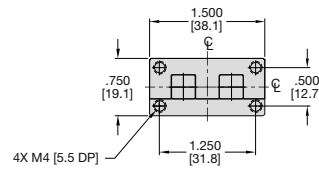
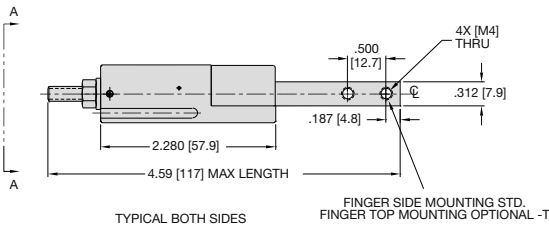
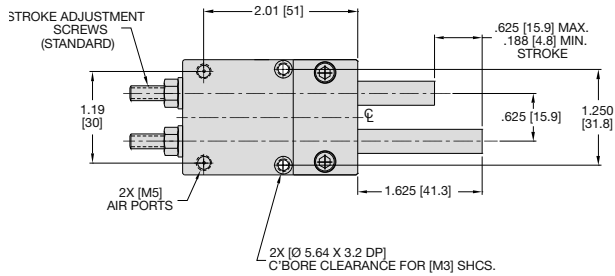

UNLESS OTHERWISE NOTED ALL TOLERANCES ARE AS SHOWN BELOW

Dimensions are symmetrical about centerline	Third Angle Projection	All Dowel Holes are SF (Slip Fit). Locational Tolerance ±.0005" or [±.013mm]	Metric Threads Course Pitch	Imperial in. 0.00 ± .01 0.000 ± .005 0.0000 ± .0005	Metric [mm] [0.] = [±.25] [0.0] = [±.13] [0.00] = [±.013]
---	------------------------	--	-----------------------------	---	---

RFE SERIES

5.4

Loading Information

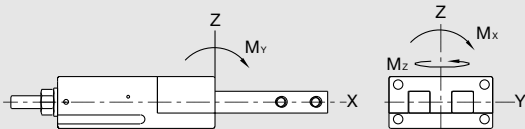

Loading Capacity	Static	Dynamic
Maximum Moment M_x	50 in.-lbs. [6 Nm]	5.0 in.-lbs. [0.57 Nm]
Maximum Moment M_y	50 in.-lbs. [6 Nm]	5.0 in.-lbs. [0.57 Nm]
Maximum Moment M_z	50 in.-lbs. [6 Nm]	5.0 in.-lbs. [0.57 Nm]

Thrust Force of Cylinders

Thrust Force	Extend	Retract
Thrust Force @ 100 PSI	25 lbs. [111 N]	20 lbs. [88 N]
Thrust Force @ 80 PSI	25 lbs. [88 N]	16 lbs. [70 N]
Thrust Force @ 60 PSI	15 lbs. [66 N]	12 lbs. [53 N]
Thrust Force @ 40 PSI	10 lbs. [44 N]	8 lbs. [35 N]
Thrust Force @ 20 PSI	5 lbs. [22 N]	4 lbs. [17 N]

How to Order: (Order Accessories separately from Basic Model)

BASIC MODEL

VITON® SEALS

RFE-11M - T - V

TOP FINGER MOUNTING

SENSOR ACCESSORIES	Order #	QTY/UNIT
NPN Hall Effect Sensor with Quick Disconnect*	OHSN-017	1 or 2
PNP Hall Effect Sensor with Quick Disconnect*	OHSP-017	1 or 2
Quick Disconnect 2M Cable Length*	CABL-010	1 or 2
Quick Disconnect 5M Cable Length*	CABL-013	1 or 2
PNEUMATIC ACCESSORIES		
M5 Adjustable Flow Control	VLVF-008	1 or 2
Standard Seal Repair Kit	SLKT-110	1
Viton® Seal Repair Kit	SLKT-110V	1

*Sensor and cable sold separately.

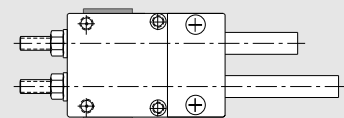
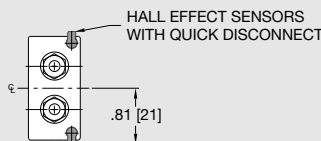



FEED ESCAPEMENTS RFE-12M NON-ROTATING FINGER SERIES

Specifications	RFE-12M	
Thrust Force @ Maximum PSI	50 lbs.	222 N
Stroke	1.000 in.	25.40 mm
Stroke Adjustability	0.75 in.	19 mm
Weight	0.85 lbs.	0.39 Kg
Pressure Range	40-100 psi	3-7 bar
Cylinder Bore Ø	0.787 in.	20 mm
Rod Ø	0.313 in.	7.95 mm
Displacement	0.487 in ³	8.0 cm ³
Temperature Range		
Standard Seals	-30°~180° F	-35°~80° C
Viton® Seals	-20°~300° F	-30°~150° C
Actuation Time	0.60 sec.	0.60 sec.
Parts Escaped per Minute	100	100
Valve required to actuate	4-way, 2-position	

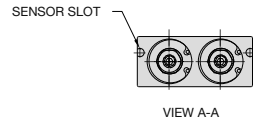
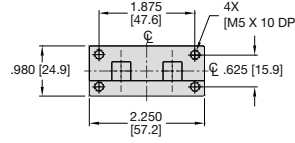
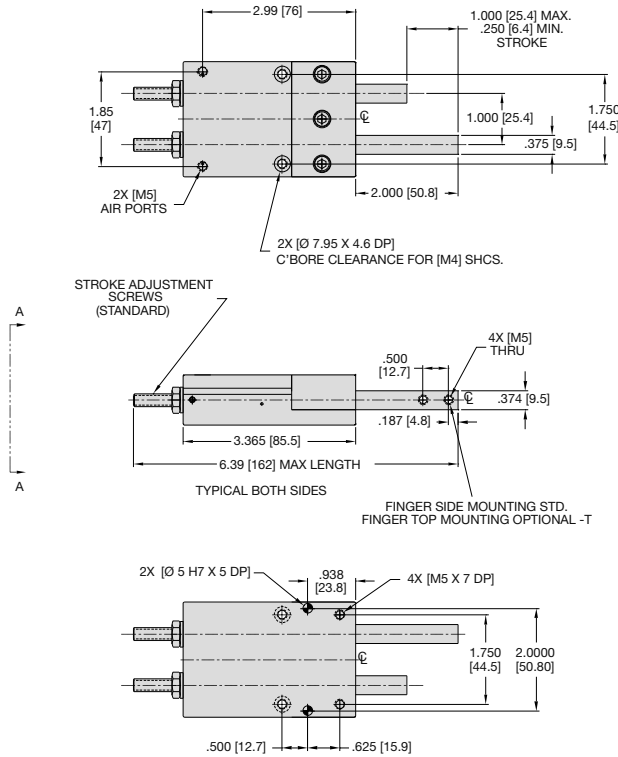

UNLESS OTHERWISE NOTED ALL TOLERANCES ARE AS SHOWN BELOW

Imperial in.	Metric [mm]
0.00 = ±.01	[0.] = ±.25
0.000 = ±.005	[0.0] = ±.13
0.0000 = ±.0005	[0.00] = ±.013

Dimensions are symmetrical about centerline
 Third Angle Projection
 All Dowel Holes are SF (Slip Fit). Locational Tolerance ±.0005" or [±.013mm]
 Metric Threads Course Pitch

Loading Information

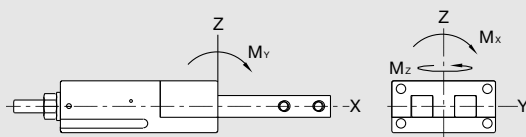

Loading Capacity	Static	Dynamic
Maximum Moment M_x	150 in.-lbs. [17 Nm]	15.0 in.-lbs. [1.70 Nm]
Maximum Moment M_y	150 in.-lbs. [17 Nm]	15.0 in.-lbs. [1.70 Nm]
Maximum Moment M_z	150 in.-lbs. [17 Nm]	15.0 in.-lbs. [1.70 Nm]

Thrust Force of Cylinders

Thrust Force	Extend	Retract
Thrust Force @ 100 PSI	50 lbs. [216 N]	40 lbs. [182 N]
Thrust Force @ 80 PSI	40 lbs. [173 N]	32 lbs. [146 N]
Thrust Force @ 60 PSI	30 lbs. [130 N]	25 lbs. [109 N]
Thrust Force @ 40 PSI	20 lbs. [86 N]	16 lbs. [73 N]
Thrust Force @ 20 PSI	10 lbs. [43 N]	8 lbs. [36 N]

How to Order: (Order Accessories separately from Basic Model)

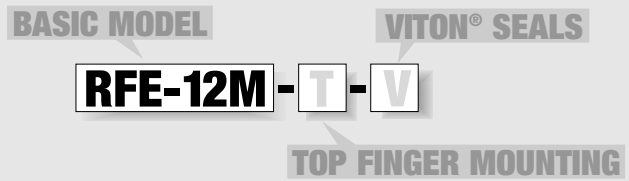

SENSOR ACCESSORIES	Order #	QTY/UNIT
NPN Hall Effect Sensor with Quick Disconnect*	OHSN-017	1 or 2
PNP Hall Effect Sensor with Quick Disconnect*	OHSP-017	1 or 2
Quick Disconnect 2M Cable Length*	CABL-010	1 or 2
Quick Disconnect 5M Cable Length*	CABL-013	1 or 2

PNEUMATIC ACCESSORIES	Order #	QTY/UNIT
M5 Adjustable Flow Control	VLVF-008	1 or 2
Standard Seal Repair Kit	SLKT-111	1
Viton® Seal Repair Kit	SLKT-111V	1

*Sensor and cable sold separately.

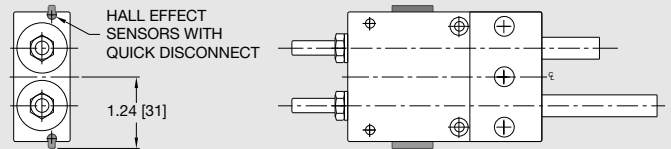

FEED ESCAPEMENTS RFE-13M NON-ROTATING FINGER SERIES

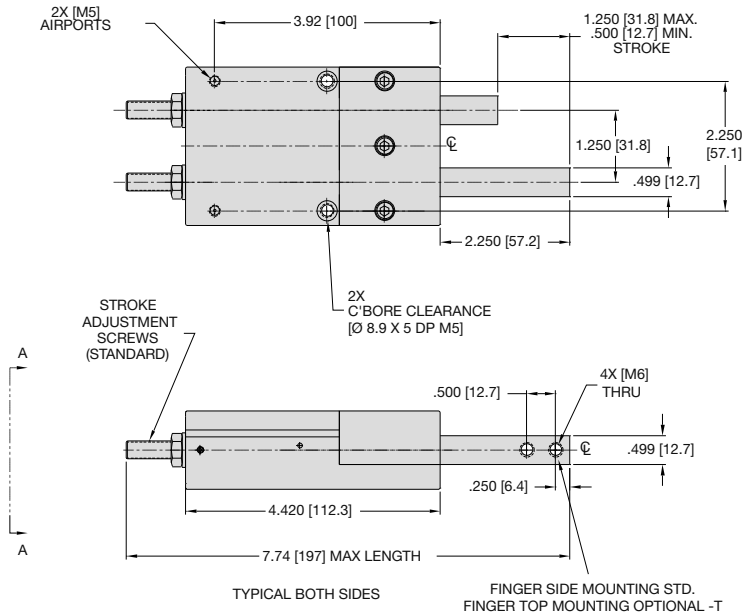

Specifications

	RFE-13M	
Thrust Force @ Maximum PSI	90 lbs.	400 N
Stroke	1.250 in.	31.75 mm
Stroke Adjustability	0.75 in.	19 mm
Weight	1.84 lbs.	0.83 Kg
Pressure Range	40-100 psi	3-7 bar
Cylinder Bore Ø	1.063 in.	27 mm
Rod Ø	0.375 in.	9.52 mm
Displacement	1.108 in ³	18.2 cm ³
Temperature Range		
Standard Seals	-30°~180° F	-35°~80° C
Viton® Seals	-20°~300° F	-30°~150° C
Actuation Time	0.70 sec.	0.70 sec.
Parts Escaped per Minute	85	85
Valve Required to Actuate	4-way, 2-position	

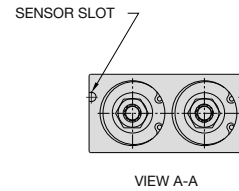
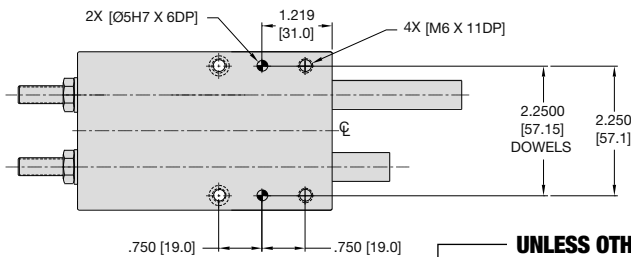
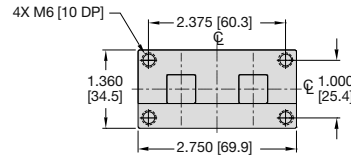

UNLESS OTHERWISE NOTED ALL TOLERANCES ARE AS SHOWN BELOW

	Imperial in.	Metric [mm]
Dimensions are symmetrical about centerline	0.00 = ±.01	[0.] = ±.25
Third Angle Projection	0.000 = ±.005	[0.0] = ±.13
All Dowel Holes are SF (Slip Fit). Locational Tolerance ±.0005" or [±.013mm]	0.0000 = ±.0005	[0.00] = ±.013
Metric Threads		
Course Pitch		

RFE SERIES

5.6

Loading Information

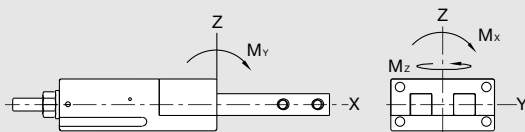

Loading Capacity	Static	Dynamic
Maximum Moment M_x	250 in.-lbs. [28 Nm]	25.0 in.-lbs. [2.83 Nm]
Maximum Moment M_y	250 in.-lbs. [28 Nm]	25.0 in.-lbs. [2.83 Nm]
Maximum Moment M_z	250 in.-lbs. [28 Nm]	25.0 in.-lbs. [2.83 Nm]

How to Order: (Order Accessories separately from Basic Model)

BASIC MODEL

VITON® SEALS

RFE-13M - T - V

TOP FINGER MOUNTING

SENSOR ACCESSORIES

	Order #	QTY/UNIT
NPN Hall Effect Sensor with Quick Disconnect*	OHSN-017	1 or 2
PNP Hall Effect Sensor with Quick Disconnect*	OHSP-017	1 or 2
Quick Disconnect 2M Cable Length*	CABL-010	1 or 2
Quick Disconnect 5M Cable Length*	CABL-013	1 or 2

PNEUMATIC ACCESSORIES

	Order #	QTY/UNIT
M5 Adjustable Flow Control	VLVF-008	1 or 2
Standard Seal Repair Kit	SLKT-112	1
Viton® Seal Repair Kit	SLKT-112V	1

*Sensor and cable sold separately.

Thrust Force of Cylinders

Thrust Force	Extend	Retract
Thrust Force @ 100 PSI	88 lbs. [394 N]	77 lbs. [345 N]
Thrust Force @ 80 PSI	71 lbs. [315 N]	62 lbs. [276 N]
Thrust Force @ 60 PSI	53 lbs. [236 N]	46 lbs. [207 N]
Thrust Force @ 40 PSI	35 lbs. [157 N]	31 lbs. [138 N]
Thrust Force @ 20 PSI	17 lbs. [78 N]	15 lbs. [69 N]

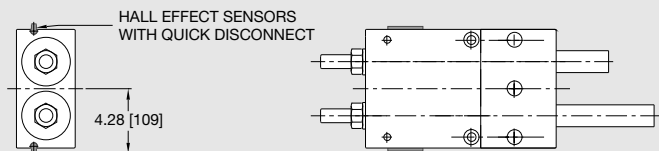

Please see back cover for DE-STA-CO Global Locations. www.destaco.com

www.comoso.com

Item Qty	Name
01	1 Body
02	2 Finger
03	2 Piston
04	2 Cap
05	1 Cover, Finger
07	1 Shuttle Slug
30	2 Stop_Screw
32	2 Jam Nut
33	2 Dowel Pin
34	2 SSS,Cup Point
40	2 Magnet, Ring

NOTE: Contact the Robohand Sales Department for a complete spare parts list with order numbers and prices.

Assembly Procedure

- 1) Super bond magnet to piston.
- 2) Lubricate u-cup and install into body.
- 3) Orient fingers and slide into body.
- 4) Attach pistons to fingers in bores, using spanner.
- 5) Install caps, o-rings and adjustment screws into body with retainer ring.
- 6) Lock in caps by tightening set screws.
- 7) Press dowel pins in finger cover.
- 8) Place shuttle slug in position.
- 9) Install finger cover.

Stroke Adjustment Procedure

- 1) The stroke of each finger can be adjusted by its respective set screw (#30).
- 2) To reduce the stroke of the desired finger on retraction, tighten its respective set screw.note: stroke can only be reduced on retraction; (the finger will always extend the same distance away from the body). Stroke cannot be increased more than the value stated in the catalog.

SK Seal Repair Kit Order #'s
See Product Data Sheets

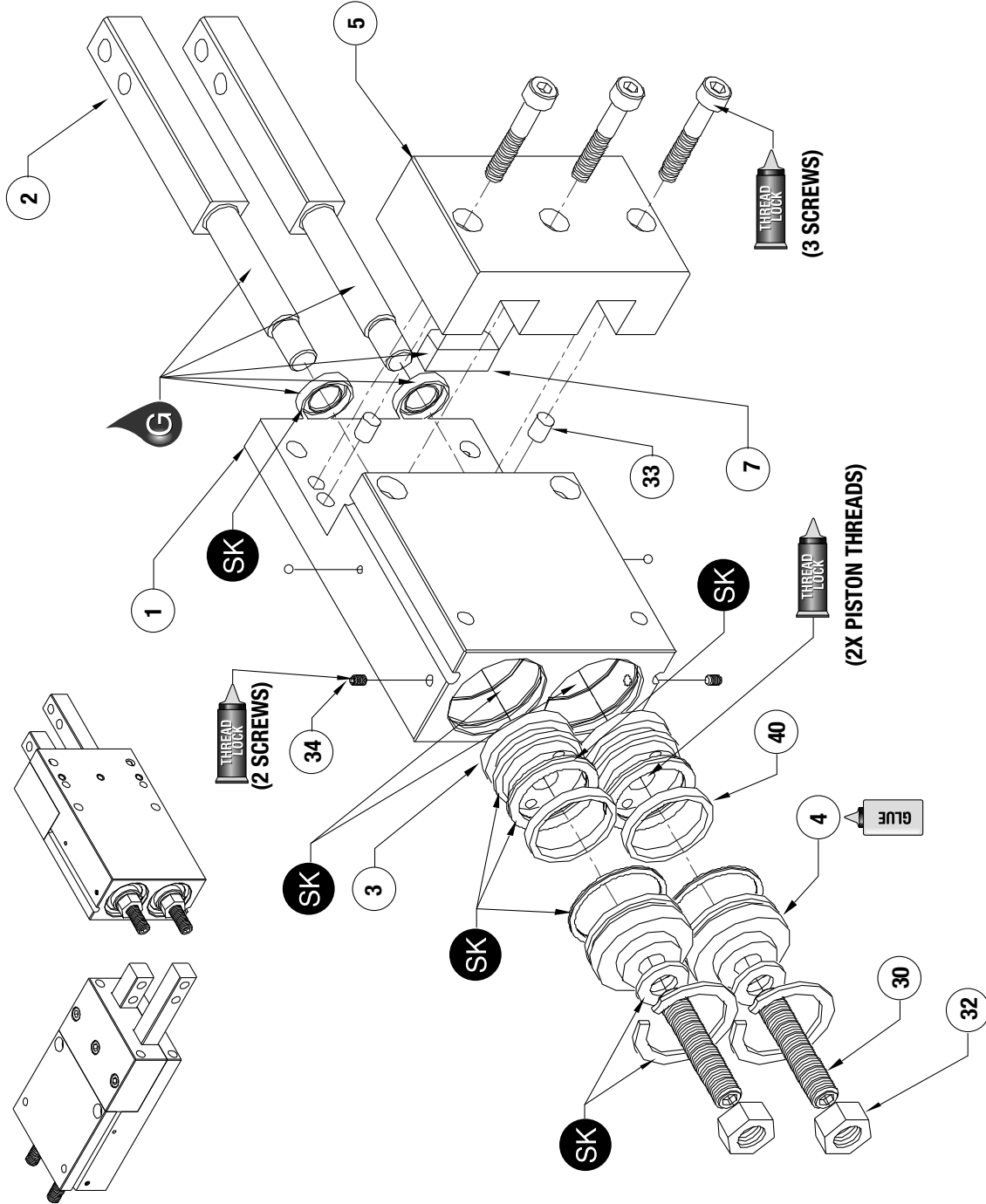

SK	Seal Kit Items
	Thread Locker
	Krytox™ Lubricant
	Lightweight Machine Oil
	Teflon® Based Grease
	Super Bond Glue
	Third Angle Projection

RFE Series Assembled View

Item	Qty	Name
01	1	Body
02	2	Finger
03	2	Piston
04	2	Cap
05	1	Cover, Finger
07	1	Shuttle Slug
30	2	Stop, Screw
32	2	Jam Nut
33	2	Dowel Pin
34	2	SSS, Cup Point
40	2	Magnet, Ring

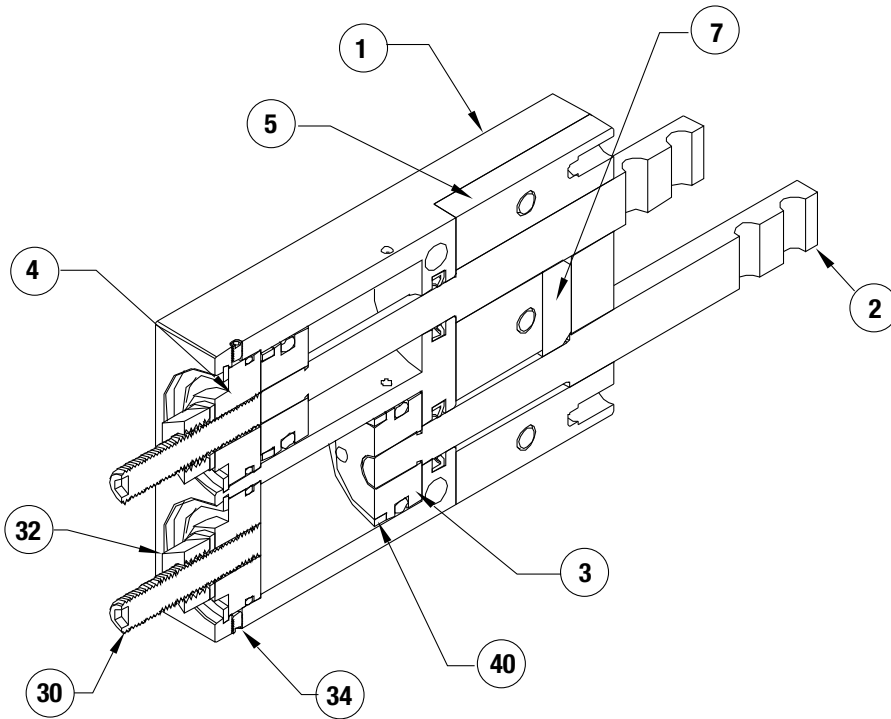

NOTE: Contact the Robohand Sales Department for a complete spare parts list with order numbers and prices.

RFE SERIES

5.8

Accessory Installation & Adjustment Instructions

Sensor Installation

1. Install sensors (2) in profile slots of escapement body (1) as shown.
2. Set sensors with integrated setscrew.

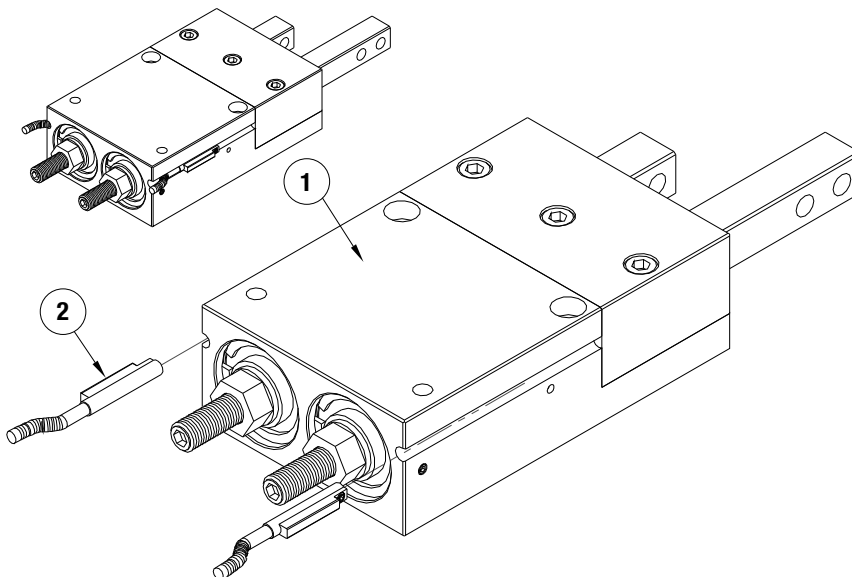

Seal Kit Items



Thread Locker



Krytox™ Lubricant



Lightweight Machine Oil



Teflon® Based Grease



Super Bonder



Third Angle Projection

Please see back cover for DE-STA-CO Global Locations. www.destaco.com

www.comoso.com