

# Rotary Actuators- Light Duty, Flange Output

**• Tight spaces:**

The “ultra thin” profile and bearing supported flange provide an extremely compact package for tight space applications. Payload can be connected directly to the flange without the need for extra bearing support.

**• Precision applications:**

Zero backlash, preloaded ball bearings, and slip fit dowel pins make this a very precise and repeatable rotary actuator.

**• Rotary Air Manifold**

Eliminates twisted airline.



## Mounting Information:

### Mounts and operates in any orientation

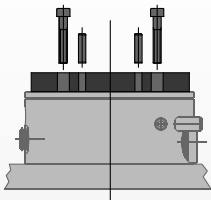

Payload attaches to flange with screws and locates by using dowel pins

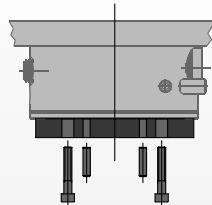

Unit can operate inverted with payload attached to the flange.

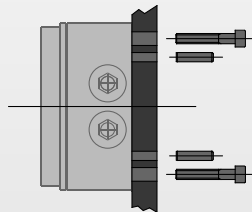

Body mounts with screws and locates with dowel pins for accuracy

## Technical Specifications:

### Pneumatic Specifications

Pressure Operating Range  
Cylinder Type  
Dynamic Seals  
Valve Required to Operate

<b>Imperial</b>	<b>Metric</b>
30-100 psi	2-7 bar
Dual Double Acting	
Internally Lubricated Buna-N	
4-way, 2-position	

### Air Quality Requirements

Air Filtration  
Air Lubrication  
Air Humidity

40 Micron or Better
Not Necessary*
Low Moisture Content (dry)

### Temperature Operating Range

Buna-N Seals (standard)  
Viton Seals (optional)

-30°~180° F	-35°~80° C
-20°~300° F	-30°~150° C

### Maintenance Specifications<sup>†</sup>

Expected Life  
Normal Application  
w/ Preventative Maintenance  
Field Repairable  
Seal Repair Kits Available

5 million cycles
10+ million cycles*
Yes
Yes

\*Addition of lubrication will greatly increase service life  
<sup>†</sup>See Maintenance Section

## Product Features

### Non-Adjustable Flow Controls

Built-in for smooth motion. Additional adjustable flow controls available

### Hardened Tool Steel

Rack and pinion components are made from hardened tool steels

### Optional Flange Seal

For harsh environments. Can be used with purge or scavenge port

### Dowel Holes

Slip fit dowel holes in body and flange

### Flange Hardstops

Located directly on the flange beneath the payload

### Optional Clean Room Seal

Assembled with flange seal, clean room grade lubricant, and corrosion resistant hardware

### Sensors

Sensors and Mounting Kits sold separately

### Preloaded Bearing

Precision bearing is preloaded for maximum support and zero play

### Optional Single Line Rotary Manifold

Eliminates twisted air line

### Adjustable Stop Screws

Adjustable stop screws to adjust rotational position

### Self-Lubricating Seals

Self lubricating dynamic seals (Buna-N only)

### Direct Replacement

RR-18 & RR-28 are retrofittable from RR-16 & RR-26

### Quality Components

One piece high strength 6013-T6 aircraft quality aluminum body and flange

### Anodized Components

Body and flange are hard-coat anodize to 60RC with Teflon® impregnation

## Operating Principle

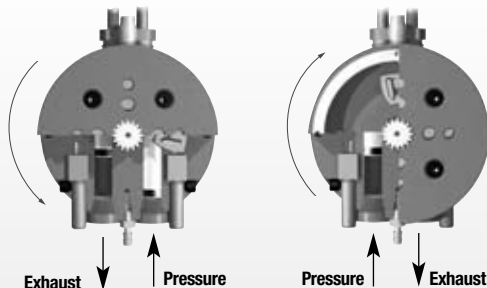
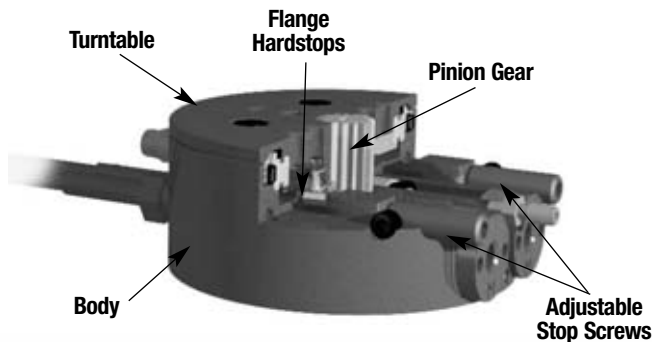

- Air pressure supplied to both cylinders simultaneously using internal porting, drives the piston racks in opposite directions.
- The piston racks simultaneously drive the pinion gear which is attached to the flange.
- The flange is supported in the body by a preloaded ball bearing
- Hardstops, located directly on the flange, reduce wear on internal drive components.

**Designed and manufactured in the USA**

## Style-RR Rotary Actuator

### Size -18M

Style:	RR-18	RR-18M
Max. Payload:	1 lbs.	0.45 Kg
Torque:	6.5 in/lbs	0.7 N-m
Weight:*	0.44 lbs.	0.20 Kg

\*Base unit.

See Page **3.28**



## Style-RR Rotary Actuator

### Size -28M

Style:	RR-28	RR-28M
Max. Payload:	3 lbs.	1.3 Kg
Torque:	22 in/lbs	2.5 N-m
Weight:*	1.20 lbs.	0.55 Kg

\*Base unit.

See Page **3.29**



# ROTARY ACTUATORS RR-18M FLANGE OUTPUT SERIES



RR SERIES

3.28

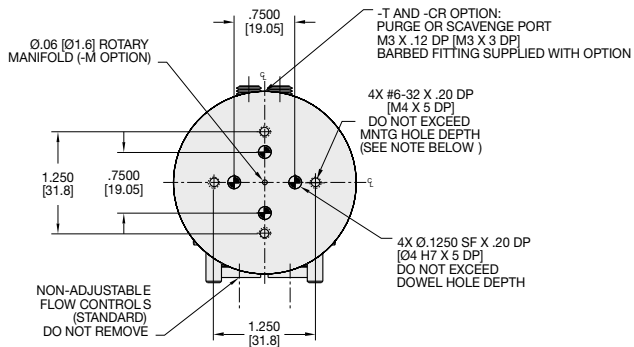

UNIT SHOWN IN 0° POSITION ROTATED FULLY CW

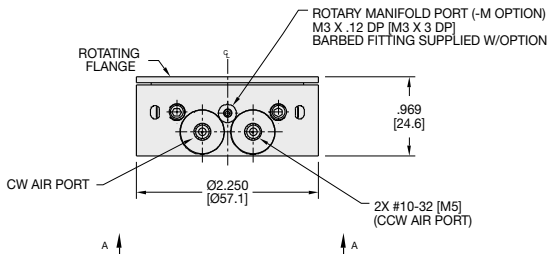

PLEASE NOTE: THE ONLY FEATURES THAT ARE NOT DIRECTLY RETROFITABLE TO THE RR-16 IS THE SHALLOWER TAP DOWEL DEPTH ON THE TURNTABLE AND THE DIFFERENT SENSORS AND SENSOR MOUNTING KIT.

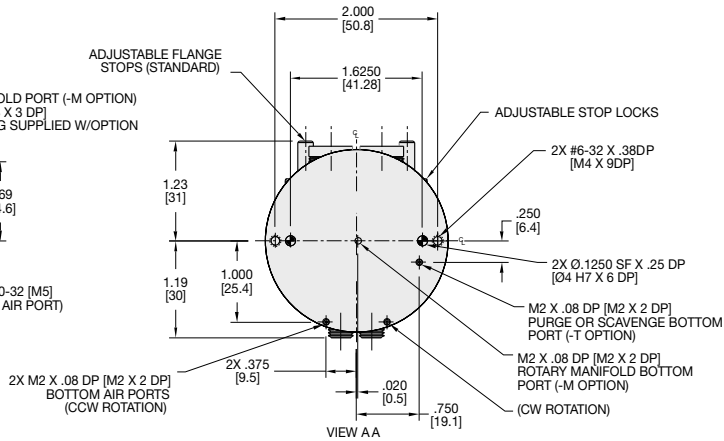

Specifications	RR-18	RR-18M
Maximum Payload.....	1.0 lbs.	0.45 Kg
Maximum Payload Inertia.....	0.0016 in-lb-sec <sup>2</sup>	0.000181 N-m-sec <sup>2</sup>
Maximum Rotation.....	180°	180°
Maximum Torque Mid-Stroke @ 100 PSI .....	6.5 in.-lbs.	0.7 N-m
Maximum Torque End of Stroke @ 100 PSI ..	6.5 in.-lbs.	0.7 N-m
Pitch Diameter of Pinion.....	0.333 in.	8.46mm
Weight .....	0.48 lbs.	0.22 Kg
Pressure Range.....	30-100 psi	2-7 bar
Bore Ø (2X).....	0.500 in.	12.70 mm
Displacement .....	0.205 in <sup>3</sup>	3.37 cm <sup>3</sup>
Temperature Range		
Standard Seals.....	-30°~180° F	-35°~80° C
Viton Seals .....	-20°~300° F	-30°~150° C
Actuation Time (180° @ 80PSI/5.5 Bar) .....	0.30 sec.	0.30 sec.
Actuation Time (90° @ 80PSI/5.5 Bar) .....	0.25 sec.	0.25 sec.
End Stop Repeatability .....	±0.02°	±0.02°
End Stop Adjustability .....	23°	23°
Over-Travel (each direction) .....	4°	4°
Valve required to actuate .....	4-way, 2-position	

### UNLESS OTHERWISE NOTED ALL TOLERANCES ARE AS SHOWN BELOW

Dimensions are symmetrical about centerline	Third Angle Projection	All Dowel Holes are SF (Slip Fit). Locational Tolerance ±.0005" or [±.013mm]	Metric Threads Course Pitch	<b>Imperial in.</b> 0.00 = ±.01 0.000 = ±.005 0.0000 = ±.0005	<b>Metric [mm]</b> [0.] = [±.25] [0.0] = [±.13] [0.00] = [±.013]
---	------------------------	---	--------------------------------	--	---

## Loading Information

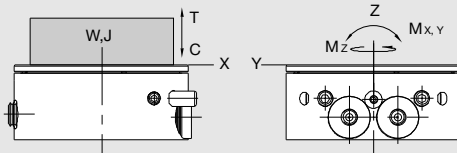

Loading Capacity	Static		Dynamic	
	Imperial	Metric	Imperial	Metric
Maximum Tension <b>T</b>	50 lbs	222 N	10 lbs	44 N
Maximum Compression <b>C</b>	250 lbs	1112 N	50 lbs	222 N
Maximum Moment <b>M<sub>x</sub></b>	100 in.-lbs.	11 Nm	20 in.-lbs.	2 Nm
Maximum Moment <b>M<sub>y</sub></b>	100 in.-lbs.	11 Nm	20 in.-lbs.	2 Nm
Maximum Payload <b>W</b>			1 lbs.	0.45 Kg
Maximum Inertia <b>J</b>			0.0016 in-lb-sec <sup>2</sup>	0.000181 N-m-sec <sup>2</sup>

USE M3 PLUG WHEN USING BOTTOM PORT FOR BOTTOM MANIFOLD. AVAILABLE WITH -M OPTION

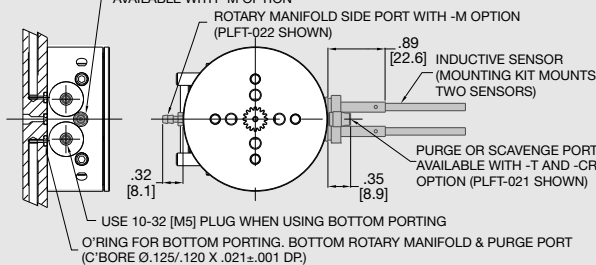

USE 10-32 [M5] PLUG WHEN USING BOTTOM PORTING

O-RING FOR BOTTOM PORTING. BOTTOM ROTARY MANIFOLD & PURGE PORT (C BORE Ø.125/.120 X .021±.001 DP)

## How to Order: (Order Accessories separately from Basic Model)

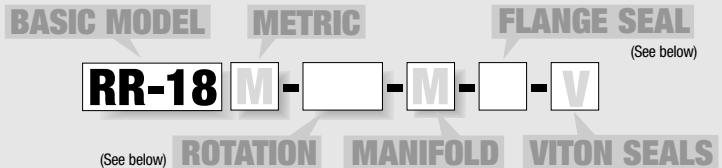

**DEGREE OF ROTATION 45°, 90°, 135°, or 180°**  
(consult factory for intermediate degrees of rotation)

### FLANGE SEAL OPTION -T, -CR

**-T** Sealed Flange, **-CR** Sealed Flange w/Food Grade Grease & Corrosion Resistant Hardware

### SENSOR ACCESSORIES

	STANDARD	METRIC	QTY/UNIT
Sensor Mounting Kit (mounts 2 sensors)	<b>OSMK-024</b>	<b>OSMK-024</b>	<b>1</b>
NPN Inductive Sensor with Quick Disconnect*	<b>OISN-014</b>	<b>OISN-014</b>	<b>1 or 2</b>
PNP Inductive Sensor with Quick Disconnect*	<b>OISP-014</b>	<b>OISP-014</b>	<b>1 or 2</b>
Quick Disconnect 2M Cable Length*	<b>CABL-010</b>	<b>CABL-010</b>	<b>1 or 2</b>
Quick Disconnect 5M Cable Length*	<b>CABL-013</b>	<b>CABL-013</b>	<b>1 or 2</b>

### PNEUMATIC ACCESSORIES

M3 Plumbing Fitting Push-In for 3mm OD Tube	<b>PLFT-021</b>	<b>PLFT-021</b>	<b>2</b>
M3 Plumbing Fitting Barb for 2mm ID Tube	<b>PLFT-022</b>	<b>PLFT-022</b>	<b>2</b>
#10-32 Flow Control	<b>VLVF-007</b>		<b>2</b>
M5 Flow Control		<b>VLVF-008</b>	<b>2</b>
Standard Seal Repair Kit	<b>SLKT-173</b>	<b>SLKT-173</b>	<b>1</b>
Viton Seal Repair Kit	<b>SLKT-173V</b>	<b>SLKT-173V</b>	<b>1</b>
Bottom Air Ports Manifold Seal Kit	<b>SLKT-174V</b>	<b>SLKT-174V</b>	<b>1</b>

\*Sensor and cable sold separately.

Please see back cover for DE-STA-CO Global Locations. [www.destaco.com](http://www.destaco.com)

[www.comoso.com](http://www.comoso.com)



# ROTARY ACTUATORS RR-28M FLANGE OUTPUT SERIES

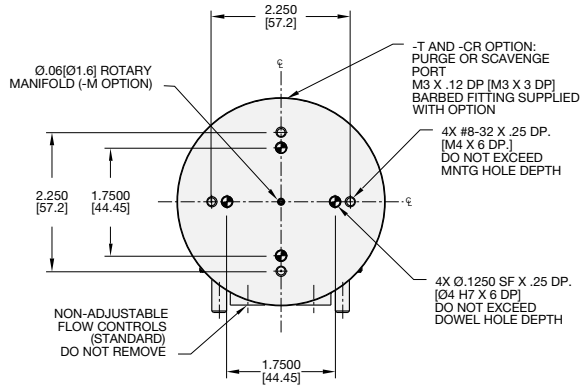

UNIT SHOWN IN 0° POSITION ROTATED FULLY CW

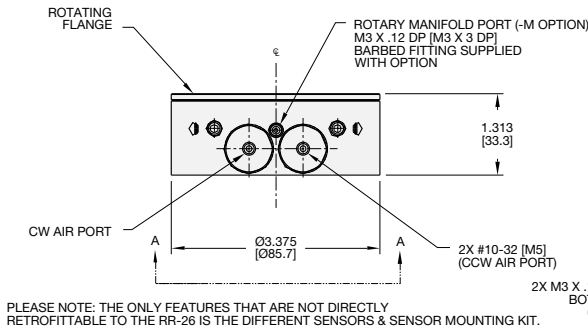

Specifications	RR-28	RR-28M
Maximum Payload.....	3.0 lbs.	1.36 Kg
Maximum Payload Inertia.....	0.0111 in-lb-sec <sup>2</sup>	0.001255 N-m-sec <sup>2</sup>
Maximum Rotation.....	180°	180°
Maximum Torque Mid-Stroke @ 100 PSI.....	22 in-lbs.	2.5 N-m
Maximum Torque End of Stroke @ 100 PSI.....	22 in-lbs.	2.5 N-m
Pitch Diameter of Pinion.....	0.50 in.	12.7 mm
Weight.....	1.44 lbs.	0.65 Kg
Pressure Range.....	30-100 psi	2-7 bar
Bore Ø (2X).....	0.750 in.	19.05 mm
Displacement.....	0.69 in <sup>3</sup>	11.4 cm <sup>3</sup>
Temperature Range		
Standard Seals.....	-30°~180° F	-35°~80° C
Viton Seals.....	-20°~300° F	-30°~150° C
Actuation Time (180° @ 80PSI/5.5 Bar).....	0.35 sec.	0.35 sec.
Actuation Time (90° @ 80PSI/5.5 Bar).....	0.30 sec.	0.30 sec.
End Stop Repeatability.....	±0.02°	±0.02°
End Stop Adjustability.....	23°	23°
Over-Travel (each direction).....	8°	8°
Valve required to actuate.....	4-way, 2-position	

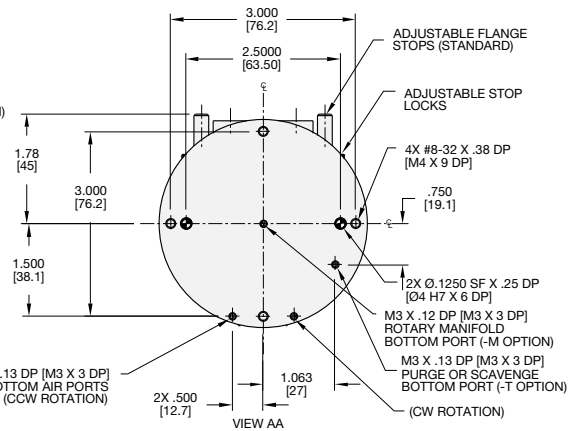

### UNLESS OTHERWISE NOTED ALL TOLERANCES ARE AS SHOWN BELOW

Symbol	Imperial in.	Metric [mm]
	0.00 ± .01	[0.] = ± .25
	0.000 ± .005	[0.0] = ± .13
	0.0000 ± .0005	[0.00] = ± .013

Dimensions are symmetrical about centerline  
Third Angle Projection  
All Dowel Holes are SF (Slip Fit). Locational Tolerance ±.0005" or [±.013mm]  
Metric Threads Course Pitch

## Loading Information

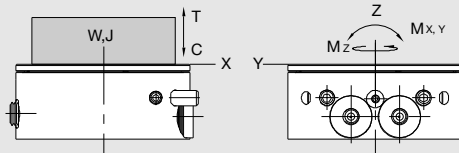

Loading Capacity	Static		Dynamic	
	Imperial	Metric	Imperial	Metric
Maximum Tension <b>T</b>	75 lbs	334 N	15 lbs	67 N
Maximum Compression <b>C</b>	500 lbs	2224 N	100 lbs	445 N
Maximum Moment <b>M<sub>x</sub></b>	250 in.-lbs.	28 Nm	50 in.-lbs.	6 Nm
Maximum Moment <b>M<sub>y</sub></b>	250 in.-lbs.	28 Nm	50 in.-lbs.	6 Nm
Maximum Payload <b>W</b>	3 lbs.		1.36 Kg	
Maximum Inertia <b>J</b>	0.0111 in-lb-sec <sup>2</sup>		0.001255 N-m-sec <sup>2</sup>	

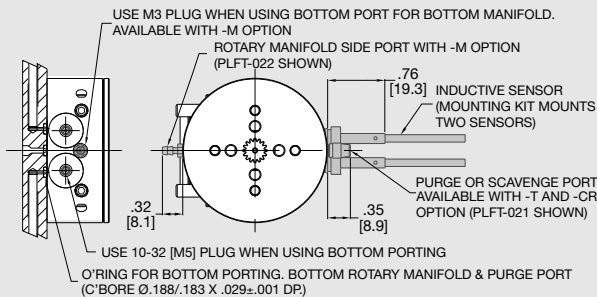

## How to Order: (Order Accessories separately from Basic Model)

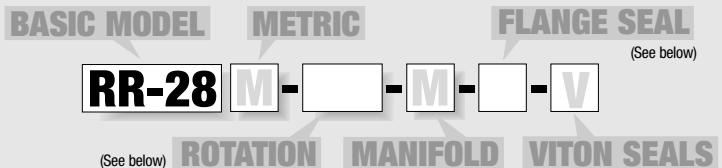

DEGREE OF ROTATION 45°, 90°, 135°, or 180°  
(consult factory for intermediate degrees of rotation)

### FLANGE SEAL OPTION -T, -CR

-T Sealed Flange, -CR Sealed Flange w/Food Grade Grease & Corrosion Resistant Hardware

### SENSOR ACCESSORIES

	STANDARD	METRIC	QTY/UNIT
Sensor Mounting Kit (mounts 2 sensors)	<b>OSMK-024</b>	<b>OSMK-024</b>	<b>1</b>
NPN Inductive Sensor with Quick Disconnect*	<b>OISP-014</b>	<b>OISP-014</b>	<b>1 or 2</b>
PNP Inductive Sensor with Quick Disconnect*	<b>OISP-014</b>	<b>OISP-014</b>	<b>1 or 2</b>
Quick Disconnect 2M Cable Length*	<b>CABL-010</b>	<b>CABL-010</b>	<b>1 or 2</b>
Quick Disconnect 5M Cable Length*	<b>CABL-013</b>	<b>CABL-013</b>	<b>1 or 2</b>

### PNEUMATIC ACCESSORIES

M3 Plumbing Fitting Push-In for 3mm OD Tube	<b>PLFT-021</b>	<b>PLFT-021</b>	<b>2</b>
M3 Plumbing Fitting Barb for 2mm ID Tube	<b>PLFT-022</b>	<b>PLFT-022</b>	<b>2</b>
#10-32 Flow Control	<b>VLVF-007</b>		<b>2</b>
M5 Flow Control		<b>VLVF-008</b>	<b>2</b>
Standard Seal Repair Kit	<b>SLKT-175</b>	<b>SLKT-175</b>	<b>1</b>
Viton Seal Repair Kit	<b>SLKT-175V</b>	<b>SLKT-175V</b>	<b>1</b>
Bottom Air Ports Manifold Seal Kit	<b>SLKT-176V</b>	<b>SLKT-176V</b>	<b>1</b>

\*Sensor and cable sold separately.

Please see back cover for DE-STA-CO Global Locations. [www.destaco.com](http://www.destaco.com)

[www.comoso.com](http://www.comoso.com)

RR SERIES

3.29

# RR-18, -28 Series Exploded View



RR-18 & 28  
SERIES  
MAINTENANCE

3.30

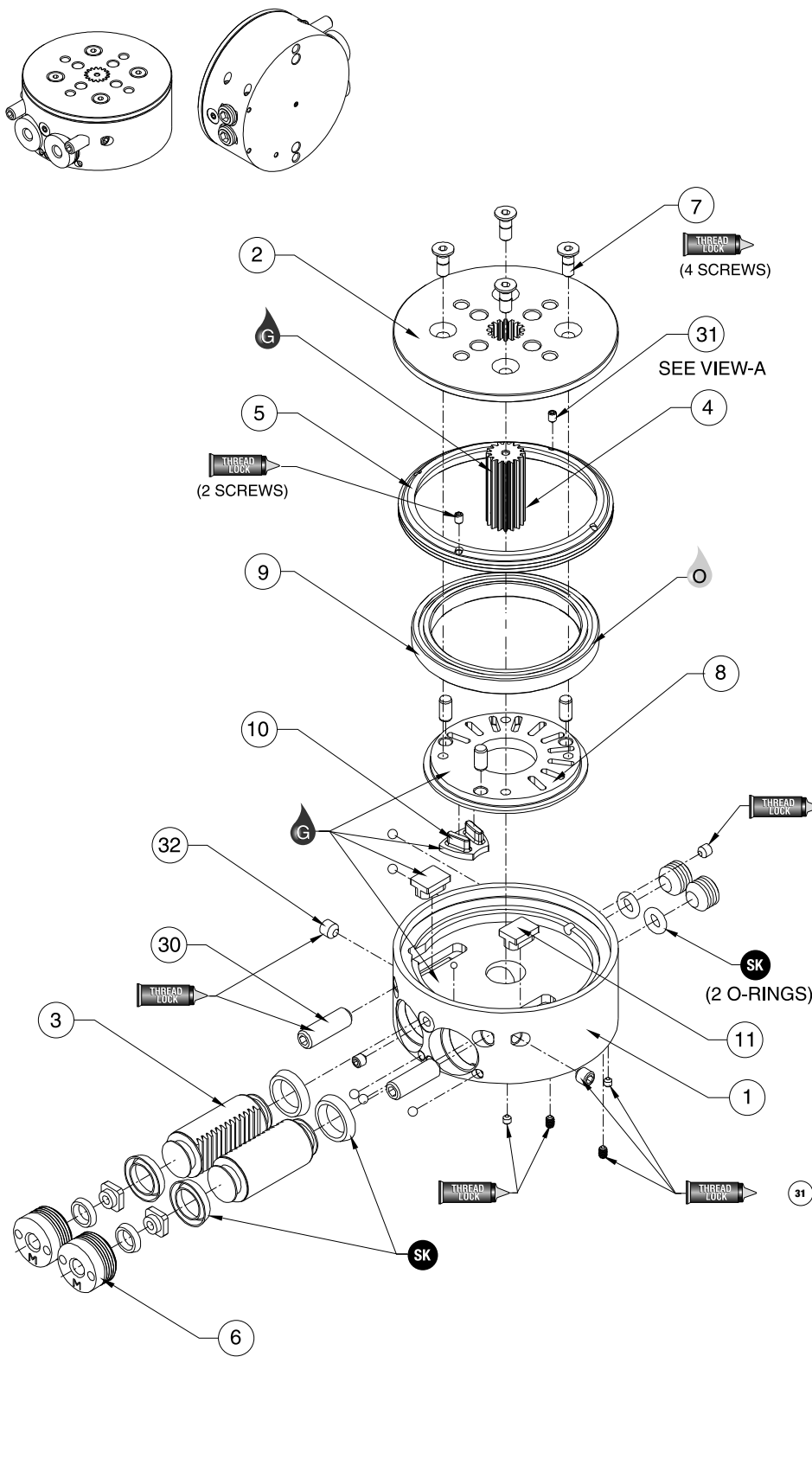

Item	Qty	Name
01	1	Body
02	1	Flange/Turntable
03	2	Rack, Piston
04	1	Pinion
05	1	Lock Nut
06	2	Plug, Flow Control
07	4	Turntable Mounting Screws
08	1	Clamp Plate
09	1	Bearing, Radial
10	1 or 2	Striker
11	2	Puck
30	2	Stop Screw (Stroke Adjustment)
31	2	Sss, Cone Point
32	2	Stop Screw

**NOTE:** Contact the Robohand Sales Department for a complete spare part list with order numbers and prices.

### Assembly Procedure

1. Lubricate and install seals
2. Install racks inside body
3. Install plugs
4. Install stop screws, stop screw locks, and pucks
5. Install striker(s) into desired slot from the chamfer side of the clamp plate and place (striker facing down and away from plugs) onto the pucks.
6. Place bearing over clamp plate and install the lock nut.
7. Using a .035" or 2mm allen wrench, install and lock the 2 cone point set screws (#31) to lock the lock nut in place.
8. Install pinion and dowel pins into turntable and then mate that subassembly to the clamp plate.
9. Install turntable-mounting screws.
10. Fine-tune the stop screws to achieve the desired stroke and then tighten the stop screw locks.

**SK Seal Repair Kit Order #'s  
See Product Data Sheets**

VIEW-A



Seal Kit  
Items



Thread  
Locker



Krytox™  
Lubricant



Lightweight  
Machine Oil



Teflon® Based  
Grease



Super  
Bonder

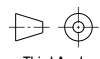

Third Angle  
Projection

Please see back cover for DE-STA-CO Global Locations. [www.destaco.com](http://www.destaco.com)

[www.comoso.com](http://www.comoso.com)

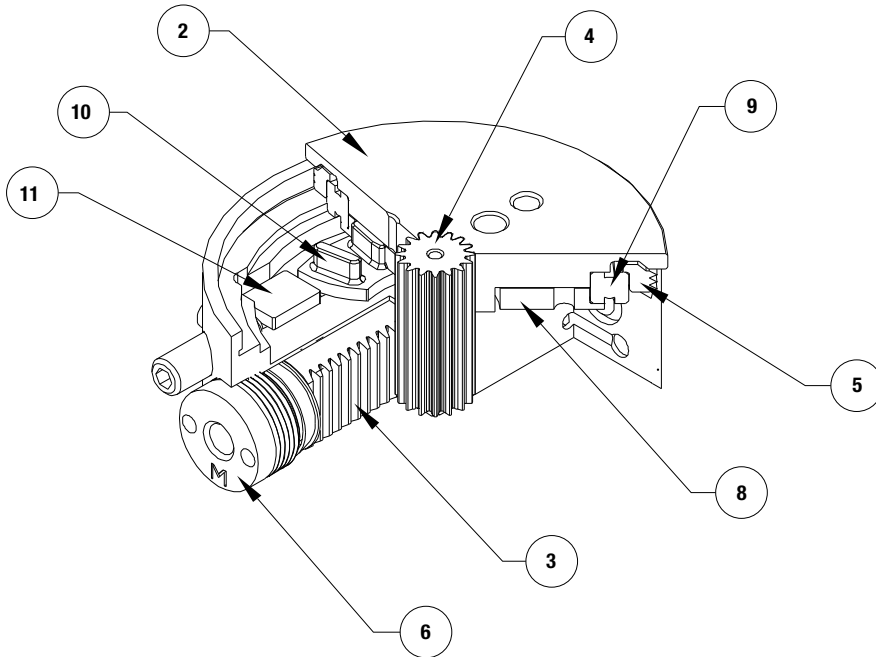

Item	Qty	Name
02	1	Flange/Turntable
03	2	Rack, Piston
04	1	Pinion
05	1	Lock Nut
06	2	Plug, Flow Control
08	1	Clamp Plate
09	1	Bearing, Radial
10	1 or 2	Striker
11	2	Puck
15	1 or 2	Sensor
21	1 or 2	Push-in Fitting
22	1 or 2	Barb Fitting
25	1	Sensor Coupler

**NOTE:** Contact the Robohand Sales Department for a complete spare parts list with order numbers and prices.

## Accessory Installation & Adjustment Instructions

### Installation

For each sensor.

1. Rotate flange so piston rack stops on end stop. Install sensor as shown, pushing in until it stops.
2. Tighten nut.

### Plumbing fittings:

Either the barb fitting or the push-in fitting can be used for any M3 port.

Flow controls (not shown) can be used for the main rotary airports as additional control.

Note: Sensors need to be readjusted when end stops are adjusted.

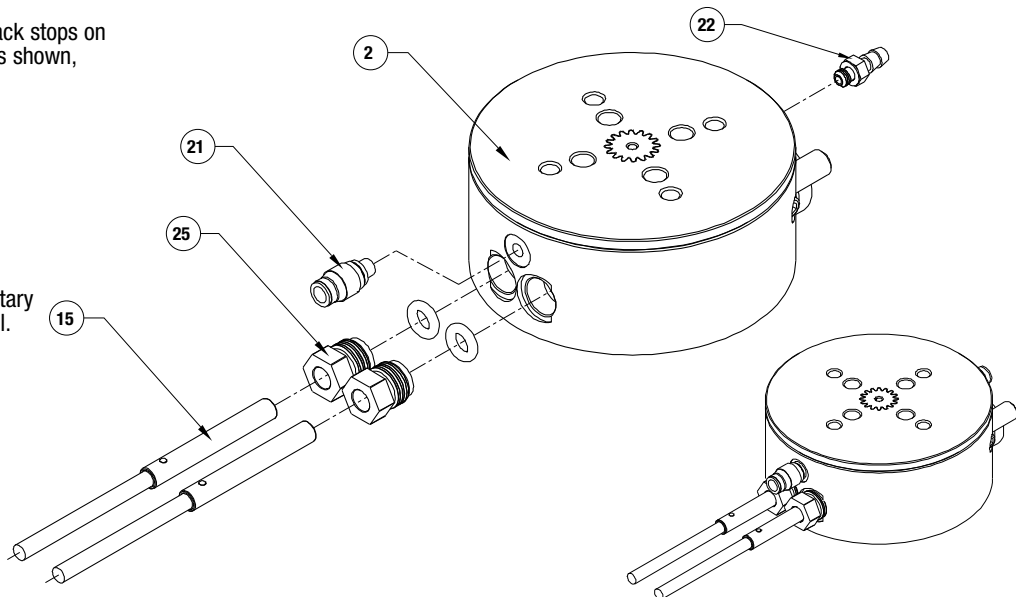

Seal Kit Items



Thread Locker



Krytox™ Lubricant



Lightweight Machine Oil



Teflon® Based Grease



Super Bonder



Third Angle Projection