

Grippers

	Series	Type	Grip force max.	mm or degrees of stroke	Spring open	Spring close	Clean room	Page number
	P5GA	Angular	13N to 194N	-10° to 30°	No	No	No	B282
	P5GB	Parallel	16N to 130N	6mm to 16mm	No	No	No	B284
	P5GV	Parallel	36N	3.2mm to 6.3mm	No	No	Yes	B286
	P5GR	Parallel	120N to 458N	6.4mm to 38.1mm	No	Yes	Yes	B288
	P5GU	Parallel	116N to 160N	6.5mm to 25.4mm	No	No	Yes	B291
	P5GN	Parallel	62N to 445N	1.6mm to 9.5mm	No	No	Yes	B294
	P5GM	Parallel	62N to 445N	4.8mm to 25.4mm	No	No	Yes	B297
	P5GS	Parallel	222N to 800N	19.1mm to 73.5mm	No	No	No	B300
	P5GT	Parallel	178N to 2669N	6.4mm to 50.8mm	No	No	No	B303
	P5GP	Electric	111N	0mm to 25mm	No	No	No	B306
	P5GQ	Electric	445N to 1334N	10mm to 20mm	No	No	No	B308
	P5GW	3-Jaw	682N to 44354N	4.0mm to 35mm	No	Yes	Yes	B310

B

Automation Products
 Actuator Products

Grippers

Slide Tables

Rotary Tables

Escapements

Sensors

Fittings



P5SS Slide Tables

- Combination of dual bore cylinder and linear rail
- Magnetic piston standard
- Rubber bumper standard
- Available with stroke adjusters
- Available with shock absorbers



Operating information

Operating pressure: 1.5 to 7 bar (21.8 to 102 PSIG)
 Temperature range: -5° to 60° C (23° to 140° F)
 Filtration requirements:
 Air filtration: 40 micron or better
 Air lubrication: Not necessary*
 Air humidity: Low moisture content (dry)
 *Addition of lubrication will greatly increase service life

Ordering Information: P5SS Slide Tables

P5	S	S	-	***	D	S	G	***	B	N	A	N	N	N														
Family	Series	Spare		Function	Temperature / Finish	Ports	Stroke	Options	Fitting	Spare	Spare	Spare																
S Slide	S Slide table	-		D Double acting magnetic	S Standard	G BSPP	010 10mm 020 20mm 030 30mm 040 40mm 050 50mm 075 75mm 100 100mm 125 125mm 150 150mm	B No options W With specified options pos 16-20	N None	N None	N None	N None																
<table border="1"> <thead> <tr> <th colspan="2">Bore size</th> </tr> </thead> <tbody> <tr> <td>006</td> <td>6mm bore: 10, 20, 30, 40, 50mm stroke</td> </tr> <tr> <td>008</td> <td>8mm bore: 10, 20, 30, 40, 50, 75mm stroke</td> </tr> <tr> <td>012</td> <td>12mm bore: 10, 20, 30, 40, 50, 75, 100mm stroke</td> </tr> <tr> <td>016</td> <td>16mm bore: 10, 20, 30, 40, 50, 75, 100, 125mm stroke</td> </tr> <tr> <td>020</td> <td>20mm bore: 10, 20, 30, 40, 50, 75, 100, 125, 150mm stroke</td> </tr> <tr> <td>025</td> <td>25mm bore: 10, 20, 30, 40, 50, 75, 100, 125, 150mm stroke</td> </tr> </tbody> </table>															Bore size		006	6mm bore: 10, 20, 30, 40, 50mm stroke	008	8mm bore: 10, 20, 30, 40, 50, 75mm stroke	012	12mm bore: 10, 20, 30, 40, 50, 75, 100mm stroke	016	16mm bore: 10, 20, 30, 40, 50, 75, 100, 125mm stroke	020	20mm bore: 10, 20, 30, 40, 50, 75, 100, 125, 150mm stroke	025	25mm bore: 10, 20, 30, 40, 50, 75, 100, 125, 150mm stroke
Bore size																												
006	6mm bore: 10, 20, 30, 40, 50mm stroke																											
008	8mm bore: 10, 20, 30, 40, 50, 75mm stroke																											
012	12mm bore: 10, 20, 30, 40, 50, 75, 100mm stroke																											
016	16mm bore: 10, 20, 30, 40, 50, 75, 100, 125mm stroke																											
020	20mm bore: 10, 20, 30, 40, 50, 75, 100, 125, 150mm stroke																											
025	25mm bore: 10, 20, 30, 40, 50, 75, 100, 125, 150mm stroke																											

Theoretical force



Tube I.D. (mm)	Piston rod (mm)	Operating direction	Piston area (mm ²)	Operating pressure MPa						
				0.2	0.3	0.4	0.5	0.6	0.7	
6	3	OUT	57	11	17	23	29	34	40	
		IN	42	8	13	17	21	25	29	
8	4	OUT	101	20	30	40	51	61	71	
		IN	75	15	23	30	38	45	53	
12	6	OUT	226	45	68	90	113	136	158	
		IN	170	34	51	68	85	102	119	
16	8	OUT	402	80	121	161	201	241	281	
		IN	302	60	91	121	151	181	211	
20	10	OUT	628	126	188	251	314	377	400	
		IN	471	94	141	188	236	283	330	
25	12	OUT	982	196	295	393	491	589	687	
		IN	756	151	227	302	378	454	529	

* Option K, L & M shock absorber is not available on 6mm bore
 † Option G & H 25mm adjuster is not available on 6mm bore

Sensor part numbers: Page 330.

Selection Flow Chart

Operating conditions	Formula and charts	Selection example
List out the operating conditions according to mounting position and shape of the workpiece	Model used Cushion style Workpiece install position Mounting position Average speed Va (mm/s) Allowable load W (kg) (Figure 1) Overhang Ln (mm) (Figure 2)	Cylinder: P5SS-6-10 Cushion: Cushion pad Workpiece table mounting Mounting: Lateral mounting Average speed: Va = 150mm/s Load: W = 0.3kg L1 = 4mm L2 = 4mm L3 = 4mm

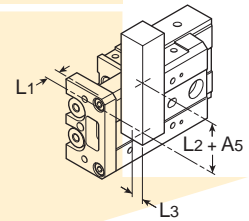

Kinetic energy		
Calculate kinetic energy E(J) of work	$E = 1/2 \cdot W (V/1000)^2$	$E = 1/2 \cdot 0.3 (210/1000)^2 = 0.0066$
Calculate allowable kinetic energy Ea(J)	Collision speed $V = 1.4 \cdot Va$ $Ea = K \cdot Emax$ Workpiece mounting coefficient K: Figure 3	Collision speed $V = 1.4 \cdot 150 = 210$ $Ea = 1 \cdot 0.015 = 0.015$ Possible to use by $E = 0.0066 \leq Ea = 0.015$
Make sure that kinetic energy of work is less / lower than allowable kinetic energy.	Max. allowable kinetic energy Emax: Table 1 Kinetic energy (E) ≤ Allowable kinetic energy (Ea)	

Load rate		
Load rate of work		
Calculate static work Wa(kg)	$Wa = K \cdot \beta \cdot Wmax$ Workpiece mounting coefficient K: Figure 3 Allowable load coefficient β: Figure 4 Maximum allowable moment Wmax: Table 2	$Wa = 1 \times 1 \times 0. = 0.66$ K = 1 β = 1 Wmax = 0.6
Calculate load rate α1 of static work	$\alpha_1 = W/Wa$	$\alpha_1 = 0.3/0.6 = 0.5$
Load rate of static moment		
Calculate static moment M(Nm).	$M = W \times 9.8 (Ln + An)/1000$ Correction value for moment center distance An: Table 3	Yawing Calculate My $My = W \times 9.8 (L1 + A3)/1000 = 0.3 \times 9.8 (4 + 13)/1000 = 0.05$ A3 = 13
Calculate allowable static moment Ma(Nm).	$Ma = K \cdot \gamma \cdot Mmax$ Workpiece mounting coefficient K: Figure 3 Allowable moment coefficient γ: Figure 5 Max. allowable moment Mmax: Table 4	Rolling Calculate Mr $Mr = W \times 9.8 (L3 + A2)/1000 = 0.3 \times 9.8 (5 + 6)/1000 = 0.033$ A2 = 6 Mar = 0.7 (Same value as Ma) Mymax = 0.7
Calculate load rate α2 of static moment	$\alpha_2 = M/Ma$	$\alpha_2 = 0.05/0.7 = 0.072$ $\alpha_2' = 0.033/0.7 = 0.047$
Load rate of kinetic moment		
Calculate kinetic moment Me(Nm).	$Me = 1/3 \cdot We \cdot 9.8 (Ln + An)/1000$ Collision equivalence load $We = \delta \cdot W \cdot V$ δ: Cushion coefficient with cushion pad (Standard) = 4/100 with shock absorber = 1/100	Pitching Calculate Mep $Mep = 1/3 \times 2.52 \times 9.8 \times (5 + 6)/1000 = 0.09$ $We = 4/100 \times 0.3 \times 210 = 2.52$
Calculate allowable kinetic moment Mea(Nm).	Correction value for moment center distance An: Table 3 $Mea = K \gamma Mmax$ Workpiece mounting coefficient t K: Figure 3 Allowable moment coefficient γ: Figure 5 Max. allowable moment Mmax: Table 4	Yawing Calculate Mey $Mey = 1/3 \times 2.52 \times 9.8 \times (4 + 16)/1000 = 0.165$ $We = 2.52$ A4 = 16 Meap = 0.679 (Same value as Meap) K = 1 γ = 0.97 Mpmax = 0.
Calculate load rate α3 of kinetic moment.	$\alpha_3 = Me/Mea$	$\alpha_3 = 0.09/0.679 = 0.13$ $\alpha_3' = 0.165/0.679 = 0.243$
Sum of load rate		
When sum of load rate does not exceed 1, it is possible to use.	$\sum \alpha_n = \alpha_1 + \alpha_2 + \alpha_3 \leq 1$	$\sum \alpha_n = \alpha_1 + \alpha_2 + \alpha_2' + \alpha_3 + \alpha_3' \leq 1$ $= 0.5 + 0.072 + 0.047 + 0.133 + 0.243 = 0.995 \leq 1$ And it is possible to use.

B
Automation Products Actuator Products
Grippers
Slide Tables
Rotary Tables
Escapements
Sensors
Fittings

Table 1: Maximum allowable kinetic energy: Emax (J)

Allowable kinetic energy		
Cushion pad	Shock absorber	Model
0.015	—	P5SS-006
0.023	0.041	P5SS-008
0.05	0.105	P5SS-012
0.104	0.214	P5SS-016
0.153	0.313	P5SS-020
0.232	0.472	P5SS-025

Table 2: Maximum allowable static load: Wmax (kg)

Max. allowable kinetic energy	Model
0.6	P5SS-006
0.8	P5SS-008
2	P5SS-012
3.7	P5SS-016
6	P5SS-020
8.5	P5SS-025

Table 3: Correction value for moment center distance: An (mm) (Refer to Figure 2)

A1	A2	A3	A4	A5	Model
11	6	13	16	16	P5SS-006
11	8	13	20	20	P5SS-008
24	9.5	26	25	25	P5SS-012
27	10.5	30	31	31	P5SS-016
34	15.5	36	38	38	P5SS-020
42	20.5	44	46	46	P5SS-025

Figure 3: Workpiece mounting coefficient: K

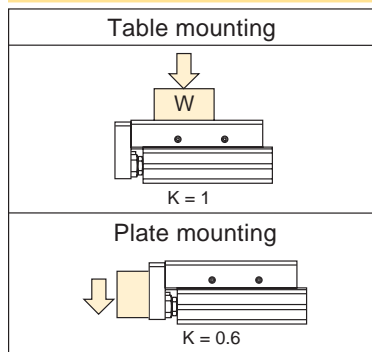

Table 4: Maximum allowable moment: Mmax (Nm)

Stroke (mm)									
10	20	30	40	50	75	100	125	150	Model
0.7	1.0	1.1	1.1	1.1	—	—	—	—	P5SS-006
2.0	2.0	2.6	3.5	3.9	3.9	—	—	—	P5SS-008
3.9	3.9	3.9	5.5	6.8	9.6	9.6	—	—	P5SS-012
9.8	9.8	9.8	9.8	12.0	21.0	30.0	30.0	—	P5SS-016
16.4	16.4	16.4	16.4	24.2	31.4	45.5	45.5	45.5	P5SS-020
26.5	26.5	26.5	26.5	37.8	49.8	62.2	62.2	62.2	P5SS-025

Figure 1: Allowable load: W (kg)

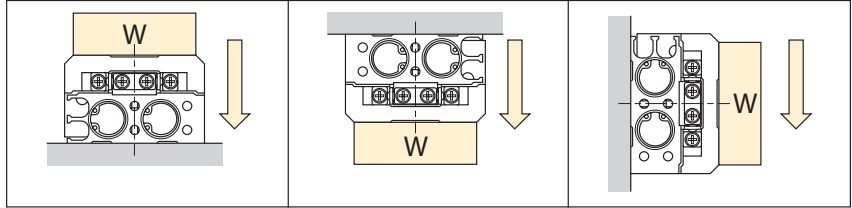
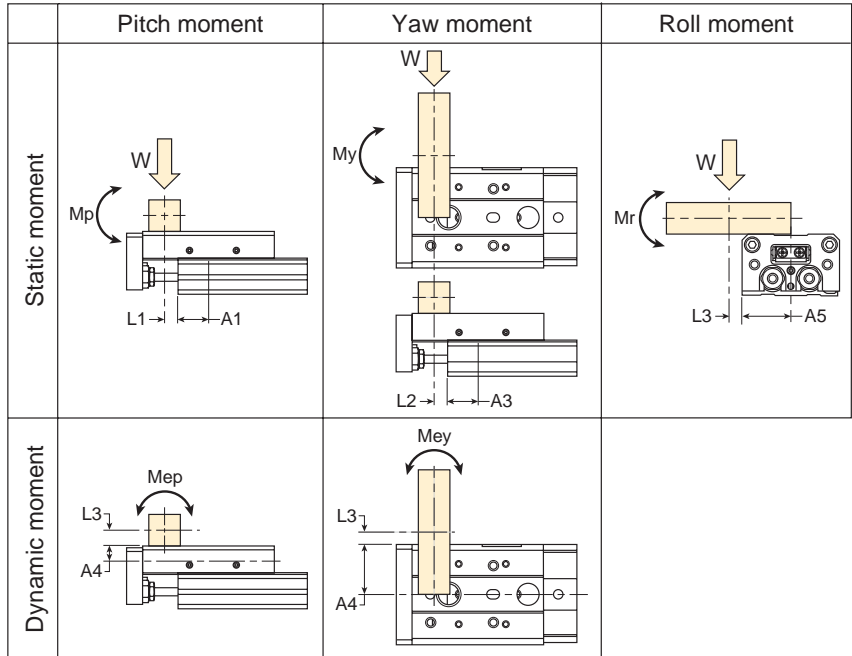

Figure 2: Overhang: Ln (mm) Correction value for moment center distance: An (mm)



Note: Static moment: Moment by gravity.
Kinetic moment: Moment by stopper collision.

Figure 4: Allowable static load coefficient: β

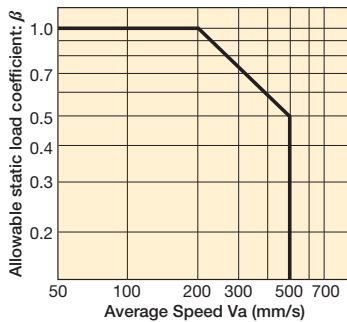
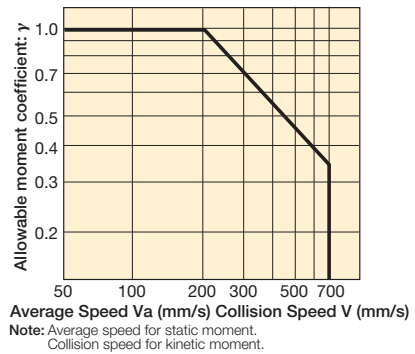

Figure 5: Allowable moment coefficient: γ



Note: Average speed for static moment.
Collision speed for kinetic moment.

Material

Ø 6, Ø 8

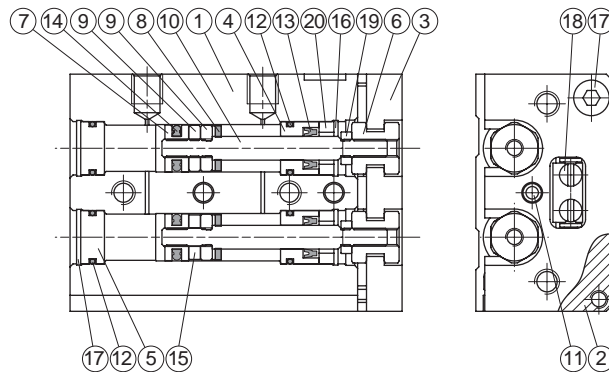

Ø 12 thru Ø 25

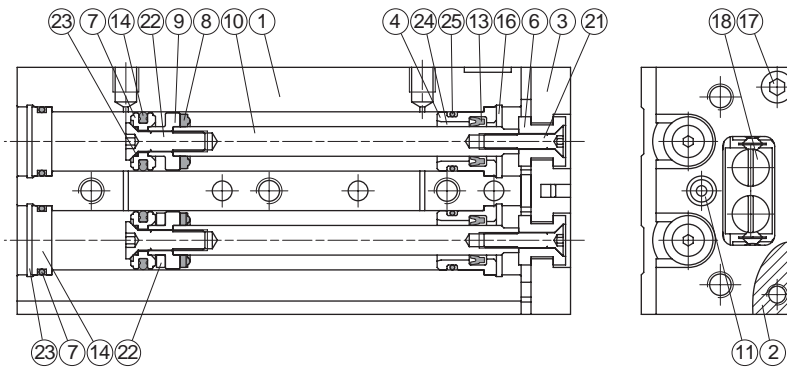

No.	Part name	6	8	12 to 25
1	Body		Aluminum alloy	
2	Table		Aluminum alloy	
3	Plate		Aluminum alloy	
4	Rod cover		Aluminum alloy	
5	Head cover		Aluminum alloy	
6	Floating connector		Stainless steel	
7	Piston		Stainless steel	Aluminum alloy
8	Cushion pad		NBR	
9	Spacer ring	Aluminum alloy	Stainless steel	Aluminum alloy
10	Piston rod		Stainless steel	
11	End cushion		PU	
12	Cover ring		NBR	
13	Rod packing		NBR	

No.	Part name	6	8	12 to 25
14	Piston packing		NBR	
15	Magnet ring		Magnet material	
16	Snap ring	Spring steel	Stainless steel	
17	Bolt		Stainless steel	
18	Slide way		Bearing steel	
19	Nut	Copper	-	
20	Rod cover washer	Stainless steel	-	
21	Floating connector bolt	Stainless steel	-	
22	Piston screw		-	Stainless steel
23	Piston gasket		-	NBR
24	Rod bush		Copper	
25	Cover ring		NBR	

Weight (g)

Stroke (mm)	Tube I.D.					
	Ø6	Ø8	Ø12	Ø16	Ø20	Ø25
10	78	137	335	536	1001	1573
20	98	148	339	546	1012	1587
30	111	171	343	552	1020	1605
40	147	216	393	630	1098	1735
50	172	255	482	723	1254	1930
75	-	367	684	1030	1690	2553
100	-	-	910	1341	2214	3180
125	-	-	-	1646	2729	4082
150	-	-	-	-	3310	4420



Dimensions: P5SS Slide Table - Ø 6

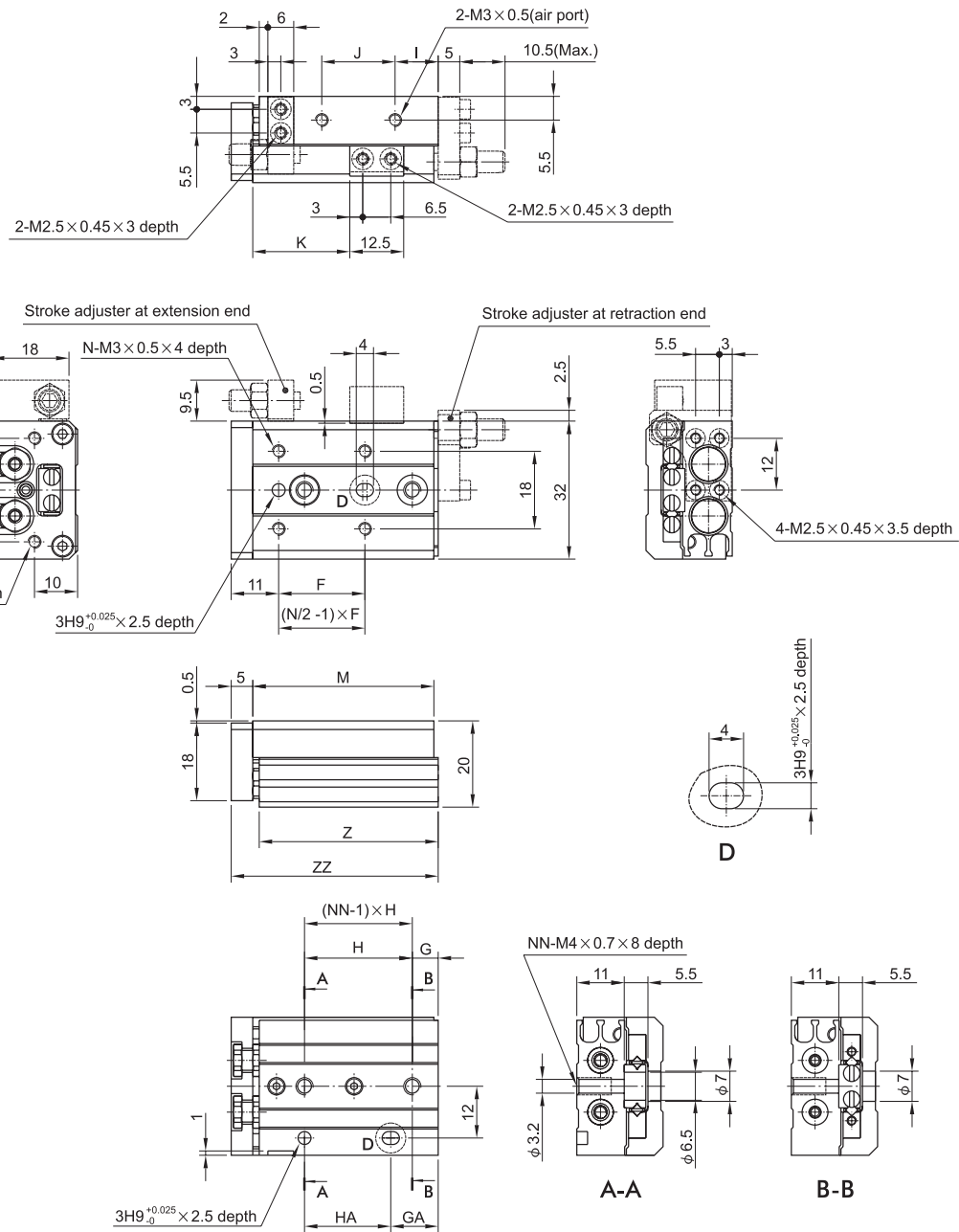

Stroke (mm)	F	G	GA	H	HA	I	J	K	M	N	NN	Z	ZZ
10	20	6	11	25	20	10	17	22.5	42	4	2	41.5	48
20	30	6	21	35	20	10	27	32.5	52	4	2	51.5	58
30	20	11	31	20	20	7	40	42.5	62	6	3	61.5	68
40	28	13	43	30	30	19	50	52.5	84	6	3	83.5	90
50	38	17	41	24	48	25	60	62.5	100	6	4	99.5	106

Dimensions in millimeters

- B**
- Automation Products
- Actuator Products
- Grippers
- Slide Tables
- Rotary Tables
- Escapements
- Sensors
- Fittings



Dimensions: P5SS Slide Table - Ø 8

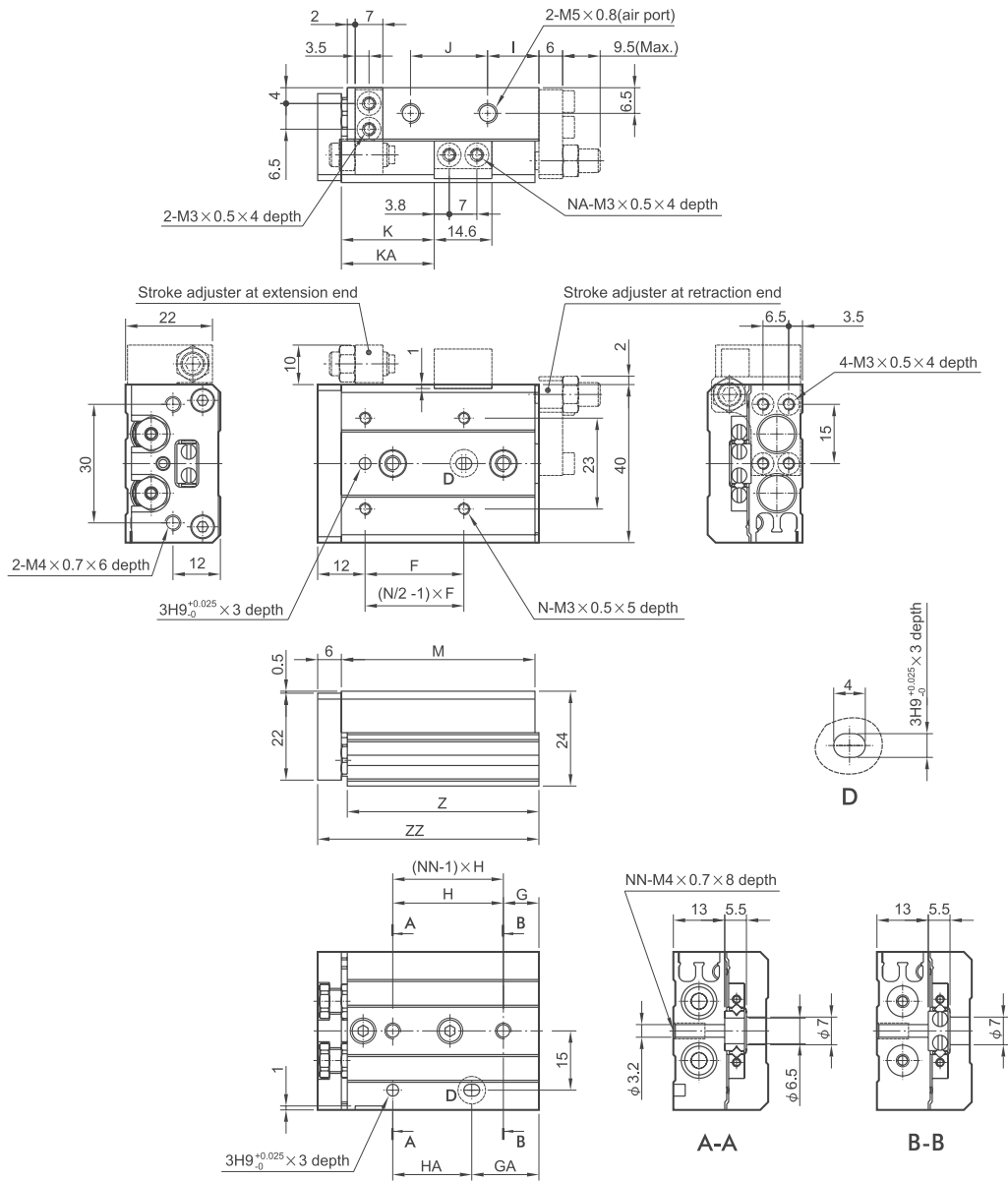

Stroke (mm)	F	G	GA	H	HA	I	J	K	KA	M	N	NA	NN	Z	ZZ
10	25	9	17	28	20	13	19.5	23.5	—	49	4	2	2	48.5	56
20	25	12	12	30	30	8.5	29	33.5	—	54	4	2	2	53.5	61
30	40	13	33	20	20	9.5	39	43.5	—	65	4	2	3	64.5	72
40	50	15	43	28	28	10.5	56	53.5	—	83	4	2	3	82.5	90
50	38	20	43	23	46	24.5	60	63.5	82.5	101	6	4	4	100.5	108
75	50	27	83	28	56	38.5	96	88.5	132.5	151	6	4	5	150.5	158

Dimensions in millimeters

B
 Automation Products
 Actuator Products
 Grippers
 Slide Tables
 Rotary Tables
 Escapements
 Sensors
 Fittings



Dimensions: P5SS Slide Table - Ø 12

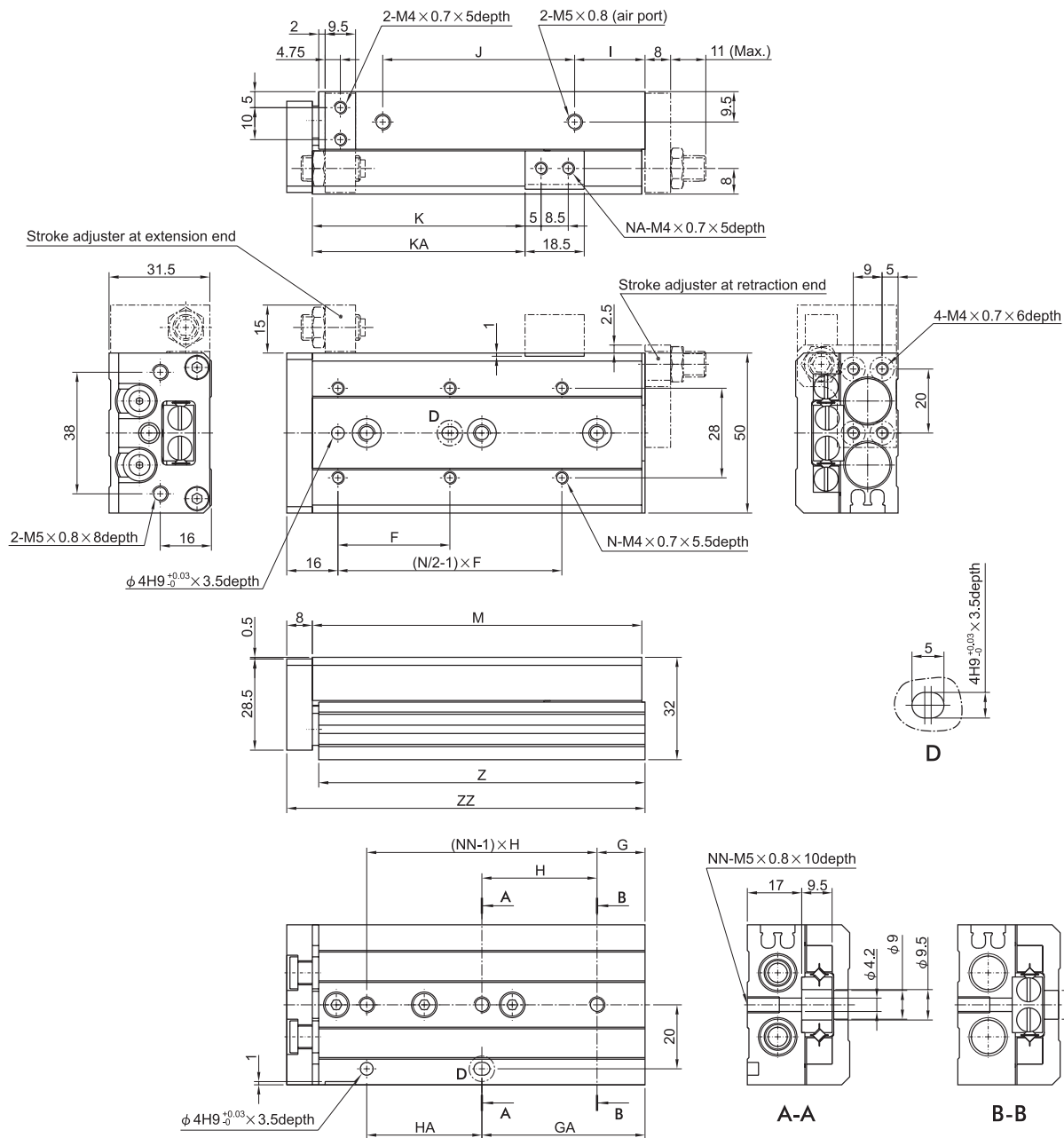

Stroke (mm)	F	G	GA	H	HA	I	J	K	KA	M	N	NA	NN	Z	ZZ
10	35	15	15	40	40	10	40	26.5	—	71	4	2	2	70	80
20	35	15	15	40	40	10	40	36.5	—	71	4	2	2	70	80
30	35	15	15	40	40	10	40	46.5	—	71	4	2	2	70	80
40	50	17	42	25	25	10	52	56.5	—	83	4	2	3	82	92
50	35	15	51	36	36	22	60	66.5	—	103	6	2	3	102	108
75	55	25	61	36	72	43	85	91.5	125.5	149	6	4	4	148	158
100	65	35	111	38	76	52	130	116.5	179.5	203	6	4	5	202	212

Dimensions in millimeters

- B**
- Automation Products
- Actuator Products
- Grippers
- Slide Tables
- Rotary Tables
- Escapements
- Sensors
- Fittings



Dimensions: P5SS Slide Table - Ø 16

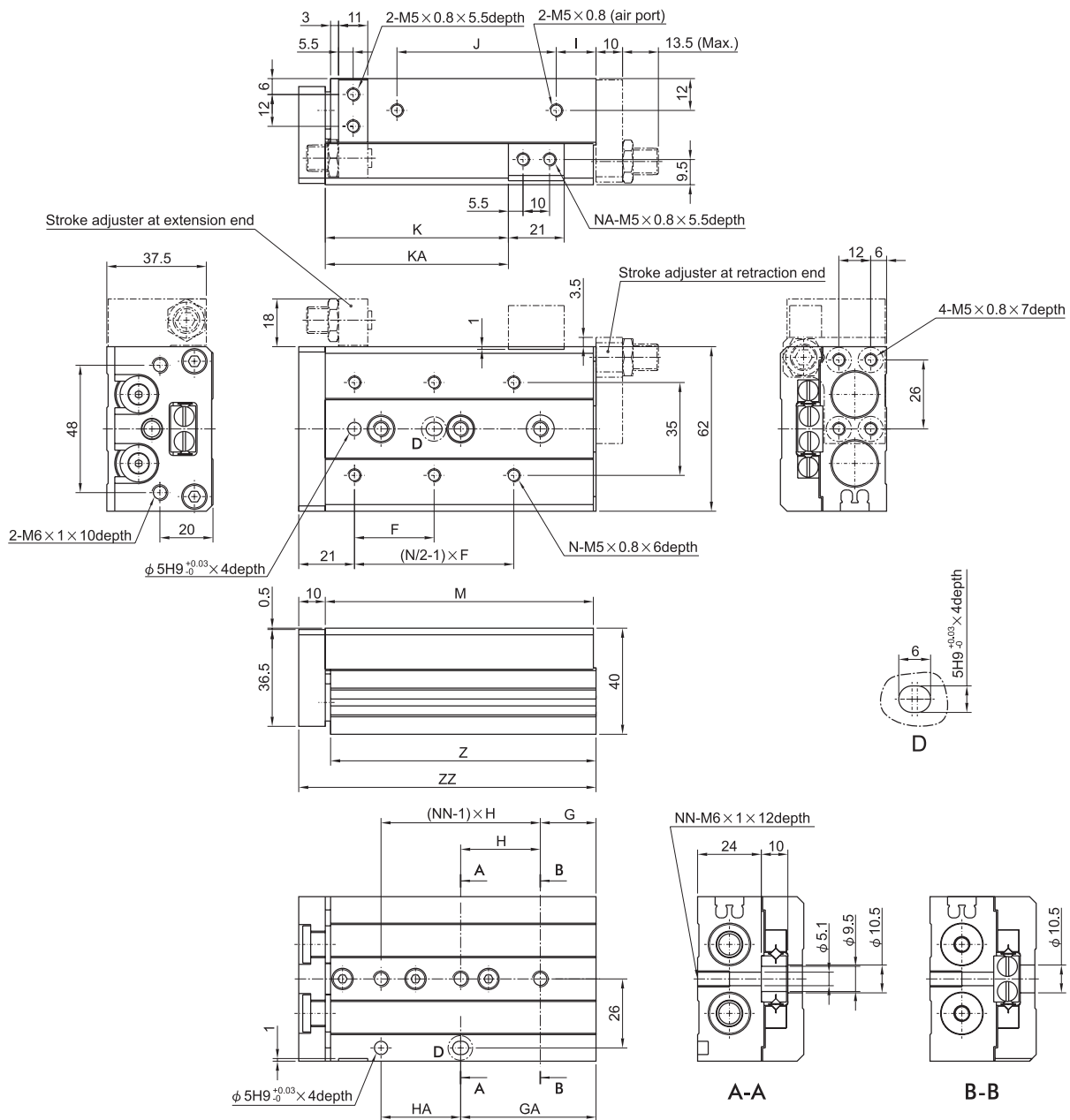

Stroke (mm)	F	G	GA	H	HA	I	J	K	KA	M	N	NA	NN	Z	ZZ
10	35	16	16	40	40	10	40	29	—	76	4	2	2	75	87
20	35	16	16	40	40	10	40	39	—	76	4	2	2	75	87
30	35	16	16	40	40	10	40	49	—	76	4	2	2	75	87
40	40	16	16	50	50	10	50	59	—	86	4	2	2	85	97
50	30	21	51	30	30	15	60	69	—	101	6	2	3	100	112
75	55	26	61	35	70	40	85	94	125	151	6	4	4	150	162
100	65	39	109	35	70	55	118	119	173	199	6	4	5	198	210
125	70	19	159	35	70	68	155	144	223	249	8	4	7	248	260

Dimensions in millimeters



Dimensions: P5SS Slide Table - Ø 20

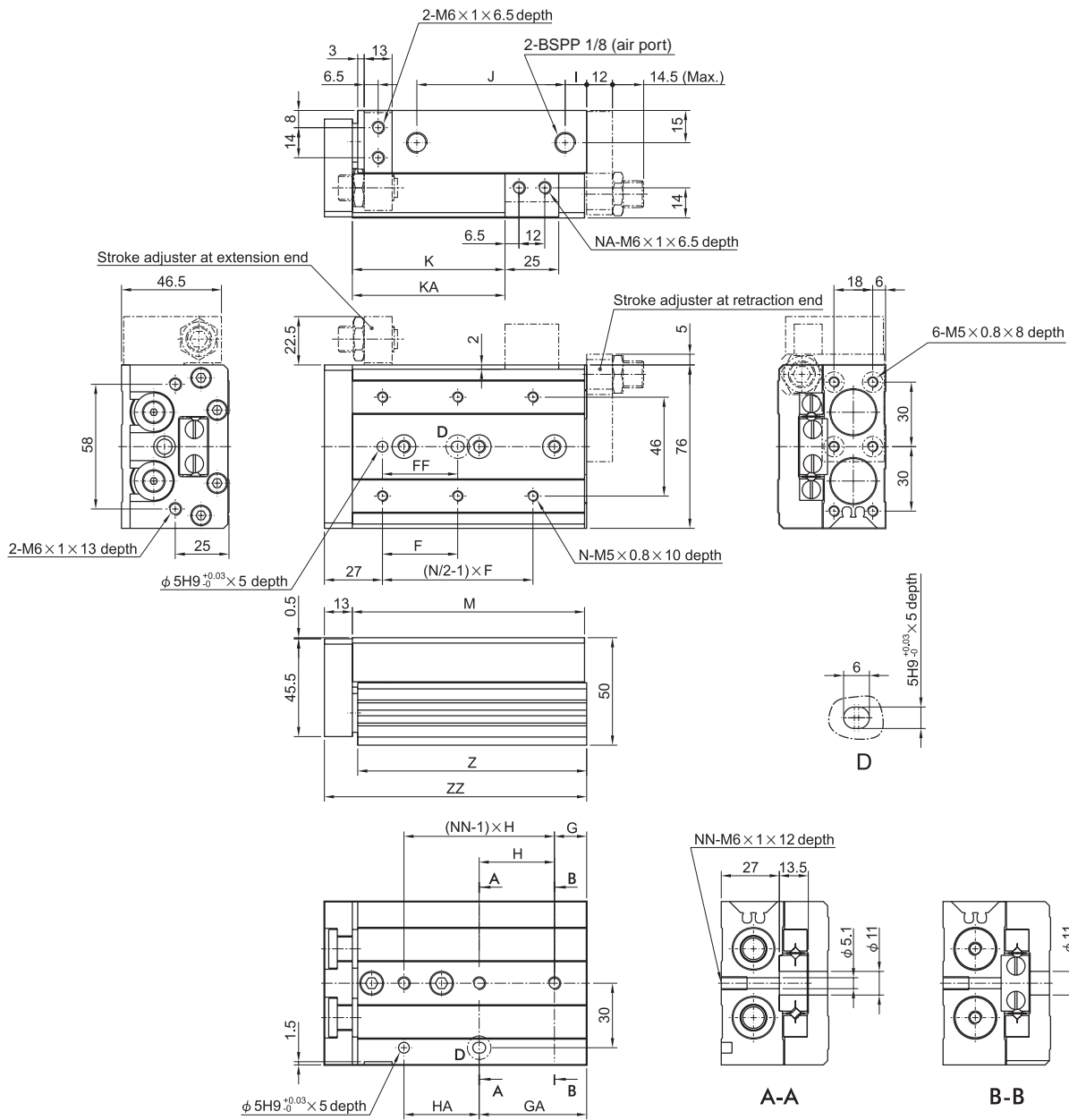

Stroke (mm)	F	FF	G	GA	H	HA	I	J	K	KA	M	N	NA	NN	Z	ZZ
10	50	40	15	25	45	35	10	44	31	—	83	4	2	2	81.5	97
20	50	40	15	25	45	35	10	44	41	—	83	4	2	2	81.5	97
30	50	40	15	25	45	35	10	44	51	—	83	4	2	2	81.5	97
40	60	50	15	35	55	35	10	54	61	—	93	4	2	2	91.5	107
50	35	35	15	50	35	36	10	69	71	—	108	6	2	3	106.5	122
75	60	60	19	54	35	70	10	108	96	—	147	6	2	4	145.5	161
100	70	70	37	107	35	70	58	113	121	169	200	6	4	5	198.5	214
125	70	70	41	155	38	76	70	155	146	223	254	8	4	6	252.5	268
150	80	80	19	195	44	88	87	190	171	275	306	8	4	7	304.5	320

Dimensions in millimeters



B
 Automation Products
 Actuator Products
 Grippers
 Slide Tables
 Rotary Tables
 Escapements
 Sensors
 Fittings

Dimensions: P5SS Slide Table - Ø 25

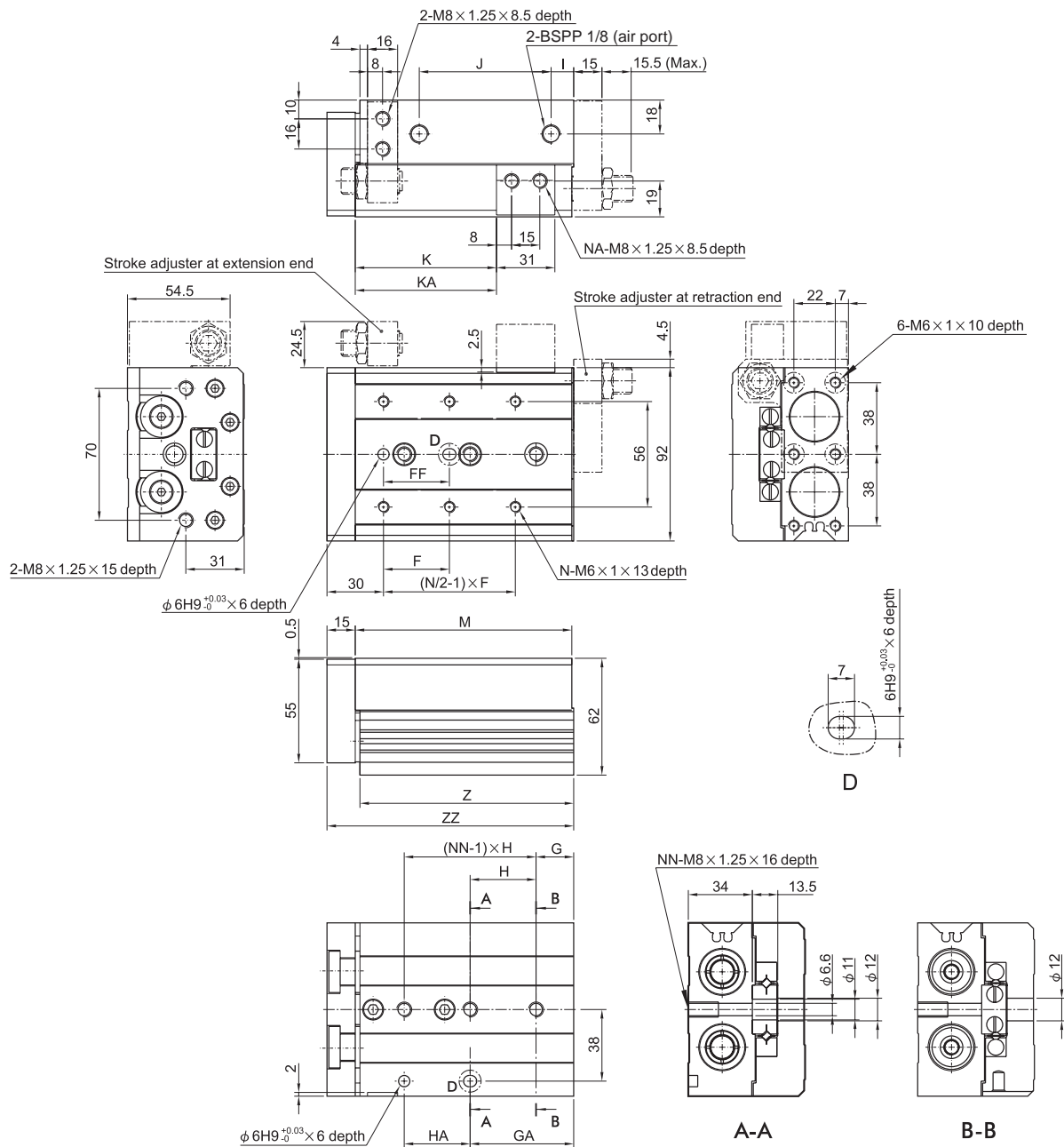

Stroke (mm)	F	FF	G	GA	H	HA	I	J	K	KA	M	N	NA	NN	Z	ZZ
10	50	40	22	22	45	45	12	47	35	—	92	4	2	2	90.5	108
20	50	40	22	22	45	45	12	47	45	—	92	4	2	2	90.5	108
30	50	40	22	22	45	45	12	47	55	—	92	4	2	2	90.5	108
40	60	50	22	22	55	55	12	57	65	—	102	4	2	2	100.5	118
50	35	35	20	55	35	35	12	70	75	—	115	6	2	3	113.5	131
75	60	60	26	61	35	70	33	90	100	—	156	6	2	4	154.5	172
100	70	70	32	102	35	70	50	114	125	162	197	6	4	5	195.5	213
125	75	75	40	154	38	76	67	155	150	218	255	8	4	6	253.5	271
150	80	80	30	190	40	80	82	180	175	258	295	8	4	7	293.5	311

Dimensions in millimeters



Stroke Adjusters

Stroke Adjuster at Extension End

Mounted to Body

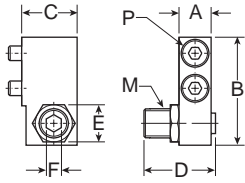

Mounted to Table

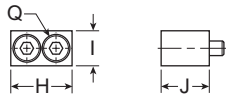

Tube I.D.	Part number	Adjustable stroke range (mm)	Mounted to body								Mounted to table							
			A	B	C	D	E	F	M	P*	H	I	J	Q*				
6	P5SS-006-EA-05	5				16.5												
	P5SS-006-EA-15	15	6	17.8	10.5	26.5	7	2.5	M5 x .08	M2.5 x 10	12.5	6	8.5	M2.5 x .08				
8	P5SS-008-EA-05	5				16.5												
	P5SS-008-EA-15	15	7	21.5	11	26.5	8	3	M6 x 1	M3 x 10	14.6	7	10	M3 x 10				
	P5SS-008-EA-25	25				36.5												
12	P5SS-012-EA-05	5				20												
	P5SS-012-EA-15	15	9.5	31	16	30	11	4	M8 x 1	M4 x 16	18.5	10	13	M4 x 12				
16	P5SS-016-EA-05	5				24.5												
	P5SS-016-EA-10	15	11	37	19	34.5	14	5	M10 x 1	M5 x 16	21	12	16.5	M5 x 16				
20	P5SS-020-EA-05	5				27.5												
	P5SS-020-EA-15	15	13	45.5	24	37.5	17	6	M12 x 1.25	M6 x 20	25	13	21	M6 x 20				
25	P5SS-025-EA-05	5				32.5												
	P5SS-025-EA-15	15	16	53.5	26.5	42.5	19	6	M14 x 1.5	M8 x 25	31	17	25.5	M8 x 25				
	P5SS-025-EA-25	25				52.5												

*Size of hexagon socket head cap screws

Stroke Adjuster at Retraction End

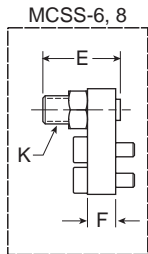
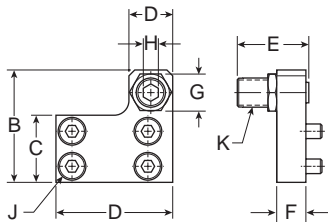

Tube I.D.	Part number	Adjustable stroke range (mm)	Mounted to body															
			A	B	C	D	E	F	G	H	J*	K						
6	P5SS-006-RA-05	5					16.5											
	P5SS-006-RA-15	15	21	19	10.5	8	26.5	5	7	2.5	M2.5 x 8	M5 x .08						
8	P5SS-008-RA-05	5					16.5											
	P5SS-008-RA-15	15	25	22.5	12.5	9	26.5	6	8	3	M3 x 10	M6 x 1						
	P5SS-008-RA-25	25					36.5											
12	P5SS-012-RA-05	5					20											
	P5SS-012-RA-15	15	32	31	18.5	13	30	8	12	4	M4 x 8	M8 x 1						
16	P5SS-016-RA-05	5					24.5											
	P5SS-016-RA-15	15	40	38.5	12	15	34.5	10	14	5	M5 x 10	M10 x 1						
20	P5SS-020-RA-05	5					27.5											
	P5SS-020-RA-15	15	50	48	29	21	37.5	12	17	6	M5 x 12	M12 x 1.25						
25	P5SS-025-RA-05	5					32.5											
	P5SS-025-RA-15	15	60	58	35	23	42.5	15	19	6	M6 x 16	M14 x 1.5						
	P5SS-025-RA-25	25					52.5											

*Size of hexagon socket head cap screws

B
 Automation Products
 Actuator Products

Grippers

Slide Tables

Rotary Tables

Escapements

Sensors

Fittings

Shock Absorbers

Shock Absorber at Extension End

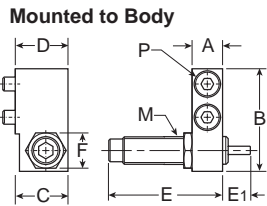

Mounted to Table

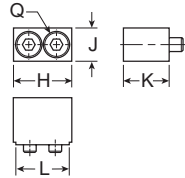

Tube I.D.	Part number	Mounted to body										Mounted to table				
		A	B	C	D	E	E1	F	M	P*	H	J	K	L	Q*	
8	P5SS-008-ESK	7	23	14	15.5	40.8	8	11	M8 x 1	M3 x 16	16.6	7	15.5	14.6	M3 x 16	
12	P5SS-012-ESK	9.5	31	14.5	16	40.8	8	11	M8 x 1	M4 x 16	20.5	10	15	18.5	M4 x 12	
16	P5SS-016-ESK	11	37	17.5	19	43.2	6.6	12.7	M10 x 1	M5 x 16	23	12	18.5	21	M5 x 16	
20	P5SS-020-ESK	13	45.5	23.5	26	86.6	12.7	19	M14 x 1.5	M6 x 25	25.5	13	25.5	25	M6 x 25	
25	P5SS-025-ESK	16	53.5	23.5	26.5	86.6	12.7	19	M14 x 1.5	M8 x 25	25.5	17	25.5	31	M8 x 25	

*Size of hexagon socket head cap screws

Shock Absorber at Retraction End

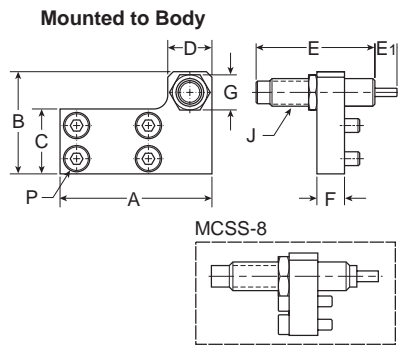

Mounted to Table

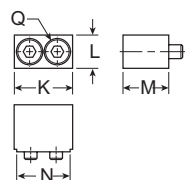

Tube I.D.	Part number	Mounted to body										Mounted to table				
		A	B	C	D	E	E1	F	G	M	P*	K	L	M	N	Q*
8	P5SS-008-RSK	38	23	12.5	14	40.8	8	8	12	M8 x 1	M3 x 12	16.6	7	15.5	14.6	M3 x 16
12	P5SS-012-RSK	45	31	18	14	40.8	8	8	11	M8 x 1	M4 x 8	20.5	10	15	18.5	M4 x 12
16	P5SS-016-RSK	55	37	23.5	16	43.2	6.6	10	12.7	M10 x 1	M5 x 10	23	12	18.5	21	M5 x 16
20	P5SS-020-RSK	70	47	29	23	86.6	12.7	12	19	M14 x 1.5	M5 x 12	25.5	13	25.5	25	M6 x 25
25	P5SS-025-RSK	80	54	35	23	86.6	12.7	15	19	M14 x 1.5	M6 x 16	25.5	17	25.5	31	M8 x 25

*Size of hexagon socket head cap screws

B

Automation Products
 Actuator Products

Grippers

Slide Tables

Rotary Tables

Escapements

Sensors

Fittings

Sensors

Magnetic

Series	PNP with quick disconnect M8	NPN with quick disconnect M8	PNP with quick disconnect (90 degrees) M8	NPN with quick Disconnect (90 Degrees) M8	Page
P5GM	P8S-HHSP-017	P8S-HHSN-017	P8S-HHSP-011	P8S-HISN-011	B332
P5GN	P8S-HHSP-017	P8S-HHSN-017	P8S-HHSP-011	P8S-HISN-011	B332
P5GP	P8S-HHSP-017	P8S-HHSN-017	NA	NA	B332
P5GQ	P8S-HHSP-017	P8S-HHSN-017	NA	NA	B332
P5GR	P8S-HHSP-017	P8S-HHSN-017	P8S-HHSP-011	P8S-HISN-011	B332
P5GS	P8S-HHSP-017	P8S-HHSN-017	P8S-HHSP-011	P8S-HISN-011	B332
P5GT	NA	NA	NA	NA	
P5GU	P8S-HHSP-017	P8S-HHSN-017	NA	NA	B332
P5GV	NA	NA	NA	NA	B332
P5GW	P8S-HHSP-017	P8S-HHSN-017	P8S-HHSP-011	P8S-HISN-011	B332
P5MD	P8S-HHSP-017	P8S-HHSN-017	NA	NA	B332

Inductive

Series	PNP M8 disconnent	NPN M8 disconnect	PNP M12 disconnent	NPN M12 disconnect	Inductive sensor mounting kit	Page
P5GR-010	P8S-HISP-014	P8S-HISN-014	NA	NA	P8S-HSMK-119	B333
P5GR-014					P8S-HSMK-119	
P5GR-021					P8S-HSMK-120	
P5GS-016	P8S-HISP-019	P8S-HISN-019	NA	NA	P8S-HSMK-116	
P5GS-024					P8S-HSMK-117	
P5GS-032					P8S-HSMK-118	
P5GT-025	P8S-HISP-019	P8S-HISN-019	NA	NA	P8S-HSMK-003	
P5GT-025					P8S-HSMK-003	
P5GT-032					P8S-HSMK-003	
P5GT-046	P8S-HISP-011	P8S-HISN-011	NA	NA	P8S-HSMK-072	B332
P5GT-064					P8S-HSMK-072	
P5GT-089					P8S-HSMK-073	
P5GW-072	P8S-HISP-011	P8S-HISN-011	NA	NA	NA	B332
P5GW-95					NA	
P5GW-120					NA	
P5GW-156	NA	NA	P8S-HISN-017	P8S-HISP-017	NA	B333
P5GW-220					NA	

Sensors for Economy Grippers, Slide Tables, Rotary Tables

Series	Reed switch 5-120 V AC/DC	Reed switch 5-120 V AC/DC M8	NPN 5-30 VDC	NPN 5-30 VDC M8	PNP 5-30 VDC	PNP 5-30 VDC M8	Page
P5SS	P8S-ERFXS	P8S-ERSUS	P8S-ENFXS	P8S-ENSUS	P8S-EPFXS	P8S-EPSUS	B331
P5GA	P8S-ERFXS	P8S-ERSUS	P8S-ENFXS	P8S-ENSUS	P8S-EPFXS	P8S-EPSUS	B331
P5GB	P8S-ERFXS	P8S-ERSUS	P8S-ENFXS	P8S-ENSUS	P8S-EPFXS	P8S-EPSUS	B331
P5RS	P8S-FRFXS	P8S-FRSUS	P8S-FNFXS	P8S-FNSUS	P8S-FPFXS	P8S-FPSUS	B331

Cables

2 meter cable M8	5 meter cable M8	2 meter cable M12	5 meter cable M12
P8S-CABL-010	P8S-CABL-013	P8S-CABL-014	P8S-CABL-018



Model	P8S-FRFXS P8S-FRSUS (M8)	P8S-FNFXS	P8S-FPFXS
Wiring method	2 wire	3 wire	
Switching logic	SPST normally open	Solid state output, normally open	
Switch type	Reed switch	NPN current sinking	PNP current sourcing
Operating voltage	5 to 120 V DC/AC	5 to 30 VDC	
Switching voltage	100 mA max.	200 mA max.	
Contact rating	10 W max.	6 W max.	
Current consumption	—	8 mA @ 24 V max. (Switch active)	
Voltage drop	3.5 V max.	1 V @ 200 mA max.	
Leakage current	—	0.01 mA max.	
Indicator	Red LED	Red LED	Green LED
Cable	2.8 Ø, 2C	2.8 Ø, 3C	
Magnet frequency (1)	60 Gauss	40 Gauss	
Temperature range	-10°C to 70°C (14°F to 158°F)		
Shock (2)	30 G	50 G	
Vibration (3)	9 G		
Enclosure classification	IEC 529, IP67		
Protection circuit	None	Power source reverse polarity; surge suppression	
Connect diagram			

- (1) Measuring standard target: Ø 15.5 x Ø 8 x 5t (Anisotropy rubber magnet).
- (2) Sine wave / X.Y.Z 3 directions / 3 times each direction / 11ms each time.
- (3) Double amplitude 1.5 mm / 10 Hz -55 Hz-10 Hz (Sweep 1min / X.Y.Z. 3 directions / 1 hour each time.

Model	P8S-ERFXS P8S-ERSUS (M8)	P8S-ENFXS P8S-ENSUS (M8)	P8S-EPFXS P8S-EPSUS (M8)
Switch type	Reed switch	NPN current sinking	PNP current sourcing
Contacts	Normal open		
Voltage range	5 to 120 V DC/AC	5 to 30 VDC	
Current range	100 mA max.	50 mA max.	
Contact rating	6 W max.	1.5 W max.	
Shock resistance	30 G	50 G	
Voltage drop	0.5 V max.	1.5V max.	
Response time	Max. 1 ms		
Temperature range	-10°C to 70°C (14°F to 158°F)		
Lead wire	2.8 Ø, 3C	3.0 Ø, 3C, PU	
Lead wire length	2 m		
Indicator lamp	LED lights up when ON		
Enclosure classification	IP67 (NEMA 6)		IEC 529, IP67
Indicator	Red LED		Green LED
Connect diagram			

Wiring of the QD

2 wire QD wiring

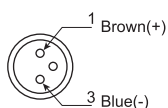

3 wire QD wiring

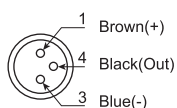

P8S-HHSP-011 and P8S-HISN-011 Sensors

P8S-HHSP-011 ↔ P8S-HISN-011

Description: Solid state magnetoresistive (MR) sensor
Function: PNP (N.O.) or NPN (N.O.)
Voltage supply range: 4.5 - 30 VDC
Current consumption: Max. 9 mA @ 24 V
Voltage drop: Max. 1.2 V
Max. switching current: 50 mA
Reverse polarity protection: Yes
Short circuit (transient) protection: Yes
Temperature range: -10°C to 70°C (14°F to 158°F)
Protection class: IP67
Response frequency: 1 kHz

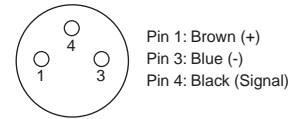

P8S-HHSP-011

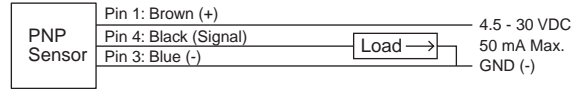

P8S-HISN-011

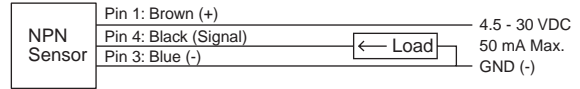

P8S-HHSP-017 and P8S-HHSN-017 Sensors

P8S-HHSP-017 ↔ P8S-HHSN-017

Description: Magnetoresistive 4mm Dovetail
Function: PNP (N.O.) or NPN (N.O.)
Voltage supply range: 4.5 - 28 VDC
Current consumption: Max. 10 mA @ 24 V
Voltage drop: Max. 0.5 V
Max. switching current: 100 mA
Reverse polarity protection: Yes
Short circuit (transient) protection: Yes
Temperature range: -10°C to 70°C (14°F to 158°F)
Protection class: IP67
Response frequency: 1 kHz
Hysteresis: <0.2 mm
Repeatability: <0.1 mm
Insulation resistance: Min 100 M OHM (Lead to case @ 500 VDC)
Withstand voltage: (Lead to case) 1000 VAC RMS for 1 min or 1500 VAC RMS for 2 sec

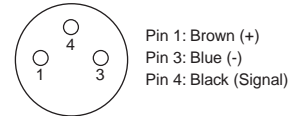

P8S-HHSP-017

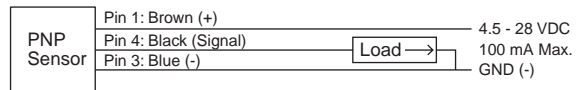

P8S-HHSN-017

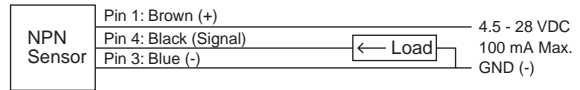

P8S-HISP-011 and P8S-HISN-011 Sensors

P8S-HISP-011 ↔ P8S-HISN-011

Description: Inductive 8mm proximity sensor
Connection: 3-pole quick disconnect
Function: PNP (N.O.) or NPN (N.O.)
Indicator: LED
Load current: 200 mA max.
Internal voltage drop: < 1 V
Current consumption: 15 mA max.
Operating voltage: 5 - 30 VDC
Reverse polarity protection: Yes
Response frequency: 800 - 1000 Hz
Relative humidity: 35 - 95%
Shielded design: Yes
Sensing range: 1.5 mm
Temperature range: -25°C to 7°C (-13°F to 45°F)
NEMA rating: 6
IEC rating: IP67
Ratings: CE, ISO 9001

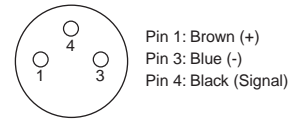

P8S-HISP-011

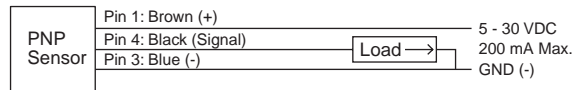

P8S-HISN-011

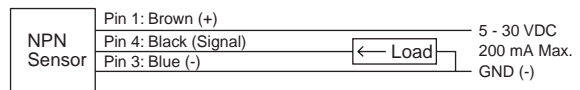

B

Automation Products
 Actuator Products

Grippers

Slide Tables

Rotary Tables

Escapements

Sensors

Fittings

P8S-HISP-014 and P8S-HISN-014 Sensors

P8S-HISP-014 ↔ P8S-HISN-014

Description: Inductive 4mm proximity sensor
Connection: 3-pole quick disconnect
Function: PNP (N.O.) or NPN (N.O.)
Indicator: LED
Load current: 100 mA max.
Internal voltage drop: < 2.5 V
Current consumption: 18 mA
Operating voltage: 10 - 30 VDC
Reverse polarity protection: Yes
Response frequency: 5 kHz
Relative humidity: 35 - 95%
Shielded design: Yes
Sensing range: 1.0 mm
Temperature range: -25°C to 75°C (-13°F to 167°F)
NEMA rating: 6
IEC rating: IP67
Ratings: CE, ISO 9001

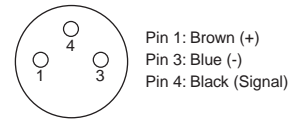

P8S-HISP-014

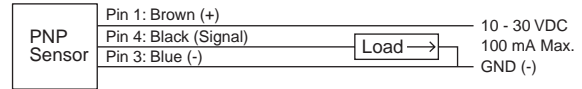

P8S-HISN-014

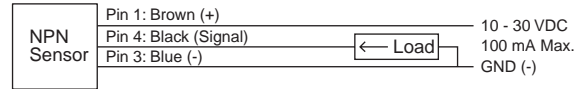

P8S-HISP-017 and P8S-HISN-017 Sensors

P8S-HISP-017 ↔ P8S-HISN-017

Description: Inductive 12mm proximity sensor
Connection: 4-pole quick disconnect
Function: PNP (N.O.) or NPN (N.O.)
Indicator: 360° LED
Load current: 200 mA max.
Internal voltage drop: < 2.0 V
Current consumption: 10 mA max.
Operating voltage: 10 - 30 VDC
Reverse polarity protection: Yes
Response frequency: 2 kHz
Shielded design: Yes
Sensing range: 4 mm
Temperature range: -25°C to 75°C (-13°F to 167°F)
NEMA rating: 6
IEC rating: IP67
Ratings: UL, CSA, CE

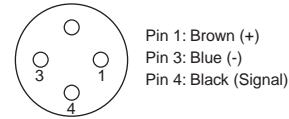

P8S-HISP-017

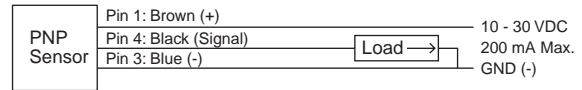

P8S-HISN-017

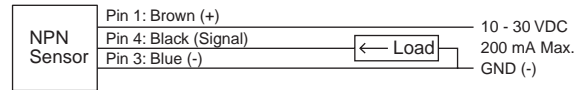

B

Automation Products
 Actuator Products

Grippers

Slide Tables

Rotary Tables

Escapements

Sensors

Fittings

Fittings

Male Connector	Thread (BSPP) / Tube	3mm	4mm (5/32 in)	6mm	8mm (5/16 in)	10mm	12mm
	M3	68LF-3M-M3					
	M5	68LF-3M-M5	68LF-4M-M5	68LF-6M-M5			
	1/8		68LF-4M-2G	68LF-6M-2G	68LF-8M-2G		
	1/4		68LF-4M-4G	68LF-6M-4G	68LF-8M-4G	68LF-10M-4G	68LF-12M-4G
	3/8			68LF-6M-6G	68LF-8M-6G	68LF-10M-6G	68LF-12M-6G
	1/2			68LF-6M-8G	68LF-8M-8G	68LF-10M-8G	68LF-12M-8G

Male Elbow 90° Swivel	Thread (BSPP) / Tube	3mm	4mm (5/32 in)	6mm	8mm (5/16 in)	10mm	12mm
	M3	369PLP-3M-M3	369PLP-4M-M3				
	M5	369PLP-3M-M5	369PLP-4M-M5	369PLP-6M-M5			
	1/8		369PLP-4M-2G	369PLP-6M-2G	369PLP-8M-2G		
	1/4		369PLP-4M-4G	369PLP-6M-4G	369PLP-8M-4G	369PLP-10M-4G	369PLP-12M-4G
	3/8			369PLP-6M-6G	369PLP-8M-6G	369PLP-10M-6G	369PLP-12M-6G
	1/2			369PLP-6M-8G	369PLP-8M-8G	369PLP-10M-8G	369PLP-12M-8G

Flow Control Right Angle	Thread (BSPP) / Tube	3mm	4mm (5/32 in)	6mm	8mm (5/16 in)	10mm	12mm
	M3	FCM731-3M-M3	FCM731-4M-M3				
	M5	FCM731-3M-M5	FCM731-4M-M5	FCM731-6M-M5			
	1/8		FCM731-4M-2G	FCM731-6M-2G	FCM731-8M-2G		
	1/4			FCC731-6M-4G	FCC731-8M-4G	FCC731-10M-4G	
	3/8				FCC731-8M-6G	FCC731-10M-6G	FCC731-12M-6G
	1/2						FCC731-12M-8G

B
 Automation Products
 Actuator Products

Grippers

Slide Tables

Rotary Tables

Escapements

Sensors

Fittings

