

- Angular gripper, 2-finger - economy
- Comprehensive range of bore sizes, 12mm to 32mm
- Magnetic piston standard

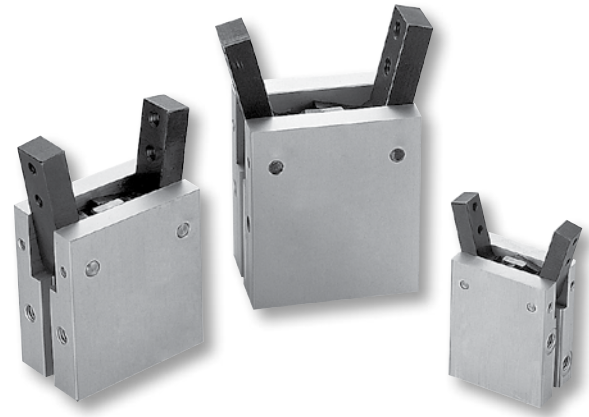

**Operating information**

Operating pressure:	1.5 to 7 bar (21.8 to 102 PSIG)
Temperature range:	-5° to 60° C (23° to 140° F)
Maximum frequency:	180 cycles/min

**Ordering Information: P5GA Angular Gripper Series - Economy**

Function	Bore size (mm)	Ports (BSP)	Rotation	Weight (g)	Part number
Double acting magnetic	12	M3	-10 to 30 degrees	53	<b>P5GA-012MSG030B</b>
Double acting magnetic	16	M5	-10 to 30 degrees	103	<b>P5GA-016MSG030B</b>
Double acting magnetic	20	M5	-10 to 30 degrees	193	<b>P5GA-020MSG030B</b>
Double acting magnetic	25	M5	-10 to 30 degrees	327	<b>P5GA-025MSG030B</b>
Double acting magnetic	32	M5	-10 to 30 degrees	525	<b>P5GA-032MSG030B</b>

Sensor part numbers: Page 53.

Most popular.

**Clamp Force - P5GA-012**

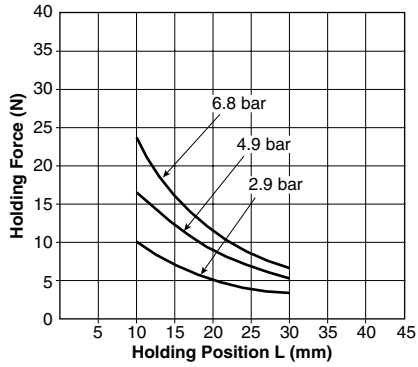

**Clamp Force - P5GA-016**

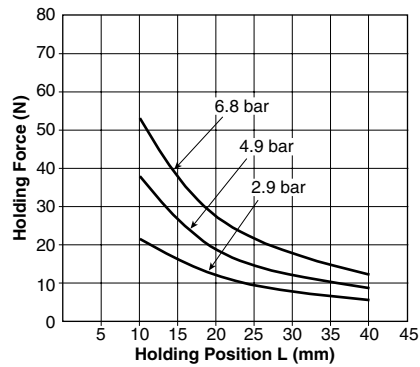

**Clamp Force - P5GA-020**

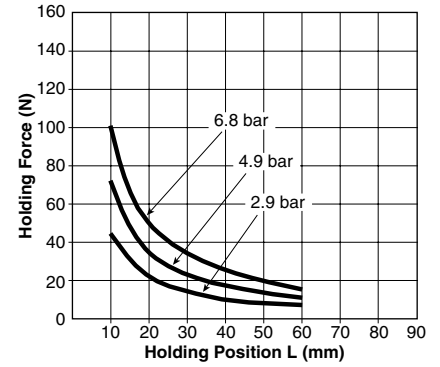

**Clamp Force - P5GA-025**

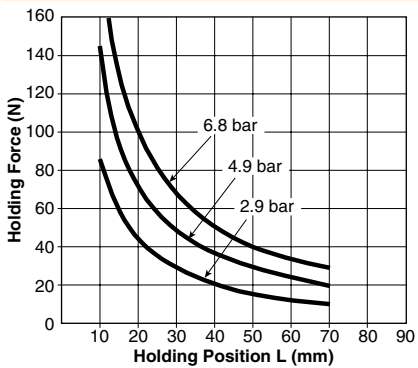

**Clamp Force - P5GA-032**

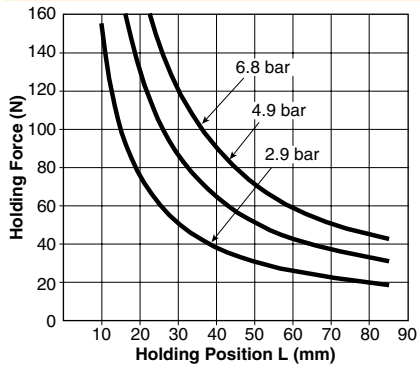

**Dimensions: P5GA Angular Gripper Series - Economy**

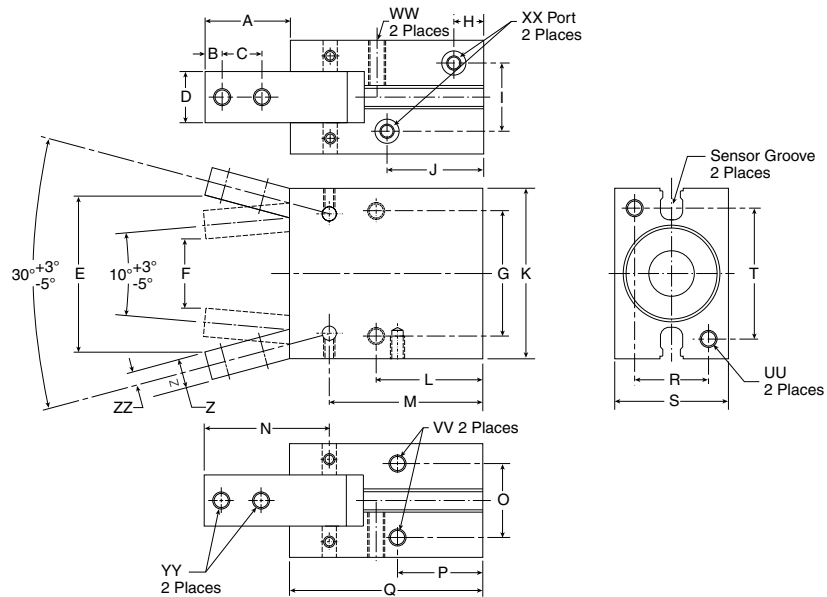

**Tube**

I.D.	A	B	C	D	E	F	G	H	I	J	K	L	M	N	O	P	Q	R	S	T	UU	VV	WW	XX	YY	Z	ZZ
12	15.4	3	6	7	26.3	9	20	7.5	10.2	23.5	28	20	32.9	21.5	10.2	16	39	10	16	22	M3	M3	M3	M3	M3	5	2.5
16	17.5	3	8	9	31.1	14	24	7.5	12	22	34	22.5	35	25	14	18	42.5	14	22	26	M4	M4	M4	M5	M3	6	3
20	22	4	10	12	40.1	18	30	8	13	25	45	25	39.5	32.5	16	19	50	16	26	35	M5	M5	M5	M5	M4	7	3.5
25	26	5	12	14	47.9	21	36	8.5	18	28	52	28.5	45.5	38.5	20	21.5	58	20	32	40	M6	M6	M6	M5	M5	9	4
32	30	6	14	18	55.1	24	44	10.5	24	34	60	37.5	54	44	26	30	68	26	40	46	M6	M6	M6	M5	M6	10	5

Dimensions in millimeters

