

IQAN-XT2

Instruction book

Publ no HY33-8313-IB/UK
Edition 2012-11-06

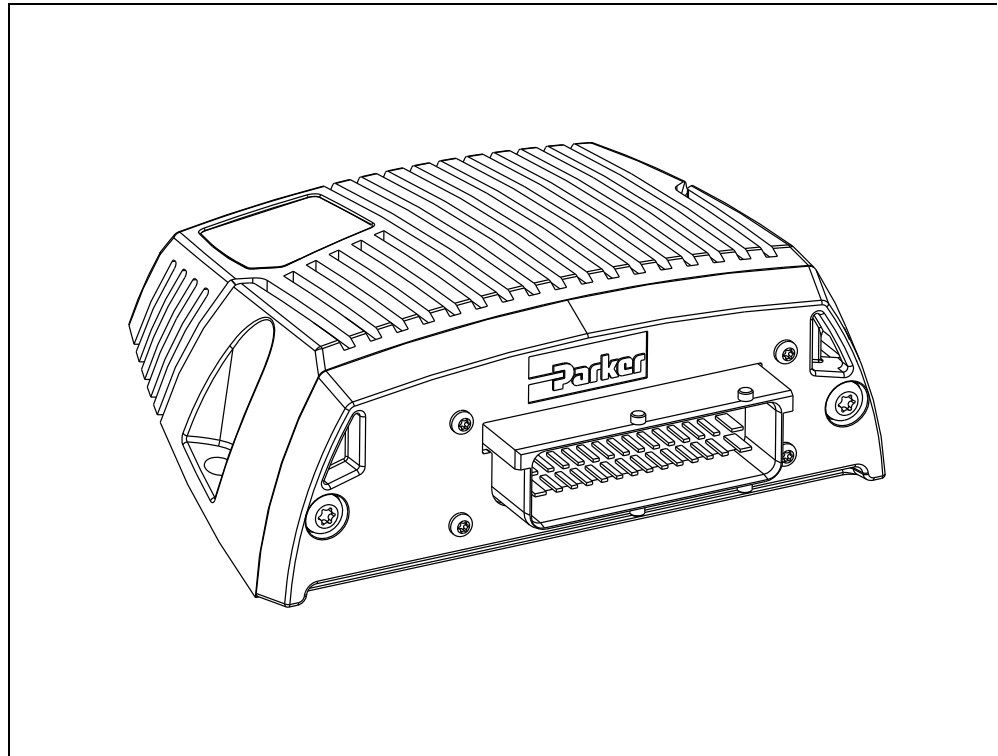

ENGINEERING YOUR SUCCESS.

Contents

1	Introduction	1
	Warnings	1
	Overview of relevant documentation	2
2	Precautions	3
	Read This	3
3	Product description	5
	IQAN-XT2	5
4	Safety	6
	Internal diagnostics	6
	CAN-bus interruption	6
	Current check	6
	Emergency stop	6
5	Mounting	7
	Mounting the module	7
6	Installation	8
	Connector C1	8
	Supply voltage	9
	IQAN-XT2 addressing/terminating	10
	CAN connection	11
	Reference voltage, VREF	11
	Voltage inputs	12
	Frequency inputs	15
	Current outputs	16
	Digital outputs	17
	PWM outputs	19
	E-GAS outputs	20
7	Start-up	21
	Start-up procedures	21
8	System Diagnostics	22
	Appendix A	23
	IQAN-XT2 Technical Overview	23
	Appendix B	27
	Error codes, messages and actions	27
	Appendix C	30
	Dimensioning of the IQAN-XT2 module	30

1 Introduction

These instructions are to be used as a reference tool for the vehicle manufacturer's design, production, and service personnel.

The user of these instructions should have basic knowledge in the handling of electronic equipment.

Warnings

Sections marked with a symbol in the left margin, must be read and understood by everyone using the system, carrying out service work, or making changes to hardware and software.

The different symbols used in this manual are defined below.



WARNING

Sections labeled *WARNING* with a caution symbol in the left margin, indicate that a hazardous situation exists. We use warnings, marked with the warning symbol, in two ways.

- As a strong recommendation about work practices when using the product in the machine (e.g. routines when updating an application). This use is common to the term 'hazardous situation', that a person is exposed to a hazard.
- As a way of pointing out important information for the machine designer that in some way relates to safety. This includes the design of the physical machine, and also the application program being developed for the control system.

Not all document sections that contain information about safety are marked with a warning symbol (there would be warnings everywhere). Failure to comply with the recommendations can cause unintentional, and unexpected behavior of the control system. This can potentially cause death, serious injury or property damage.



NOTICE

Sections labeled *NOTICE* with a notice symbol in the left margin, indicate there is important information about the product. Ignoring this could result in less than optimal performance, or damage to the product.

Contact the manufacturer if there is anything you are not sure about or if you have any questions regarding the product and its handling or maintenance.

The term "manufacturer" refers to Parker Hannifin Corporation.

Overview of relevant documentation

The following publications are relevant for users of this product.

The main documentation contains information that is not found elsewhere.

The additional documentation contains product information in a compact format, for details on the information found in those documents, consult this manual.

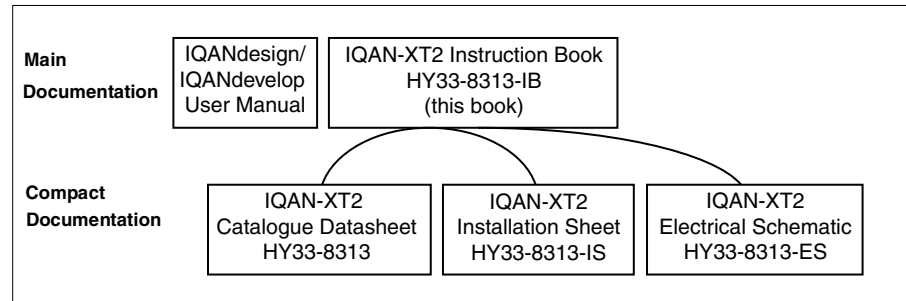

The IQAN-XT2 module documentation system.

2 Precautions

Work on the hydraulics control electronics may only be carried out by trained personnel who are well-acquainted with the control system, the machine and its safety regulations.



WARNING

Make sure that you have sufficient knowledge before designing, modifying or servicing the control system.

Read the relevant sections of this document before conducting any work on the control system.



WARNING

This product is not field repairable.



NOTICE

As much as possible of the welding work on the chassis should be done before the installation of the system. If welding has to be done afterwards, the electrical connections on the system must be disconnected from other equipment. The negative cable must always be disconnected from the battery before disconnecting the positive cable. The ground wire of the welder shall be positioned as close as possible to the place of the welding. The cables on the welding unit shall never be placed near the electrical wires of the control system.

Read This

Design of control system



WARNING

Risk of injury may be introduced by design of control system!

This product is designed to control hydraulic outputs. The control application must be designed using basic safety principles so that unintentional movement is avoided.

The machine must be equipped with an emergency stop that stops all movement. Please refer to section Emergency stop, on page 9.

Before you start

Read this document, as a minimum sections 1-7

Read the IQANdesign software user manual section on 'application safety'.

Start-up, maintenance, and diagnostics

For all personnel carrying out installation, commissioning, maintenance or troubleshooting.



WARNING

Work on the hydraulics control electronics may only be carried out by trained personnel who are well-acquainted with the control system, the machine and its safety regulations.

Before you start,

Read section Start-up, on page 21.

Additional information for service

Mounting and maintenance instruction book.

Additional information for diagnosing the system

Read section System Diagnostics, on page 22, and see Appendix B, on page 27, in this document.

Use the IQANrun/IQANdevelop software user manual as a reference.

3 Product description

IQAN-XT2

The IQAN-XT2 is one out of several expansion modules designed for controlling hydraulic systems in vehicles and machinery, using 12/24 Vdc power supply.

The IQAN-XT2 is able to be used in both IQANdevelop platform and IQANdesign platform systems.

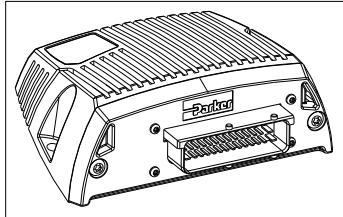

The IQAN-XT2 module.

Input

The IQAN-XT2 module has 10 *voltage inputs* for connecting of 0-5 Vdc signals. VIN-H thru VIN-J can be configured as *frequency inputs* for measuring frequency. *Voltage inputs* and *frequency inputs*, share positions, see below.

(10) Voltage inputs VIN-A, VIN-B, VIN-C, VIN-D.....VIN-J

or

(7) Voltage inputs VIN-A thru VIN-G and (3) Frequency inputs FIN-A thru FIN-C

Output

The IQAN-XT2 module has two (2) double *current outputs* that are regulated for controlling proportional valves. The module also has six (6) *digital outputs* for on/off valves which can be configured as either six (6) individual or three (3) double *PWM outputs* (Pulse Width Modulation) for non-regulated control of proportional valves and devices. Digital and PWM outputs share positions, see below.

(2) double Current outputs

(6) Digital outputs, or (3) double PWM outputs

In order to increase the performance of current outputs when controlling proportional valves, both the *dither frequency* and the *dither amplitude* can be adjusted.

The *digital output channels* also have *soft start* and *peak & hold* features available.

CAN related functions

The master uses the CAN-bus (CAN = Control Area Network) to communicate with the modules. The CAN-bus is used and well proven within the automotive industry.

4 Safety

Internal diagnostics

The module performs a number of self-checks that improve safety. Checks include monitoring of voltage supplies, checksums on memory and a watchdog that monitors software execution. The module is using a real time operating system which supervises software execution.

If a critical error is detected, the module is stopped, with CAN bus and outputs off.

CAN-bus interruption

The IQAN-XT2 communicates with an IQAN master module on the CAN bus. Both the master and the IQAN-XT2 check for any interruptions in the CAN-bus communication. If an error occurs the master will use zero or an application defined error value for the module inputs, and the module outputs will be off.

The error will be indicated both on the master module and with a blink code on the unit; see Appendix B, on page 27

Current check

For the proportional outputs when used in current mode, a current check is performed. If an error is detected, this will be indicated on the master module, and the output will shut off.

The XT2 module can detect open-circuit, short-circuit to +BAT/-BAT or short-circuit to other proportional output and return pins.

Emergency stop



WARNING

Risk of injury! The emergency stop must disconnect the power supply to the module; do not connect the emergency stop as a signal input only.

The emergency stop must be installed so that the risk of reverse feed of the module is avoided, see section Emergency stop, on page 9.

5 Mounting

Mounting the module

The IQAN-XT2 module should be mounted according to the following instructions:

- Locate the module eliminating the risk for the cabling to be folded, crushed or damaged in any way. Ensure the cabling cannot pull, twist or induce sideload on the connector.
- Locate the module so that severe physical impact is avoided, e.g impact from falling objects or the module being used as a step.
- Locate the module so that air can circulate to eliminate excess heat. Ensure that no external heat, e.g. from the engine or heater, is transferred to the module.
- Locate the module to protect it from high pressure washing or similar.
- Locate the module so that the cable connector is facing down .
- Locate the module so that the LEDs are visible.

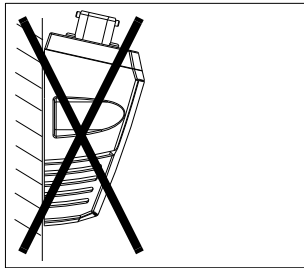

Non approved placing.



NOTICE

The IQAN-XT2 module must not be placed in any marine related or similar continuously damp environment without external protection.

Assembling of the ID-Tag

The ID-Tag will be placed in the connector in order to address/ terminate the module, ref section IQAN-XT2 addressing/terminating, on page 10.

The ID-Tag will be mounted under the connector casing. Bend the ID-Tag's cables toward the opposite side of where the other cables enter the connector.

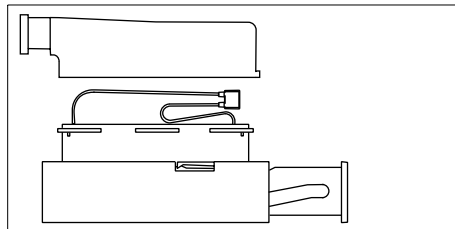

Assembling of the Id-Tag.

6 Installation

Connector C1

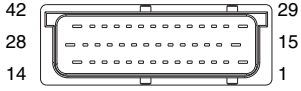
Connector kit	Parker no. 5031063		
Housing	Amp no. 1-963226-1		
Casing	Amp no. 0-965643-1		
Plane sealing, 42 p	in module connector		
Pin types*	Amp no. 963711-2 (MT)	Amp no. 929929-1 (JPT)	
Cables	0,75-1,0 mm ² (MT)	1,5-2,5 mm ² (JPT)	
Seals	Amp no. 963530-1 (MT)	Amp no. 828905-1 (JPT)	
Plugs (empty pos.)	Amp no. 963531-1 (MT)	Amp no. 828922 (JPT)	
IQAN crimping tool references	Blue handle, pos. B use blue extraction tool	Red handle, pos. B use yellow extraction tool	
IQAN tool kit	Parker no. 5031061		

*= The connector contains two types of terminals: MT (Micro Timer) and JPT (Junior Power Timer).

Pos	Signal name	Pos	Signal name	Pos	Signal name
1	ADDR-H	15	-BAT	29	-BAT2
2	DOUT-A	16	CAN-H	30	CAN-L
3	DOUT-B	17	COUT-A	31	COUT-A
4	DOUT-C	18	CRET-A+	32	CRET-A-
5	DOUT-D	19	COUT-B	33	COUT-B
6	DOUT-E	20	CRET-B+	34	CRET-B-
7	DOUT-F	21	VIN-A/EGAS-RET	35	VIN-F
8	EGAS+	22	VIN-B	36	VIN-G
9	EGAS-	23	VIN-C	37	VIN-H/FIN-A
10	+VREF-EGAS	24	VIN-D	38	VIN-I/FIN-B
11	-VREF-EGAS	25	VIN-E	39	VIN-J/FIN-C
12	+VREF	26	CAN2-H	40	CAN2-L
13	-VREF	27	CAN-H	41	CAN-L
14	ADDR-L	28	+BAT (+12 V, +24 V)	42	+BAT2 (+12 V,+24 V)

Unshaded positions are Junior Power Timer pins. Shaded positions are Micro Timer II pins. See above for wire, seal, pin number and crimping tool information. The IQAN tool kit is found in the 'IQAN accessories' datasheet.

Supply voltage

Before any installation of the IQAN system can take place, make sure the ignition lock is turned off and the battery is disconnected.

Emergency stop

Make sure an *Emergency Stop* disconnecting the power supply, is easily accessible at any time. The figure below shows how to connect the emergency stop.

Connecting of Supply Voltage

The supply voltage, should be within the operating interval, see Appendix A, on page 23. Connect the supply voltage to +BAT, position 28 and -BAT, position 15. Protect the module by using a fuse. Requisite fuse level should be 20 A, fast (F).

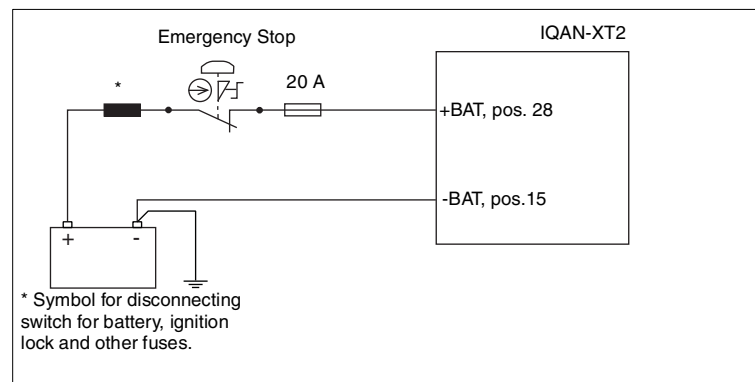

Connecting the emergency stop and voltage supply.



NOTICE

Do not use the chassis as the negative terminal.

Supplying a high current draw system

If the IQAN-XT2 module is used to control several digital outputs simultaneously, it is recommended to source power thru the +BAT2 and -BAT2 positions in addition to the +BAT and -BAT. Requisite fuse level can be max 30 A, fast (F).

EXAMPLE

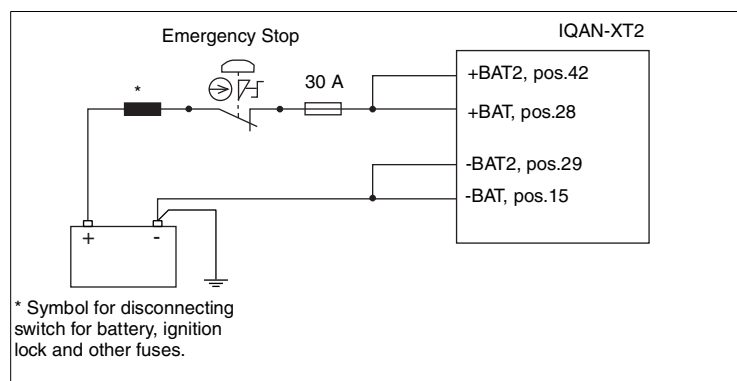

Connecting the emergency stop and voltage supply.

IQAN-XT2 addressing/terminating

Addressing

Each IQAN-XT2 module will have a specific address, enabling the *master module* to communicate with the modules through the CAN-bus. When operating, the system distinguishes between different modules by first verifying the module type and secondly, through the modules having unique addresses.

EXAMPLE

If having an IQAN-XT2 module with address 0, the system will denote this one as IQAN-XT2-A0, The letter "A" refers to CAN-bus A.

The maximum number of similar modules in a system is four or eight depending on the master module, denoted in the first case as addresses 0, 1, 2, 3 respectively. In order to assign any IQAN-XT2 module a unique CAN-address, an *ID-Tag* will have to be connected to the positions ADDR-H and ADDR-L.

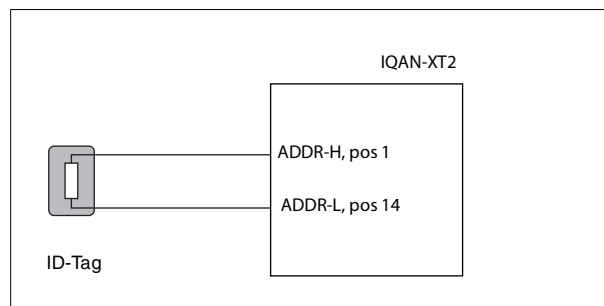

Connecting of Id-Tag in IQAN-XT2 connector housing.

Terminating

To eliminate interference in the communication through the CAN-bus, the CAN-bus must be terminated. Because the master module always is located at the beginning of the bus, the master is provided with an internal termination.

You will only need to terminate the end of the bus.

If an IQAN-XT2 is located at the end of the CAN-bus, then use an ID-tag having a combined address and terminating function. This is denoted with a "T" for terminating, after the appropriate address, such as; 0T, 1T, 2T...

Selecting appropriate Id-Tag

- Check the address number of the module.
- If the module is located at the end of the CAN-bus then select the appropriate *ID-Tag* denoted with a "T".



NOTICE

The CAN-bus must not be terminated using an external regular terminating resistor, due to the fact that terminating is made from within the IQAN-XT2 module in conjunction with each *ID-Tag*.

CAN connection

The module has a CAN interface that can be used to connect to SAE J1939 or similar bus for communication between IQAN-XT2 and other systems.

Connecting to CAN interface

The interface is connected from the engine's SAE J1939 interface to the CAN2_H and the CAN2_L.

EXAMPLE

Connect the SAE J1939 CAN_H and CAN_L pins to the CAN2_H, position 26 and the CAN2_L, position 40 on the IQAN-XT2.

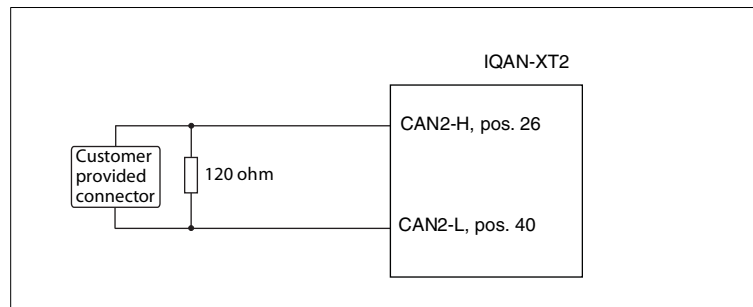

Connecting a SAE J1939 interface to the XT2 CAN hub.

Reference voltage, VREF

The IQAN-XT2 module is internally equipped with two voltage regulators to generate the reference voltages *VREF* and *VREF_EGAS*. The standard reference voltage will feed different kinds of sensors. The EGAS reference voltage is intended to supply an electronic throttle device.

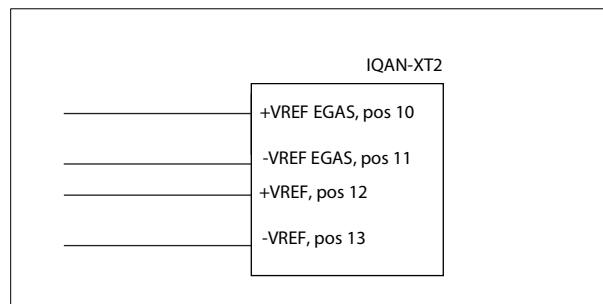

VREF positions.



NOTICE

Maximum load for the *VREF* and *VREF_EGAS* is different according to 12/24 Vdc power supply, see Appendix A, on page 23.

Voltage inputs

Connecting sensors to the voltage inputs

The sensor signal range must be 0-5 Vdc. To detect signal errors such as short circuits or interruptions the active signal range be within 0.5-4.5 Vdc.

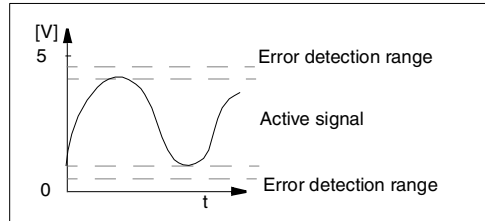

Active signal range.

The current consumption related to the voltage input is negligible.

The positive terminal of the sensor is connected to the +VREF position and the corresponding negative terminal to the -VREF position. The sensor signal is connected to appropriate VIN position.

EXAMPLE

Connect the positive and negative terminals of the position sensor to +VREF, position 12, and -VREF, position 13, respectively. Then connect the sensor signal to VIN-A, position 21.

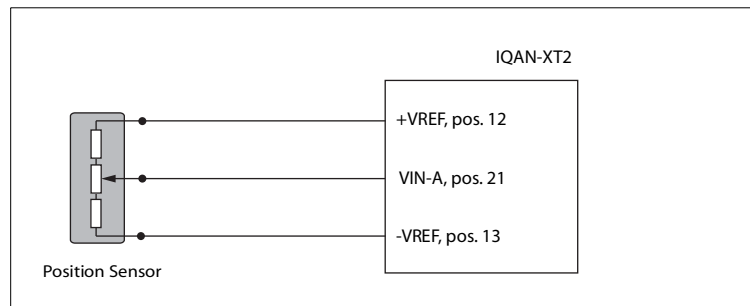

Connecting VREF and sensor signal VIN-A.



NOTICE

The negative terminal of the sensor must not be connected to the chassis.
Maximum load for VREF position: see Appendix A, on page 23.

Connecting other 3 wire sensors

The same type of connection shown for potentiometers is used for other 3 wire sensors supplied with power from the regulated 5VDC supply, VREF. This includes active temperature sensor IQAN-ST, pressure sensor IQAN-SP and Hall-effect levers IQAN-LST or IQAN-LSL.

Connecting a 2 wire temperature sensor to voltage in

When you connect a PTC (positive temperature coefficient) temperature sensor you may need to use a pull up resistor on the input signal. Please check the technical data for your specific temperature sensor.

EXAMPLE

Connect the negative terminal of the temperature sensor to -VREF, position 13, and the signal to VIN-A, position 21. The pull up resistor will be connected between VIN-A, position 21 and +VREF, position 12.

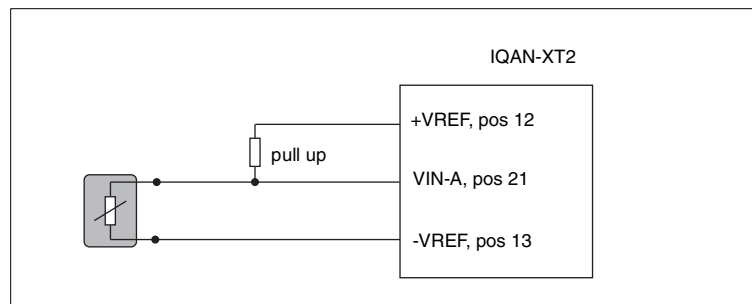

Connecting -VREF and temperature sensor signal VIN-A.

The pull up resistor value for a $R_{25}=2000\Omega$, PTC sensor is 4.7 K Ω

Connecting switches to the voltage inputs

Switches could be connected to the voltage inputs, to create a digital on/off signal. The switches should be connected to +VREF and VIN respectively for 5V signal. The current consumption for the voltage input is negligible.

EXAMPLE

Connect the positive and negative terminals of the switch to +VREF, position 12, and VIN-A, position 21, respectively.

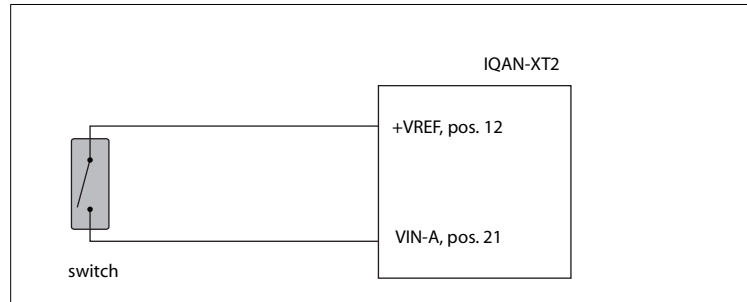

Connecting a switch to VIN-A and VREF.



NOTICE

Maximum load for VREF position, see Appendix A, on page 23.

It is recommended to connect system voltage +BAT to the voltage input through a switch in order to reserve 5Vdc VREF for sensors and potentiometers.

EXAMPLE

Connect the positive and negative terminals of the switch to +BAT and VIN-A, position 21, respectively.

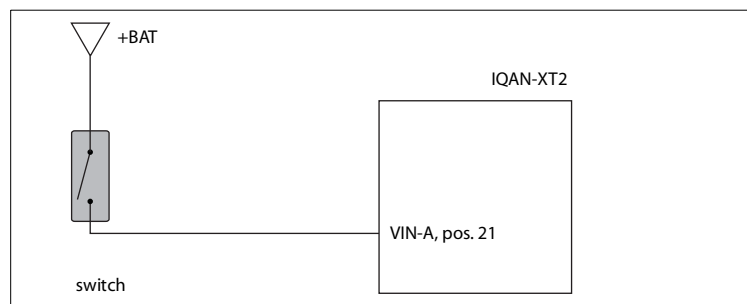

Connecting a switch to VIN-A and +BAT.

Frequency inputs

Connecting sensors to the frequency inputs

For the frequency ranges and trigger levels, see Appendix A, on page 23.

Simple frequency sensor

The positive terminal of the frequency sensor is connected to the +VREF and the negative terminal to the -VREF respectively. The sensor signal is connected to the FIN position.

If the current consumption for the sensor exceeds the maximum load for the VREF, the sensor could be connected to the BAT positions.

EXAMPLE

Connect the positive and negative terminals of the frequency sensor to +VREF, position 12, and -VREF, position 13, respectively. Then connect the sensor signal to FIN-A, position 37.

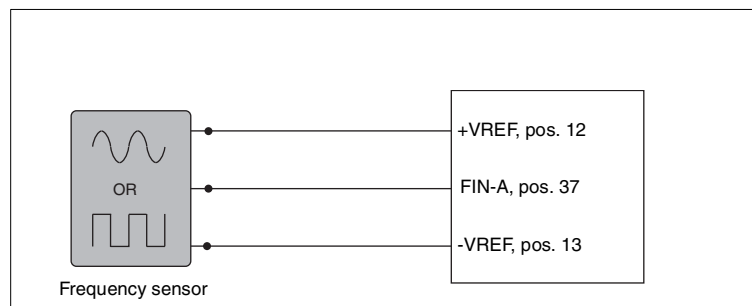

Connecting of frequency sensor.



NOTICE

The negative terminal of the sensor must not be connected to the chassis. Maximum load for each VREF position, see Appendix A, on page 23.

Current outputs

The current output signals control proportional valves and devices. For the current range see Appendix A, on page 23.

Dither frequency and amplitude

To obtain the best performance from proportional valves the module produces a direct current (DC) with a dither. The *dither frequency* and the *dither amplitude* can be adjusted in IQANdevelop. Depending of what kind of valve is to be used, a certain recommended dither frequency/amplitude set-up can be supplied by Parker Hannifin Corporation, in order to obtain an optimized valve hysteresis. Both frequency and amplitudes will then be set in IQANdevelop.

Connecting loads to current outputs

Connecting a load, e.g. one proportional valve, to the current output is done by using the COUT/CRET paired positions.

EXAMPLE

Positive direction:

Connect the proportional valve to the COUT-A, position 17 and the CRET-A+, position 18 respectively.

Negative direction:

Connect the proportional valve to the COUT-A, position 31 and the CRET-A- , position 32 respectively.

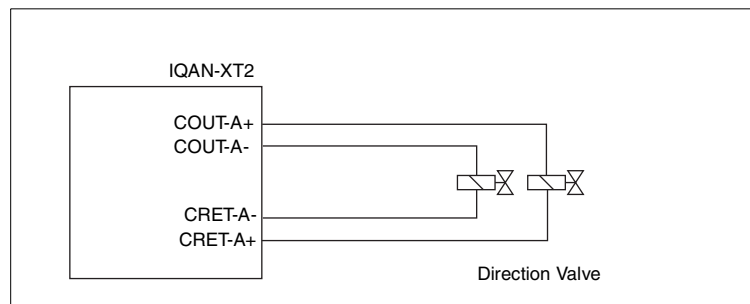

Connecting a load to the current output.

Digital outputs

The digital outputs control relays and on/off valves.

For the maximum load per output see Appendix A, on page 23.

Soft start

Soft start is used whenever start up is required to be smoother than the normal procedure offers. A desired ramp function secures the smoother start up according to the figure below. The ramp function is set up from within IQANdevelop.

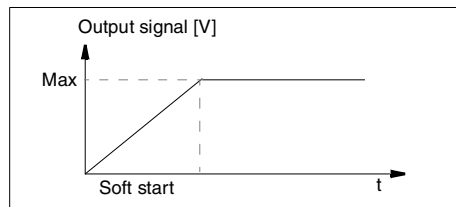

The Soft start function.

Peak and Hold

The *Peak and Hold* feature makes it possible to decrease the voltage to the valve solenoid. Shortly after a valve has been activated, the voltage can be decreased to a lower level, sufficient to maintain the position of the valve, but also reducing the heat generated in the valve (due to this lower voltage). The reducing of heat, is the primary reason for selecting the *Peak and Hold* feature. Both the peak time and the hold value are set up from within IQANdevelop.

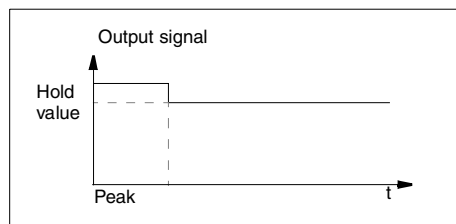

The Peak and Hold valve voltage graph.

Connecting loads to digital outputs

Connecting of loads to the digital outputs such as on/off valves is done by using the DOUT positions and chassis as ground.

Protection against voltage transients

A clamping diode must be placed between the digital output and ground, as close to the load as possible. This protects the output against high voltage transients.

For example: Use the diode 1N5408 (3A/1000V).

Depending on the load, other clamping diodes might be used instead.

EXAMPLE

Connect the on/off valve to the digital output using the DOUT-A, position 2, and the chassis as ground.

A clamping diode must be placed as close to the load as possible, see figure below.

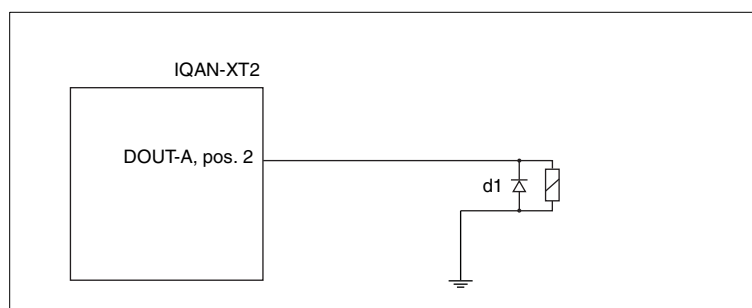

Connecting a load to the digital output.

If the load is controlled in parallel with another system, the digital output shall be protected with a diode.

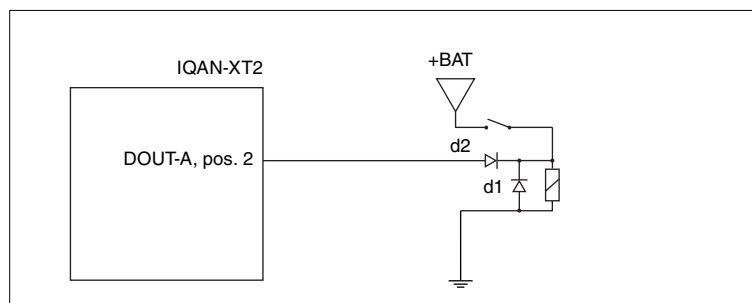

Digital output protected with a diode.

PWM outputs

The PWM output (Pulse Width Modulation) control pilot valves. Maximum load should not exceed 3,0 A per output.

Connecting loads to PWM outputs

The load is connected between the PWMOUT and the chassis ground. For the maximum load per output, see Appendix A, on page 23.

Protection against voltage transients

A clamping diode must be placed between the output and ground, as close to the load as possible, to protect the output against high voltages transients.

For example: Use the diode 1N5408 (3A/1000V).

Depending on the load, other clamping diodes might be used instead

EXAMPLE

Positive direction:

Connect the load between the PWMOUT-A, position 2, and the chassis as ground.

Negative direction:

Connect the load between the PWMOUT-B, position 3, and the chassis as ground.

A clamping diode will be placed as close to the pilot valve as possible.

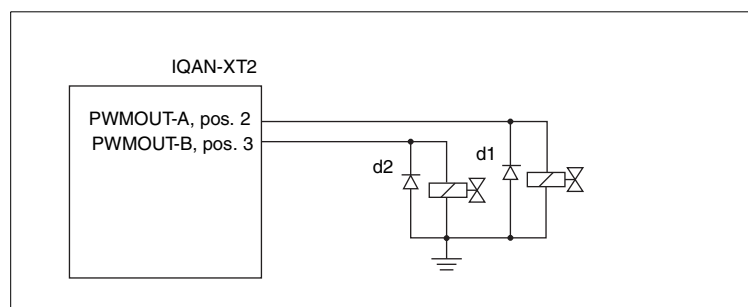

Connecting a load to the PWM output.

E-GAS outputs

The E-GAS outputs (Electronic Gas) control a motor-type throttle device. Maximum load should not exceed 2,5 A.

Connecting load to E-GAS output

The load is connected between the +EGAS, -EGAS and the EGAS_RET (feedback signal dedicated to VIN-A).

For the maximum load per output, see Appendix A, on page 23.

EXAMPLE

Positive and negative direction:

Connect the load between the +EGAS, position 8, and the -EGAS, position 9.

EGAS Position feedback:

Connect the EGAS_RET to VIN-A, position 21, the +VREF_EGAS, position 10 and the -VREF_EGAS, position 11.

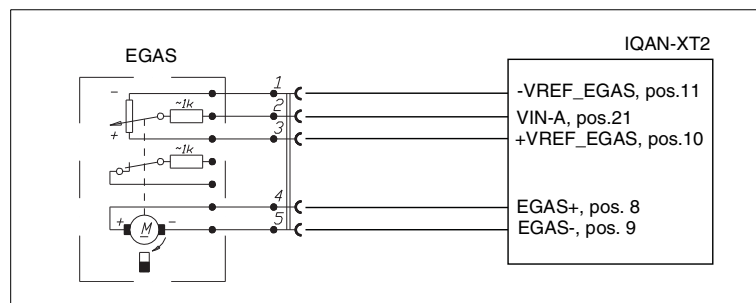

Connecting a load to the EGAS outputs.



NOTICE

The working area of the EGAS actuator should be 10%-90% of its travel. The EGAS actuator must be aligned parallel to the diesel engine injector lever.

Do not exceed maximum torque of the EGAS actuator, see the EGAS manufacturer's datasheet for torque specification.

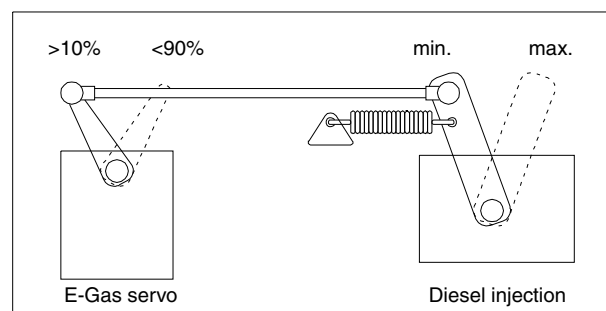

The EGAS mechanical requirements.

7 Start-up

Start-up procedures

This chapter contains instructions for action to be taken in connection with the initial start.



WARNING

Risk of injury!

If the control system is not fitted properly, the machine could move uncontrollably. The machine's engine shall not be started before the control system is completely fitted and its signals are verified.

Starting the control system

Start the control system as follows:

- Prior to start, all modules and cables are to be fitted correctly.
- Check fuses, i.e. make sure that the supply voltage to the modules is equipped with the correct fuse.
- Make sure that connections for supply voltage and return lines are correct in the cable's conductor joint.
- Make sure an emergency stop is installed.
The emergency stop should disconnect the supply voltage to all modules. Alternatively, the emergency stop may also shut off the diesel engine or a dump valve, and with that, depressurize the hydraulic system.

Prepare for system start



WARNING

Make sure no one is in dangerous proximity to the vehicle to avoid injuries when it starts.

Prepare for the initial system start as follows:

- The engine for the hydraulic system's pump shall be in off position.
- Make sure that all connectors are properly connected.
- Turn on the control system.
- Make sure that voltage is being supplied to all modules; the power/status diode shall be illuminated on all modules. Also, make sure that the master is in contact with all modules by reading the master's display.
- Make sure the emergency stop is functioning properly.

Start the system

Start the system as follows:

- Start the engine for the hydraulic system's pump, assuming that the above mentioned inspections have been carried out and shown correct values.
- Calibrate and adjust input and output signals according to the instructions related to the master menu system and check each and every output function carefully.

8 System Diagnostics

The yellow blinking LED on the top of the module indicates normal status. If there is an error detected, the master will present a message on the display. The IQAN-XT2 module also indicates *error status* through the red blinking LED as shown below. This gives an immediate diagnosis as to the nature of the error that has occurred.

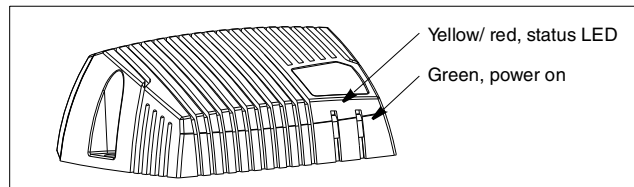

The location of the LED indicators on the IQAN-XT2 module.

The green LED indicates power on. The yellow/red LED, will be blinking red when an error has been detected. To get further information about the error messages, see Appendix B, on page 27

A small recommendation...

You can use the internal diagnostics in the IQAN master display to get more information about the IQAN-XT2 module. The following values are measured:

-
- Internal temperature [°C]
 - Power supply [V]
 - Reference voltage [V]
 - Reference voltage-egas [V]
-

Appendix A

IQAN-XT2 Technical Overview

Absolute Maximum Ratings^a

Parameter	Limit values			Unit	Remark
	min.	typ.	max.		
Ambient temperature, T_A	- 40		+90	°C	
Storage temperature	- 40		+100		
Maximum voltage supply on +BAT			34	V	Reverse polarity protected with 20A fuse.
Voltage on any pin with respect to -BAT			34	V	
Maximum current into -VREF			2	A	
Maximum current sourced by all outputs			20	A	

a. The “Absolute Maximum Ratings” table lists the maximum limits to which the device can be subjected without damage. **This doesn't imply that the device will function at these extreme conditions**, only that, when these conditions are removed and the device operated within the “Recommended Operating Conditions”, it will still be functional and its useful life won't have been shortened.

Environmental ratings

Parameter	Remark
EMI ISO 14982:1998, Radiated emission EN 55025:2003, Conducted emission ISO 11452-2:1995, Radiated Susceptibility ISO 11452-4:2001, Conducted Susceptibility ISO 7637-2:2004, Conducted transient susceptibility on power ISO 7637-3:1995, Conducted transient susceptibility on signal EN 61000-4-8:1993	30-1000 MHz 0.15-108 MHz, class 1 20-1000 MHz, 100V/m 1-200 MHz, 150mA 1,2a,2b,3a,3b,4, 5 80V 100A/m
ESD ISO 10605:2001, ESD	15KV, air, 8 KV contact 4 KV handling
Mechanical environment IEC 60068-2-64:1993 Fh, Random vibration IEC 60068-2-29:1987 Eb, Bump	0.1 g ² /Hz, 15- 250 Hz, 30 hours 40g, 6 ms, 1000 in each direction
Climate environment IEC 60529:2001, Enclosure protection DIN 40050 Part 9:1993, Enclosure protection IEC 60068-2-30:1985 Db, Damp heat cyclic IEC 60068-2-78:2001, Damp heat, steady state IEC 60068-2-14:1984 Nb, Change of temperature	IP66: 100 l/min, 3min IP6K9K: 1000kPa, +80°C, 30sec 55°C, 6 cycles 40°C, 93% RH, 21 days -40°C to 70°C, 100 cycles
Chemical environment IEC 68-2-52:1996 Kb, salt mist	3 days

Recommended Operating Conditions^a

Parameter	Limit values			Unit	Remark
	min.	typ.	max.		
Ambient temperature, T_A	-40		+70	°C	
Voltage supply, V_{BAT}	11		32	V	
Total load on COUT/PWMOUT/DOUT			20	A	

a. Recommended operating conditions are given for maximum and minimum conditions where normal performance is still available from the device. Once the normal operating conditions are exceeded, the performance of the device may suffer.

System

$T_A = +25$ °C (unless otherwise specified)

Parameter	Limit values			Unit	Remark
	min.	typ.	max.		
Start-up delay		TBD		ms	Power to activated output
Dither frequency, DF	25		150	Hz	
Sample rate local I/O.		20		Hz	Dependent of the CAN sample time, exception FIN channels.
CAN message response time		TBD		ms	
Output voltage on VREF	4.9	5.0	5.1	V	load < 40mA
Maximum load current on VREF $V_{BAT} = 11V$ to $32V$			50	mA	$V_{drop} < TBDmV$ (0.5%)
Current supply $V_{BAT} = 14V$ $V_{BAT} = 28V$		140 160		mA	outputs = off no load on VREF

I/O

$T_A = +25$ °C (unless otherwise specified)

Parameter	Limit values			Unit	Remark
	min.	typ.	max.		
VIN (Voltage input)					
Signal range low		0	0.05	V	
Signal range high	4.9	5.0	5.1	V	
Input resistance		62		kΩ	
Signal resolution		5		mV	
Total unadjusted error	-35 -100		35 100	mV	VREF as source <40mA External source
DIN (On/off input)^a					
Input signal low			0.8	V	
Input signal high	4.0			V	
input hysteresis		1.0		V	DIN-A -DIN-J
Input resistance		62		kΩ	

I/O

$T_A = +25\text{ °C}$ (unless otherwise specified)

Parameter	Limit values			Unit	Remark
	min.	typ.	max.		
FIN (Frequency input)					
Input low			1.8	V	
Input high	4.0			V	
Input resistance		62		kΩ	
Input frequency low	1			Hz	
Input frequency high			10.000	Hz	
Step response time		1000		ms	
Zero detection time (Speed mode, start or stop <20 Hz)		250		ms	
Frequency resolution < 1kHz < 5kHz < 10kHz		1 10 40		Hz	$\frac{f^2}{2,5 \cdot 10^6}$
COUT (closed-loop mode)					
Signal range	60		1800	mA	
Load	3.5			W	
Voltage drop ($V_{BAT} - V_{COUT}$) load $I_L = 0.5A$ load $I_L = 2A$		0.2 0.8		V	
Off-State output current:			TBD	mA	
Relative accuracy ^b			±30	mA	PVC25-12V PVC25-24V
Deviation from Mean ^c			TBD	mA	PVC25-12V PVC25-24V
Temperature error			TBD	mA	$T_A = -40\text{°C}$ to 70°C PVC25-12V PVC25-24V
Power supply rejection $V_{BAT} = 11... 18V$ $V_{BAT} = 24... 32V$		1 1		mA	$R_L = 6\ \Omega - 25\ \Omega$
Load regulation $V_{BAT} = 14V, R_L = 4... 9\ \Omega$ $V_{BAT} = 28V, R_L = 22... 34\ \Omega$		1 3		mA	Load=1000mA Load=500mA
Dither frequency, DF	25		150	Hz	
Dither amplitude	0		500	mA	
Resolution		0.7		mA	

I/O

$T_A = +25\text{ °C}$ (unless otherwise specified)

Parameter	Limit values			Unit	Remark
	min.	typ.	max.		
DOUT (on/off output)					
Load current each channel active (A,B,C,D,E,F)			3	A	
Load current one channel in each group (A or B, C or D, E or F)			4	A	The DOUT's are divided into three groups.
Voltage drop ($V_{BAT} - V_{DOUT}$) load $I_L = 0.5A$ load $I_L = 2A$		0.2 0.8		V	
Off-State output current:			TBD	mA	
Max load inductance:			200 1000	mH	@ 2A @ 1A
Short Circuit current limit		6		A	
PWMOUT (open-loop)					
Load current each channel active (A,B,C,D,E,F)			3	A	
Load current one channel in each group (A or B, C or D, E or F)			4	A	The PWMOUT's are divided into three groups.
Signal range	TBD		TBD	% MR	
Voltage drop ($V_{BAT} - V_{PWMOUT}$) load $I_L = 0.5A$ load $I_L = 2A$		0.2 0.8		V	
Off-State output current:			TBD	mA	
Short Circuit current limit		6		A	
Dither frequency, DF	25		2000	Hz	
Resolution		TBD		% MR	
EGAS					
Load current			3	A	
Min load		TBD		W	Open load error
Short Circuit current limit		8		A	$T_A = 25\text{ °C}$
PWM frequency	500		20000	Hz	

- a. Dependent on the master unit. Not implemented in the IQAN-XT2 unit.
- b. Deviation of the output current at any command from its theoretical value (command value).
- c. Deviation between any value and mean value with same command and load.

Appendix B

Error codes, messages and actions

If one of the following errors are detected, a message will be presented on the display together with an error code on the module. In some cases, the module will turn off or at least shut down the outputs, to increase safety.



WARNING

Don't use the machine if an error message or error code is activated.

The following sections will present what measures to take for different error situations put into appropriate context.

LED indicator showing different IQAN-XT2 modes

Status		Blink (yellow light)
Normal (no errors)		
Error code	Error	Blink (red light)
1	I/O and voltage errors	
2	High temperature	
3	CAN error	
4	Hardware error	
5	Address error	
6	Software error	

LOW/ HIGH SUPPLY VOLTAGE

Situation	Error code	Action IQAN-XT2	Comment
+BAT < 8,5 V	Error 1	-	Check voltage supply
+BAT > 34 V	Error 1	-	Check voltage supply

VREF ERROR

Situation	Error code	Action IQAN-XT2	Comment
VREF < 4,9 V	Error 1	-	Check voltage
VREF > 5,1 V	Error 1	-	Check voltage
VREF_EGAS < 4,9 V	Error 1	-	Check voltage
VREF_EGAS > 5,1 V	Error 1	-	Check voltage

MODULE IS OFFLINE

Situation	Error code	Action IQAN-XT2	Comment
CAN-bus off	Error 3	All outputs shut off.	Check CAN-bus
ADDR-H < 4,9 V	Error 5	-	Check voltage ADDR-H
ADDR-H > 5,1 V	Error 5	-	Check voltage ADDR-H
ADDR-L < 0,5 V	Error 5	During start up: The module turns off.	Check voltage ADDR-L
ADDR-L > 4,5 V	Error 5	During start up: The module turns off.	Check voltage ADDR-L
Software error	Error 6	The module turns off.	Contact supplier.

HIGH TEMPERATURE

Situation	Error code	Action IQAN-XT2	Comment
Internal temperature > max temp	Error 2	-	Check ambient temperature
Internal temperature sensor error	Error 4	-	Contact supplier

ERROR: PARAMETER

Situation	Error code	Action IQAN-XT2	Comment
Parameter error	Error 6	No calibration of signals.	Contact supplier

ERROR: OUTPUT HIGH

Situation	Error code	Action IQAN-XT2	Comment
COUT: Current return low	Error 1	Active output shuts off.	Check load
COUT: Current return high	Error 1	In current check activated: Active output shuts off.	Check load
DOUT: Overload	Error 1	Active output shuts off.	Check load
COUT/DOUT: Internal driver failure	Error 4	Active output shuts off.	Contact supplier
EGAS: Overload	Error 1	Active output shuts off.	Check load

Appendix C

Dimensioning of the IQAN-XT2 module

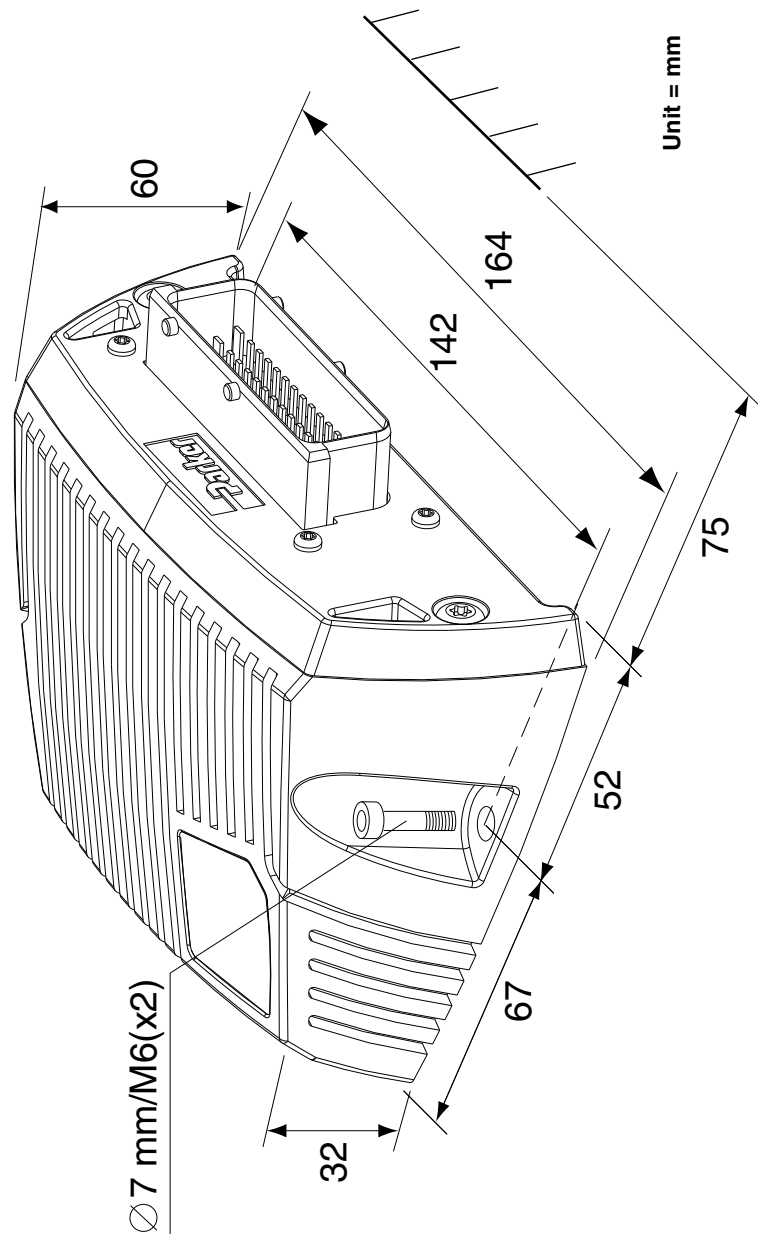

For latest information visit our website www.iqan.com

Information in this instructionbook is subject to change without notice

Publ no HY33-8313-IB/UK
Edition 2012-11-06

Parker Hannifin
Electronic Controls Division
SE-435 35 Mölnlycke
Sweden
Tel +46 31 750 44 00
Fax +46 31 750 44 21
www.parker.com

Parker Hannifin
Electronic Controls Division
1651 N. Main Street
Morton, IL 61550
USA
Tel +1 309 266 2200
Fax +1 309 266 6674

