

7 Displacements	(8.6 to 22.2 in ³ /rev)	
7 Schluckvolumen	140 . . . 364 cm ³ /rev	
7 Cylindrée		
7 Desplazamientos		
	Cont.	Int.
Maximum Pressure	(2750 psid)	(3500 psid)
Eingangsdruck	. . . 190 bar	. . . 241 bar
Pression entrée		
Presion Maxima		
Maximum Oil Flow	(25 gpm)	
Schluckstrom	. . . 95 lpm	
Débit d'huile		
Caudal Maximo de Aceite		
Maximum Speed	(484 rpm)	
Drehzahl	484 rpm	
Vitesse de rotation		
Velocidad Maxima		
	Cont.	Int.
Maximum Torque	(8,650 lb in)	(10,300 lb in)
MaxDrehmoment	977 Nm	1164 Nm
Couple		
Torque Maximo		

Exceptional Power Density and Durability

The heart of the new compact Torqmotor™ is the strongest drive train in its class. Coupled with this extra heavy-duty drive train are the high efficiencies and low speed performance for which the Parker Torqmotor™ is known. As with all Torqmotors™, high speed valving and full flow drive train lubrication are standard. Case drains are not required. Roller vanes and a sealed commutator maintain high efficiencies and provide smooth low speed performance.

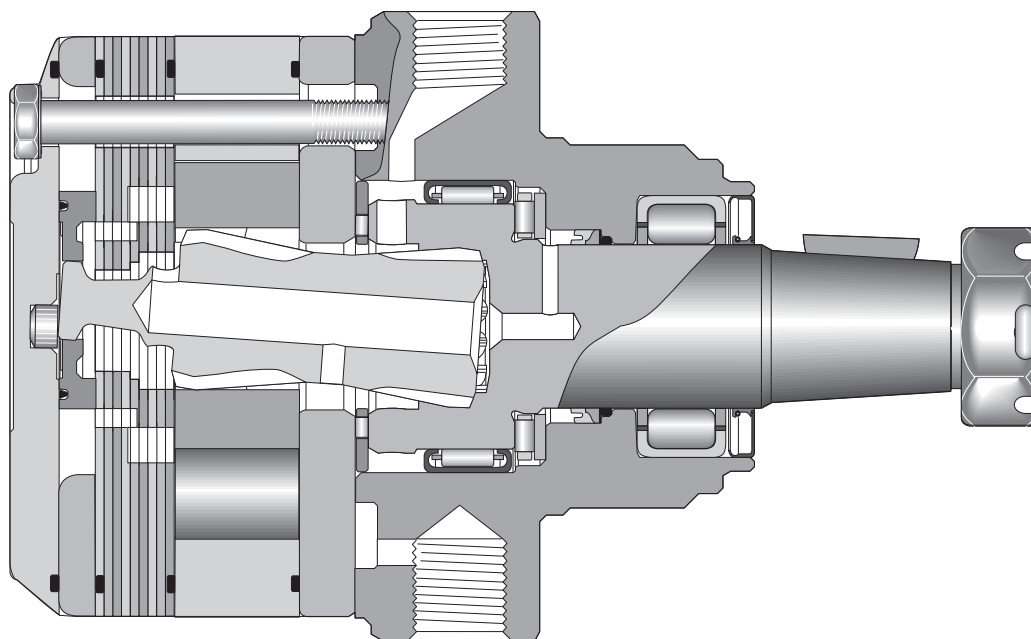

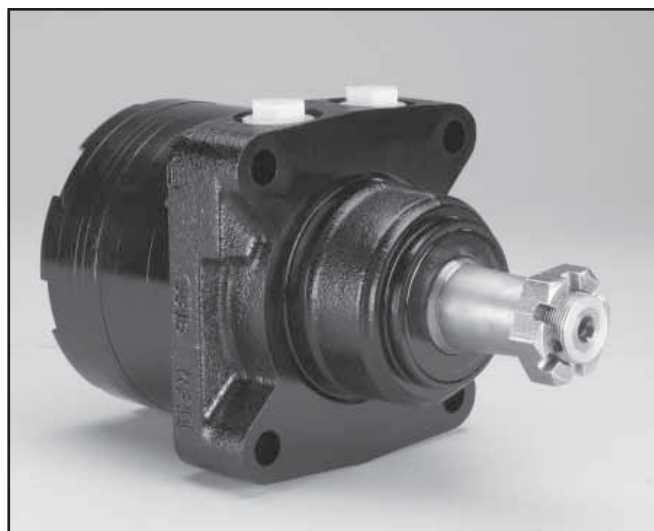
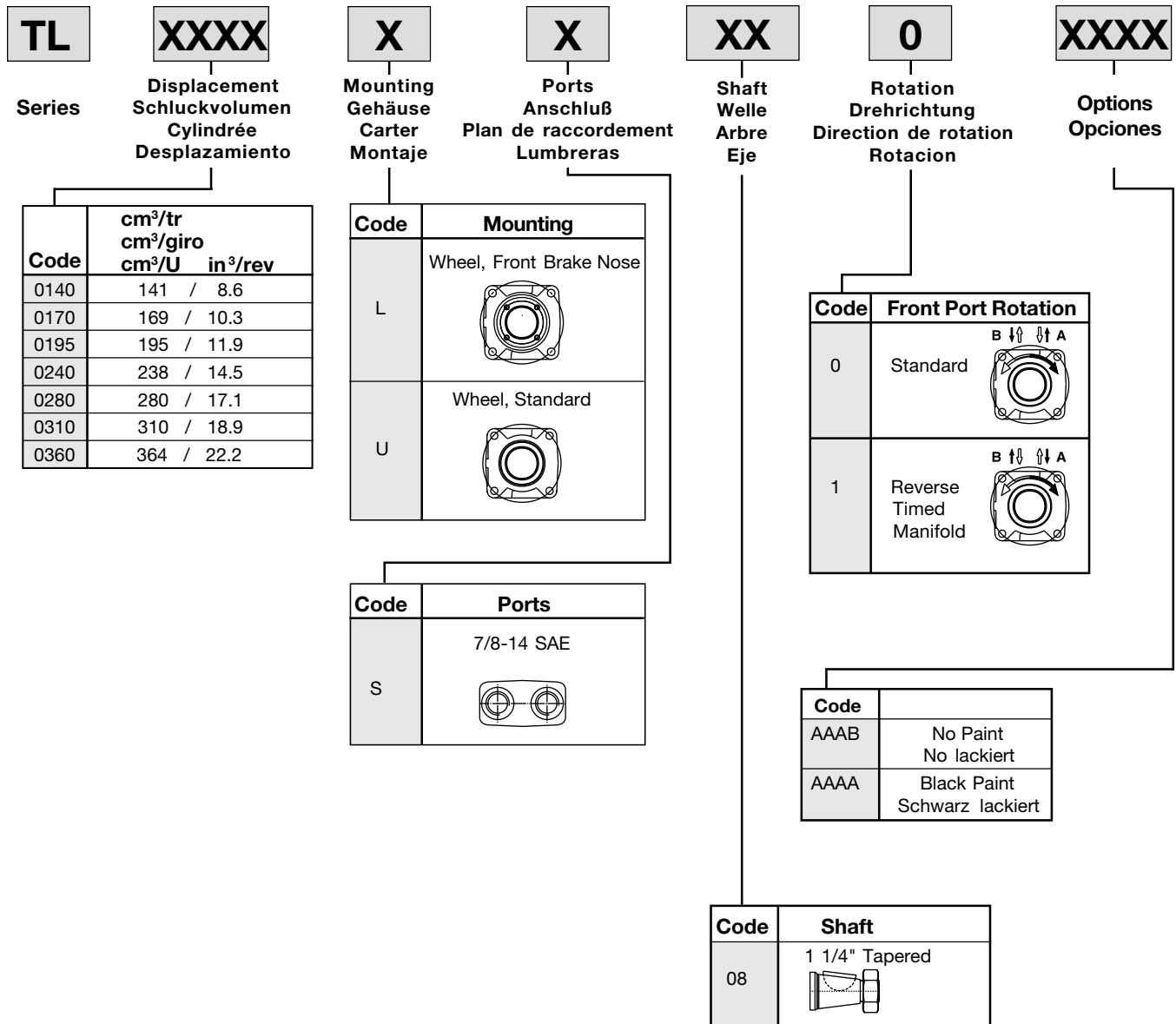

For other available options, see pages 261–262.

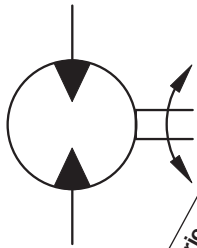

Geometric displacement
Geom. Schluckvolumen
Cylindrée
Cilindrata
Max. speed @ Max. intermittent flow
Max. Drehzahl Intermittierender Betrieb:
Vitesse de rotation maxi
Velocidad maxima a caudal intermitente maximo
Max. oil flow
Max. Schluckstrom
Débit d'huile maxi
Portata max
Max. differential pressure
Max. Druckgefälle
Chute de pression maxi
Presion diferencial maxima
Max. supply pressure
Max. Eingangsdruck
Presion maxi entrée
Presion maxima de alimentacion
Max. torque
Max. Drehmoment
Couple maxi
Torque Maximo
Max. Performance
Max. Leistungabgabe
Puissance de sortie maxi
Potenza meccanica max
Min. starting torque
Min. Anlaufmoment
Couple min. fourni au dé manrage
Torque minimo de arranque

Motor Series TL	cm ³ /rev in ³ /rev	rev/min	cont / int l/min g/min		cont / int bar psid		max bar psig	cont / int Nm lb-in		max KW HP	cont / int Nm lb-in	
TL0140	140 8.6	613	68 18	95 25	190 2750	241 3500	300 4350	364 3226	463 4095	30 40	294 2606	365 3234
TL0170	169 10.3	512	68 18	95 25	190 2750	241 3500	300 4350	449 3970	570 5042	31 41	354 3137	445 3943
TL 0195	195 11.9	484	68 18	95 25	190 2750	241 3500	300 4350	511 4520	648 5739	34 46	414 3666	526 4654
TL 0240	238 14.5	399	68 18	95 25	190 2750	241 3500	300 4350	620 5485	790 6990	34 46	536 4740	679 6011
TL 0280	280 17.1	335	68 18	95 25	190 2750	241 3500	300 4350	730 6460	929 8218	34 45	619 5479	787 6967
TL 0310	310 18.9	310	68 18	95 25	190 2750	241 3500	300 4350	847 7499	1079 9548	36 48	713 6309	907 8029
TL 0360	364 22.2	255	68 18	95 25	172 2500	224 3250	300 4350	890 7874	1163 10293	31 42	778 6882	1002 8867

Performance data based on testing using 10W40 oil with a viscosity of 200 SUS at 54° C (130° F). Performance data is typical. Actual data may vary slightly from one production motor to another.

Les donnees sur les performances sont basees sur des tests utilisant de l'huile 10W40 d'une viscosite de 200 SUS a 54°C (130°F). Ces donnees correspondent a des situations typiques. Les donnees reelles peuvent varier legerement d'un moteur de production a l'autre.

Leistungsdaten sind gemessen mit SAE 10W40 bei einer Viskosität von 43,1 Cst bei 54°C. Geringfügige Abweichungen von den Katalogdaten sind möglich.

Datos tecnicos obtenidos con aceite 10W40 de 200 SUS de viscosidad a 54°C (130°F). Los datos proporcionados son valores tipicos. Los valores exactos reales podrian tener una pequena variacion entre distintos motores.

Intermittent operation rating applies to 10% of every minute.

Intermittierende Werte maximal 10% von jeder Betriebsminute.

Fonctionnement interm. 10% max. de chaque minute d'utilisation.

Capacidad de funcionamiento intermitente valida para 10% por cada minuto.

Peak operation rating applies to 1% max of every minute.

TL 0140

8.6 cu in / rev

	PRESSURE (PSID)							
	500	1000	1500	2000	2500	2750	3000	3500
.5	364 12	955 11	1531 10	2115 9	2719 7	3016 6	3288 5	3803 2
1	395 25	1014 24	1599 23	2174 21	2761 19	3056 17	3352 16	3871 13
2	408 51	1011 49	1634 47	2229 45	2828 42	3127 40	3421 38	3943 35
3	411 77	1029 74	1659 72	2257 69	2856 65	3191 63	3459 62	4006 57
4	414 103	1040 99	1675 96	2286 93	2900 89	3226 86	3509 83	4054 78
5	407 129	1039 126	1685 123	2285 119	2899 113	3210 110	3532 108	4075 102
7	381 182	1004 177	1646 172	2250 168	2862 162	3180 158	3499 155	4095 147
9	338 235	951 231	1599 226	2208 220	2802 213	3117 208	3422 203	4041 193
12	263 308	856 303	1485 297	2093 290	2693 283	2983 278	3314 272	3957 260
15	170 380	771 376	1381 371	1983 364	2587 356	2898 350	3219 343	3838 328
20	65 454	659 446	1242 437	1864 430	2443 422	2748 418	3100 413	3744 399
25		361 613	896 601	1464 588	2046 575	2363 567	2770 558	3455 539

Flow (GPM)

TORQUE (LB IN) 2770
SPEED (RPM) 558

140 cc / rev

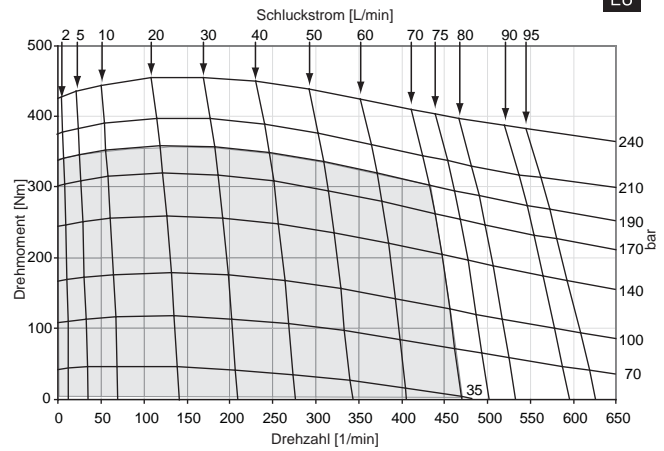

Cont.

Int.

Intermittent operation rating applies to 10% of every minute.

Fonctionnement interm. 10% max. de chaque minute d'utilisation.

Performance data based on testing using 10W40 oil with a viscosity of 200 SUS at 54° C (130° F). Performance data is typical. Actual data may vary slightly from one production motor to another.

Les donnees sur les performances sont basees sur des tests utilisant de l'huile 10W40 d'une viscosite de 200 SUS a 54°C (130°F). Ces donnees correspondent a des situations typiques. Les donnees reelles peuvent varier legerement d'un moteur de production a l'autre.

Intermittierende Werte maximal 10% von jeder Betriebsminute.

Capacidad de funcionamiento intermitente valida para 10% por cada minuto.

Leistungsdaten sind gemessen mit SAE 10W40 bei einer Viskositat von 43,1 Cst bei 54°C. Geringfuegige Abweichungen von den Katalogdaten sind moeglich.

Datos tecnicos obtenidos con aceite 10W40 de 200 SUS de viscosidad a 54°C (130°F). Los datos proporcionados son valores tipicos. Los valores exactos reales podrian tener una pequena variacion entre distintos motores.

TL 0170

10.3 cu in / rev

PRESSURE (PSID)

	500	1000	1500	2000	2500	2750	3000	3500
.5	499 10	1226 10	1937 9	2656 7	3395 6	3760 5	4100 4	4750 2
1	530 21	1285 20	2005 19	2715 17	3437 16	3800 15	4164 13	4818 11
2	543 43	1282 41	2040 39	2770 38	3504 35	3871 34	4233 32	4890 29
3	546 64	1300 62	2065 60	2798 58	3532 55	3935 53	4271 52	4953 48
4	549 86	1311 83	2081 80	2827 78	3576 74	3970 72	4321 70	5001 66
5	542 108	1310 105	2091 102	2826 99	3575 95	3954 92	4344 90	5022 85
7	516 152	1275 148	2052 144	2791 140	3538 135	3924 132	4311 129	5042 123
9	473 196	1222 193	2005 189	2749 184	3478 178	3861 174	4234 169	4988 162
12	398 257	1127 253	1891 248	2634 242	3369 236	3727 232	4126 227	4904 217
15	305 317	1042 314	1787 310	2524 304	3263 297	3642 293	4031 286	4785 274
20	200 379	930 372	1648 365	2405 359	3119 352	3492 349	3912 345	4691 333
25		632 512	1302 502	2005 491	2722 480	3107 474	3582 466	4402 450

Flow (GPM)

TORQUE (LB IN) 3582
SPEED (RPM) 466

169 cc / rev

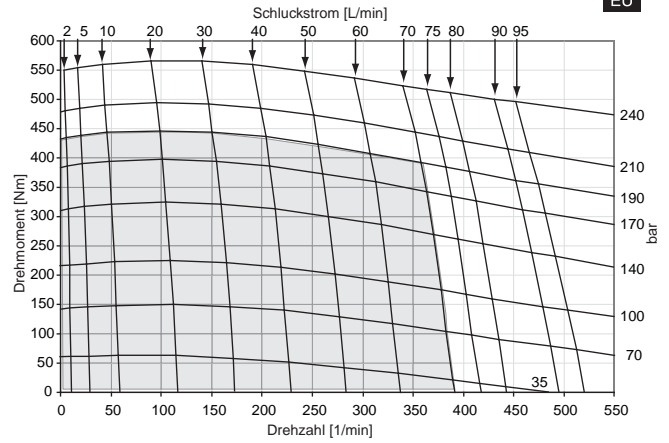

EU

Cont.

Int.

Intermittent operation rating applies to 10% of every minute.

Fonctionnement interm. 10% max. de chaque minute d'utilisation.

Performance data based on testing using 10W40 oil with a viscosity of 200 SUS at 54° C (130° F). Performance data is typical. Actual data may vary slightly from one production motor to another.

Les donnees sur les performances sont basees sur des tests utilisant de l'huile 10W40 d'une viscosite de 200 SUS a 54°C (130°F). Ces donnees correspondent a des situations typiques. Les donnees reelles peuvent varier legerement d'un moteur de production a l'autre.

Intermittierende Werte maximal 10% von jeder Betriebsminute.

Capacidad de funcionamiento intermitente valida para 10% por cada minuto.

Leistungsdaten sind gemessen mit SAE 10W40 bei einer Viskositat von 43,1 Cst bei 54°C. Geringfuegige Abweichungen von den Katalogdaten sind moeglich.

Datos tecnicos obtenidos con aceite 10W40 de 200 SUS de viscosidad a 54°C (130°F). Los datos proporcionados son valores tipicos. Los valores exactos reales podrian tener una pequena variacion entre distintos motores.

TL 0195

11.9 cu in / rev

PRESSURE (PSID)

	500	1000	1500	2000	2500	2750	3000	3500
.5	571 9	1353 7	2148 5	2938 3				
1	609 18	1417 16	2234 14	3032 12	3873 10	4250 8.5	4641 7	5400 4
2	621 37	1443 35	2267 33	3086 30	3923 27	4300 25.5	4712 24	5450 19
3	619 56	1448 54	2279 52	3104 49	3952 46	4331 44	4727 42	5490 37
4	615 75	1456 73	2303 71	3142 68	3963 64	4371 61.5	4761 59	5535 53.5
5	604 94	1448 92	2301 90	3148 87	3980 82	4400 79.5	4792 77	5587 72
7	571 132	1419 130	2272 127	3125 123	3965 119	4370 116	4784 113	5590 107
9	518 170	1364 168	2223 165	3072 161	3911 155	4310 152	4738 149	5549 142
12	437 226	1264 224	2113 221	2956 216	3792 210	4191 206.8	4620 203	5433 195
15	344 283	1164 281	2003 277	2835 272	3668 265	4062 261	4498 257	5314 248
20	189 343	1013 340	1833 333	2633 325	3461 319	3876 315	4295 310	5116 300
25		613 468	1397 460	2100 452	2903 443	3302 438	3750 433	4542 422

Flow (GPM)

TORQUE (LB IN) 3750
SPEED (RPM) 433

195 cc / rev

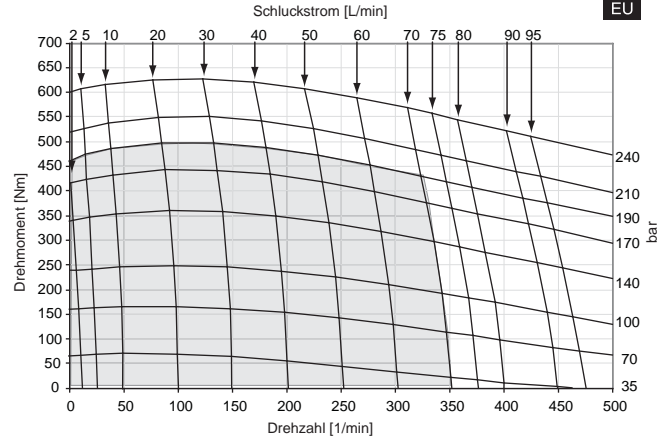

Cont.

Int.

Intermittent operation rating applies to 10% of every minute.

Fonctionnement interm. 10% max. de chaque minute d'utilisation.

Performance data based on testing using 10W40 oil with a viscosity of 200 SUS at 54° C (130° F). Performance data is typical. Actual data may vary slightly from one production motor to another.

Les donnees sur les performances sont basees sur des tests utilisant de l'huile 10W40 d'une viscosite de 200 SUS a 54°C (130°F). Ces donnees correspondent a des situations typiques. Les donnees reelles peuvent varier legerement d'un moteur de production a l'autre.

Intermittierende Werte maximal 10% von jeder Betriebsminute.

Capacidad de funcionamiento intermitente valida para 10% por cada minuto. Leistungsdaten sind gemessen mit SAE 10W40 bei einer Viskositat von 43,1 Cst bei 54°C. Geringfuegige Abweichungen von den Katalogdaten sind moeglich.

Datos tecnicos obtenidos con aceite 10W40 de 200 SUS de viscosidad a 54°C (130°F). Los datos proporcionados son valores tipicos. Los valores exactos reales podrian tener una pequena variacion entre distintos motores.

TL 0240

14.5 cu in / rev

PRESSURE (PSID)

	500	1000	1500	2000	2500	2750	3000	3500
.5	705 8	1662 8	2641 7	3635 6	4620 5	5095 5	5585 4	6536 3
1	752 16	1740 15	2740 14	3746 14	4739 13	5200 12	5712 11	6661 10
2	772 31	1783 30	2799 30	3818 29	4830 27	5300 26	5823 25	6793 23
3	769 47	1784 46	2812 45	3844 44	4863 42	5362 41	5857 40	6828 37
4	766 62	1797 62	2840 61	3887 59	4923 57	5384 56	5932 55	6910 51
5	751 78	1790 77	2842 76	3895 75	4933 72	5438 71	5951 69	6946 66
7	710 109	1758 108	2816 107	3875 105	4920 102	5425 101	5947 99	6958 95
9	649 141	1697 139	2762 138	3826 136	4875 132	5387 130	5908 128	6922 124
12	553 188	1583 186	2633 184	3675 182	4706 178	5219 175	5725 172	6734 167
15	438 235	1471 233	2499 230	3513 227	4520 223	4998 220	5526 217	6534 211
20	312 282	1350 279	2300 276	3305 273	4310 267	4732 264	5250 261	6200 254
25		1021 388	1837 384	2710 380	3735 373	4060 370	4500 365	5423 354

Flow (GPM)

TORQUE (LB IN) 4500
SPEED (RPM) 365

238 cc / rev

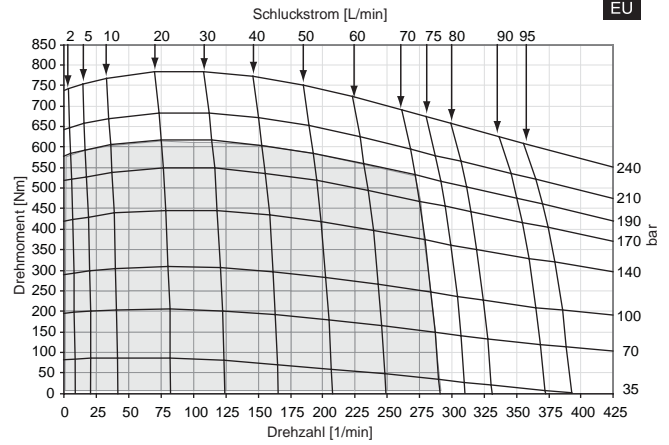

Cont.

Int.

Intermittent operation rating applies to 10% of every minute.

Fonctionnement interm. 10% max. de chaque minute d'utilisation.

Performance data based on testing using 10W40 oil with a viscosity of 200 SUS at 54° C (130° F). Performance data is typical. Actual data may vary slightly from one production motor to another.

Les donnees sur les performances sont basees sur des tests utilisant de l'huile 10W40 d'une viscosite de 200 SUS a 54°C (130°F). Ces donnees correspondent a des situations typiques. Les donnees reelles peuvent varier legerement d'un moteur de production a l'autre.

Intermittierende Werte maximal 10% von jeder Betriebsminute.

Capacidad de funcionamiento intermitente valida para 10% por cada minuto.

Leistungsdaten sind gemessen mit SAE 10W40 bei einer Viskosität von 43,1 Cst bei 54°C. Geringfügige Abweichungen von den Katalogdaten sind möglich.

Datos tecnicos obtenidos con aceite 10W40 de 200 SUS de viscosidad a 54°C (130°F). Los datos proporcionados son valores tipicos. Los valores exactos reales podrian tener una pequena variacion entre distintos motores.

TL 0280

17.1 cu in / rev

	PRESSURE (PSID)							
	500	1000	1500	2000	2500	2750	3000	3500
.5	887 7	2008 6	3147 5	4299 4	5458 3	6022 2	6599 2	7724 0
1	947 13	2093 13	3262 12	4424 11	5582 10	6144 9	6715 8	7812 6
2	982 27	2164 26	3361 25	4561 24	5745 22	6315 21	6902 19	8033 15
3	982 40	2167 39	3366 39	4570 37	5757 36	6356 34	6943 32	8070 28
4	984 53	2184 52	3397 51	4612 50	5820 48	6435 46	6985 45	8147 40
5	975 66	2185 65	3409 64	4634 62	5841 60	6417 58	7031 56	8201 52
7	931 93	2149 92	3381 90	4614 88	5829 85	6420 83	7029 81	8200 76
9	865 119	2083 118	3319 117	4556 114	5780 110	6396 108	6992 106	8193 101
12	746 159	1956 158	3190 156	4428 153	5661 149	6270 147	6885 143	8089 137
15	581 199	1800 198	3025 196	4255 192	5494 187	6128 184	6721 181	7912 174
20	415 239	1650 238	2850 235	4120 230	5350 224	5995 221	6570 217	7750 209
25	50 332	1240 330	2450 327	3700 320	5000 312	5650 307	6170 302	7340 290

Flow (GPM)

TORQUE (LB IN) 6170
SPEED (RPM) 302

280 cc / rev

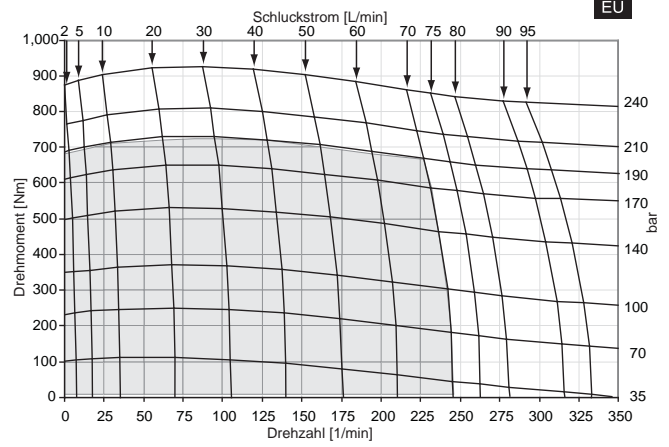

Cont.

Int.

Intermittent operation rating applies to 10% of every minute.

Fonctionnement interm. 10% max. de chaque minute d'utilisation.

Performance data based on testing using 10W40 oil with a viscosity of 200 SUS at 54° C (130° F). Performance data is typical. Actual data may vary slightly from one production motor to another.

Les donnees sur les performances sont basees sur des tests utilisant de l'huile 10W40 d'une viscosite de 200 SUS a 54°C (130°F). Ces donnees correspondent a des situations typiques. Les donnees reelles peuvent varier legerement d'un moteur de production a l'autre.

Intermittierende Werte maximal 10% von jeder Betriebsminute.

Capacidad de funcionamiento intermitente valida para 10% por cada minuto. Leistungsdaten sind gemessen mit SAE 10W40 bei einer Viskositat von 43,1 Cst bei 54°C. Geringfuegige Abweichungen von den Katalogdaten sind moeglich.

Datos tecnicos obtenidos con aceite 10W40 de 200 SUS de viscosidad a 54°C (130°F). Los datos proporcionados son valores tipicos. Los valores exactos reales podrian tener una pequena variacion entre distintos motores.

TL 0310

18.9 cu in / rev

PRESSURE (PSID)

	500	1000	1500	2000	2500	2750	3000	3500
.5	1031 6	2296 5	3579 5	4875 4	6178 3	6814 2	7463 2	8732 0
1	1091 12	2381 11	3694 11	5000 10	6302 9	6936 8	7579 7	8820 5
2	1126 24	2452 24	3793 23	5137 22	6465 20	7107 19	7766 17	9041 14
3	1126 36	2455 36	3798 35	5146 34	6477 32	7148 31	7807 29	9078 25
4	1128 48	2472 47	3829 46	5188 45	6540 43	7227 42	7849 40	9155 36
5	1119 60	2473 59	3841 58	5210 56	6561 54	7209 52	7895 51	9209 47
7	1075 84	2437 83	3813 81	5190 80	6549 77	7212 75	7893 73	9208 69
9	1009 108	2371 107	3751 106	5132 103	6500 99	7188 98	7856 96	9201 91
12	890 144	2244 143	3622 141	5004 138	6381 135	7062 132	7749 129	9097 124
15	725 180	2088 179	3457 177	4831 174	6214 169	6920 166	7585 164	8920 157
20	559 216	1938 215	3282 213	4696 208	6070 203	6787 200	7434 196	8758 189
25	194 300	1528 298	2882 295	4276 289	5720 282	6442 277	7034 273	8348 262

Flow (GPM)

TORQUE (LB IN) 7034
SPEED (RPM) 273

310 cc / rev

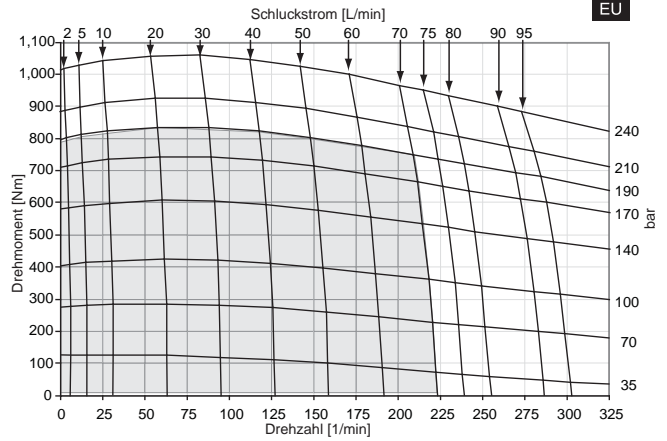

Cont.

Int.

Intermittent operation rating applies to 10% of every minute.

Fonctionnement interm. 10% max. de chaque minute d'utilisation.

Performance data based on testing using 10W40 oil with a viscosity of 200 SUS at 54° C (130° F). Performance data is typical. Actual data may vary slightly from one production motor to another.

Les donnees sur les performances sont basees sur des tests utilisant de l'huile 10W40 d'une viscosite de 200 SUS a 54°C (130°F). Ces donnees correspondent a des situations typiques. Les donnees reelles peuvent varier legerement d'un moteur de production a l'autre.

Intermittierende Werte maximal 10% von jeder Betriebsminute.

Capacidad de funcionamiento intermitente valida para 10% por cada minuto.

Leistungsdaten sind gemessen mit SAE 10W40 bei einer Viskosität von 43,1 Cst bei 54°C. Geringfügige Abweichungen von den Katalogdaten sind möglich.

Datos tecnicos obtenidos con aceite 10W40 de 200 SUS de viscosidad a 54°C (130°F). Los datos proporcionados son valores tipicos. Los valores exactos reales podrian tener una pequena variacion entre distintos motores.

TL 0360

22.2 cu in / rev

PRESSURE (PSID)

	500	1000	1500	2000	2500	2750	3000	3250
.5	1294 5	2821 5	4367 4	5926 3	7491 2	8259 2	9039 1	9810 1
1	1354 10	2906 10	4482 9	6051 8	7615 8	8381 7	9155 6	9947 6
2	1389 20	2977 20	4581 19	6188 18	7778 17	8552 16	9342 15	10152 14
3	1389 31	2980 30	4586 30	6197 29	7790 27	8593 26	9383 25	10190 24
4	1391 41	2997 40	4617 39	6239 38	7853 37	8672 36	9425 34	10262 33
5	1382 51	2998 50	4629 49	6261 48	7874 46	8654 45	9471 43	10288 42
7	1338 72	2962 71	4601 69	6241 68	7862 65	8657 64	9469 62	10293 61
9	1272 92	2896 91	4539 90	6183 88	7813 85	8633 83	9432 82	10261 79
12	1153 122	2769 122	4410 120	6055 118	7694 115	8507 113	9325 110	10144 108
15	988 153	2613 152	4245 151	5882 148	7527 144	8365 142	9161 139	9985 136
20	822 184	2463 183	4070 181	5747 177	7383 173	8232 170	9010 167	9847 164
25	457 255	2053 254	3670 251	5327 246	7033 240	7887 236	8610 232	9472 227

Flow (GPM)

TORQUE (LB IN) 8610
SPEED (RPM) 232

364 cc / rev

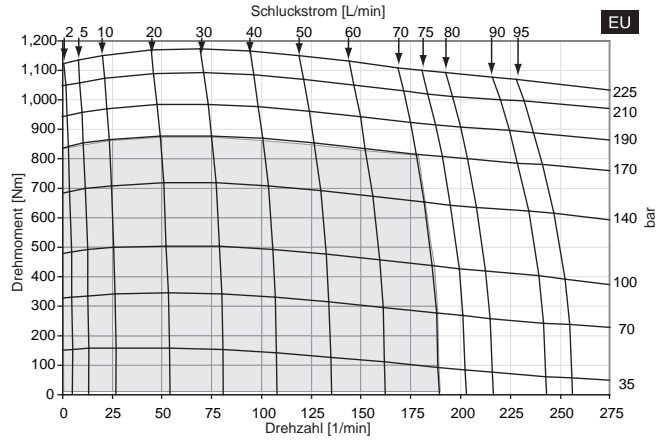

Cont.

Int.

Intermittent operation rating applies to 10% of every minute.

Fonctionnement interm. 10% max. de chaque minute d'utilisation.

Performance data based on testing using 10W40 oil with a viscosity of 200 SUS at 54° C (130° F). Performance data is typical. Actual data may vary slightly from one production motor to another.

Les donnees sur les performances sont basees sur des tests utilisant de l'huile 10W40 d'une viscosite de 200 SUS a 54°C (130°F). Ces donnees correspondent a des situations typiques. Les donnees reelles peuvent varier legerement d'un moteur de production a l'autre.

Intermittierende Werte maximal 10% von jeder Betriebsminute.

Capacidad de funcionamiento intermitente valida para 10% por cada minuto.

Leistungsdaten sind gemessen mit SAE 10W40 bei einer Viskosität von 43,1 Cst bei 54°C. Geringfügige Abweichungen von den Katalogdaten sind möglich.

Datos tecnicos obtenidos con aceite 10W40 de 200 SUS de viscosidad a 54°C (130°F). Los datos proporcionados son valores tipicos. Los valores exactos reales podrian tener una pequena variacion entre distintos motores.

Wheel Mount / Radnabengehäuse
Monture à roue/ Montaje de rueda

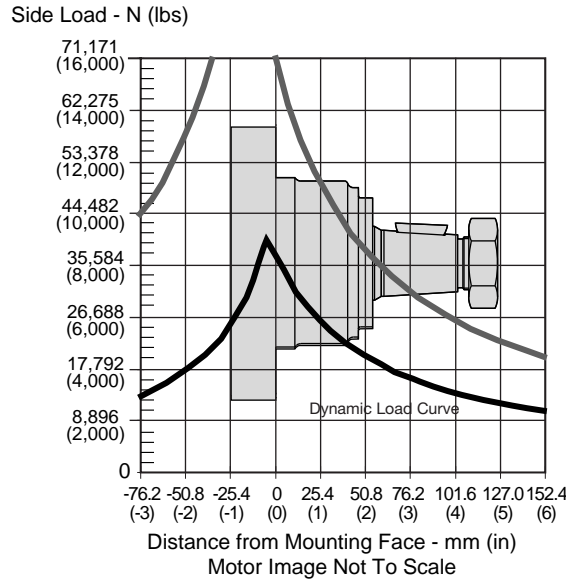

The dynamic side load curve is based on uni-directional steady state loads for L_{10} bearing life at 3×10^6 revolutions.

Die zulässige auslegbare radiale Wellenbelastungskurve ist unter ruhenden, einseitig statisch gerichteten Lastverhältnissen auf eine L_{10} Lebensdauer mit 3×10^6 Umdrehungen kalkuliert. La courbe de charge latérale permise se base sur des charges unidirectionnelles en régime permanent pour le roulement L_{10} à 3×10^6 révolutions. La curva de valores admisibles de carga lateral está basada en cargas constantes para cojinetes L_{10} a 3×10^6 revoluciones.

The maximum load curve is defined by bearing static load capacity. This curve should not be exceeded at any time including shock loads.

Die maximale radiale Wellenbelastungskurve ist definiert als maximale statische Last ohne Drehzahl. Sie gilt als Grenze und sollte keinesfalls überschritten werden. La courbe de charge maximale est définie par la capacité de charge statique portante. Cette courbe ne devrait être dépassée en aucun moment y compris pour les charges par à-coups. La curva de carga máxima queda definida por la capacidad de carga estática del cojinete. No se deben superar los valores de esta curva, ni siquiera con cargas provisorias de impacto.

Equation to Calculate the Expected Radial Bearing Life
Gleichung zur Ermittlung der Lagerlebensdauer

Equation to calculate the dynamic bearing life for a given load:
Bestimmung der erlaubten radialen Wellenbelastung mit vorgegebener Last

Use F_a , F_b and S in equation to determine hours of L_{10} bearing life.
Die Lebensdauer in Stunden ergibt sich durch einsetzen von F_a , F_b , und S in die nachstehende Formel.

$$L = \frac{3 \times 10^6}{60 \times S} \left\{ \frac{F_a}{F_b} \right\}^{3.33}$$

Where / Mit:

- S = Shaft Speed RPM / Abtriebswellendrehzahl in min^{-1}
- L = Life In Hours / Lebensdauer in Stunden
- F_a = Dynamic side load defined by above curve at a distance from mounting flange. / Erlaubte radiale Wellenbelastung als Function der Laenge
- F_b = Application side load. / Anwendungsseitige Wellenbelastung

Code: L 

Wheel, Front Brake Nose

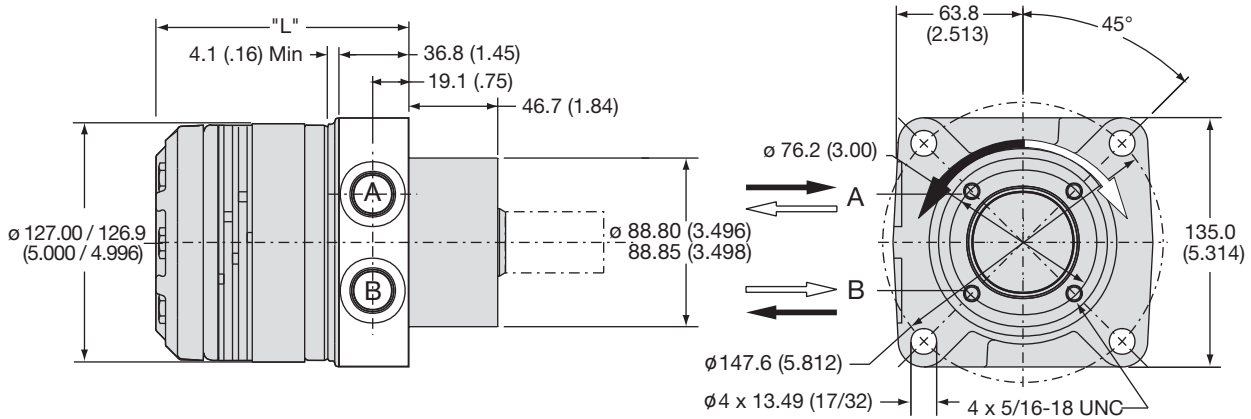

Code L	disp.	0140	0170	0195	0240	0280	0310	0360
Weight/Gewicht	kg	10.9	11.1	11.4	11.8	12.2	12.4	12.9
Poids/Peso	(lb)	(24.1)	(24.6)	(25.2)	(26.0)	(26.9)	(27.4)	(28.4)
Length	"L" mm	124	124	124	127	132	135	143
	"L" (in)	(4.83)	(4.83)	(4.83)	(4.99)	(5.16)	(5.30)	(5.58)

Code: U 

Wheel, Standard

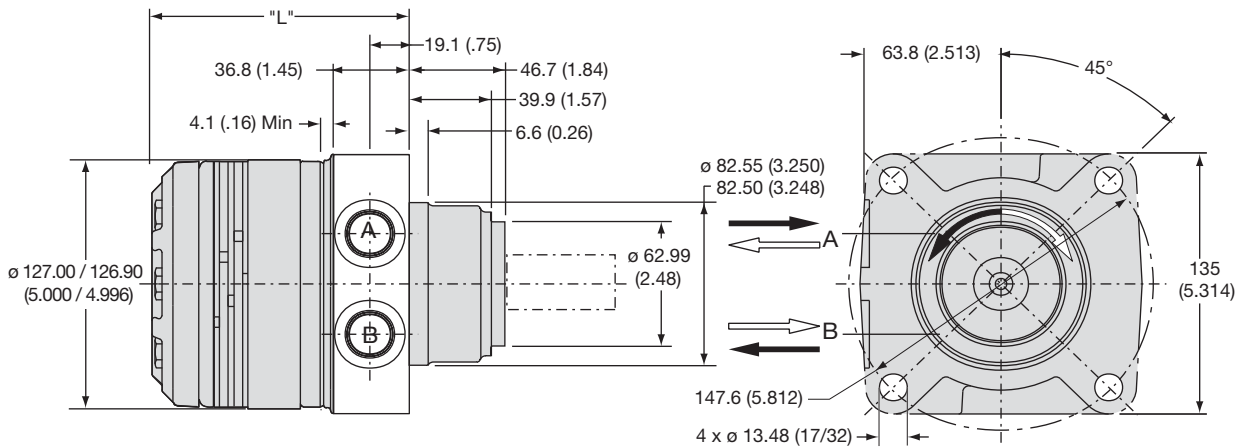

Code U	disp.	0140	0170	0195	0240	0280	0310	0360
Weight/Gewicht	kg	10.9	11.1	11.4	11.8	12.2	12.4	12.9
Poids/Peso	(lb)	(24.1)	(24.6)	(25.2)	(26.0)	(26.9)	(27.4)	(28.4)
Length	"L" mm	124	124	124	127	132	135	143
	"L" (in)	(4.83)	(4.83)	(4.83)	(4.99)	(5.16)	(5.30)	(5.58)

English equivalents for metric specifications are shown in ().

011 TL.indd, js



Code: S 

7/8-14 SAE O-Ring

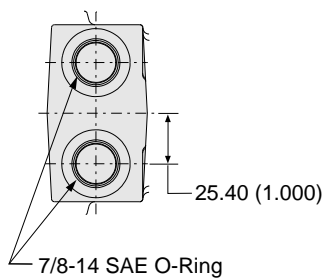

English equivalents for metric specifications are shown in ().

011 TL.indd, js

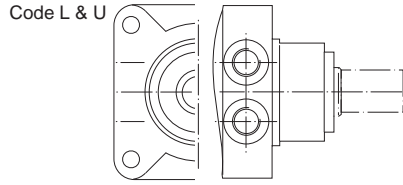

Code: 08 EU US

1 1/4" Tapered

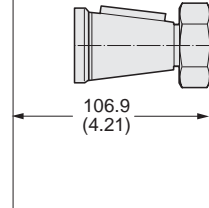

Code: 08 EU US

1 1/4" Tapered

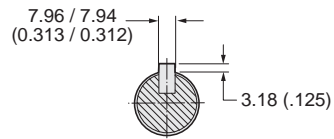
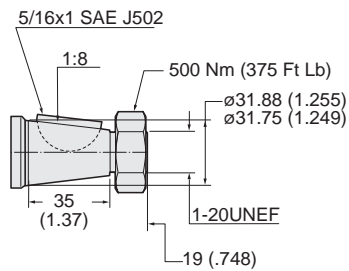

English equivalents for metric specifications are shown in ().

011 TL.indd, js