

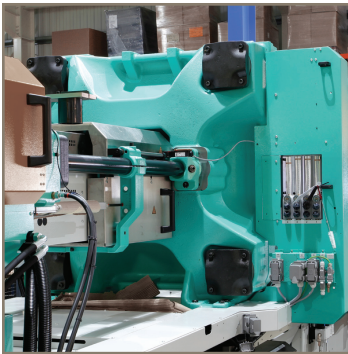

aerospace
climate control
electromechanical
filtration
fluid & gas handling
hydraulics
pneumatics
process control
sealing & shielding



Sentinel™

Portable Purification System



ENGINEERING YOUR SUCCESS.

Smaller foot print

Greater value

Improved efficiency

New circuitry

Patent pending



Sentinel™

Delivering big results in a compact, lightweight package, the Sentinel is the latest in fluid purification technology from Parker. The system guards over mission critical hydraulic and lubrication systems to effectively attack water, solids and gases while improving equipment health, productivity and reliability.

The smallest in Parker's family of oil purifiers, the Sentinel's unattended automatic operation minimizes energy consumption while extending the usable life of fluids. Equipped with Parker's IQAN MD3 platform control system, the Sentinel provides user confidence in system monitoring while delivering maximum performance on demand.



The Sentinel **removes** both free and dissolved water contamination from hydraulic fluids.

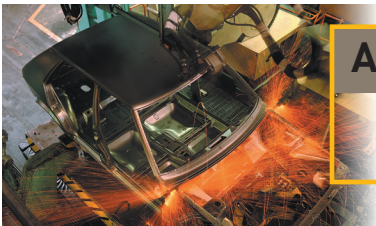

Automotive

Plastic Injection Molding
Lubrication Systems



Petrochemical

Lubrication Systems
Process Controls

Power Generation

Electrohydraulic Control
Systems



Aerospace

Ground Support Equipment
Test Stands



Marine

Propulsion, Steering Systems
Thrusters



Mining

Lubrication Systems

Features and Benefits

Compact Size

- Will fit through small doorways
- Makes marine applications possible

Automatic Operation

- Unattended use
- Reduces labor costs
- Increases operation time

316 Stainless Steel

- Used for primary wetted surfaces
- No corrosion
- Product reliability

Desiccant Breather

- Provides dry, clean air intake
- More efficient operation

Reverse Phase Switch

- Enables easy change of motor rotation if out of phase
- Ease of maintenance
- Prevents incorrect rotation



The Sentinel is designed for applications when **space** is at a premium.

Ecoglass Particulate Element

- Coreless, non-metallic construction
- Environmentally friendly, easy disposal

Diffusion Head/Manifold

- Flexibility with various fluid viscosities
- Excellent moisture removal efficiency

Forklift Guides/Lifting Eyes

- Safe and secure method of lifting
- Employee safety

Principles of Operation

Contaminated fluid is drawn through the Sentinel circuit by vacuum. The fluid is subjected to optimum vacuum, temperature and surface area to reduce the boiling point of water and convert water to water vapor. Optimum temperature is achieved with a low watt density heater. Maximum surface area is accomplished by passing the fluid through a unique diffusing column.

The fluid is protected from excessive heat by circulation for a fixed time period. When the pre-set time period is realized, the fluid discharges through high efficiency filtration to the main system reservoir. Water vapor that has been extracted from the system is exposed to a series of coalescers to eliminate any carryover oil vapor in the exhaust stream.

The process repeats until the desired steady state condition is achieved.

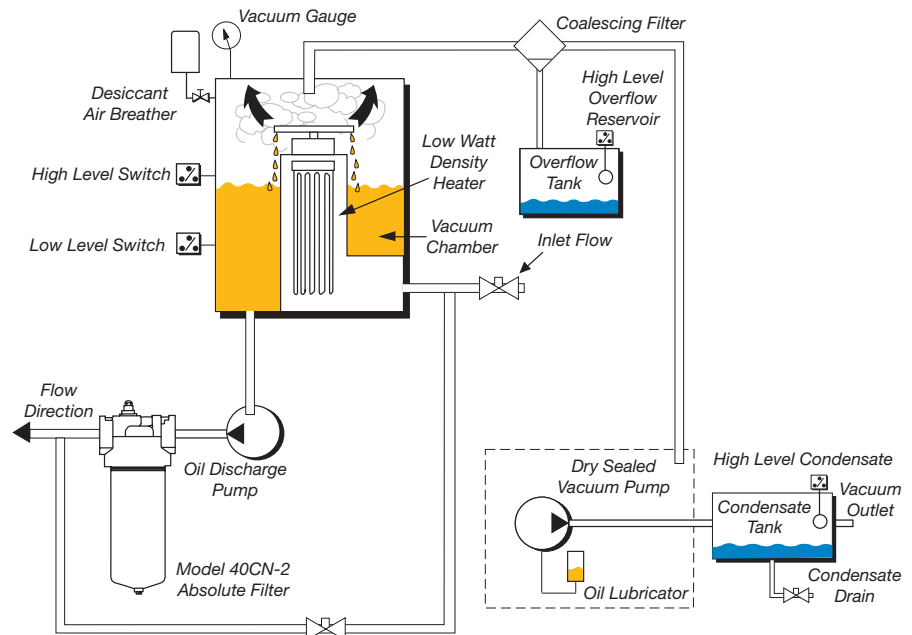

Water is one of the most common **contaminants** in a fluid system and one of the most damaging.

The operator can **customize** set points for various applications within their facility.

IQAN System

One of the highlights of the new Sentinel unit is the addition of Parker's IQAN system. The IQAN is an electronic PLC interface that controls many of the operating functions on the Sentinel. With IQAN, the operator can customize set points for various applications within their facility. Some of the user defined set points are:

- **sample rate**
- **moisture high limit**
- **moisture set point (low limit)**
- **temperature**
- **vacuum purge cycle**
- **auto condensate drain**
- **energy conserving features**

Sentinel mode will maintain constant dedicated vigilance to **control** water saturation in fluid while providing energy and labor savings.

Three modes of operation

1 Standard

Conventional purifiers require that the reservoir fluid be at 150°F before efficient water removal occurs. This could take hours if the ambient temperatures are low and the reservoir volumes are large. Standard mode allows for less power consumption by drawing the fluid through the unit in a unique cyclic method. The fluid is drawn into the unit and held while heat and vacuum act on it to remove water. Every two minutes the fluid is discharged and the process repeats, conserving power that otherwise would be necessary to bring the entire main system reservoir to the required 150°F.

2 Sentinel

Sentinel mode acts the same as standard mode other than it samples by drawing in fluid from the reservoir and testing the water saturation point. If the level is less than the desired set point, the system will hibernate until the next sampling point. The minimum time between sampling is 20 minutes and the maximum is 12 hours.

3 Sample

Once started, three batches of hydraulic fluid will be drawn into the system where overall moisture level and temperature are averaged and displayed on the IQAN screen.



Specifications

Flow Rate	5 gpm (18.9 lpm)
Dimensions	45" H x 19.5" W x 24" L (1143mm x 495mm x 686mm)
Weight	440 lbs. (200 kg)
Seal material	Fluorocarbon
Condensate tank	.5 gal (1.9 ltrs)
Dispersal elements	1
Minimum operating capacity	5 gal (18.9 ltrs)
Vacuum (max)	24 In/Hg
Viscosity (max)	2150 SUS (460 cSt)
Outlet pressure (max)	60 psi (4.1 bar)
Ports	3/4" JIC (male) inlet 3/4" JIC (male) outlet
FLA (full load amps)	16 amps @ 480VAC
Shipping Weight	640 lbs. (290 kg) maximum
Shipping Dimensions	56" H x 37" W x 37" L (1422mm x 940mm x 940mm)

Electrical Requirements:

230VAC, 3P, 60Hz
380VAC, 3P, 50Hz
415VAC, 3P, 50Hz
460VAC, 3P, 60Hz

Electrical Connection Port:

NEMA L16-30P Flanged Inlet

Hydraulic Connections:

Inlet: JIC 12
Outlet: JIC 12
Max Flow: 5 GPM
Water Drain: JIC 8

Vacuum Exhaust Port: JIC 8

Max Pressure: 60 psi (gauge)

Vibration: Band 1: 900 hz .5 g*/Hz

Storage: Max Temp 180°F, 100% rh

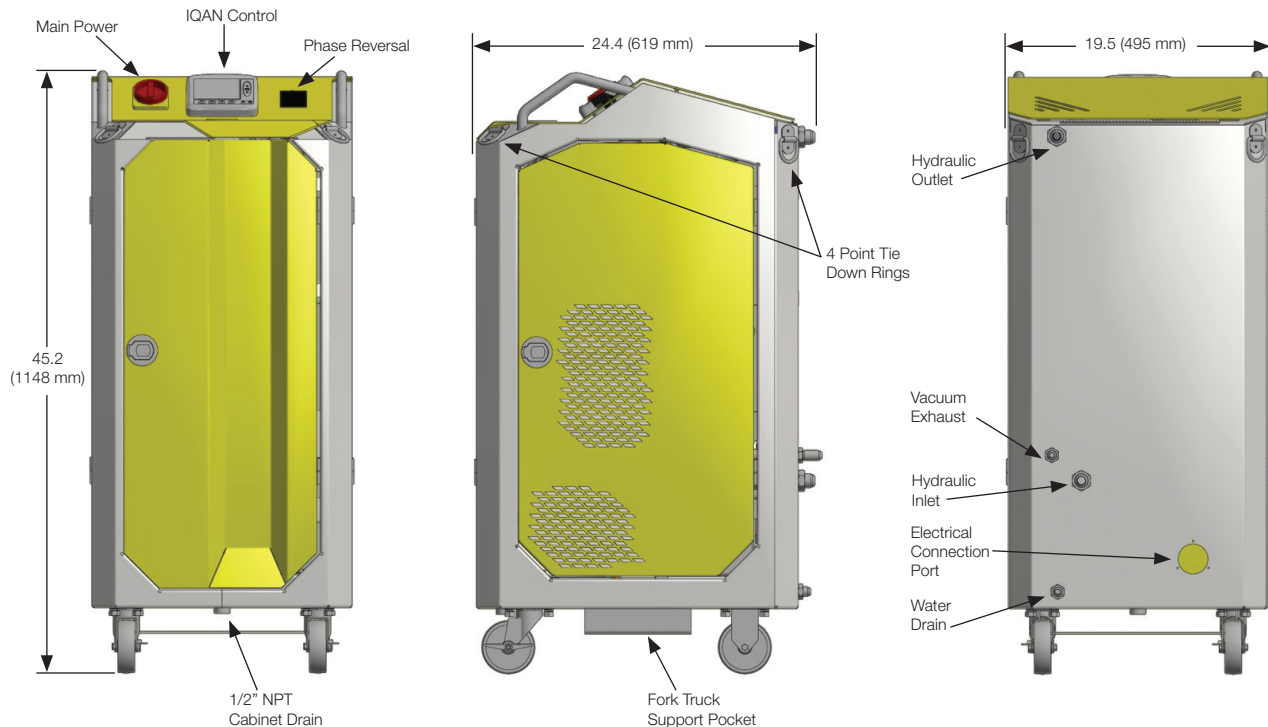

Note: Dimensions and weights are approximate and are for reference only.

Performance



Potential Contaminant	Sentinel Performance
Solid particulate	ISO Cleanliness Code 14/13/10 Attainable
Water	Removes 100% of free water, 90% of dissolved water
Air/Gases	Removes 100% of free air and gases, 90% of dissolved air and gases

Typical Performance	
Tank Size	55 gallon test drum
Run Time	16 hours
Fluid Type	Hydraulic
Water Content	Start: 7,000+ ppm (1%) Saturation pt: 5,000 ppm Stop: 200 ppm (0.005%)

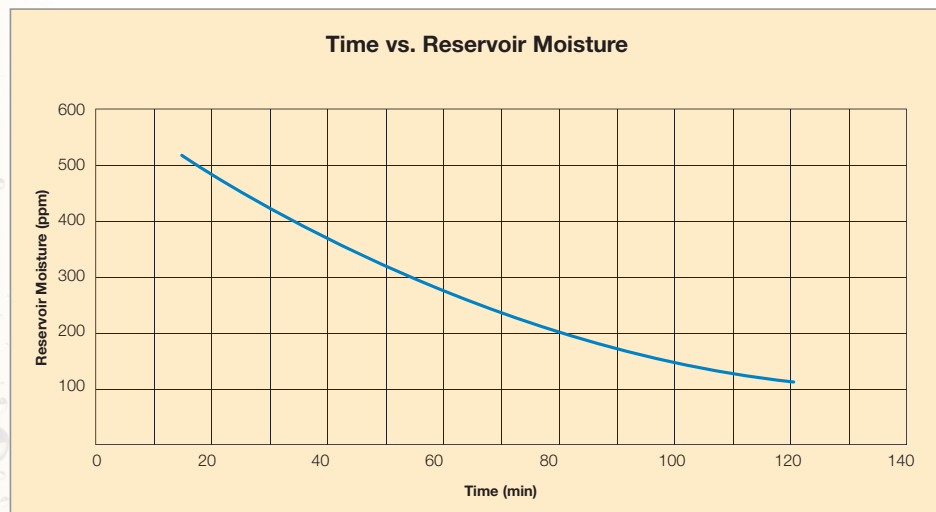
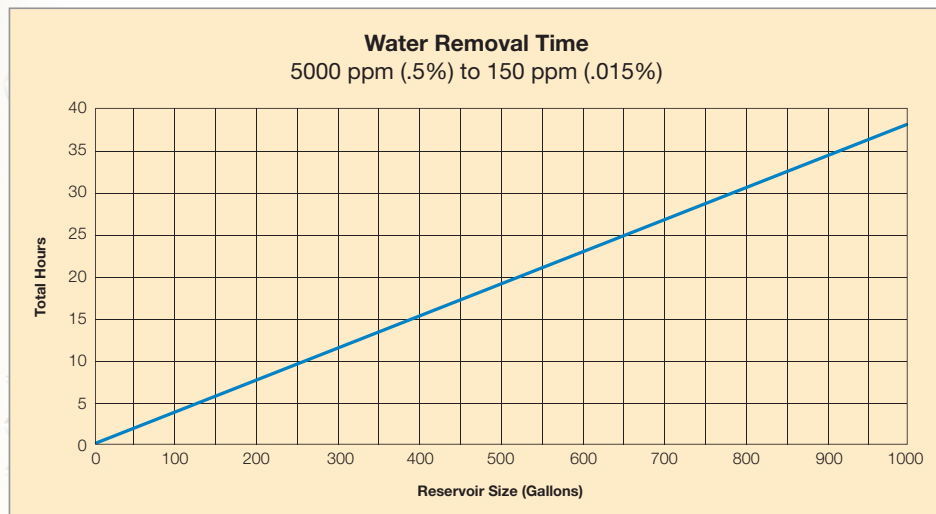

Ordering

Part Number	Description
Standard Unit	
943116*	380VAC, 3P, 50Hz
943118*	230VAC, 3P, 60Hz
943213*	460VAC, 3P, 60Hz
943494*	415VAC, 3P, 50Hz
Optional Accessories	
943236	Mounting Bracket Kit
943238	Cordset (pigtail end)
Service Parts	
936711Q	Hydraulic Particulate Element
943237	Service Kit (includes TriCeptor air breather, hydraulic particulate element, coalescing element, vacuum pump oil and vacuum pump filter element)
20072409	IQAN MD3
B-10235-0-460	Heater 460VAC
B-10235-0-380	Heater 380VAC
B-10235-0-230	Heater 230VAC
CEM3546T	Hydraulic Pump Motor
06F20C2218A1FPH80	Condensate Drain Valve
00424	Float Switch
MPS-V33N-PGAT	Vacuum Sensor
2820008	Pressure Sensor
40CN205QEVE2GS164	Filter
MS1504	Moisture Sensor
3349116565	Gear Pump

* Standard unit **includes**

- Dry sealed vacuum pump
- Coalescing filter
- 5 micron Ecoglass III element
- 6KW 3 phase low watt density heater
- 3" diameter rubber-wheel casters
- Consult factory for other options

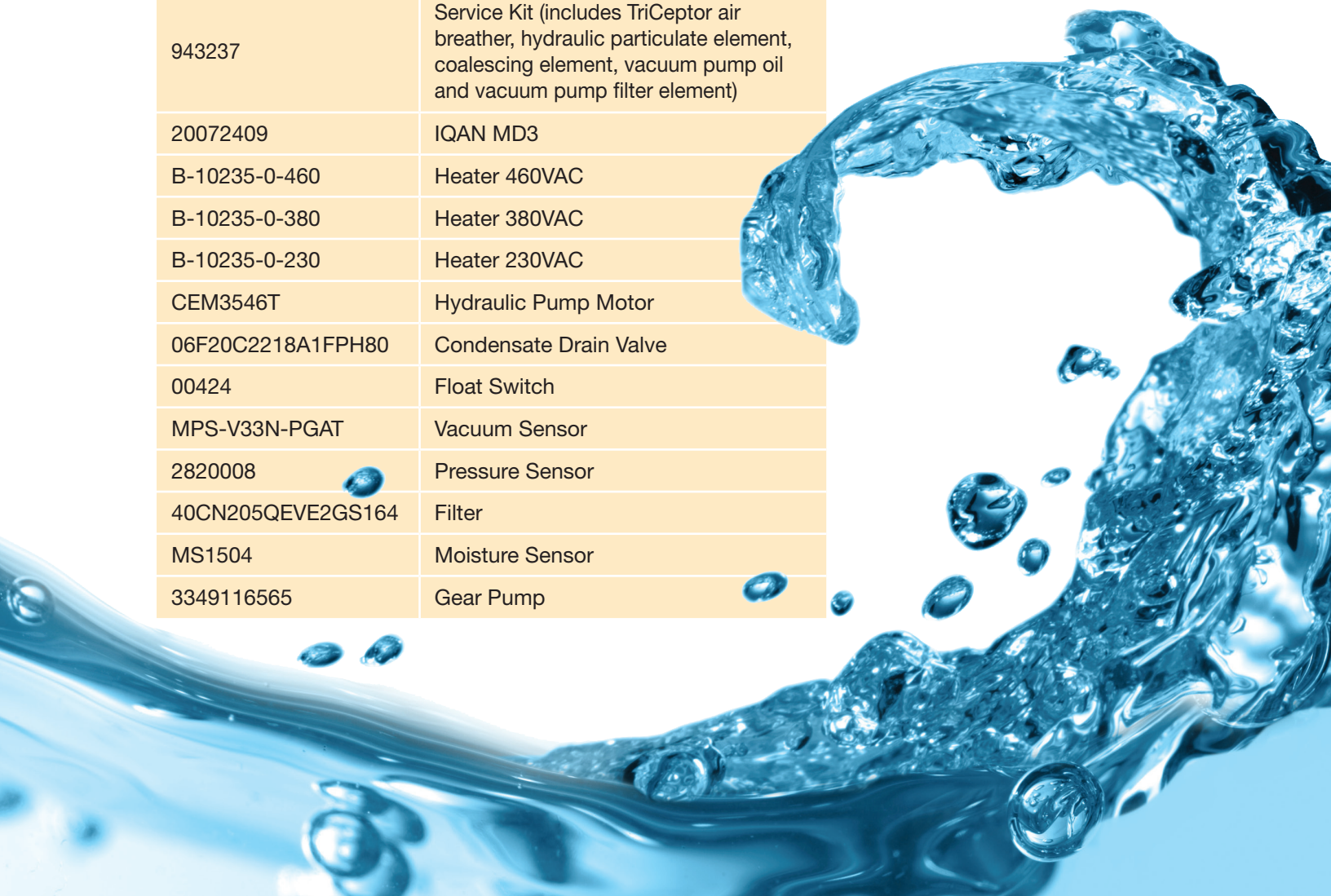

Total System Health Management

Diagnostic



Therapeutic



Preventive



When an issue is diagnosed, which goes beyond your standard preventive measures, the Sentinel can be just the therapy your system needs.

Sentinel™

Sentinel Specification Worksheet

Customer Name & Address: _____

Market & Application (i.e. Power Gen/Turbine Lube) _____

Fluid Type: _____ Brand: _____ Grade: _____

Viscosity: Min: _____ SUS/cSt @ _____ °F/°C

Max: _____ SUS/cSt @ _____ °F/°C

Normal: _____ SUS/cSt @ _____ °F/°C

Critical Hydraulic Component Types: (Check all that apply)

- | | |
|--|--|
| <input type="checkbox"/> Servo Valves | <input type="checkbox"/> Proportional Valves |
| <input type="checkbox"/> Vane and piston pumps/motors | <input type="checkbox"/> Gear pumps/motors |
| <input type="checkbox"/> Directional & pressure control valves | <input type="checkbox"/> Flow control valves |

Water concentration: Current % of water _____

Desired % of water _____

Sentinel/PVS location related to reservoir (reservoir above or below ground level & distance)

- 0-5 meters 5-10 meters ≥10 meters

System fluid operating temperature: _____ °F/°C

- Voltage options: 230 VAC, 3P 60Hz 380 VAC, 3P 50Hz
 460 VAC, 3P 60Hz 415 VAC, 3P 50Hz

- System Volume: 0-1000 gal - Sentinel or PVS185 1000-3000 gal - PVS600
 3000-7000 gal 7000-9000 gal
 >9000 gal

Any previous filtration problems with the application?

- Gelling High contamination levels High ambient environment

PVS model selected: _____



Parker Hannifin Corporation
Hydraulic Filter Division
16810 Fulton County Road #2
Metamora, OH 43540
phone 419 644 4311
www.parker.com/hydraulicfilter

Worldwide Filtration Manufacturing Locations

North America

Compressed Air Treatment Filtration & Separation/Balston

Haverhill, MA
978 858 0505
www.parker.com/balston

Finite Airtek Filtration Airtek/donnick hunter/Zander

Lancaster, NY
716 686 6400
www.parker.com/faf

Finite Airtek Filtration/Finite

Oxford, MI
248 628 6400
www.parker.com/finitefilter

Engine Filtration & Water Purification Racor

Modesto, CA
209 521 7860
www.parker.com/racor

Holly Springs, MS
662 252 2656
www.parker.com/racor

Beaufort, SC
843 846 3200
www.parker.com/racor

Village Marine, Sea Recovery, Horizon Reverse Osmosis

Carson, CA
310 637 3400
www.parker.com/watermakers

Hydraulic Filtration Hydraulic Filter

Metamora, OH
419 644 4311
www.parker.com/hydraulicfilter

Laval, QC Canada
450 629 9594
www.parkerfarr.com

Process Filtration donnick hunter Process Filtration

Oxnard, CA
805 604 3400
www.parker.com/processfiltration

Madison, WI
608 824 0500
www.scilog.com

Phoenixville, PA
610 933 1600
www.parker.com/processfiltration

Aerospace Filtration Velcon Filtration

Colorado Springs, CO
719 531 5855
www.velcon.com

Europe

Compressed Air Treatment donnick hunter Filtration & Separation

Gateshead, England
+44 (0) 191 402 9000
www.parker.com/dhfn

Parker Gas Separations

Etten-Leur, Netherlands
+31 76 508 5300
www.parker.com/dhfn

Hiross Zander

Padova Business Unit
Padova, Italy
+39 049 9712 111
www.parker.com/hz

Hiross Zander

Essen Business Unit
Essen, Germany
+49 2054 9340
www.parker.com/hz

Engine Filtration & Water Purification Racor

Dewsbury, England
+44 (0) 1924 487 000
www.parker.com/rfde

Racor Research & Development

Stuttgart, Germany
+49 (0)711 7071 290-10
www.parker.com/rfde

Hydraulic Filtration Hydraulic Filter

Arnhem, Holland
+31 26 3760376
www.parker.com/hfde

Ujala Operation

Ujala, Finland
+358 20 753 2500
www.parker.com/hfde

Condition Monitoring Centre

Norfolk, England
+44 (0) 1842 763 299
www.parker.com/hfde

Parker Kittiwake

West Sussex, England
+44 (0) 1903 731 470
www.kittiwake.com

Parker Procal

Peterborough, England
+44 (0) 1733 232 495
www.kittiwake.com

Process Filtration donnick hunter Process Filtration

Birtley, England
+44 (0) 191 410 5121
www.parker.com/processfiltration

Parker Twin Filter BV

Zaandam, Netherlands
+31(0)75 655 50 00
www.twinfilter.com

Asia Pacific

Australia

Castle Hill, Australia
+61 2 9634 7777
www.parker.com/australia

China

Shanghai, China
+86 21 5031 2525
www.parker.com/china

India

Navi Mumbai, India
+91 22 651 370 8185
www.parker.com/india

Parker Fowler

Bangalore, India
+91 80 2783 6794
www.johnfowlerindia.com

Japan

Tokyo, Japan
+81 45 870 1522
www.parker.com/japan

Parker Techno

Osaka, Japan
+81 66 340 1600
www.techno.taiyo-ltd.co.jp

Korea

Hwaseon-City
+82 31 359 0852
www.parker.com/korea

Singapore

Jurong Town, Singapore
+65 6887 6300
www.parker.com/singapore

Thailand

Bangkok, Thailand
+66 2186 7000
www.parker.com/thailand

Latin America

Parker Comercio Ltda. Filtration Division

Sao Paulo, Brazil
+55 12 4009 3500
www.parker.com/br

Pan American Division

Miami, FL
305 470 8800
www.parker.com/panam

Africa

Aeroporto Kempton Park, South Africa
+27 11 9610700
www.parker.com/africa

© 2014 Parker Hannifin Corporation. Product names are trademarks or registered trademarks of their respective companies.

Bulletin 2300-850A-NA (H)



Parker Hannifin Corporation
Filtration Group Global Headquarters
6035 Parkland Boulevard
Cleveland, OH 44124-4141
phone 216 896 3000
www.parker.com