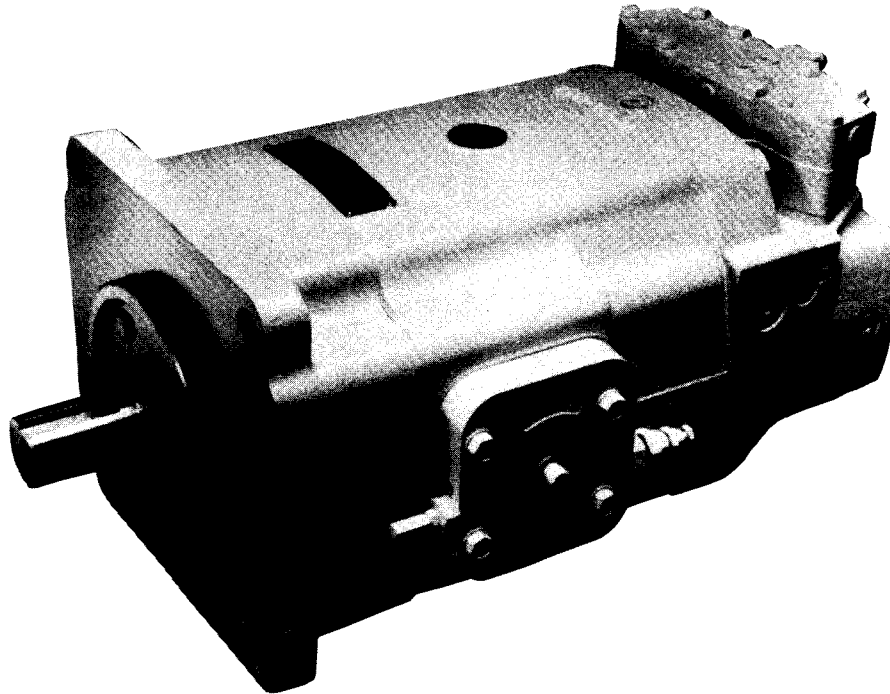

**Axial Piston Pump,  
Variable Displacement w/Auxiliary Package  
Gold cup****Series  
P11, 14 Design A****Service Information****CONTENTS**

	<b>PAGE</b>		<b>PAGE</b>
<b>INTRODUCTION</b>		<b>FIGURE 5 HOUSING AND BEARING ASSY.</b>	15
GENERAL	2	<b>FIGURE 6 HOUSING &amp; MOUNTING FLANGE</b>	15
DESCRIPTION	2	<b>FIGURE 7 PORT BLOCK ASSY.</b>	17
TABLE I CHARACTERISTICS	2	<b>FIGURE 8 PORT BLOCK TO HOUSING</b>	17
<b>INSTALLATION</b>		<b>FIGURE 9 GEROTOR &amp; BARREL HOLD-DOWN</b>	19
MOUNTING	3	<b>FIGURE 10 VALVE BLOCK (BEFORE 7-93)</b>	21
PIPING	3	<b>FIGURE 11 VALVE BLOCK (AFTER 7-93)</b>	23
SERVICE INFORMATION	3	<b>FIGURE 12 VALVE BLOCK FOR SERVO MTG. (BEFORE 7-93)</b>	26
FLUIDS	3	<b>FIGURE 13 VALVE BLOCK FOR SERVO MTG. (AFTER 7-93)</b>	29
MAINTENANCE	4	<b>FIGURE 14 SHAFT &amp; SHAFT SEAL, COUNTER BALANCE CONTROL &amp; CONTROL COVER ASSEMBLIES</b>	32
START UP PROCEDURE	4		
<b>TABLE II FLUID CONTAMINATION</b>	4	<b>IMPORTANT INSTRUCTIONS</b>	35
<b>TABLE III TROUBLESHOOTING</b>	5	<b>TEST PROCEDURES</b>	37
<b>TABLE IV REWORK LIMITS</b>	7	<b>ORDERING CODE</b>	42
<b>DISASSEMBLY</b>	7	<b>SEAL KIT</b>	
<b>ASSEMBLY PROCEDURES</b>		COMPLETE (PRIOR TO 4-1-90)	S23-12278
FIGURE 1 DRIVE SHAFT ASSY.	9	(AFTER 4-1-90)	S13-48001
FIGURE 2 BARREL AND AUX. SHAFT	10	VALVE BLOCK	S23-00135
FIGURE 3 ROCKER CAM PISTONS & RET.	13	HI-IQ VALVE BLOCK	S23-04226
FIGURE 4 BARREL & STROKING ASSY. TO MOUNTING FLANGE	14	SHAFT SEAL KITS	PAGE 34

**General**

The Denison Hydraulics Goldcup 11 and Goldcup 14 axial piston pumps feature advance design concepts which are time proven and provide for advance pumping and control concepts. The instructions contained in this manual cover complete disassembly and reassembly of the unit. Before proceeding with the disassembly or reassembly of any unit, this manual should be studied in order to become familiar with proper order and parts nomenclature.

**Description**

The use of a rocker cam to control the pump displacement provides a small package size, reduces wear, and speeds control response. The control vane actuator eliminates linkage and backlash inherent in typical stroking cylinder designs.

Standard controls for the Goldcup units are Rotary Servo and Compensator Over-Ride. Additional optional controls are also available.

**TABLE I TYPICAL CHARACTERISTICS**

Specification	Term	Goldcup 11	Goldcup 14
Displacement at Max. angle	in. <sup>3</sup> /rev.	11.00	14.00
	cc <sup>3</sup> /rev	(180)	(229)
Pressure Ports A & B max. continuous	psi	5000	5000
	bar	(345)	(345)
max. intermittent	psi	6000	6000
	bar	(414)	(414)
Speed, max. continuous @ full stroke - 50% stroke	RPM	2400	2400
		2800	2800
Flow, Ports A or B @ 1800 RPM (theoretical)	GPM	85.7	109
	l/min.	(324,4)	(412,9)
Flow, Auxiliary pump @ 1800 RPM (theoretical)	GPM	16.68	16.68
	l/min.	(63.12)	(63.12)
<i>*Aux. pump replenishing pressure</i>	psi	180-220	180-220
	<i>replenish pressure minus case pressure</i>	<i>bar</i>	<i>12.4-15.2</i>
<i>*aux. pump servo pressure range</i>	psi	340-440	340-440
	<i>servo pressure minus case pressure</i>	<i>bar</i>	<i>23.5-30.3</i>
<i>at 0 discharge pressure</i>			
<i>*aux. pump servo pressure range</i>	psi	540-640	540-640
	<i>servo pressure minus case pressure</i>	<i>bar</i>	<i>37.2-44.1</i>
<i>at 5000 psi, 345 bar discharge pressure</i>			
<i>*aux. pump servo pressure range</i>	psi	500-600	500-600
	<i>for HI-IQ control units servo pressure</i>	<i>bar</i>	<i>34.5-41.4</i>
<i>minus case pressure- at system pressure</i>			
	<i>range 0 to 5000 psi, 354 bar</i>		
<b>OPEN CIRCUIT PUMPS</b>			
<i>All do not have replenish relief poppets in valve block so replenish pressure approximately equals case pressure.</i>			
<i>All without the 900 control at 1000 psi, 69 bars discharge pressure have servo pressure minus case pressure = 200 to 250 psi, 13.8 to 17.2 bars.</i>			
<i>All without the 900 control at 5000 psi, 345 bars discharge pressure have servo pressure minus case pressure = 450 to 550 psi, 31.0 to 37.9 bars.</i>			
<i>All with the 900 control have servo-case pressure = 400 to 450 psi, 27.6 to 31.0 bars at all discharge pressure.</i>			
Mounting-4 bolt flange	SAE	E	E
Shaft-Spline/Keyed	SAE	E	E
Weight w/rotary servo	lbs.	325	325
	kg.	(147)	(147)

**Inlet Pressure, Minimum** — as measured at pump inlet flange with petroleum base fluids.

P11V MINIMUM INLET PRESSURE						
Speed Rpm	*Gauge Pressure				Absolute Pressure	
	psig	bar	in. Hg.	mm Hg.	psig	bar
*1200	-3	-0.20	-6	-152	11.7	.8
*1500	-3	-0.20	-6	-152	11.7	.8
1800	0	0	0	0	14.7	1.01
2100	5.3	0.37	10.8	274.3	20.0	1.38

P14V MINIMUM INLET PRESSURE						
Speed Rpm	*Gauge Pressure				Absolute Pressure	
	psig	barG	in. Hg.	mm Hg.	psia	barA
*1200	-3	-0.20	-6	-152	11.7	.8
*1500	-3	-0.20	-6	-152	11.7	.8
1740	0	0	0	0	14.7	1.01
1800	1	.07	2.0	52	15.7	1.08
2100	5.3	0.37	10.8	346	21.4	1.48

\* Above gauge pressure values are specified for sea level. Increase gage pressure 1 in. Hg.(25.4 mm Hg.) for each 1000 ft. (304.8 m) of altitude.

## Mounting

This pump is designed to operate in any position. The mounting hub and four bolt mounting flange are in full conformance with SAE standard. The pump shaft must be in alignment with the shaft of the driven load and should be checked with a dial indicator. The mounting pad or adaptor into which the fluid pump pilots must be concentric with the pump shaft to prevent bearing failure. This concentricity is particularly important if the shaft is rigidly connected to the driven load without a flexible coupling.

## Shaft Information

**Splined:** The shafts will accept a maximum misalignment of 0.006" TIR (.15 mm). Angular misalignment at the male and female spline axes must be less than  $\pm .002$  (0.05 mm) per one inch (25.4 mm) radius. The coupling interface must be lubricated. Denison Hydraulics recommends lithium molydisulfate or similar grease. The female coupling should be hardened to 27-45 Rc and must conform to SAE-J498B (1971) Class 1 flat root side fit.

**Keyed:** High strength heat treated keys must be used. Replacement keys must be hardened to 27-34 Rc. The key corners must be chamfered .030"-.040" (.75-1 mm) at 45° to clear radii that exist in the keyway.

**Keyed** types of shafts will accept a side load of 300 lbs. (136 kg) at the center of the key, with a B10 life of 10,000 hours at 1800 RPM or 318 lbs. (144 kg) with a B10 life of 10,000 hours at 1500 RPM.

## Piping

Connect inlet and outlet lines to the port block of the pump. The fluid connections are:

<b>System Ports:</b>	1.5" (38.10 mm) 6000 PSI (414 bar), SAE 4 bolt flange
<b>Open loop inlet:</b>	2 1/2" (63.5 mm), 3000 PSI (207 bar), SAE 4 bolt flange
<b>Other:</b>	SAE straight thread, O-ring seal. See installation drawing for sizes.

The maximum case pressure is 75 PSI (5.17 bar) continuous, 125 PSI (8.6 bar) intermittent. **Case pressures must never exceed inlet pressure by more than 25 PSI (1.7 bar).** When connecting case drain line make certain that drain plumbing passes above highest point of the pump before passing to the reservoir. If not, install a 5 PSI (.3 bar) case pressure check valve to be certain the case is filled with oil at all times.

The case leakage line must be of sufficient size to prevent back pressure in excess of 75 PSI (5.7 bar) and returned to the reservoir below the surface of the oil as far from the supply suction as possible. All fluid lines, whether pipe, tubing, or hose must be adequate size and strength to assure free flow through the pump. An undersize inlet line will prevent the pump from reaching full speed and torque.

An undersized outlet line will create back pressure and cause improper operation. Flexible hose lines are recommended. If

rigid piping is used, the workmanship must be accurate to eliminate strain on the pump port block or to the fluid connections. Sharp bends in the lines must be eliminated wherever possible. All system piping must be cleaned with solvent or equivalent before installing pump. Make sure the entire hydraulic system is free of dirt, lint, scale, or other foreign material. Flushing with a large temporary high pressure loop filter is recommended.

**CAUTION:** Do not use galvanized pipe. Galvanized coating can flake off with continued use.

## Service Information

These hydraulic products are designed to give long dependable service when properly applied and their systems properly maintained. These general instructions apply to typical systems. Specific instructions for particular equipment can be developed from them.

## Recommended Fluids

The fluid recommended for use in these pumps and motors has a petroleum base and contains agents which provide oxidation inhibition and anti-rust, anti-foam and de-aerating properties as described in Denison Hydraulics standard HF-1. Where anti-wear additive fluids are specified, see Denison Hydraulics standard HF-O.

## Viscosity:

Max. at cold start—7500 SUS (1600 Cst)  
(at low pressure, low flow, and, if possible, low speed)  
Max. at full power—750 SUS (160 Cst)  
Optimum for max. life—140 SUS (30 Cst)  
Minimum at full power—60 SUS (10 Cst)

## Viscosity Index:

90 V.I. minimum. Higher values extend the range of operating temperature but may reduce the service life of the fluid.

## Temperature

Determined by the viscosity characteristics of the fluid used. Because high temperatures degrade seals, reduce the service life of the fluid and create hazards, fluid temperatures should not exceed 180°F (82°C) at the case drain.

### Alternate Fluids

Some applications require fire-resistant fluids. They will give good service if the system is originally designed for their use. Permissible fire resistant fluids include:

Type	Denison Hydraulics Standard
Water-in-oil invert emulsions	HF-3
Water glycol solutions	HF-4
Phosphate esters	HF-5

Consult Denison Hydraulics for design requirements and warranty limitations for service with this class of fluids.

See Denison Hydraulics bulletin 2002 for more information.

### Maintenance

This pump is self-lubricating and preventative maintenance is limited to keeping system fluid clean by changing filters frequently. Keep all fittings and screws tight. Do not operate at pressures and speeds in excess of the recommended limit. If the pump does not operate properly, check the Trouble Shooting Chart before attempting to overhaul the unit. Overhauling is relatively simple and may be accomplished by referring to the Disassembly, Rework Limits of Wear Parts and Assembly Procedures.

### Fluid Cleanliness

Fluid must be cleaned before and continuously during operation by filters that maintain a cleanliness level of NAS 1638 Class 8. This approximately corresponds to ISO 17/14.

### Start Up Procedure for New Installation

1. Read and understand the instruction manual. Identify components and their function.
2. Visually inspect components and lines for possible damage.
3. Check reservoir for cleanliness. Drain and clean as required.
4. Check fluid level and fill as required with filtered fluid at least as clean as that recommended. Fill pump case with clean oil prior to starting.
5. Check alignment of drive.
6. Check oil cooler and activate it, if included in circuit. Check fluid temperature.
7. Reduce pressure settings of compensator and relief valve. Make sure accurate pressure readings can be made at appropriate places.
8. If solenoids in system, check for actuation.
9. Start pump drive . Make sure pump fills properly.
10. Bleed system of air. Recheck fluid level.
11. Cycle unloaded machine at low pressure and observe actuation (at low speed, if possible).
12. Increase pressure settings gradually in steps. Check for leaks in all lines especially in pump and motor inlet lines.
13. Make correct pressure adjustments.
14. Gradually increase speed. Be alert for trouble as indicated by changes in sounds, system shocks and air in fluid.
15. Equipment is operational.

**Trouble Shooting**

Component problems and circuit problems are often inter-related. An improper circuit may operate with apparent success but will cause failure of a particular component within it.

The component failure is the effect, not the cause of the problem.

This general guide is offered to help in locating and eliminating the cause of problems by studying their effects:

<b>Effect of Trouble</b>	<b>Possible Cause</b>	<b>Fault Which Needs Remedy</b>
Noisy Pump	Air in Fluid	Leak in suction line Low fluid level Turbulent fluid Return lines above fluid level Gas leak from accumulator Excessive pressure drop in the inlet line from a pressurized reservoir Suction line strainer acting as air trap
	Cavitation in rotating group	Fluid too cold Fluid too viscous Fluid too heavy Shaft speed too high Suction line too small Suction strainer too small Suction strainer too dirty Operating altitude too high Boost or replenishment pressure too low Replenishment flow too small for dynamic conditions
	Misaligned shaft	Faulty installation Distortion in mounting Axial interference Faulty coupling Excessive overhung loads
	Mechanical fault in pump	Piston and shoe looseness or failure Bearing failure Incorrect port plate selection or index Eroded or worn parts in the displacement control
Erosion on barrel ports and port plate	Air in fluid	See above
	Cavitation	See above
High wear in pump and motor	Excessive loads	Reduce pressure settings Reduce speeds
	Contaminant particles in fluid	Improper filter maintenance Filters too coarse Introduction of dirty fluid to system Reservoir openings Improper reservoir breather Improper line replacement
	Improper fluid	Fluid too thin or thick for operating temperature range Breakdown of fluid with time/temperature/shearing effects Incorrect additives in new fluid Destruction of additive effectiveness with chemical aging
	Improper repair	Incorrect parts Incorrect procedures, dimensions, finishes

(Continued)

Effect of Trouble	Possible Cause	Fault Which Needs Remedy
High Wear in pump and motor	Unwanted water in fluid	Condensation Faulty breather/strainer Heat exchanger leakage Faulty clean-up, practice Water in makeup fluid
Pressure shocks	Cogging load Worn relief valve	Mechanical considerations Needed repairs
	Worn compensator Slow response in check valves	Needed repairs Replace or relocate
	Excessive decompression energy rates	Improve decompression control
	Excessive line capacitance (line volume, line stretch, accumulator effects)	Reduce line size or lengths. Eliminate hose
	Barrel blow-off	Recheck pump hold-down, rotating group, drain pressure
Heating of fluid	Excessive pump leakage	Recheck case drain flow and repair as required Fluid too thin Improper assembly, port timing
	Relief valve	Set too low (compared to load or compensator) Instability caused by back pressure, worn parts
	Compensator	Set too high (compared to relief) Worn parts
	Pump too large for fluid needs	Select smaller pump displacement
	Heat exchanger	Water turned off or too little flow Water too hot Fan clogged or restricted Efficiency reduced by mud or scale deposits Intermittent hydraulic fluid flow
	Reservoir	Too little fluid Improper baffles Insulating air blanket that prevents heat rejection Heat pickup from adjacent equipment



The instructions contained in this section cover a complete teardown of the subject pump. Disassemble only as far as necessary to replace or repair any worn parts.

**Disassembly**

Position pump unit so that valve block assembly is on top. A bench or similar suitable surface capable of supporting unit should be used. Disassembly area should be clean.

**Valve Block**

**See Figure 14**

1. Remove the eight hex head cap screws (18) and lift the entire block assembly from the port block.

**Valve Cover**

**See Figure 10**

1. Remove the four screws (39) to separate the cover (21) from the block (11). Do not remove the check valves (19).
2. Remove plugs (43), (36) and pin (40). Remove the 8-32 nut from the bottom of cover (21) to remove filter assembly (34).
3. Remove housing (29) and O-Ring (28). Remove items (30), (31), and (33) as a unit. Insert a small brass rod thru the hole in the housing and tap out piston (27) and O-ring (26).
4. Remove spring (25) and cone (24). Remove seat (23) and O-ring (22).

**NOTE:** Seat is made for hex wrenching. Use 1/2" 6 point socket with 1/4" drive.

**Valve Block**

1. Remove O-ring (37) and replenishing relief valve (41). Inspect orifices (12) visually to insure they are open. Do not remove unless damage or clogging is apparent.
2. Remove springs (16), (17) and (18). Remove retainer (15) and poppets (13) and (14).

**Retainer Plate**

1. Remove the four screws (4) from the plate (6) and (11). Remove gasket (7).
2. Remove seats (8) and (9). Do not remove roll pins (5) and (10) unless replacements are needed.

**Controls**

**See Figure 14**

1. Remove the four screws (15) from the side cover (17) and remove the input shear seal valve assembly.
2. Remove the four screws (15) from the side cover (16) and remove the counter balance shear seal assembly.
3. Remove the two screws (13) and remove the balance stem (9) and balance plate (11).

**Barrel Hold-down and Gerotor Assembly**

**See Figure 9**

1. Remove snap ring (20), end cover (18) and "O" ring (19).
2. Remove pin (17), hold-down nut (16), thrust washers (13), bearing (14) and seal ring (15).
3. Remove pressure plate (12), "O" rings (10) and (11), and side plate assembly (9).
4. Remove servo gerotor assembly (7), dowel pin (8), key (6), and center port plate (4).
5. Remove replenishing gerotor (3), key (2) and side plate (1).

**Port Block**

**See Figure 8**

1. Remove four screws (1) that secure the port block (2) to the housing (6). Use caution when removing screws on valve block side to prevent marring valve block face.

(Continued)

**TABLE IV Rework Limits of Wear Parts**

	<b>Max. Rework From Original</b>	<b>Min. Dimension</b>
<b>11 and 14 in<sup>3</sup></b>	<b>Dimension</b>	<b>After Rework</b>
Port plate face	.010" (.254 mm)	.705" (17.9 mm)
Shoe retainer face	.005" (.127 mm)	.432" (10.97 mm)
Piston shoe face (pocket)	.010" (.254 mm)	.010" (.254 mm)
Creep plate face	.010" (.254 mm)	.240" (6.1 mm)
Face plate	None	Replace

**IMPORTANT:**

The port plate both faces finish must be 25 microinches, (635 μm) flat within .00006 (.0015 mm) and parallel within .001 (.0254 mm) T.I.R. The creep plate wear face finish must be 10 microinches, (254 μm) flat within .0002 (.0381 mm) and parallel to the backside within .0005 (.0127 mm) T.I.R.

The shoe retainer wear face finish must be 32 microinches, (813 μm) and flat within .0015 (.0381 mm) (must not be convex).

The piston shoes wear face finish must be 5 microinches, (127 μm) and must be lapped in a set with the retainer plate, all shoe sole thicknesses to be within .001 (.0254 mm) after lapping. The maximum permissible shoe and piston axial looseness is .010 (.254 mm).

**The special retaining ring service kit (S23-12547) may be required to control shoe holddown clearance.**

**Note:** port plate will in some instances adhere to port block upon disassembly.

2. Remove port block (2) and gasket (5). Remove port plate (4) and port plate pins (3).

### See Figure 7

1. Remove the check valve assemblies (7) from the port block (1).
2. Remove needle bearing (2) from the port block.
3. Remove plugs (8, 10 and 12).
4. Remove two screws (4), lockwashers (5), check rings (3), and clamps (6). (Solid ring assemblies in open loop pumps.)

### Barrel and Auxiliary Shaft

1. Remove face plate and pins (2 and 1, fig. 6) from face of barrel assembly.
2. Remove the barrel assembly (1, fig. 4) by grasping the auxiliary shaft and lifting the complete assembly out of the housing.

### Drive Shaft

**See Figure 14 (See page 34 for removing old shaft seal parts - prior to april 1990)**

**Note:** Pump rocker cam assembly must be centered before removing shaft.

1. Remove the four screws (8) and gaskets (7). Remove seal retainer (6), O-ring (5) and the stationary part of the shaft seal (4). Refer to view of item 4. Carefully remove the carbon ring and the remainder of the shaft seal from the shaft.

**Caution:** Do not scratch seal surface of shaft when removing seal.

Remove snap ring (3) and the shaft and bearing assembly (1). Remove shim (2).

### Housing

**See Figure 6**

After shaft assembly has been removed, position the unit on end with the mounting flange turned down.

1. Push the ends of the small tube lines away from the housing.

2. Lift the housing from the mounting flange, remove the gasket, and dowel pins from the mounting flange.

3. Do not remove the roll pins and the bearing from the housing unless the bearing is damaged and must be replaced.

### Rocker Cam and Control Stroking Assembly

**See Figure 4**

Remove the complete assembly (7) from the mounting cap (9) and position on a clean flat surface with the two tubes (2) in a horizontal position and located at the top. Mark the cam (22) and cradle (19) as indicated in Figure 3. These marks will determine positioning of parts during reassembly.

Carefully remove the small tube lines (5) and (6) from the cradle.

**Caution:** Do not bend these lines

### See Figure 3

Position the assembly in an upright position on the flat surface of the cradle (19). Remove the retaining ring (1) thrust washer (2), and flange bearing (3). Remove the piston and shoe assembly (4) and the creep plate (5) from the cam (22). Remove the two screws (12) that secure the two button head screws (9). Remove screws (9). Remove the servo input parts (6,7, 8, 10).

**Note:** Earlier units use differential screws which must be alternately loosened one turn at time.

Remove the four 1/2"(12.7mm) screws (11) and four 3/8" (9.5mm) screws (13) from the control covers (14R) and (14L). Remove the four dowel pins (15) and remove the two chambers (16). Remove the two special seals (18) and the four steel balls (17). Remove the two vane seal cartridge assemblies (25) and the four hold-down vanes (24) and springs (23) from the rocker cam (22).

Remove the rocker cam (22) from the cradle (19).

**Caution:** Do not remove the plugs from the rocker cam.



**Cleaning and Inspection**

1. All parts must be inspected and be free of material defects, dirt, scratches or any foreign material.
2. All parts must be cleaned with a suitable cleaning solvent and all holes and passages blown out with dry, clean, compressed air.
3. After cleaning and inspection, all parts must be covered with a light film of oil and protected from dirt and moisture. Excessive handling of internal parts should be avoided prior to assembly.
4. During assembly, lapped and ground surfaces must be lubricated with clean oil and protected from nicks or surface damage.

**Drive Shaft and Bearing**

1. Pass one retaining ring (3) over the internal end of drive shaft (1) and install in the groove near the shaft seal surface.

**Caution:** Do not pass the ring over the seal surface.

2. Slide the bearing (2) over the same end of the shaft and seat against the ring.

*Support only the inner race of the bearing and press on the coupling end of the shaft to install bearing.*

**Caution:** Do not use excessive force and distort or damage the retaining ring.

3. Install the other retaining ring (3) in the other retaining ring groove. Be sure that both rings are fully seated.

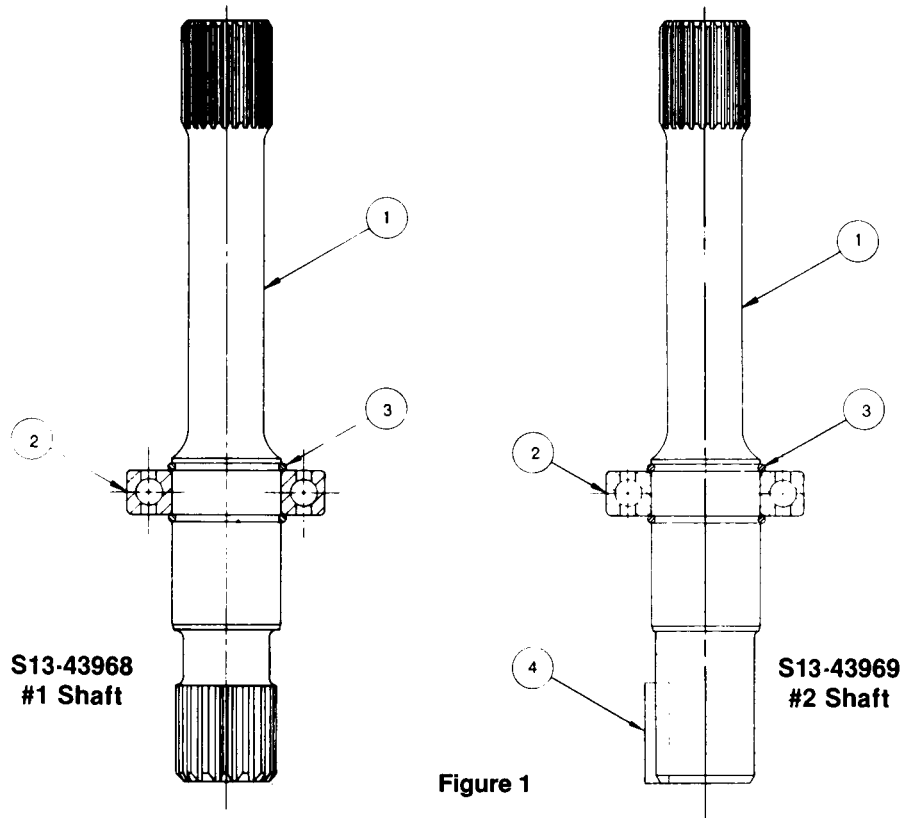

Figure 1

S13-43968 #3 Drive Shaft Assembly (Splined)  
 S13-43969 #2 Drive shaft Assembly (W/Keyway)

Item	Description	Part No.	Qty.	
			#3	#2
1	#3 (Splined Drive Shaft)	033-71604	1	—
	#2 Keyed Drive Shaft	033-71601	—	1
2	Shaft Bearing	230-82148	1	1
3	Retaining Ring	033-71641	2	2
4	Square Key 7/16 x 1-1/2	033-71514	—	1

(11.1 x 38.1 mm)

**Barrel and Auxiliary Drive Shaft  
Figure 2**

1. Position the barrel (1) with the bores facing down on a clean surface.
2. Install holddown spring (3) into barrel counterbore.
3. Install spring retainer (5) into counterbore and seat against spring.
4. Install retaining ring (6) into barrel counterbore groove. Make sure retaining ring is fully seated in groove.
5. Position barrel stop (4) over auxiliary drive shaft (2). Turn barrel on side and install auxiliary drive shaft and barrel stop through barrel spline and holddown spring.

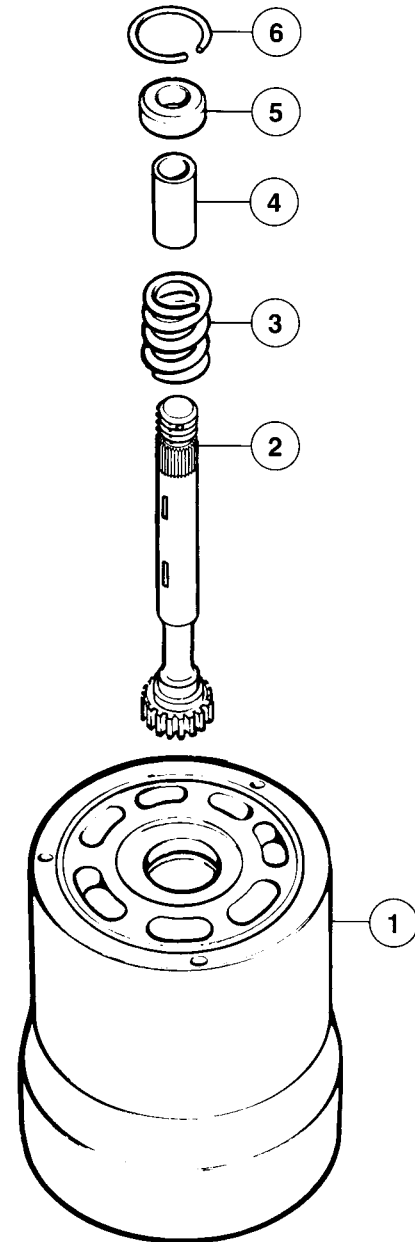

Figure 2

Item	Description	Part No.	Qty.	
			P11	P14
1	Barrel & Sleeve Assy. (P11)	S13-45381	1	—
	Barrel & Sleeve Assy. (P14)	S13-43965	—	1
2	Auxiliary Drive Shaft	033-71603	1	1
3	Holddown Spring	033-71562	1	1
4	Barrel Stop	033-71561	1	1
5	Spring Retainer	033-71560	1	1
6	Retaining Ring	033-71564	1	1

Consult Denison Hydraulics Service for parts prior to 1983 units.

**Rocker Cam Assembly  
FIGURE 3**

1. Position the cradle (19) on a clean flat surface with the large flat area down.
2. Position the rocker cam (22) on the cradle (19). Note marks made earlier to indicate top of rocker cam & cradle.

**Vane Seal Cartridges**

1. Place O-ring (25c) around spacer (25d) and insert in the vane seal (25b).
2. Insert check valve (25e) inside of spacer (25d) and assemble between the two backup plates (25a) with the notched V's exposed.
3. Install assembled cartridge in slot in cam as indicated in Figure 3. Repeat steps 1,2 and 3 on other side of cam.
4. Insert the four holddown vanes (24) and springs (23) in the slots on each side of the control vanes (25).

**NOTE:** Install nylon holddown vanes with the beveled edge sloping away from the vane seal cartridges.

**Control Chamber**

1. Position both control chambers (16) on a clean flat surface with seal grooves turned up. Drop the four steel balls (17) in the four counterbored holes at each end of the seal grooves.
2. Lubricate seals (18) and insert in seal grooves in control chamber (16).

**NOTE:** The tapered side of the seals must be pushed into the grooves and the ends must cover the steel balls.

3. Install the control chamber (16) with seal (18) and steel balls (17) assembled over the control vane (25). The seal must be against the cam. Rotate the chamber until it passes over the control vane assembly, then rotate in the opposite direction until the 3/8" dowel pins (15) can be pushed through the chamber (16) and into the cradle (19). Install chamber in the same manner on the other side of the cam.

**NOTE:** Two sets of chamber covers are available. The set marked CW must be installed in the right hand rotation pump and the set marked CCW must be used in the left hand rotation pump. **(Rotation is determined facing the shaft end of pump.)** The covers must be installed with the tubing holes and the tapped holes at the top of the unit.

4. Install chamber covers (14R) and (14L) on the control chambers (16) over the dowel pins (15). The covers must be installed with the override tube (25) holes at the top. Refer to the "T" marked on the rocker cam (22) and cradle (19).
5. Install two 1/2-13 hex head screws, (11) in each side and torque to 75 ft. lbs. (101.7 N•m)
6. Install two 3/8-16 hex head screws (13) in each side and torque to 30 ft. lbs. (40.7 N•m)

7. Install O-ring (20) and hex socket plug (21) in each cover.
8. Install tubes (26) in reamed holes in each cover. These tubes must be a tight fit in the chamber cover and in the port block. If tubes are loose, the ends can be expanded with a tapered punch.
9. Tap the tubes in place with a plastic mallet.

**Servo Assembly**

1. For "P" units, install two orifice screws (7) in the servo stem (6). For "V" units, install one orifice screw (7) as noted.
2. Install servo stem on rocker cam using screws (8). Torque to 70 in/lbs. (7.91 N•m)
3. Install two #10-24 button hd screws (9) into the servo plate (10).
4. Install servo plate with the button hd screws into the servo stem. Torque the screws to 30 in-lbs.(3.39 N•m). Lock screws (9) with set screws(12). Torque to 25 in-lbs. (2.8 N•m).

**NOTE:** Earlier model units have differential screws.

**NOTE:** Install the stem and plate on the rocker cam input side. (9 o'clock position on "A" suffix, 3 o'clock on "B" suffix models) Refer to control location column of series model code.

**Piston and Shoe Assembly**

1. Install creep plate (5) over center post on rocker cam (22) with small O.D. of plate turned toward cam.
2. Insert the seven piston and shoes (4) in the shoe retainer (4). Position the assembly (4) over the center post and against the creep plate.
3. Install flange bearing (3) and thrust washer (2), over center post of cam and against shoe retainer.
4. Install the thickest retaining ring (1) with the dot up, that will fit in the groove on the rocker cam center post which will allow a maximum clearance of .002-.005" (.051-.127 mm) between the creep plate and shoe faces. There are five different retaining rings available for this tolerance. Each ring is marked; .101-.103" (2.56-2.62 mm) thick, blue dot; .103-.105" (2.62-2.67 mm) thick, red dot; .105-.107" (2.67-2.72 mm) thick, green dot; .107-.109 (2.72-2.77 mm) thick, yellow dot; .098-.100" (2.49-2.54mm) white dot.

The piston and shoe assembly (4) must be free to rotate easily by hand. The assembly must be rotated through 360° to confirm there is no binding and that each shoe is always free in the retainer plate. Oil the assembly thoroughly.

6. Position the cradle and cam assembly with the piston and shoe assembly attached with T marked on the cradle turned up.

## PARTS LIST FOR FIGURE 3

ITEM	DESCRIPTION	PART NO.	QTY.
1	Retaining Ring -Use one only		1
	(Yellow) .107-.109" (2.72-2.77 mm)	033-71556	
	(Green) .105-.107" (2.67-2.72 mm)	033-71557	
	(Red) .103-.105" (2.62-2.67 mm)	033-71558	
	(Blue) .101-.103" (2.56-2.62 mm)	033-71559	
	(White) .098-.100" (2.49-2.54 mm)	033-91231	
	Retaining Ring Service Kit	S23-12547	
2	Thrust washer	033-71565	1
3	Flange bearing	033-71563	1
4	Piston & shoe assy. w/retainer P11	S13-45544	1
	P14	S13-43970	
5	Creep plate	033-71569	1
6	Servo stem	033-71596	1
7	Orifice screw	033-20641	2 (P Units) 1 (V units)
8	Soc. head cap screw	359-09240	2
9	Soc. button head screw	353-25073	2
10	Servo plate	033-53874	1
11	Hex. head screw 1/2-13x3	306-40189	4
12	Soc. Setscrew	312-09032	2
13	Hex. head screw 3/8-16x2-3/4	306-40140	4
14R	Right side chamber cover CW Rotation	033-71598	1
	Right side chamber cover CCW Rotation	033-71595	
14L	Left side chamber cover CW Rotation	033-71597	1
	Left side chamber cover CCW Rotation	033-71593	
15	Dowel pin	324-22428	4
16	Control chamber	033-71615	2
17	Steel ball	201-06001	4
18	Control chamber seal	606-25040	2
19	Rocker cradle	033-57879	1
20	O-ring	691-00905	2
21	Hex. soc. plug	488-35020	2
22	Rocker cam	S23-12107	1
23	Vane holddown spring ( P,V units )	033-72233	12
24	Holddown vane	033-72234	4
25a	Vane seal backup plate	033-71608	4
25b	Vane seal	033-71611	2
25c	O-ring	691-00125	2
25d	Vane spacer	033-71607	2
25e	Check valve	033-70803	2
26	Override tube	033-71609	2

\*NOTE: Item 6 through 25 can be ordered as a complete Rocker Cam & Control Stroking Assembly.

**P Units**      **V Units**

S23-01354    S23-04200 is for RH (clockwise) pumps w/B suffix (input control on right hand side.)

S23-01355    S23-04203 is for LH (counter clockwise) pumps w/B suffix (input control on right hand side.)

S23-01352    S23-04201 is for RH (clockwise) pumps w/A suffix (input control on left hand side.)

S23-01353    S23-04202 is for LH (counter clockwise) pumps w/A suffix (input control on left hand side.)

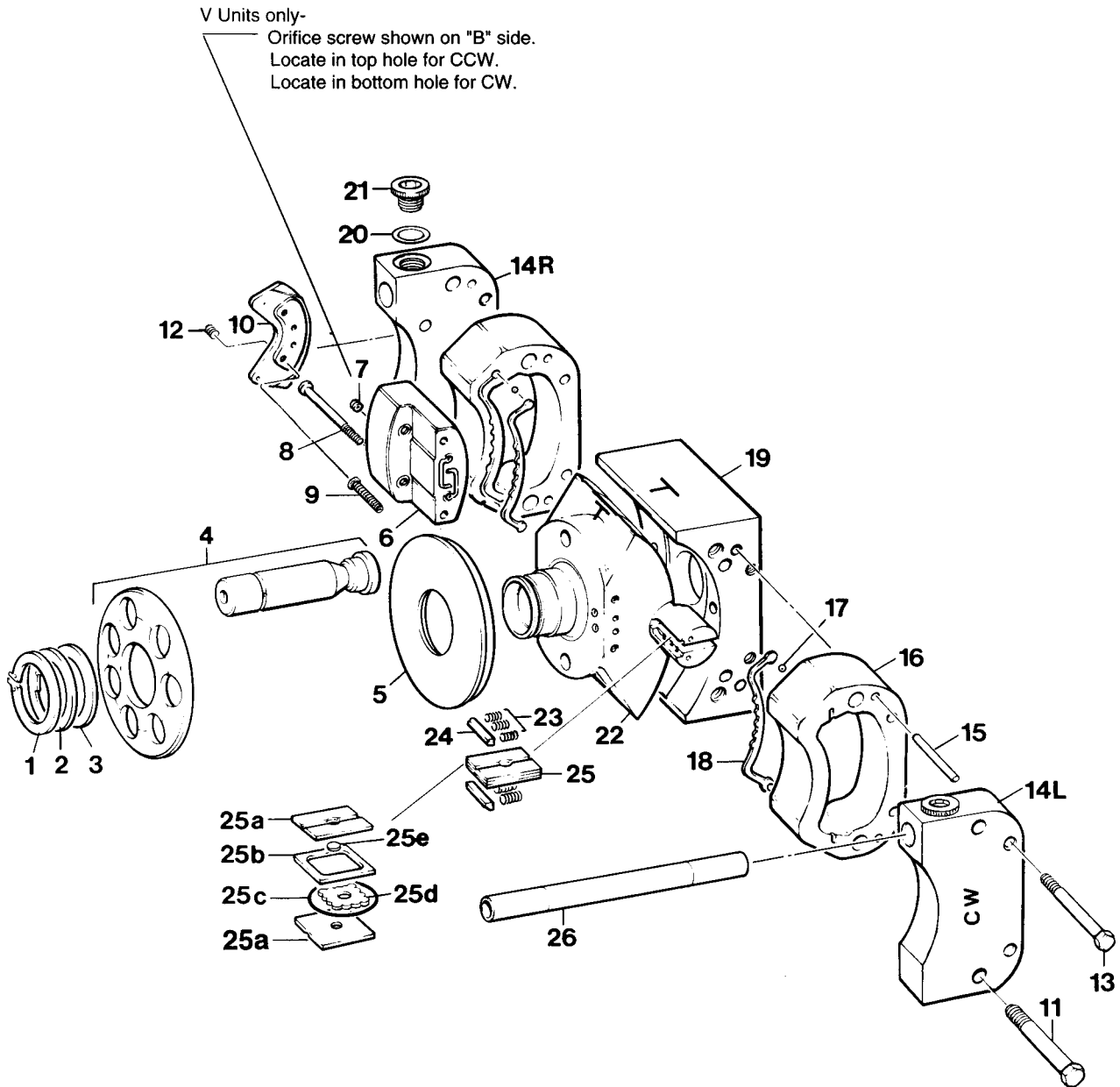

**FIGURE 3**  
**ROCKER CAM / PISTONS AND RETAINER**

**NOTE:** Install items 6, 7, 8, 9 and 10 on this side of rocker cam if pump model number has "B" suffix. Install on opposite side if "A" suffix.



SEE FIGURE 4

7. Install straight thread connectors (3) and O-rings (4) into threaded holes in cradle.
8. Install right and left hand pressure feed tubes (5 and 6) to connectors (3). Tighten connectors until snug.
9. Position the mounting flange (9) with the large open end up, and install two dowel pins (8) in the cradle mounting surface of the flange and four locating sleeves (10) in the outer edge of the flange.
10. Install rocker cam and cradle assembly over the two dowel pins (8) in the mounting flange. Be certain that cradle is seated over the pins.
11. Position the mounting flange with the rocker cam assembly installed on the side and install two 3/8-16 (9.5 mm) x 2 screws through the seal retainer area into the cradle. These screws are required to hold the rocker cam assembly in place and will be removed later.
12. Return the assembly to an upright position with the mounting flange down. Tilt the rocker cam to either extreme position in the cradle.
13. Position the Barrel Assembly with Auxiliary Shaft (1) directly over the pistons. Start with the uppermost piston and guide them one at a time into the barrel. Return the rocker cam to a level position in the cradle.

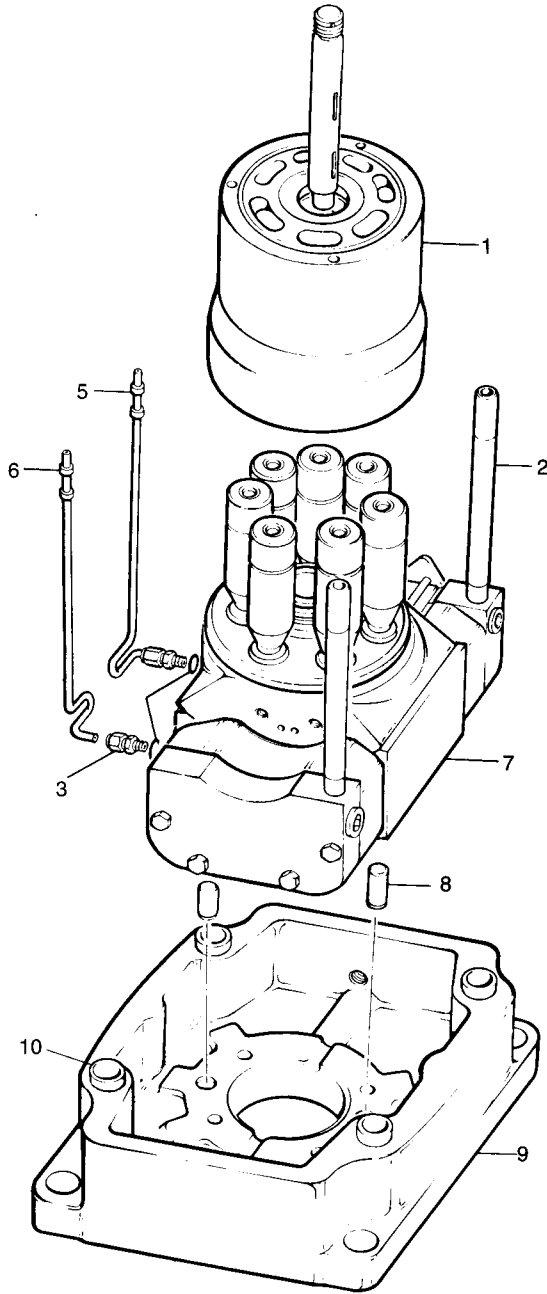

PARTS LIST FOR FIGURE 4

ITEM	DESCRIPTION	PART NO.	QTY.
1	Barrel and Auxiliary Shaft Assy.	See fig. 2	1
2	Override Pressure Tube	033-71609	2
3	Connector	492-15265	2
4	O-ring	691-00902	2
5	Tubing Assy. (right side)	S13-43967	1
6	Tubing Assy. (left side)	S13-43966	1
7	Rocker cam and Stroking Assy.	See fig. 3	1
8	Dowel Pin	324-23216	2
9	Mounting flange	033-71546	1
10	Locating sleeve	033-72664	4

PARTS LIST FOR FIGURE 5

ITEM	DESCRIPTION	PART NO.	QTY.
1	Housing	033-91191	1
2	Bearing	033-91190	1
3	Roll Pin	325-16320	2
4	Dowel Pin	324-21608	4
5	O-ring	691-00916	1
6	Hollow Hex Plug	488-35024	1
7	O-ring	691-00908	1
8	Retainer	033-91106	1

PARTS LIST FOR FIGURE 6

ITEM	DESCRIPTION	PART NO.	QTY.
1	Face Plate Pins	033-49825	3
*2	Barrel Face Plate 11 in <sup>3</sup> only	033-71921	1
	Barrel Face Plate 14 in <sup>3</sup> only	033-71575	
3	Housing Gasket	033-91076	1
4	Housing Assembly	See fig. 5	1

Item 2: (Ref. only) Arcuate port width: 11 in<sup>3</sup> is .469 in. (11.9 mm), 14 in<sup>3</sup> is .625 in. (15.9 mm).

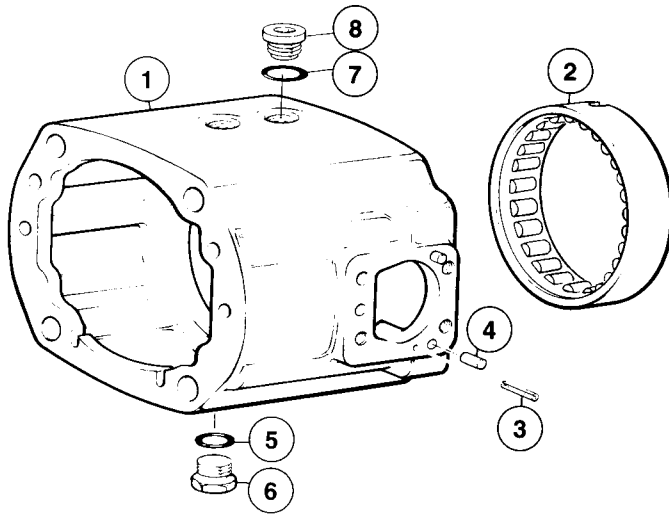

FIGURE 5

**S13-43962 Housing Assembly  
See Figure 5**

1. Wash and dry all parts. During assembly, lapped and ground surfaces should be kept lubricated with clear oil and protected from nicks or surface damage.
2. Clean housing, item #1, and barrel bearing, item #2. Apply loctite primer grade "T" & loctite retaining compound #609 to bearing O.D. & bearing bore of housing.
3. Rest housing on mounting flange end. Position notch on bearing (2) with hole in the housing bore. With smooth and steady force, immediately press the bearing into the housing bore until seated. **DO NOT HAMMER OR BEAT INTO PLACE.**
4. Install O-ring (6) and retainer (8) in housing.
5. Turn housing (1) on side and install roll pin (3) through hole in the control cover pad. The roll pin must be .375" (9.52 mm) below the pad surface. **THE PIN END MUST NOT INTERFERE WITH THE INTERNAL BEARING CAGE.** Install two dowel pins (4) in the blind holes in the same pad.
6. Repeat step 5 on the opposite side of the housing.
7. Place O-ring (5) on plug (6) and install in bottom of housing (1). (Roll pins (3) are in bottom of housing.)

**Assembly for Parts in Figure 6**

1. Insert the three face plate pins (1) in the holes provided in the barrel face.
2. Apply heavy grease to the face of the barrel and install the face plate (2) over the pins (1) in the barrel.

**Make certain the face plate is properly seated on the barrel and pins with the steel side towards the barrel face. The face plates have only one side bronzed and this should be toward the port plate. If necessary, remove coating from edge of face plate to determine bronze side.**

3. Install gasket (3) over the four locating sleeves (item 10 on Fig. 4) in the mounting flange.
4. Position the Housing Assembly (4) over the Barrel and Auxiliary Shaft Assembly and carefully guide the override tubes and pressure feed tubes (items 2, 5 and 6 on Fig. 4) through the Housing Assembly. Position the pressure feed tubes in the slots in the housing face.

FIGURE 6

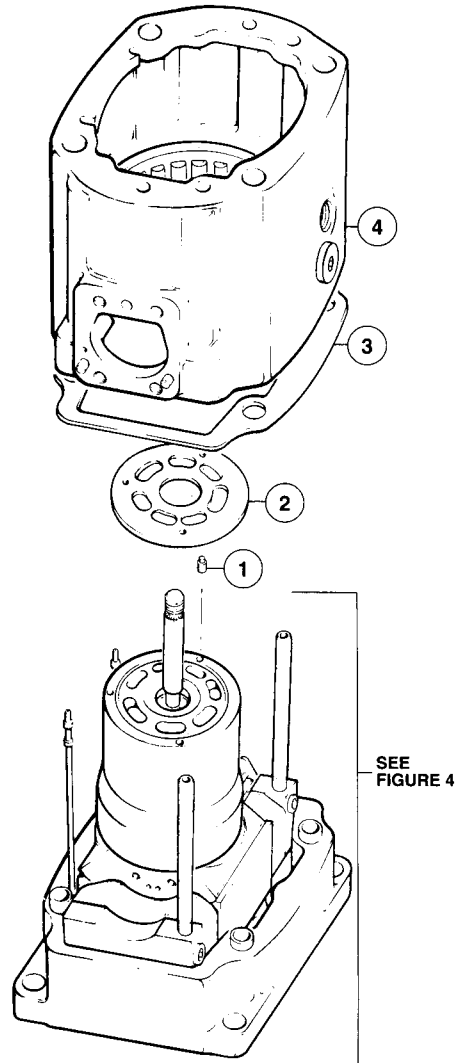

SEE FIGURE 4

**S13-44138 Port Block Assembly Figure 7**

1. Position the port block (1) on a clean flat surface with the two open ports up. THE OPPOSITE FACE MUST NOT BE SCRATCHED OR DAMAGED. Position needle bearing (2) on tool (Figure T-1) with the marked end of the bearing against the shoulder on the tool and press the bearing (2) into the port block. The bearing must be .010-.025 (.25-.64 mm) below the surface.
2. Slip ring check (3) into the two system ports and align holes in the ring with the side holes in the port wall.
3. Place lock washers (5) on special screws (4). Insert (4) through port wall and drilled holes in checks (3) and thread into clamps (6). Torque to 10 ft. lbs. (13.56 Nm). Use solid rings on open loop pumps.
4. Thread two check valve assemblies (7) into valve face of port block.
5. Install hex socket plugs (8) and O-rings (9) into port block.
6. Install four hex socket plug (10) and O-rings (11) into port block. Install hex plug (12) and O-ring (13) into port block.

**Mounting Port Block Assembly Figure 8**

Position the pump with the unplugged hole in the housing assembly (6) at 12 o'clock position.

Install gasket (5) on the housing assembly.

Install the two special pins (3) in the face of the port block assembly. Apply petroleum jelly or heavy grease to the plate (4) and position port plate over the pins (3) on the port block. Port plate must be fully seated and indexed with direction of rotation. Slide the port block assembly and port plate over the end of the auxiliary shaft. Be certain that tubes 2, 5 and 6 shown on Fig. 4 are fully seated and that the port plate (4) remains firmly secured on the pins.

When the pump is properly assembled, the valve mounting surface will be at the top of the unit.

Install the four bolts (1) with washers (7). Do not drop the bolts in place as the threads may be damaged. Torque bolts evenly in 50 ft.-lb.(68 N•m) increments to 350 ft.-lbs.(475 N•m) total.

**CAUTION:** Use care to prevent damage to the valve mounting surface while installing and torquing the two top bolts.

**Port Block Assembly (Fig. 7)**

ITEM	DESCRIPTION	PART NO.	QTY.
1	Port block (P units)	033-57912	1
	Port block (V units)	033-91194	1
2	Needle bearing	230-82146	1
3	Check ring (P units)	033-70502	2
	Check ring solid (V only, not shown)	033-71411 033-57324	1 each
4*	Special screw (P units)	033-70908	2
5*	No. 10 Lock washer (P units)	348-10016	2
6*	Clamp (P units)	033-70489	2
7	Check valve assy. (P units)	S13-40266	2
	Screw-socket set (V units) on B port	353-25037	1
8	Hex socket plug	488-35041	6
9	O-ring 90-6290-6	691-00906	6
10	Hex socket plug	488-35001	4
11	O-ring	691-00904	4
12	Hex socket plug (P units)	488-35055	1
13	O-ring (P Units)	691-00910	1
14	O-ring (1 Req.'d on V units)	691-00908	2
15	Hex socket plug (1 Req.'d on V units)	488-35018	2

**Port Block Assembly (Fig. 8)**

ITEM	DESCRIPTION	PART NO.	QTY.
1	Hex head cap screw	306-40172	4
2	Port block Assy. (P units)	S13-44138	1
	Port block Assy. (V units)	S23-12635	1
3	Port plate pins	324-21610	2
4	RH port plate 11 in <sup>3</sup> (P units)	033-71915	1
	RH port plate 11 in <sup>3</sup> (V units)	033-91195	1
	LH port plate 11 in <sup>3</sup> (P units)	033-71914	1
	LH port plate 11 in <sup>3</sup> (V units)	033-91224	1
	RH port plate 14 in <sup>3</sup> (P units)	033-71617	1
	RH port plate 14 in <sup>3</sup> (V units)	033-91241	1
	LH port plate 14 in <sup>3</sup> (P units)	033-71600	1
	LH port plate 14 in <sup>3</sup> (V units)	033-91242	1
5	Port block gasket	033-91079	1
6	Housing Assy.	S13-43962	1
7	Washer	350-10109	4

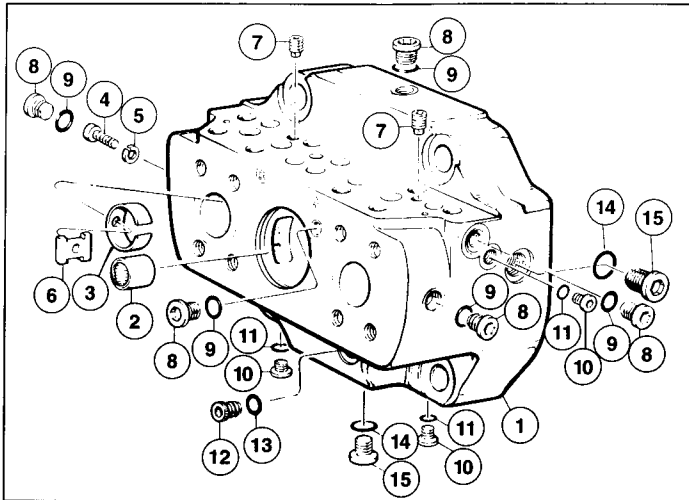
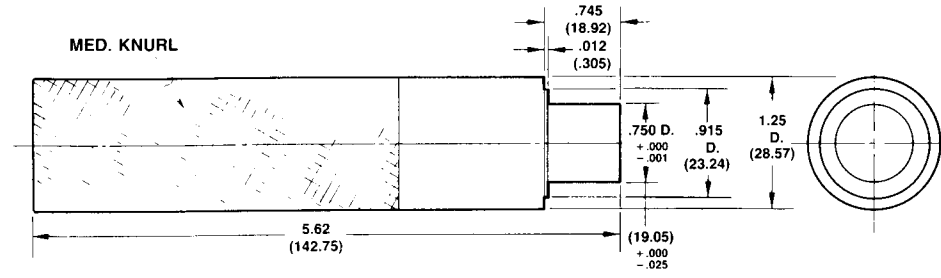

FIGURE 7



T-1

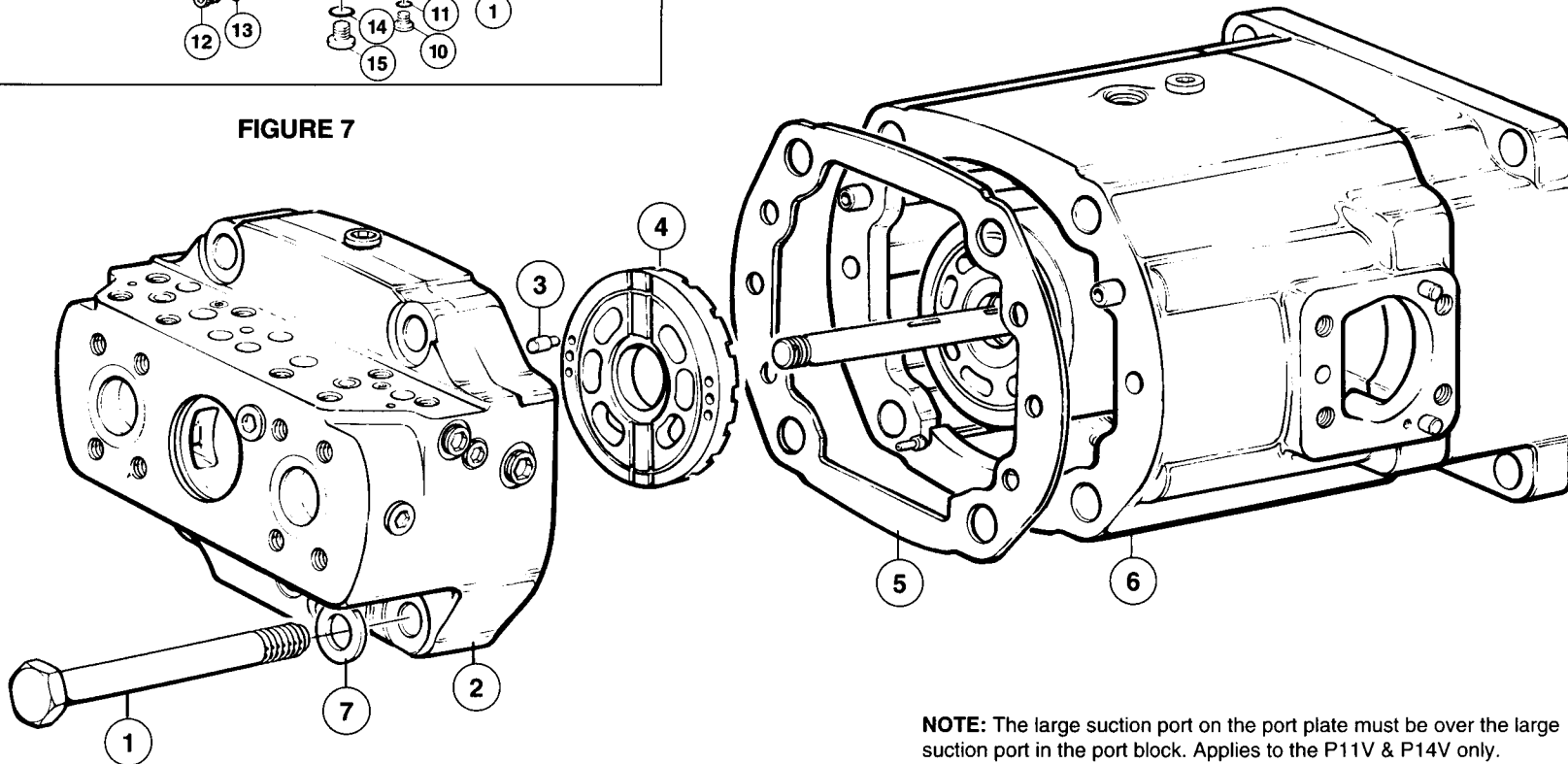

FIGURE 8

NOTE: The large suction port on the port plate must be over the large suction port in the port block. Applies to the P11V & P14V only.

**Gerotor and Barrel Holddown  
Figure 9**

1. Position the unit with the shaft in a horizontal position and the valve block mounting surface turned up. **Facing the port block end of the unit**, rotate the shaft until the small keyway in the auxiliary shaft is at 12 o'clock.
2. If pump is being assembled for right hand rotation install dowel pin (8) in hole in port block at the 9 o'clock position; if left hand pump, install at 3 o'clock position.
3. Install side plate (1), steel side first, over dowel pin. Insert key (2) in rear keyway on auxiliary shaft.
4. Install the inner gear (c) of the replenishing gerotor assembly on the auxiliary shaft and over the key. Install the eccentric ring (a) on the dowel pin (8). Install the large outer gear of the gerotor assembly (b) inside the eccentric ring and over the inner gear.
5. Install center port plate (4) over the auxiliary shaft, engaging the dowel pin (8). The suction area of the port plate must be located at the bottom of the unit.
6. Install key (6) in remaining auxiliary shaft keyway.
7. Repeat steps 4 for servo gerotor assembly (7).

8. Place O-rings (10) and (11) on side plate assembly (9). Lubricate the O-rings and slip the pressure plate (12) over the O-rings on the side plate assembly. Install the assembled plates over the auxiliary shaft engaging the dowel pin (8).

9. Place seal ring (15) on auxiliary shaft. Position bearing (14) between the two thrust washers (13) and install around the seal ring. Thread holddown nut (16) on the shaft and tighten no more than 10 ft.-lbs. (13.56 N•m) max. Back off the nut (16) until second slot is aligned with pin hole in the shaft. Insert cotter pin (17) through nut and shaft. Bend one tang over end of shaft.

Check the main shaft for smooth rotation. If not smooth, check the gerotor parts for position and holddown nut for proper adjustment.

11. Place O-ring (21) on hex plug (22) and install in end cover (18).

12. Place O-ring (19) on end cover (18) and lubricate. Place end cover over holddown nut (13). Depress cover and install snap ring (20). Make certain that snap ring is properly seated in groove.

**NOTE:** When changing pump rotation consult parts list for proper side plate.

**Parts List for Figure 9**

ITEM	DESCRIPTION	PART NO.	QTY.
1	Side plate	033-71619	1
2	Square key 1/8 x 9/16	211-22034	1
3	Replenishing Gerotor assy. (Closed loop only)	S13-43334	1
3a	Gerotor plug (V units only) Replaces #3	033-72620	1
4	Center port plate	S13-43963	1
5	Not used		
6	Key	211-22034	1
7	Servo Gerotor assy	S13-43334	1
8	Dowel pin	033-71620	1
9	Side plate & Bearing assy	*	1
10	O-ring	671-00144	1
11	O-ring	671-00129	1
12	Pressure plate	033-70531	1
13	Thrust washer	350-10081	2
14	Thrust bearing	230-82164	1
15	Seal ring	033-72101	1
16	Holddown nut	033-72026	1
17	Cotter pin	322-04324	1
18	End cover	033-72100	1
19	O-ring	671-00147	1
20	Internal snap ring Eaton IN287	356-65082	1
21	O-ring	691-00916	1
22	Plug	488-35024	1

\* For RH pumps use S13-46762  
For LH pumps use S13-46763



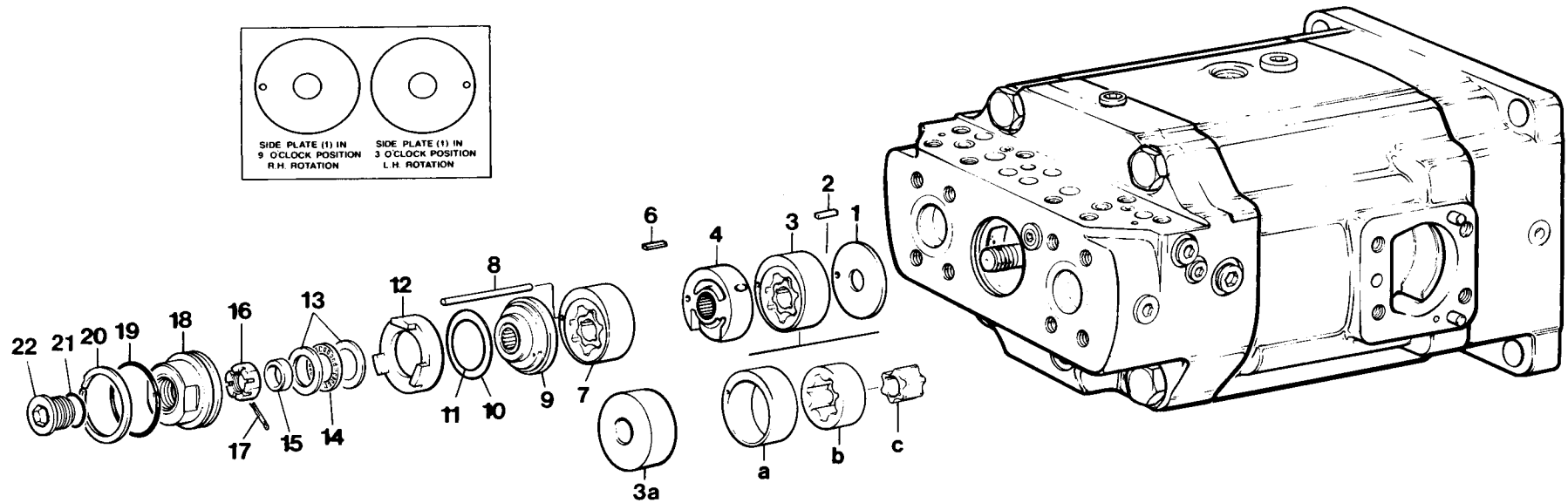

FIGURE 9

**Valve Block Assembly (Before 7-93)  
Figure 10**

**Note:** Prior to assembly of reconditioned parts, check finish of gasket on valve block and retainer. Must have 60 rms with no grinding marks which might carry oil to outside surface. If lapping is necessary, check depth of pockets for valve seats after lapping. Must be .085" (2.16 mm) minimum after lapping, to provide clearance for valve seats.

Lubricate the four orifice plugs (12) and insert in the top of valve block (11).

Check the pilot valve assembly (41) to be certain that approximately 1-1/2 threads are exposed from this small nut on the bottom of the valve assembly. This setting will allow the valve to function at about 100 PSI (6.8 bar). Each complete right hand turn of this screw will increase the pressure about 25 PSI (1.7 bar). Torque hex lock nut to 20-25 in. lbs. (2.26 to 2.82 N•m). Thread the check valve (41) into the 3/8-24 tapped hole into the valve block (11) as shown. (V) units do not receive the valve assembly.

Press the two dowel pins (10) into the holes provided in the bottom of the valve block (11). The pins (10) must be .12" (.3 mm) below the surface.

Place the two sequence seats (8) in the sequence ports (SB, SA). Place the four valve seats (9) in the ports marked RB, RA, RV and servo. Servo and RV seats to be inserted with grooved side down. Position the gasket (7) and retainer plate (6) over the seats and insert the four screws (4) in the block (11). Torque to 10 in.lbs. (1.1 N•m)

**Note:** There is no replenish seat for V units.

Position the valve block and the attached parts with four orifices (12) turned up. Insert the two 1-7/16 long springs (17) in the two sequence poppets (13) and install (13) and (17) in the block and over the sequence seats (18) in ports SB and SA. Install the four valve poppets (14) in the ports marked RB, RA, RV and servo. Insert spring retainer (15), large end first, in the servo poppet. Insert the light weight spring (18) 1/2" long in the RV poppet. Insert the three 1" long springs (16) in poppets RB, RA and servo.

Lubricate the two check valves (19) and install in sides of cover (21).

Lubricate O-ring (22) and place on seat (23) and install in valve cover (21). Use a 1/2" 6 point 1/4" drive socket and torque to 15 ft.-lbs. (20.4 N•m). Do not use impact wrench. Lubricate O-rings (26) and (28) and place on parts (27) and (29). Assemble parts 30, and 33 on (31) and start (31) into housing (29). Push seal piston (27) and O-ring (26) into housing (29) with the small end of the piston exposed. Place spring (25) on cone (24) and insert all these parts in the valve cover (21). Be certain that cone (24) enters seat (23).

Remove the 8-32 nut from strainer assembly (34). Insert the strainer assembly in the largest hole in cover (21). Push the 8-32 threads thru the small drilled hole in bottom and attach the 8-32 nut under the cover. Lubricate O-rings (37). Install (37) in the block (11).

Position the cover (21) over the springs and poppets and install the four screws (39). **BE CERTAIN THAT THE SPRINGS ARE IN THE RIGHT POSITION BEFORE TIGHTENING THE SCREWS.**

Install dowel pin or roller pin (40) in the hole over the servo poppet. Lubricate the four O-rings (42) and place on the four plugs (43). Install the four plugs. Lubricate O-ring (35) and place on plug (36) and install.

**CAUTION:** Use of other than SAE plugs will result in malfunction and possible pump damage

Invert the complete assembly and install roll pins (5) thru plate (6) and into the valve block. Install O-rings 2 and 3 in the plate (6).

**PARTS LIST FOR FIGURE 10**

ITEM	DESCRIPTION	PART NO.	QTY.
1	Not used		
2	O-ring 70-914-2	671-00014	2
3	O-ring 70-914-1	671-00013	2
4	10-24 x 1/2 Button hd screw	353-25023	4
5	1/8 x 3/4 Roll pin	325-08120	2
6	Retainer plate	033-91422	1
7	Lower gasket	033-91193	1
8	Sequence seat	033-70507	2
9	Valve seat (qty. 3 in PV only)	033-70500	4
10	3/16 x 3/4 Roll pin	325-12120	2
11	Valve block	033-72377	1
12	.047 Orifice plug	033-25528	4
13	Sequence poppet	033-72378	2
14	Valve poppet (qty. 3 in PV only)	033-72379	4
15	Spring retainer	033-70482	1
16	Spring (1 OAL)	033-71086	3
17	Spring (1-7/16 OAL)	033-70512	2
18	Spring (light weight) (P units)	033-22141	1
19	Check valve assy.	S13-40266	2
20	Not used		
21	Valve cover (P units)	033-72376	1
	Valve cover ( V units)	033-72676	
22	O-ring 6290-3	691-00903	1
23	Seat	033-70508	1
24	Cone	033-12288	1
25	Spring	033-12289	1
26	O-ring 70-6227-7	671-00012	1
27	Seal piston	033-21767	1
28	O-ring 90-6290-10	691-00910	1
29	Housing	033-70545	1
30	5/16-24 Hex nut	335-13100	1
31	5/16-24 x 1-1/2 Soc set screw	312-13160	1
32	Not used		
33	Acorn nut	327-25006	1
34	Servo strainer assy.	S13-43240	1
35	O-ring 90-6290-6	691-00906	1
36	Hex plug SAE-6	488-35003	1
37	O-ring	671-00050	2
38	Not used		
39	Hex hd cap screw 10-24 x 1-3/4	306-40167	4
40	Roller ( V units)	230-82170	1
	Dowel pin 1/8 x 5/8 (P units)	324-20810	
41	Pilot relief assy (P units)	S23-12699	1
42	O-ring 90-6290-4	691-00904	5
43	Hollow hex plug SAE-4	488-35001	5

Seal Kit **S23-00135-0**  
**S23-00135-4**  
**S23-00135-5**

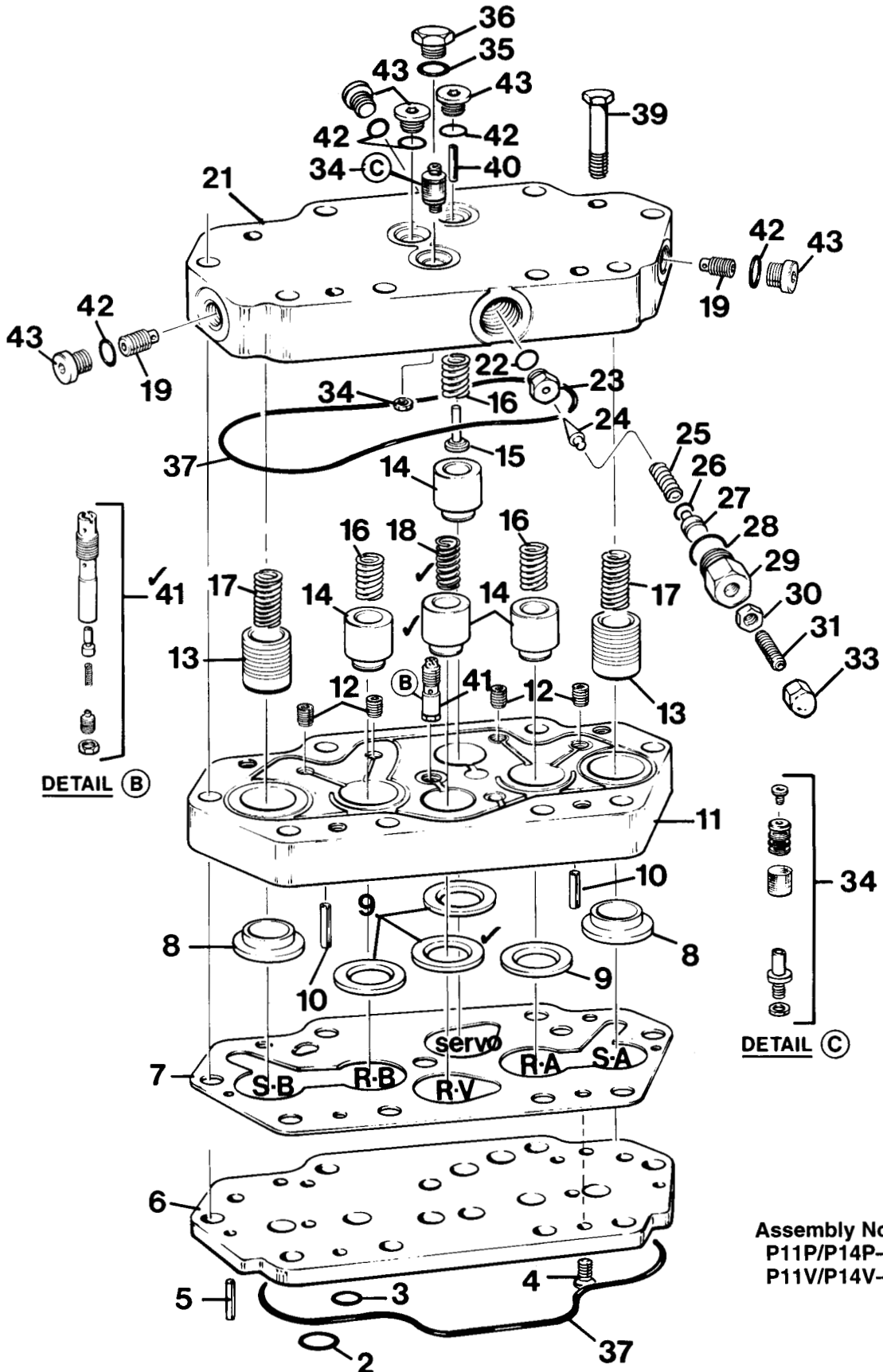

Assembly No.  
 P11P/P14P—S23-11425  
 P11V/P14V—S13-48989

FIGURE 10 VALVE BLOCK ASSEMBLY  
 (Before 7-93)

### Valve Block Assembly (After 7-93) See Figure 11

**NOTE:** Do not use impact tools or over tighten threaded parts.

1. Wash and dry all parts. During assembly, lapped and ground surfaces should be kept lubricated with clean oil and protected from nicks or surface damage.
2. Place valve block (1) with the six poppet valves bores up. In order to press two roll pins (46) in position. (Roll pins to be .12" (3.04 mm) below surface of valve block.)
3. Install four orifice plugs (3) into valve block (1) and tighten in place.
4. Disassemble the strainer assembly (14) and reassemble per the following steps:
  - a. Install the orifice screw of the strainer assembly into valve block. Thread elastic stop nut onto the orifice screw and **torque to 23 in.-lb. (2.6 N•m).**
  - b. Install clean filter screen on strainer support and secure in place with socket head cap screw, 6-32 x 1/4" long. **Torque 6-32 screw to 13 in.-lb. (1.47 N•m).**
5. Place valve block with poppet valve bores facing up. Position gasket (29) on valve block.
6. Place springs (33), 1.43" (36.32 mm) into outer most bores at each end of the valve block. Place sequence poppets (30) over these springs. Position seats (27) small shoulder side first over poppets.
7. Place springs (35), 1.09" (27.68 mm) into bores next to the sequence poppet valves of step 5. Place dual relief poppet (31) over these springs. Position seats (28) with the groove side facing up, over poppets.
8. Place spring (32) into bore next to compensator valve side of block. Install replenish poppet over spring. Position seat (28) with the groove side facing down, over poppet. (Not used in V units.)
9. Insert spring (35) into the remaining bore. Place spring retainer (34) in spring. Place servo poppet (31) over the retainer and spring. Position seat (28) with the groove side facing down, over poppet.
10. Carefully position the retainer plate over seats and poppets. Pressing with one hand on the valve block, compress seats, poppets and springs far enough to alternately thread two button head cap screws (43) in far enough to hold the retainer plate. Install the other two screws and alternately tighten screws. Torque to 30 in.-lb. (3.39 N•m)
11. Lubricate O-ring (4) and install on to seat (5), thread seat in valve block. (Be careful not to damage bore in the seat.) Torque to 15 lb-ft (20.34 N•m).
12. Apply vaseline to shank of cone (13) and install spring (12) on cone. Carefully insert cone and spring into valve block positioning point of cone into bore of seat.
13. Lubricate O-ring (11) install in groove of piston (10) and insert end of piston into spring (12).
14. Lubricate O-ring (9) and install on housing guide (8) and thread into valve block. Tighten in place.
15. Thread nut (7) on socket set screw (6) and thread screw into housing guide (8) until it starts to compress spring.
16. Using a small bladed screw driver, thread the pilot replenishing relief valve assembly (36) into valve block and lightly tighten in place. (Do not over tighten. Overtightening can cause sides of slot to break now or at next removal.)
17. Lubricate O-ring (4) and install on plug (25) and tighten plug in place.
18. Thread check valve (2) into valve block and lightly tighten in place. (Do not over tighten.) Lubricate O-ring (22) and install on plug (23) and tighten in place.
19. Repeat step 19., on other end of valve block.
20. Lubricate O-ring (19) and install on plug (20) and tighten plug in place.
21. Install pin (21). Lubricate O-ring (22) and install over plug (23) and tighten plug in place.
22. Lubricate O-ring (4) and install on plug (25) and tighten in place.
23. Lubricate two O-rings (22) and install over two plugs (25) and tighten in place.
24. Using a small hammer carefully tap roll pins (46) into and thru the retainer plate (42), the pins should bottom out in hole leaving enough length sticking out for piloting into the port block.
25. Lubricate O-ring (47), (48) and (37) and install in the bottom of retainer plate (42).

Valve is ready to install on pump.

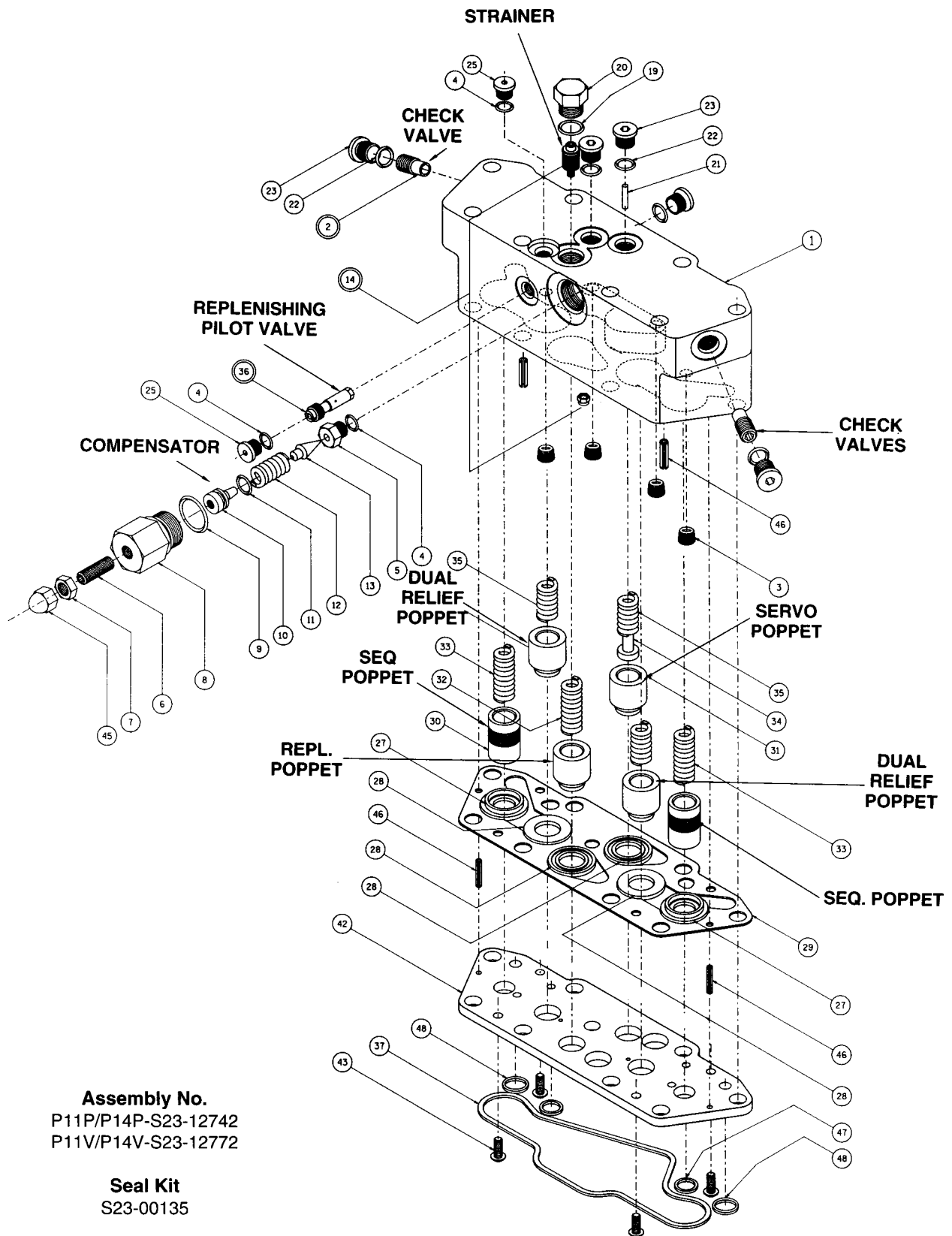

**FIGURE 11**  
(AFTER 7-93) VALVE BLOCK ASSEMBLY



**PARTS LIST FOR FIGURE 11**

ITEM	DESCRIPTION	PART NO.	QTY.
1	Valve block (P Units)	033-91221	1
	Valve Block (V Units)	033-91334	
2	Check Valve	S13-40266	2
3	Orifice plug (.0465 dia.)		
	(1.18mm)	033-91249	4
4	Gasket, O-ring	691-00903	3
5	Seat	033-70508	1
6	Screw, socket head 5/16 – 24 x 1	312-13160	1
7	Nut, hex jam 5/16 – 24	335-13100	1
8	Housing guide	033-70545	1
9	Gasket, O-ring	691-00910	1
10	Piston	033-21767	1
11	Gasket, O-ring	671-00012	1
12	Spring	036-12289	1
13	Cone	036-12288	1
14	Assy servo strainer	S13-43240	1
19	Gasket, O-ring	691-00906	1
20	Plug	488-35003	1
21	Pin, 1/8 x 5/8 (P Units)	324-20810	1
	Roller (V Units)	230-82170	
22	Gasket, O-ring	691-00904	5
23	Plug	488-35001	5
25	Plug	488-35049	2
26	Pin, roll 3/16 x 3/4	325-12120	2
27	Seat, sequence	033-70507	2
28	Replenish & servo seat	033-70500	4
	(Qty. 3 in PV only)		
29	Gasket, valve block	033-91193	1
30	Poppet, sequence	033-72378	2
31	Poppet, dual & replenish	033-72379	4
	(Qty. 3 in PV only)		
32	Spring, replenish (P Units)	033-22141	1
33	Spring, sequence & servo	033-70512	2
34	Spring retainer	033-70482	1
35	Spring, dual relief	033-71086	3
36	Pilot valve, replenish relief (P Units)	S23-12699	1
37	Gasket, O-ring	671-00050	1
42	Retainer plate	033-91422	1
43	Screw, button head		
	#10-24 x 3/4 LG	353-25078	4
45	Nut, acorn 5/16 – 24	327-25006	1
46	Pin, roll 1/8 x 3/4	325-08120	2
47	Gasket, O-ring	671-00013	2
48	Gasket, O-ring	671-00014	2

## PARTS LIST FOR FIGURE 12

ITEM	DESCRIPTION	PART NO.	QTY.
1	Valve Cover	033-54391	1
2	Valve check	S13-40266	2
3	Orifice #56 (.0465) 1/16 pt	033-25528	5
4	O-ring, 90 S-1 ARP 903	691-00903	1
5	Seat	033-70508	1
6	Set Screw, 5/16-24 x 1 cup pt	312-13160	1
7	Hex jam nut	335-13100	1
8	Guide-housing	033-70545	1
9	O-ring, 90 S-1 ARP 910	691-00910	1
10	Piston	033-21767	1
11	O-ring, 70 S-1 ARP 012	671-00012	1
12	Spring	036-12289	1
13	Cone	036-12288	1
14	Servo strainer	S13-43240	1
15	Manifold	033-54389	1
16	Spring (Lee #LC-038C-19)	225-92083	1
19	O-ring, 90 S-1 ARP 906	691-00906	3
20	Plug 6HP5N- PL	488-35041	3
21	Gasket	035-47851	1
22	O-ring, 90 S-1 ARP 904	691-00904	10
23	Plug, 4HP5N-S w/o PL	488-35001	9
25	Valve Block	033-54390	2
26	Roll pin 3/16 x 3/4	325-12120	2
27	Seat Sys Relief	033-70507	2
28	Servo Seat	033-70500	3
29	Gasket	033-91193	1
30	Poppet	033-72378	2
31	Poppet	033-72379	3
32	Spring	033-22141	1
33	Spring	033-70512	3
34	Poppet, Servo relief	033-54398	1
35	Spring	033-71086	2
36	Valve, Repl pilot	S23-12699	1
37	O-ring, 70 S-1 ARP 050	671-00050	1
38	Spool	033-54392	1
39	O-ring, 90 S-1 ARP 008	691-00008	1
41	Screw, Soc Hd 10-24 x 2-3/4	358-10300	4
42	Retainer plate	033-91422	1
43	Screw	353-25023	4
44	Seat, Servo relief	033-54399	1
45	Acorn nut	327-25006	1
46	Rollpin 1/8 x 3/4	325-08120	2
47	O-ring, 70 S-1 ARP 013	671-00013	6
48	O-ring, 70 S-1 ARP 014	671-00014	2
49	Plug 3/4-16	449-00016	2
50	Plug 7/16-20	449-00013	1
51	Cover, gasket	035-47852	1
52	Screw, Soc Hd 10-32 x 1/2	359-09080	4
53	Screw, Soc Hd 3/8-16 x 4	358-16360	4
54	Plug	035-54400	1
55	Screw, Hex Hd	306-40132	4

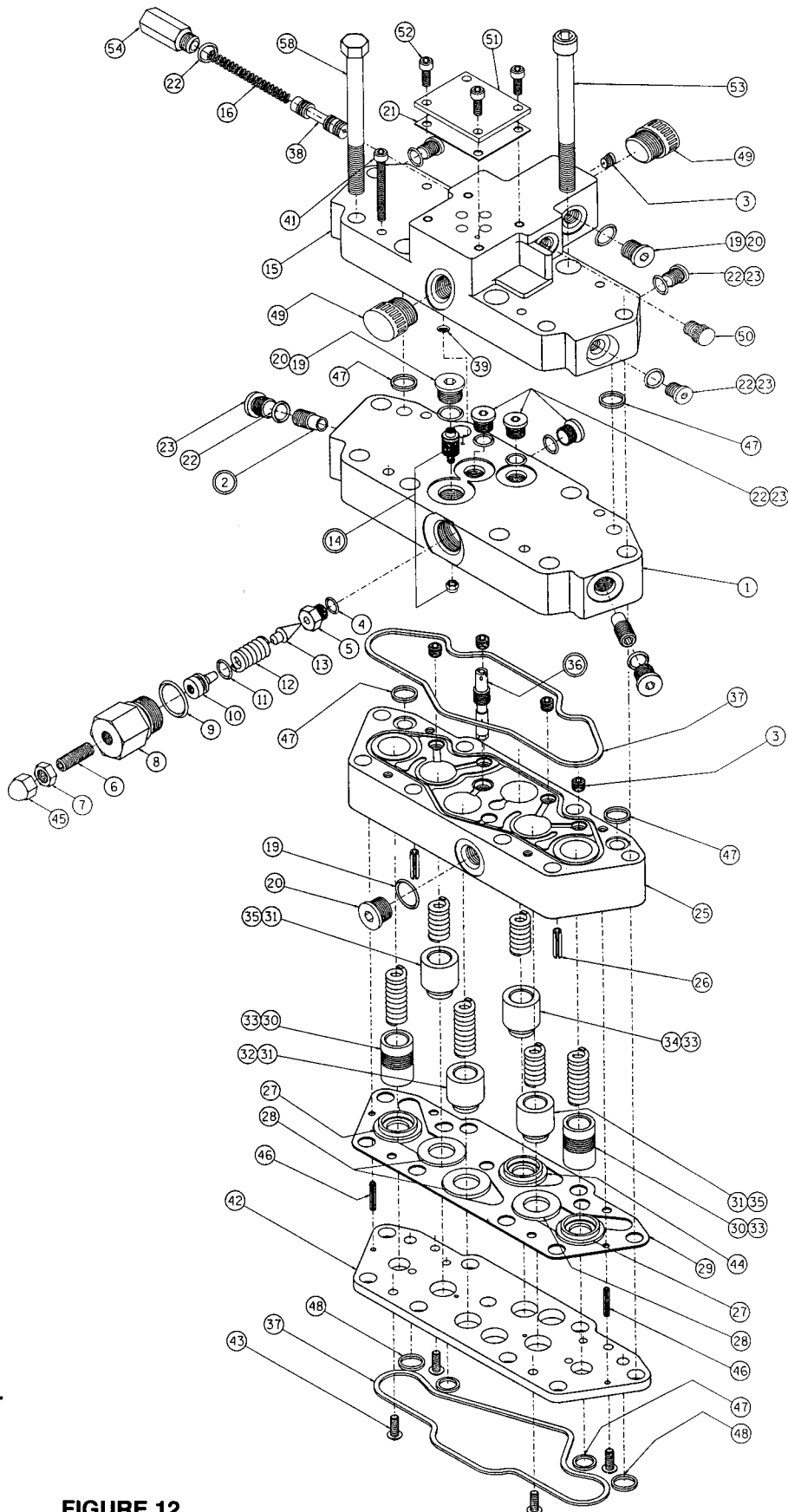

ASSEMBLY No.  
S23-11433

FIGURE 12  
VALVE BLOCK ASSEMBLY FOR SERVO VALVE MTG. (Before 7-93)

**Valve Block Assembly for Special Mounting of Servo Valve (Before 7-93)  
See Figure 12**

**Note:** Prior to assembly of reconditioned parts, check finish of gasket surface on valve block and retainer. Must have 60 rms finish with no grinding marks which might carry oil to outside surface. If lapping is necessary, check depth of pockets for valve seats after lapping. Must be .085" (2.16 mm) minimum after lapping, to provide clearance for valve seats.

1. Wash and dry all parts. During assembly, lapped and ground surfaces should be kept lubricated with clean oil and protected from nicks or surface damage.
2. Place valve block (25) with O-ring groove down and horizontal in order to press two roll pins (26) in position. (Roll pins to be .12" (3.05 mm) below surface of valve block.)
3. Apply a liberal amount of vaseline or grease to the six counterbores in the face of the valve block (25). Install two valve seats (27) tapered bore side first, into counterbores and against roll pin (26), one required each end, (outer-most counterbores in block). Insert three valve seats (28) and valve seat (44) in remaining counterbores as shown. Seat for RV port to have grooved side down.
4. Press two roll pins (46) into retainer plate (42). Each roll pin should stick out approximately .25" (6.35 mm) from each face of the retainer plate.
5. Position valve block gasket (29) on valve block. Take care that none of the gasket is covering the valve seats.
  - a. Position retainer plate (42) with O-ring grooves facing up, over valve block gasket. Install four button-head cap screws (43), torque to 30 in. lbs. (3.39 N•m).
  - b. Turn the assembly over so that it is resting with the retainer plate O-ring side downward.
6. Place spring (33) (1.43" long) (36.3 mm) into poppet (30) and insert small hole end first into outer-most bores at each end of the valve block (25).
7. Insert three poppets (31) and one poppet (34) in remaining bores as shown, small diameter end first.
8. Slip springs (33) into poppets (34) and (30) as shown.
9. Insert two springs (35) (1.09" long) (27.7 mm) into remaining outer poppets (31).
10. Install spring (32) into remaining poppet located in center of valve block.
11. Install four orifice plugs (3) in valve block (25) and tighten in place.
12. Thread pilot replenishing relief valve (36) into valve block (25). Valve must not extend below lower surface of retainer plate.
13. Place O-ring (37) and two (2) O-rings (47) into the

grooves on the upper surface of the valve block and secure with vaseline or grease.

14. Place O-ring (4) onto seat (5) and install in valve block cover (1). (Be careful not to damage bore in seat.) Torque (5) to 15 ft. lbs. (20.4 N•m). (Do not use impact wrench).
15. Lubricate O-ring (11) and insert into groove of seal piston (10) and slip spring (12) onto end of seal piston and press into bore of housing guide (8).
  - a. Lubricate O-ring (9) and install on housing guide (8).
  - b. Place shank of cone (13) into spring (12).
  - c. Align cone with seat in valve cover and thread housing guide into bore and tighten in place.
16. Thread nut (7) on soc. setscrew (6) and thread into housing guide (8) until it starts to compress spring. Thread acorn nut (45) on soc. setscrew (6).
17. Coat check valve (2) threads with loctite removable thread locker #242 and thread into end of valve cover (1). (Be sure check valve is properly installed and does not block passages from orifice plug (3). Lubricate O-ring (22) and install on plug (23) and tighten.
18. Repeat step 17 at the opposite end of the valve cover (1).
19. Disassemble the strainer assembly (14) in valve block and reassemble per the following:
  - a. Install the orifice screw (2) of strainer assembly (14) into valve cover. Thread elastic stop nut (1) onto the orifice screw and torque to 23 in. lbs. (2.6 N•m).
  - b. Install the strainer support (4), filter screen (6) and 6-32 x 1/4 lg. screw (5). Torque 6-32 screw (5) to 13 in. lbs. (1.47 N•m).
20. Place valve cover (1) over valve block (25) positioning over springs (33), (32) and (35) and secure in place with four (4) socket hd. cap screws (41).
21. Lubricate O-ring (22) and install on plug (23) and tighten in place.
22. Lubricate O-ring (19) and install over plug (20) and tighten plug in place.
23. Lubricate O-rings (47) and install in underside of manifold block (15). Carefully, place manifold block (15) on top of the valve cover (1) making sure the O-rings are correctly seated. Secure with four (4) soc. hd. cap screws (41) by threading into valve block (25).
24. Insert spring (16) and spool (38) into manifold (15) with the spring guide and spring towards the left side of the manifold (15) when viewing from the top rear.
25. Install temporary plugs (49) and (50) in 1/2" tube and 1/4" tube ports, front and back and side. Insert O-ring (19) and plug (20) in alternate drain port.



**Valve Block Assembly For Special Mounting of ServoValve (After 7-93) See Figure 13**

**NOTE:** Do not use impact tools or over tighten threaded parts.

1. Wash and dry all parts. During assembly, lapped and ground surfaces should be kept lubricated with clean oil and protected from nicks or surface damage.
2. Place valve block (1) with the six poppet valves bores up. In order to press two roll pins (46) in position. (Roll pins to be .12" (3.04 mm) below surface of valve block.)
3. Install four orifice plugs (3) into valve block (1) and tighten in place.
4. Disassemble the strainer assembly (14) and reassemble per the following steps:
  - a. Install the orifice screw of the strainer assembly into valve block. Thread elastic stop nut onto the orifice screw and **torque to 23 lb-in. (2.6 N•m)**.
  - b. Install clean filter screen on strainer support and secure in place with socket head cap screw, 6-32 x 1/4" long. **Torque 6-32 screw to 13 lb-in (1.47 N•m)**.
5. Place valve block with poppet valve bores facing up. Position gasket (29) on valve block.
6. Place springs (33), 1.43" (36.32 mm) into outer most bores at each end of the valve block. Place sequence poppets (30) over these springs. Position seats (27) small shoulder side first over poppets.
7. Place springs (35), 1.09" (27.68 mm) into bores next to the sequence poppet valves of step 5. Place dual relief poppet (31) over these springs. Position seats (28) with the groove side facing up, over poppets.
8. Place spring (32) into bore next to compensator valve side of block. Install replenish poppet over spring. Position seat (28) with the groove side facing down, over poppet. (Not used in V units.)
9. Insert spring (33) into the remaining bore. Place servo poppet (34) over the retainer and spring. Position seat (44) with the tapered bore facing down, over poppet.
10. Carefully position the retainer plate over seats and poppets. Pressing with one hand on the valve block, compress seats, poppets and springs far enough to alternately thread two button head cap screws (43) in far enough to hold the retainer plate. Install the other two screws and alternately tighten screws. Torque to 30 lb-in. (3.39 N•m)
11. Lubricate O-ring (4) and install on to seat (5), thread seat in valve block. (Be careful not to damage bore in the seat.) Torque to 15 lb-ft (20.34 N•m).

12. Apply vaseline to shank of cone (13) and install spring (12) on cone. Carefully insert cone and spring into valve block positioning point of cone into bore of seat.
13. Lubricate O-ring (11) install in groove of piston (10) and insert end of piston into spring (12).
14. Lubricate O-ring (9) and install on housing guide (8) and thread into valve block. Tighten in place.
15. Thread nut (7) on socket set screw (6) and thread screw into housing guide (8) until it starts to compress spring.
16. Using a small bladed screw driver, thread the pilot replenishing relief valve assembly (36) into valve block and lightly tighten in place. (Not used in "V" units). (Do not over tighten. Over tightening can cause sides of slot to break now or at next removal.)
17. Lubricate O-ring (4) and install on plug (25) and tighten plug in place.
18. Thread check valve (2) into valve block and lightly tighten in place. (Do not over tighten.) Lubricate O-ring (22) and install on plug (23) and tighten in place.
19. Repeat step 19., on other end of valve block.
20. Lubricate O-ring (19) and install on plug (20) and tighten plug in place.
21. Lubricate O-rings (22) and install over plugs (23) and tighten plugs in place.
22. Lubricate O-rings (4) and install on plugs (25) and tighten in place.
23. Lubricate O-ring (19) and install over plug (20) and tighten in place.
24. Lubricate O-rings (47) and install in underside of manifold block (15). Carefully, place manifold block (15) on top of the valve cover (1) making sure the O-rings are correctly seated. Secure with four (4) soc. hd. cap screws (41) by threading into valve block (25).
25. Insert spring (16) and spool (38) into manifold (15) with the spring guide and spring towards the left side of the manifold (15) when viewing from the top rear. Install orifice plug (61) in manifold (15).
26. Install temporary plug (50) in 1/4" tube port. Insert O-ring (19) and plug (20) in alternate drain port.
27. Using a small hammer carefully tap roll pins (46) into and thru the retainer plate (42), the pins should bottom out in hole leaving enough length sticking out for piloting into the port block.
28. Lubricate O-ring (47), (48) and (37) and install in the bottom of retainer plate (42).

Valve is ready to install on pump.



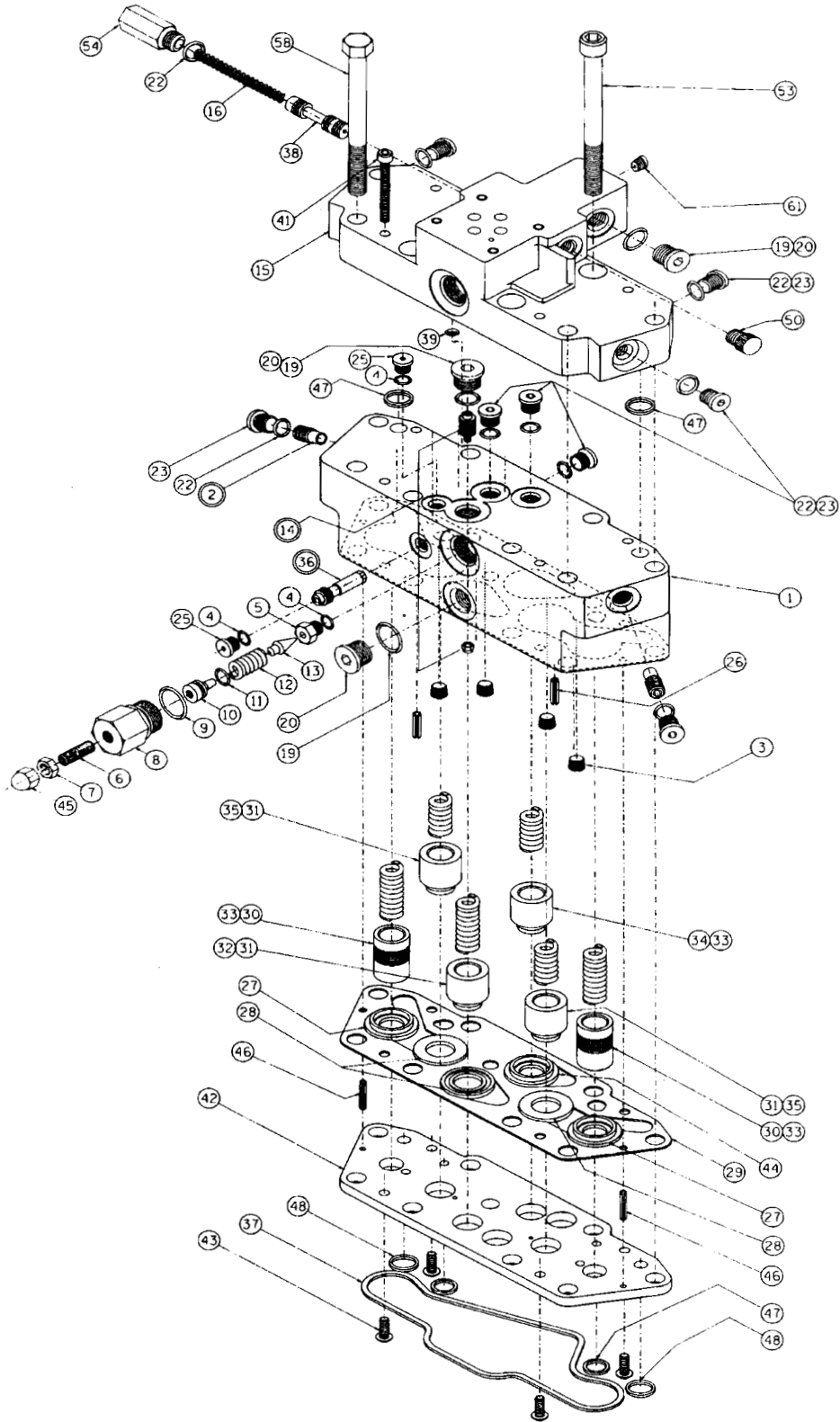

Assembly No.  
S23-12776

**FIGURE 13**  
**VALVE ASSEMBLY FOR SERVO VALVE MOUNTING**  
**(AFTER 7-93)**

**PARTS LIST FOR FIGURE 13**

ITEM	DESCRIPTION	PART NO.	QTY.
1	Valve block	033-91335	1
2	Valve check	S13-40266	2
3	Orifice #56 (.0465)	033-91249	4
4	O-ring, 90 S-1 ARP 903	691-00903	3
5	Seat	033-70508	1
6	Set Screw, 5/16-24 x 1 cup pt	312-13160	1
7	Hex jam nut	335-13100	1
8	Guide-housing	033-70545	1
9	O-ring, 90 S-1 ARP 910	691-00910	1
10	Piston	033-21767	1
11	O-ring, 70 S-1 ARP 012	671-00012	1
12	Spring	036-12289	1
13	Cone	036-12288	1
14	Servo strainer	S13-43240	1
15	Manifold	033-54389	1
16	Spring (Lee #LC-038C-19)	225-92083	1
19	O-ring, 90 S-1 ARP 906	691-00906	3
20	Plug 6HP5N- PL	488-35041	3
22	O-ring, 90 S-1 ARP 904	691-00904	10
23	Plug, 4HP5N-S w/o PL	488-35001	9
25	Plug (3 HPSN-S)	488-35049	2
26	Roll pin 3/16 x 3/4	325-12120	2
27	Seat Sys Relief	033-70507	2
28	Servo Seat	033-70500	3
29	Gasket	033-91193	1
30	Poppet	033-72378	2
31	Poppet	033-72379	3
32	Spring (light weight)	033-22141	1
33	Spring (1.437 (36.5 mm) O.A.L.)	033-70512	3
34	Poppet, Servo relief	033-54398	1
35	Spring (1"(25.4 mm) O.A.L.)	033-71086	2
36	Valve, Repl	S23-12699	1
37	O-ring, 70 S-1 ARP 050	671-00050	1
38	Spool	033-54392	1
39	O-ring, 90 S-1 ARP 008	691-00008	1
41	Screw, Soc Hd 10-24 x 1-1/4	358-10180	4
42	Retainer plate	033-91422	1
43	Screw	353-25078	4
44	Seat, Servo relief	033-54399	1
45	Acorn nut	327-25006	1
46	Rollpin 1/8 x 3/4	325-08120	2
47	O-ring, 70 S-1 ARP 013	671-00013	6
48	O-ring, 70 S-1 ARP 014	671-00014	2
50	Plug 7/16-20	449-00013	1
53	Screw, Soc Hd 3/8-16 x 4	358-16360	4
54	Plug	035-54400	1
58	Screw, Hex Hd	306-40132	4
61	Orifice #56 (.0465)	033-25528	1

**Shaft assembly Installation See Figure 14**

1. Position pump so that it rests on port block face.
2. Install the shaft and bearing assembly (1) in the mounting flange and cradle. Be certain that there are no burrs or sharp edges on shaft seal area of the shaft.
3. For a rigid shaft application use the shim (2) that results in least clearance around the shaft bearing. Do not use a shim with a floating shaft. Remove the two screws that were temporarily used to hold the cradle in the mounting flange.
4. Install the retaining ring (3) in the mounting flange.

**Seal Assembly See Figure 14**

**NOTE:** See Warning Information Below.

1. The shaft seal is available only as a complete assembly. Prior to installation examine all the seal parts. Handle the lapped seal seat and the carbon ring with extreme care. Both parts must be free of scratches, cracks or other damage.

**Removing Old Shaft Seal Parts (Field Service Kit S23-12113)**

1. Remove four (4) 3/8-16 UNC x 2-1/4 hex head cap screws which hold the seal retainer (033-71574) to the mounting flange (033-71546).
2. Remove and discard old "Nyltite" gaskets (1) from bolts.
3. Remove seal retainer (033-71574) from mounting flange.
4. Remove seal retainer gasket (033-71567) and excess material from mounting flange counter-bore.
5. Remove rotating part of shaft seal (623-00008) and excess material from shaft.
6. Remove bearing retaining ring (356-65013).

**Installing Replacement Parts as Shown On S23-12113**

1. Install special bearing retaining ring (3).

2. Use the operating oil to lubricate the shaft, shaft seal boot, carbon seat, ceramic face, square seal and seal retainer O-ring.
3. After lubricating shaft and seal boot, slip seal boot onto shaft until spring retainer bottoms on bearing, being very careful not to damage the carbon seat.
4. Lubricate and install the O-ring (2) and stationary parts of the shaft seal (5) into the seal retainer (4). Install new "Nyltite" gaskets (1) on the four bolts.
5. Align the seal retainer and mounting flange bolt holes, then slide against the mounting flange counter-bore. It may be necessary to alternately tighten the bolts to overcome the shaft seal spring force. Torque the bolts to 30 ft./lbs. (40.8N•m).
6. Using a strap wrench, check to see that the shaft rotates smoothly and take corrective action as necessary.
7. Depress the seal retainer only far enough to start the screws and tighten evenly in a criss-cross pattern. Torque to 30 ft./lbs. (40.8 N•m).

**Counter-Balance Servo Stem Assembly See Figure 14**

1. Install balance stem (9) on rocker cam using two #10-32 screws (10). Torque to 70 in./lbs.(7.91 N•m).
2. Place the two spacers (12) on the screws (13) and install through the balance plate (11).
3. Align screws with threaded holes in balance stem and tighten. Torque to 70 in./lbs.(7.91 N•m).

**Control Cover Assemblies**

1. Lubricate O-ring (19 & 20) and install in counterbore and groove in covers. (Some covers use gasket 033-91058)
2. Install the cover assemblies (16 & 17) over the dowel pins on the housing pads and secure with seals (14) and screws (15). Torque to 30 ft. lbs.(40.8 N•m).

**Note:** The input cover assembly must be installed on the right hand side of the housing on pumps with "B" suffix. Install the output cover assembly on the right hand side on models with "A" suffix.

**Mechanical shaft seal assembly procedure**

Warning: When installing a new mechanical shaft seal, exercise care to insure that all of the parts fit together properly. This is particularly important if the seal was once assembled and disassembled for some reason. If the rubber boot, item 4, grips the shaft and doesn't slide on the shaft, as it is disassembled, then the spring, item 7, can disengage the shell, item 5, from the band, item 6, so that they do not re-engage properly when reassembled. Be sure the shell and the band are properly engaged before reassembling the seal, and stays engaged during assembly.

Note:  
Lubricate seal and shaft with clean hydraulic fluid of the same type that will be used in the system.

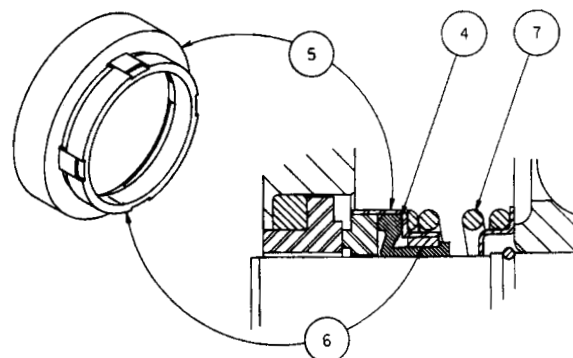

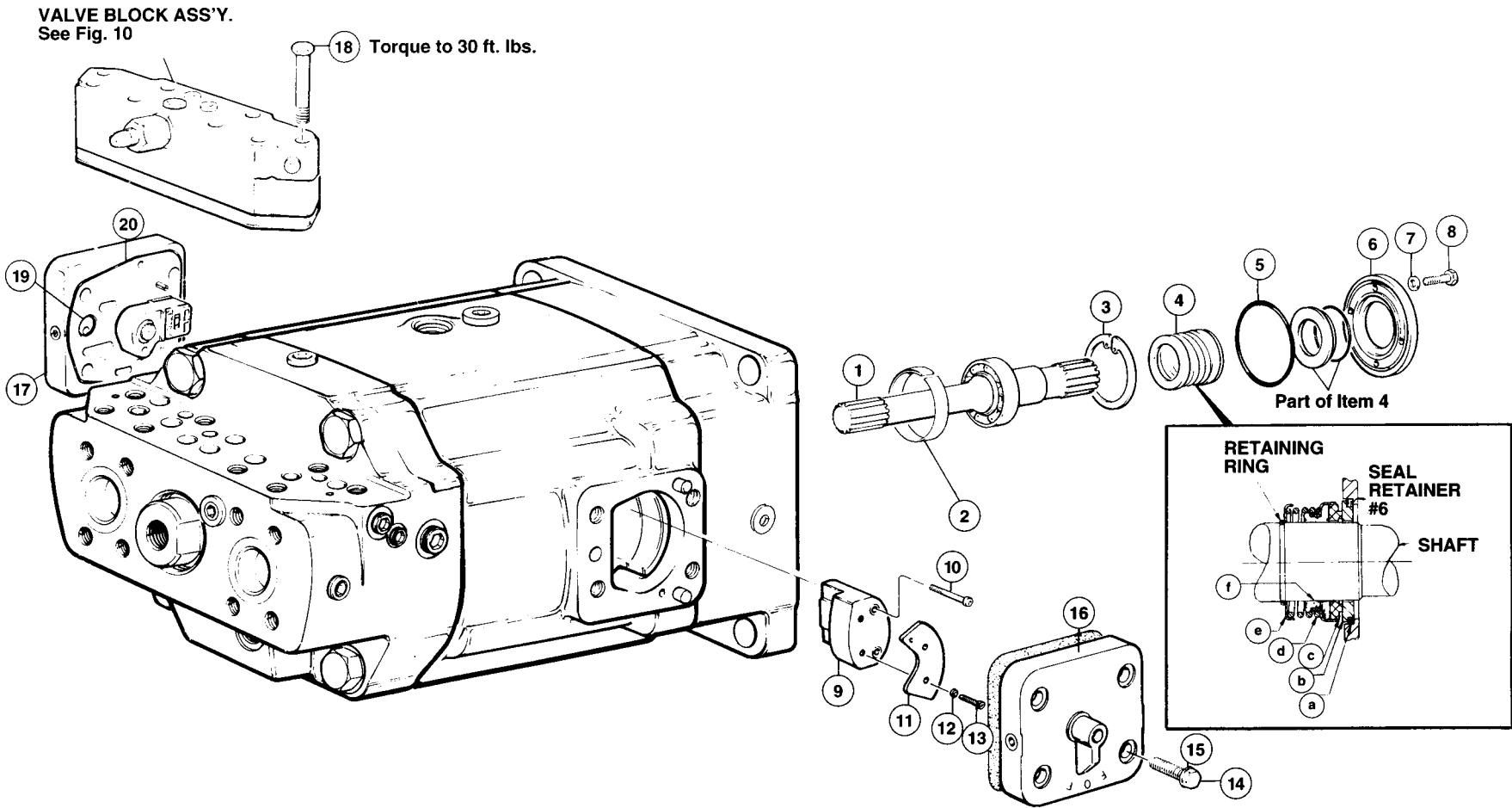

FIGURE 14

**PARTS LIST FOR FIGURE 14**

ITEM	DESCRIPTION	PART NO.	QTY.
1	No. 3 Splined Shaft Assy. (See fig. 1)	S13-43968	1
	No. 2 Keyed Shaft Assy. (See fig. 1)	S15-43969	
2**	Shim .008 (.203 mm) (use only 1)	033-53983	1
	Shim .007 (.178 mm)	033-53984	
3	Retaining ring (after April '90)	356-65013	1
4	Shaft seal (after April '90)	623-00016	1
5	Seal retainer O-ring	671-00249	1
6	Seal retainer	033-57872	1
7	Nyltite gasket	631-45007	4
8	Hex. Head Screw	306-40021	4
9	Balance stem	033-71616	1
10	Soc. hd. cap screw	359-09240	2
11	Balance plate	033-70546	2
12	Spacer	033-71247	2
13	Soc. hd. cap screw	359-09180	2
14	Nyltite washer	631-45007	8
15	Hex. hd. washer screw	353-25018	8
16	Control assy. (Output)	See below	1
17	Control assy. (Input)	See below	1
18	Hex. hd. cap screw 3/8-16 x 3-1/4	306-40169	8
19*	O-ring	671-00017	1
20*	O-ring	671-00048	1

\*Some controls use gasket 033-91058 in lieu of O-Rings (cast iron covers).  
 Powder metal covers have groove for O-Ring 671-00048, 671-00017.

\*\*For rigid shafts.

Output Control		Part No.
Standard, with volume indicator		S13-42064
Torque limiter		S23-12299 A/B
		S23-12298 [ *B* MTG CW *A* MTG CCW
		S23-12300 [ *A* MTG CW *B* MTG CCW
Input Control		
10*	S23-12327	[ *B* MTG. CW *A* MTG. CCW
10*	S23-12328	[ *B* MTG. CCW *A* MTG. CW
2H*	S23-12358	
40*	S23-12344	
4A*	S23-12325	
4B*	S23-12343	
4C*	S23-12324	
5A*	S23-12413	—'0' deadband
5C*	S23-12414	
60*	S13-48944	
6B*	S23-12424	
8A*	S23-12268	
8C*	S23-12820	
9A*	S23-12667	
9C*	S23-12925	



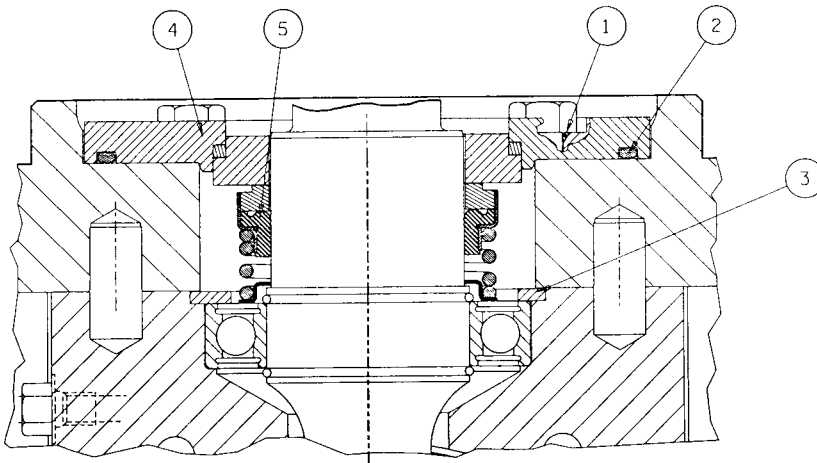

### "Field Kit"

S23-12113 — For repair of units shipped prior to April, 1990

ITEM	DESCRIPTION	PART NO.	QTY.
1	Gasket Nylite	631-45007	4
2	O-Ring	671-00249	1
3	Retaining Ring-Special	033-57875	1
4	Seal Retainer	033-57872	1
5	Shaft Seal	623-00016	1

**Note:** Shaft Seal Field Repair Kit S23-12113 to be used for all Shaft Seal Replacements prior to April 1990

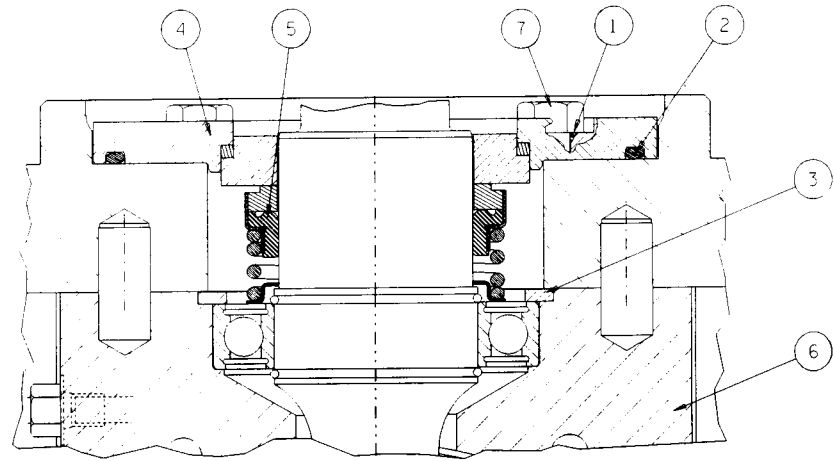

### "Production Kit"

S23-05992 — For repair of units shipped after April 1990

ITEM	DESCRIPTION	OLD PART NO.	NEW PART NO.
1	Gasket Nylite	631-45007	671-45007 *
2	Gasket O-Ring	033-71567	671-00249 674-00249 * 675-00249
3	Retaining Ring	033-57875	356-65013
4	Seal Retainer	033-71574	033-57872
5	Shaft Seal	623-00008	623-00016-0 623-00016-4 * 623-00016-5
6	Fixed Cam	033-53989	033-57880
	Rocker Cradle	033-53988	033-57879
7	Screw (4)	353-25021	306-40021

\*Shaft Seal Kit



**Replenishing Circuit Isolation Plug  
(P Units Only)**

**CAUTION:** The isolation plug enclosed is to be used **ONLY** if an external filter circuit is provided. **DO NOT** operate this unit with the isolation plug installed unless an external line has been provided.

When the external filter circuit **IS NOT** used discard the isolation plug.

When the external filter circuit **IS** used, install the isolation

plug under the plug in the face of the port block. Use a 3/16" (4.76 mm) Hex. wrench, 4" minimum in length. Insert the isolation plug and tighten to 80 - 120 in.-lb. torque. (9.04-13.56 N•m)

**CAUTION:** The filter must have bypass and bypass indicator. Denison Hydraulics recommends it be sized to four times the expected flow.

Isolation plug kit: Part No. S13-44178  
(Plug Part No. 431-90200)

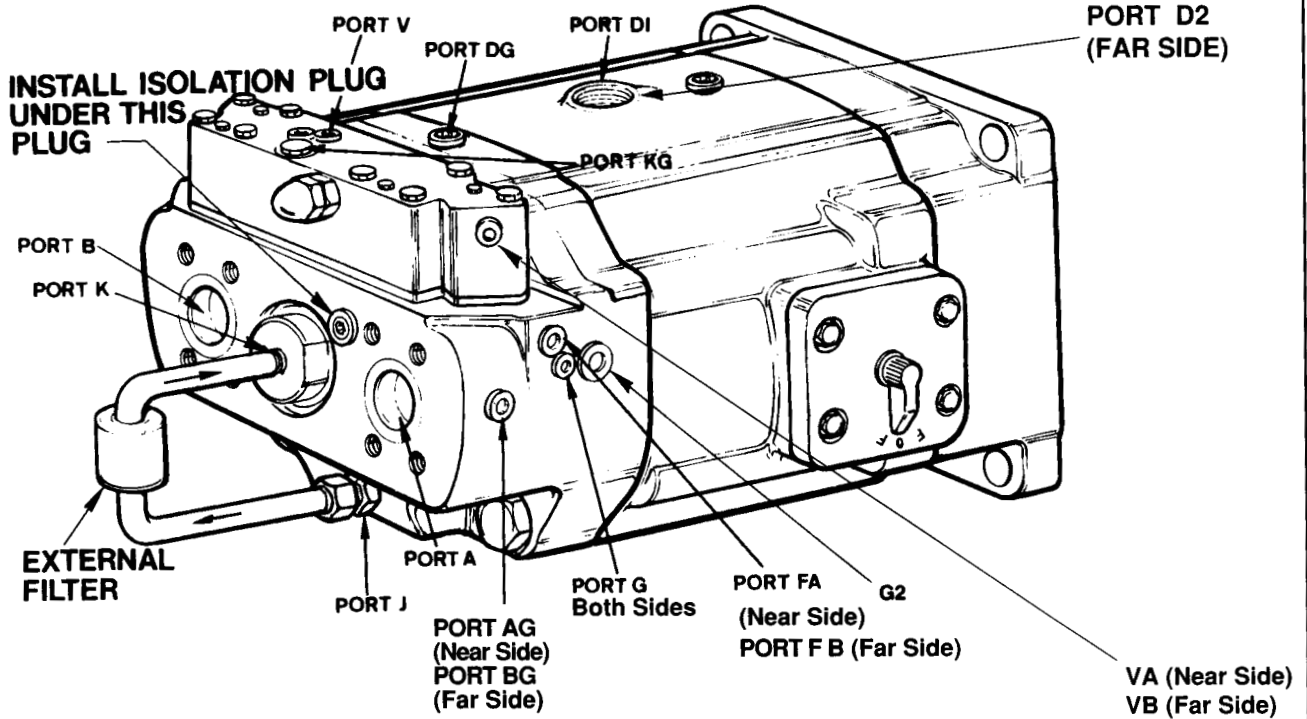

**Port Location**

Port	Size	Function
A	4 Bolt SAE 6000 psi	Inlet / Outlet
AG	SAE - 6 Straight Thread	System Pressure Gage, near side
BG	SAE - 6 Straight Thread	System Pressure Gage, far side
B	4 Bolt SAE 6000 psi	Outlet / Inlet
D1	SAE - 16 Straight Thread	Case Drain
D2	SAE - 16 Straight Thread	Case Drain
DG	SAE - 6 Straight Thread	Case Pressure Gage
FA	SAE - 6 Straight Thread	Control Pressure Gage, near side
FB	SAE - 6 Straight Thread	Control Pressure Gage, far side
G	SAE - 4 Straight Thread	Servo Pressure to Control
G2	SAE - 8 Straight Thread	Servo Pressure (A side only)
J	SAE - 10 Straight Thread	Auxiliary Pump Outlet
K	SAE - 16 Straight Thread	Replenishing Pressure
KG	SAE - 6 Straight Thread	Replenishing Pressure Gage
V	SAE - 4 Straight Thread	Remote Compensator Control
VA / VB	SAE - 4 Straight Thread	Individual Vent Compensator Control

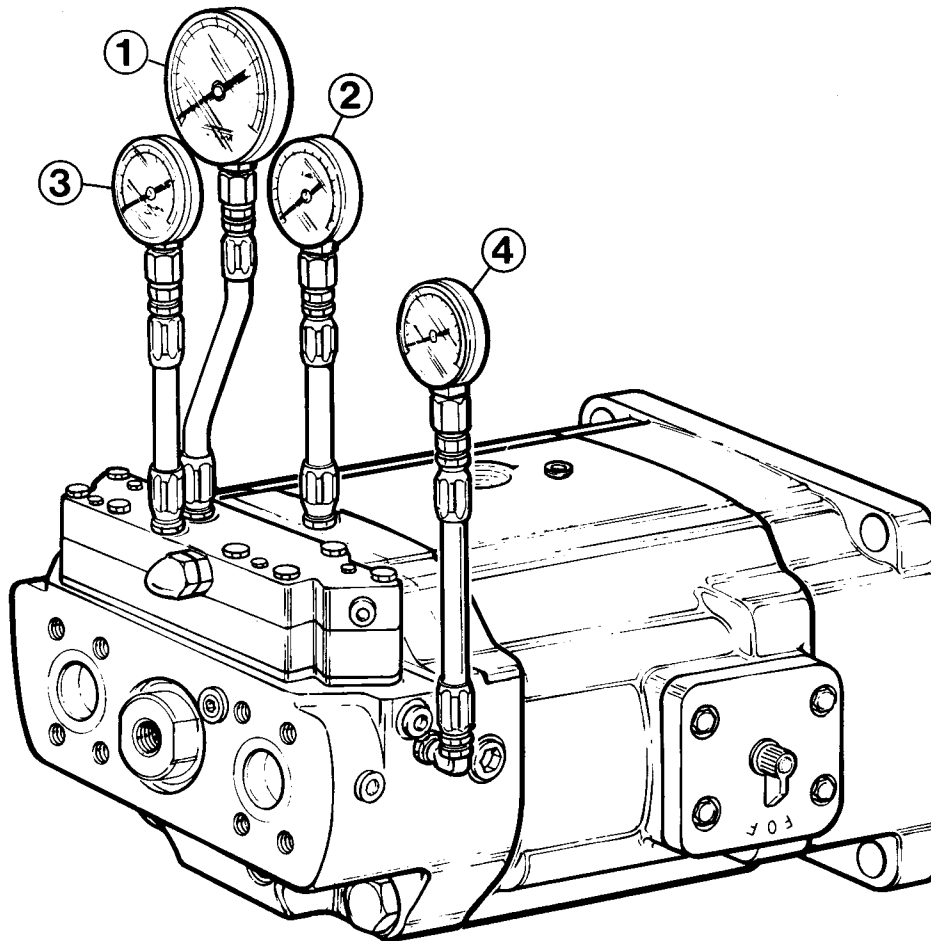

**Caution:** When installing system Pressure Gage (#1), "V" port. Make certain loose modulating pin (Item 40, Fig. 10) is retained in the port.

**Note:** Do not install Gage in Replenish filter line when isolation plug is installed without "T" fitting. **FAILURE TO DO SO WILL RESULT IN AUXILIARY SHAFT FAILURE.**

- 1. Pressure Gage: System A or B  
10,000 psi ( 690 bar )
- 2. Case Pressure Gage: 150 psi (10.3 bar)
- 3. Replenishment Gage: 300 psi (20 bar)
- 4. Servo Pressure Gage: 600 psi (42 bar)

### Typical Pressures

Closed Loop	Open Loop
<b>Replenishment:</b> 180-220 PSI (12.4-15.2 bar) + Case Pressure	<b>Replenishment:</b> None
<b>Servo:</b> 150 PSI (10.3 bar) + Case PSI + 40 PSI (2.75 bar) per 1000 PSI (68.9 bar) system pressure.	<b>Servo:</b> 160 PSI (11 bar) + Case PSI + 62.5 PSI (4 bar) per 1000 PSI (68.9 bar) system pressure.
<b>Case:</b> 75 PSI (5.2 bar) continuous 125 PSI (8.62 bar) intermittent	<b>Case:</b> 25 PSI (1.7 bar) maximum above Inlet

**General Requirements:**

1. Maximum runout between pump shaft and electric motor shaft .003 T.I.R. A floating shaft must have a support in mounting bracket. A fixed shaft should not have a support bearing in mounting bracket.
2. Electric motor speed—1800 RPM.
3. Inlet temperature—130° ± 10°F. (54°C ± 4°C)
4. Inlet condition—Main Pump—100 to 150 PSI.  
Gerotor —10" HG to 5 PSI.
5. Case pressure 65 PSI ± 10 PSI. (4.5 ± .69 bar).
6. Fluid—200SSU @ 100°F. (37.8°C)

**Basic Pump Test**

1. Mount pump on test stand. Connect system lines and gerotor inlet line to pump. Fill pump case with clean oil. Dry all oil from pump to permit checking for external leaks.
2. Start electric motor. Jog several times before continuous running.
3. Rotate pump input control shaft. The servo control should control pump displacement through its full range. Set pump displacement for full volume, and adjust system pressure for 1000 PSI (69 bar). Check and record system flow and case drain flow with cam above and below center. Monitor loop temperature.

	11.0 IN <sup>3</sup>	14.0 IN <sup>3</sup>
<b>Maximum System Flow</b>	86 GPM (325.5 l/m)	110 GPM (416.3 l/m)
<b>Maximum Case Drain Flow</b>	2.5 GPM (9.5 l/m)	2.5 GPM (9.5 l/m)

4. Back out compensator adjusting screw until unit is fully compensated (count number of turns). Observe volume indicator and stroke rotary servo input shaft from full to full position on each side of center. Indicator should remain on or very near zero position ("O"). If compensator functions normally, return compensator adjusting screw to its original position and proceed with Step 5.

**Caution:** Do not over-tighten cap screw.

5. Cycle pump at 10 sec. intervals-full volume above center to full volume below center\*—as follows:

- 8 minutes at 1000 PSI (69 bar)
- 5 minutes at 2500 PSI (172 bar)
- 3 minutes at 5000 PSI (345 bar)

6. Adjust system pressure to 5000 PSI (345 bar) and set pump displacement for full volume. Check and record system flow and case drain flow above and below center.

\*Pumps with screw adjustment controls do not need to be cycled.

	11.0 IN <sup>3</sup>	14.0 IN <sup>3</sup>
<b>Minimum System Flow</b>	72 GPM (272.5 l/m)	96.0 GPM (363.3 l/m)
<b>Maximum Case Drain Flow</b>	4.5 GPM (17 l/m)	5.5 GPM (20.8 l/m)

7. Set pump to compensate at 5000 PSI (345 bar). (Servo pressure should be at least 500 PSI (34.5 bar). Check and record gerotor flow.)

**Minimum Flow** 13.5 GPM (51.1 l/m),  
(13.0 GPM (49 L/m) for pumps with brake and by-pass valve)

8. Set pump to compensate at minimum PSI. Check and record replenishing and servo pressure.

**Servo Pressure-Minus Case Pressure**-308 to 420 PSI  
(21.2 to 29 bar).

**Repl. Pressure-Minus Case Pressure**-200 PSI ± 20 PSI  
(13.8 ± 1.4 bar).

If pressures are incorrect, remove replenishing relief valve pilot and increase or decrease pressure as required. (One full turn on adj. screw will cause pressure to change approximately 25 PSI) (1.7 bar). Re-torque locknut to 20-25 in/lbs. (2.3-2.8 N•m).

**Note:** There is no servo relief valve adjustment. Increasing or decreasing repl. pressure will cause both servo and repl. pressure to change by the same amount.

9. Set pump to compensate at 5000 PSI (345 bar). Record repl. and servo pressure.

**Servo Pressure-Minus Case Pressure**-508 to 620 PSI  
(35 to 42.8 bar).

**Repl. Pressure-Minus Case Pressure**-200 ± 20 PSI  
(13.8 ± 1.4 bar).

10. Set pump to compensate at minimum PSI. Servo pressure should return to 308 to 420 PSI (21.2 to 29 bar).

**Note:** After completing step 10, proceed with pump control test and adjustment on pages 33 and 34. Continue with step 11 after testing controls.

11. Adjust pump displacement for full volume and adjust system pressure to 6000 PSI (413.8 bar).\*\*Adjust compensator from 6000 PSI to minimum pressure in 1000 PSI (69 bar) intervals. At each pressure, stroke rotary servo input shaft to the full position on each side of center. Cam indicator should remain on or very near the zero position with no oscillation. System pressure should not vary from Port "A" to Port "B" more than 150 PSI (10.3 bar) and not oscillate.

**Minimum compensator pressure should be under 500 PSI (34.5 bar)**

**\*\*Caution:** DO NOT hold pump at 6000 PSI (413.8 bar) for longer than one minute at any time. This is only an intermittent pressure rating.

12. Increase compensator adjustment to 1000 PSI(70 bar) and increase and decrease system pressure above and below compensator setting. When system pressure is above compensator setting, the pump should de-stroke and not oscillate. When the system pressure is below the compensator setting, the pump should stroke to full volume. Repeat at 5000 PSI.(345 bar)

13. Check pump for external leaks. No external leaks permitted.

14. After all tests are complete re-torque main housing bolts to 350 ft.-lbs.(476 Nm)

**MANUAL PUMP CONTROLS—  
TEST AND ADJUSTMENT**

**Type 1 Control— (SCREW ADJUSTMENT)**

1. Turn control knob in and out. The pump rocker cam should follow the control over the full range, from full to 0. Set minimum volume stop at 0 volume & screw adjustment control at maximum volume, UNLESS OTHERWISE SPECIFIED.

PUMP ROTATION	INPUT ROTATION A MOUNTING	INPUT ROTATION B MOUNTING
CW	CW	CCW
CCW	CCW	CW

**Type 3 Control— (Rotary Servo)**

1. Rotate pump servo input control shaft. The servo control should control pump displacement through its full range. There should be no oscillation, sluggishness, or erratic movement of pump rocker cam as the input control is rotated. Check at several pressures between 200 and 5000 PSI (13.8 and 345 bar).

**Type 4 and 4A Control— (Rotary Servo with Spring and Pressure Centering)**

- Adjust system relief valve for 2000 PSI (137.9 bar).
- Remove acorn nut on control and center pump by rotating adjusting screw. Pump is on center when both system ports are at minimum pressure. Tightly lock adjusting screw at center position.
- Rotate pump servo input control shaft. The servo control should control pump displacement through its full range. There should be no oscillation, sluggishness, or erratic movement of pump control as the input control is rotated. Stroke pump to maximum volume above and below center. Release input shaft. Pump should return to 0 displacement each time. Check at several pressures between 200 and 5000 PSI (13.8 and 345 bar).

4. If control has adjustable volume stops, "Type 4A", set stops at maximum volume, UNLESS OTHERWISE SPECIFIED.

**Type 4B and 4C Control— (Rotary Servo with Brake and Neutral By-pass and Pressure Centering.**

- Connect neutral by-pass exhaust port, through a needle valve, to tank.
- Install a 1000 PSI (70 bar) gage in the brake actuator port.
- Adjust system relief valve for 5000 PSI (345 bar).
- Remove acorn nut on control and center pump by rotating adjusting screw. (Close needle valve on neutral by-pass port during this operation.) Pump is on center when both system ports are at minimum pressure. Tightly lock adjusting screw at center position.
- Rotate servo input shaft CW. The gage on the brake port should start to indicate servo pressure when the system pressure is between 2000 and 4500 PSI (137.9 and 310.3 bar), with an increasing signal, and must return to case pressure before system pressure drops to 2000 PSI (137.9 bar), on decreasing signal. Repeat by rotating input shaft CCW. Record both pressures for each rotation of the servo input shaft.
- Increase system pressure to 5000 PSI (345 bar). Open the needle valve on the neutral by-pass port. Rotate the rotary servo shaft, and measure and record leakage from the needle valve.

**Maximum Leakage with control on center:**  
2.0 GPM (7.6 l/m)

**Minimum Leakage with control on center:**  
1.0 GPM (3.8 l/m)

**Maximum Leakage with control off center:**  
35 cu. in./min. or .15 GPM (574 cm3/min. or .57 l/m)

7. Stroke pump above and below center. Control should operate smoothly. Brake pressure should drop to case pressure each time control is on center, and it should indicate servo pressure as soon as input shaft is rotated CW or CCW from center, per instructions in Step 5, above.

Release control when pump is off center. Pump should return to center. Repeat several times in each direction and at different pressures from 200 to 5000 PSI (13.8 to 345 bar).

8. If control has maximum volume stops, "Type 4C", set at full volume UNLESS OTHERWISE SPECIFIED.

**Type 5A and 5C-01 Control W/O Center Dead Band**

Connect the servo pressure thru a needle valve into the fitting on the side of the controller body.

- For Type 5C controller, connect neutral by-pass exhaust port through a needle valve to tank. Install a 1000 PSI (70 bar) gage to the brake port.
- Install a six inch lever on the input shaft.



3. Connect the electrical connector. The power supply must have  $\pm 400\text{MA}$  capability with a switch in series with the connector.

**Operational Test**

1. Plug the servo feed line.
2. Open the switch to the controller (0 current).
3. With the pump running, stroke the pump manually 1/2 to 3/4 volume each side of center to confirm pump operation.
4. Set test stand relief valve(s) to 2000 PSI (137.9 bar).
5. Adjust the unit to center with the mechanical adjustment on the control cover plate. Pressure on each system port must be within 100 PSI (6.9 bar) of the other. Manually stroke the pump each side of center and release. The pump must return to center from each side.
6. Reconnect the servo supply . Adjust the null screw at the top of the force motor (near connector) until the pump is at center. Slowly adjust the screw CW until the pump starts to build pressure. Note the position of the slot on the screw at this time. Slowly adjust the screw CCW until pressure builds the opposite side of center. Note the position of the screw. Turn the screw back CW to the position directly between the two positions at which pressure starts to build and lock in place.
7. Slowly apply + current to the valve. Note the value of current at which pressure starts to build (e.g. +40MA). Back off current and slowly apply - current to the valve. Note the value of current at which pressure builds the opposite side of center (e.g. -50MA) the sum of the current magnitudes must be to 50 to 100 MA (e.g. 40+50=90MA) and each reading must be within 20MA of the other (e.g. 40&50 are within 10MA and therefore acceptable). If the sum of current magnitudes are not within specification, the control must be rejected. If the value on each side of center is not within spec., readjust the control until this specification is met.
8. Apply +400MA to the control. The pump must go to full displacement (flow per para. 3). Apply -400MA and the unit must go to full displacement the opposite direction. The max stops on the control may have to be adjusted. If the control does not stroke the pump to full, plug the servo to the stroker & stroke the unit to full manually. If the pump goes to full, reject the control. If the pump does not go to full, the problem is in the pump.
9. Upon completion of the test, the stops may be set as req'd if other than full displacement.
10. Close the switch & stroke the unit to full displacement. Open the switch and observe the unit return to center. A & B pressures must remain within 300 PSI (20.7 bar) at center. Repeat this stroking the opposite side of center.
11. Apply 400MA to get full displacement then plug the servo. The control should spring center in three seconds. Repeat the test for -400MA.

12. Reconnect servo. Apply +50MA, then open the switch.Repeat with -50MA. Observe that the pump nulls in each case. If it does not, recheck the null per Test 8.

13. The mechanical stops are preset to  $\pm 19^\circ$ . If something other than this is requested, the two adjusting screws on either end of the control cylinder can be turned to the desired flow or displacement.

**Type 60 & 6B Hydraulic Stroker Control**

1. Connect external 400 PSI (27.6 bar) servo source to control ports on hydraulic stroker through a 4-way valve. Center position must dump both ports to tank at min. pressure.
2. Null the pump with the mechanical adjustments on the end covers of the 60 control. See centering procedure, page 40.
3. Apply servo pressure to one port of stroker. Adjust pressure from minimum. Note the control pressure at which pump just starts to stroke, and the control pressure at which pump reaches full volume. These pressures must be within the following values:

CONTROL	CONTROL PRESSURE (PSI)	
	START	FULL
60/6B—00	75 $\pm$ 15 (5.7 $\pm$ 1.03 bar)	335 $\pm$ 25 (23.1 $\pm$ 1.7 bar)
60/6B—01	75 $\pm$ 15 (5.7 $\pm$ 1.03 bar)	435 $\pm$ 25 (30 $\pm$ 1.7 bar)
60/6B—02	110 $\pm$ 10 (7.6 $\pm$ 0.7 bar)	375 $\pm$ 25 (25.9 $\pm$ 1.7 bar)

**Note:** If incorrect, add or delete shim washer to spring box assy. One washer 033-53452 will alter control pressure by 20 PSI. (1.4 bar). Readjust null per centering procedure on page 40.

4. Observe stroke versus control pressure. Stroke shall change gradually with no jumps, from zero to full.
5. With min. signal, pump shall return to min. press. within 200 PSI (13.79 bar) max.
6. Repeat test on opposite side of center.

**6B Hydraulic Stroker W/Brake & By-Pass**

1. Connect neutral bypass exhaust port, through a needle valve into the drip pan.
2. Install a 1000 PSI (70 bar) gage in the brake actuator port.
3. Center the pump per centering procedure beginning on page 40.
4. Connect an external servo source (400 PSI max.) (27.6 bar) to ports on the hydraulic stroker through a 4-way valve to direct flow to one port at a time.
5. Start pump.
6. Perform basic pump test.
7. After completing and accepting basic pump test, perform the following tests to the control.

8. Be certain that the pump returns to center from both above and below center after releasing stroking handle. Adjust spool (26) on S15-48572-C in or out as required until pressure at the brake port drops to case pressure. After pressure drops to case pressure, continue turning in the same direction until servo pressure returns. Reverse adjustment until pressure drops again to case pressure. Count the number of turns between these points. Try to locate the center position (with the brake port at case pressure) between the two points where the pressure at the brake port increases to servo pressure (adjust 1/2 the turns from above). Tighten lock nut at this point.

9. Rotate servo input shaft C.W. The gage in the brake port should start to indicate servo pressure when the system pressure is between 2000 and 4500 PSI (137.9 and 310.3 bar), with an increasing signal, and must return to case pressure before system pressure drops below 2000 PSI (137.9 bar), on decreasing signal. Repeat by rotating input shaft C.C.W. Record both pressures for each rotation of the servo input shaft. If the brake pressure does not fall within these limits, spool (26) can be adjusted to bring it within the limits.

10. Increase the system pressure to 5000 PSI (345 bar). Open the needle valve on the neutral by-pass port. Rotate the servo input shaft and measure and record leakage from the needle valve. Max. leakage with control on center: 2.0 GPM. (7.6 l/m). Min. leakage with control on center: 1.0 GPM. (3.8 l/m). Max. leakage with control off center: 35 cu. in./min. or .15 GPM. (574 cm<sup>3</sup>/min. or .57 l/m.).

**Centering procedure for 60, 6B & 6B2 controls**

1. Install a stroking handle on the input shaft.
2. Remove the end plugs from the spring boxes.
3. Loosen the adjusting screw lock nuts and back the screws out until the input moves freely thru at least ±3°, indicating that there is free play between the control piston and the stops.
4. Start the pump. Offset the control to one side so that one side pressure is high, the other low (Do not force handle past the 1st stop). Determine which adjustment screw upon which the input is resting, then slowly adjust that screw inward until center is reached (equal pressure, both ports).
5. Adjust the opposite adjusting screw inward until all free-play of the handle is gone. This may be checked by moving the input as the screw is adjusted, and observing the decreasing amount of motion which can be made until no motion exists.
6. Carefully tighten the lock nuts without changing the adjusting screw position (a special tool is helpful in doing this).
7. Attach the pilot lines to the control and cycle the control pressure several times in each direction. When control pressures are returned to zero, the system pressure gauges must be equal (unit centered). Repeat the above procedure as required until proper centering is attained.

**Type 8A Hydraulic Strocker Control**

1. Connect external 400 psi. (27.6 bar) servo source to control ports on hydraulic stroker through a 4-way valve. Central position must dump both ports to tank at min. pressure.

2. Center the pump as follows:

- a. Back out max. volume stops so that servo shaft link touches stop pins at full stroke.
- b. Loosen trimmer locknut.
- c. Install stroking handle on the shaft. Rotate handle slightly. There will be some backlash between end of spring and spring stop. Thread spring stop in or out until there is no free play when the handle is stroked. Lock spring stop with lock nut.
- d. Adjust trimmer so that when handle is released, either side, spool returns to 0° degrees. Lock trimmer with locknut.
- e. Adjust and lock max. volume stops at 19° or as required.

3. Apply servo pressure to one port of stroker. Adjust pressure from minimum. Note the control pressure at which pump just starts to stroke, and the control pressure at which pump reaches full volume. These pressures must be within the following values:

CONTROL	CONTROL PRESSURE (psi.)	
	START	FULL
8A-00	75 ± 15 (5.7 ± 1.03 bar)	335 ± 25 (23.1 ± 1.7 bar)
8A-01	75 ± 15 (5.7 ± 1.03 bar)	435 ± 25 (30 ± 1.7 bar)
8A-02	100 ± 15 (7 ± 1.03 bar)	380 ± 25 (26.2 ± 1.7 bar)
8A-03	150 ± 15 (10 ± 1.03 bar)	400 ± 25 (27.6 ± 1.7 bar)
8A-04	75 ± 15 (5 ± 1.03 bar)	250 ± 25 (17.2 ± 1.7 bar)

4. Observe stroke versus control pressure. Stroke shall change gradually with no jumps, from zero to full.
5. With min. signal, pump shall return to min. press. within 200 psi. (13.79 bar) max.
6. Repeat test on opposite side of center.



**Dampened Torque Limiters**

1. Prior to start up, remove the high pressure tube line from torque limiter and cap or plug all open ports.
2. Test basic pump. After compensator has been set per customer's requirement reconnect tube lines removed in Step 1.
3. Start pump and stroke rotary servo to full stroke. Note system flow.
4. Slowly increase the system pressure until the flow value noted in Step 3 starts to drop. Observe the system pressure at this time, and compare to the pressure drop off value, (Point where limiter start to control) obtained on the preliminary test. It should be within  $\pm 200$  PSI (13.8 bar). If incorrect, adjust the torque limiter and trimmer screws accordingly. In addition, note the amp draw on the electric motor.
5. Slowly increase the system pressure to a value 500 PSI (345 bar) less than the compensator setting. Again, note the electric motor amp draw. It should be within  $\pm 10$  amps of that obtained in Step 3. If incorrect, adjust the torque limiter and trimmer screws accordingly, and secure all lock nuts.
6. Repeat Steps 4 & 5 (without disturbing adjusting screws) to insure repeatability.
7. Clean all fluid from the exterior of control and inspect for leaks. None permitted.

**Type 2A Pump Controls (Cylinder Control)**

1. Pump discharge will be "B" Port unless otherwise specified.
2. Move Rotary Servo. The input should move freely between the maximum and minimum stops and spring return to minimum. Set the minimum stop to zero disp. and the maximum stop to full disp. unless otherwise specified.
3. Connect X and Y to servo and tank as indicated in the chart below and observe that the indicated displacement is attained.

Pump Rotation	Control Pos.	Discharge Port (pres)	For Max. Disp. Pressure To
CW	A	B	Y
CW	B	B	X
CCW	A	B	X
CCW	B	B	Y
CW	A	A	X
CW	B	A	Y
CCW	A	A	Y
CCW	B	A	X

**Model Number** P 14 P 1 R 1 \* -4 C 2 -B -00 -0 -0 0 -M2-XXXXX

**Pump series**

**Displacement, Max.**  
 11 = 11.0 in<sup>3</sup>/rev., (180 cm<sup>3</sup>/rev.)  
 14 = 14.0 in<sup>3</sup>/rev., (229 cm<sup>3</sup>/rev.)

**Pump type**

P = closed loop  
 V = open loop

**Shaft**

2 = keyed  
 3 = spline  
 SAE-E = 11 & 14

**Rotation, shaft**

viewed from shaft end  
 R = clockwise  
 L = counter-clockwise

**Fluid class**

1 = compatible w/Buna N  
 4 = compatible w/EPR  
 5 = compatible w/Viton

**Design letter** - assigned by manufacturer

**Primary controls**

omit fixed displacement  
 1 = screw adjustment  
 2 = cylinder control  
 4 = rotary servo-spring centered w/trimmer  
 5 = electrohydraulic stroker  
 6 = hydraulic stroker  
 7 = servovalve & feedback device  
 8 = proportional hydraulic stroker  
 9 = electrohydraulic stroker

**Primary controls, options**

0 = none  
 A = adjustable maximum volume stops  
 B = automatic brake control  
 C = A & B combined  
 D = 10 gpm servovalve w/feedback potentiometer  
 E = 10 gpm servovalve w/feedback RVDT  
 F = 10 gpm servovalve w/pot. & man. override -w/4A2 control  
 G = 10 gpm servovalve w/2/RVDT & man.override -w/4A2 control  
 H = 3 position 2A control

**Secondary controls**

2 = auxiliary replenishment port on centerline  
 4 = torque limiter and auxiliary replenishing port

**Control location**

A = command on port A side, displ. ind. on opp. side  
 B = command on port B side, displ. ind. on opp. side

500 control	600 control	700 control	8A2 control	9A2 control
00 = w/deadband	00 = 75-350 psi, (5-24 bar)	00 = w/o man. override shut-off	00 = 75-350 psi, (5-24 bar)	w/o deadband
01 = w/o deadband	01 = 75-435 psi, (5-30 bar)	01 = w man. override shut-off	01 = 75-435 psi, (5-30 bar)	
02 = N/A	02 = 100-380 psi, (7-26 bar)	02 = N/A	02 = 100-380 psi, (7-26 bar)	
	03 = 150-400 psi, (10.3-27.6 bar)		03 = 150-400 psi, (10.3-27.6 bar)	
			04 = 75-250 psi, (5-17.2 bar)	

**Internal pump**

**P11 & P14**  
 0 = 1.07 in<sup>3</sup>/rev., 17.5 cm<sup>3</sup>/rev. servo, same size for repl.  
 x = none

**External drive** 0 = none (A = SAE-A B = SAE-B P Pumps only)

**External mounting** 0 = pump not mounted 1 = pump mounted, -must be separately specified

**Designates special**

**Allowable Controls: P\_P:** 102, 104, 2A2, 2A4, 2H2, 2H4, 402, 4A2, 4A4, 4B2, 4B4, 4C2, 4C4, 5A2, 5A4, 5C2, 5C4, 602, 604, 6B2, 6B4, 7D2, 7E2, 742, 7G2, 8A2, 8A4, 9A2, 9A4

**P\_V:** 102, 104, 2A2, 2A4, 4A2, 4A4, 4C2, 4C4, 5A2, 5A4, 5C2, 5C4, 6A2, 6A4, 6C2, 6C4, 7D2, 7E2, 7F2, 7G2, 8A2, 8A4, 9A2, 9A4

**Definition & Unit**

**Example**

**DISPLACEMENT cm<sup>3</sup>/rev**

1 in<sup>3</sup>/rev = 16.387 cm<sup>3</sup>/rev

40 cm<sup>3</sup>/rev = 2.44 in<sup>3</sup>/rev

**FLOW l/min**

1 gpm = 3.78 l/min

148 l/min = 39.15 GPM

**POWER kW**

1 hp = 0.7457 kW

25 kW = 33.52 hp

**TORQUE Nm**

1 ft-lb = 1.3567 Nm

63 N•m = 46.46 ft-lbs

**PRESSURE bar**

1 psi = 0.069 bar

100 bar = 1450 psi

**WEIGHT kg**

1 lb = 0.455 kg

29 kg = 63.7 lbs

**FORCE N**

1 lb = 1.55 N

600 N = 131.87 lbs

**VOLUME cm<sup>3</sup>**

1 in<sup>3</sup> = 16.387 cm<sup>3</sup>

1000 cm<sup>3</sup> = 61 in<sup>3</sup>

**AREA cm<sup>2</sup>**

1 in<sup>2</sup> = 6.45 cm<sup>2</sup>

50 cm<sup>2</sup> = 7.75 in<sup>2</sup>

**DISTANCE mm**

1 in = 25.4 mm

101.6 mm = 4 in

**TEMPERATURE °C**

Deg. F =  $\frac{9 \times \text{Deg. C}}{5} + 32$

50°C = 122 ° F

**VISCOSITY mm<sup>2</sup>/sec (equivalent to cSt)**

60 SSU = 10 mm<sup>2</sup>/sec

25 mm<sup>2</sup>/sec = 130 SSU

"The product information specifications and descriptions contained in this catalog have been compiled for the use and convenience of our customers from information furnished by the manufacturer, and we cannot and do not accept any responsibility for the accuracy or correctness of any description, calculation, specification or information contained herein. No such description, calculated, specified or information regarding the products being sold has been made part of the basis of the bargain nor has same created or amounted to an express warranty that the products would conform thereto. **We are selling the goods and merchandise illustrated and described in this catalog on an as is basis and disclaim any implied warranty, including any warranty of merchantability or warranty of fitness for any particular purposes whatsoever, with respect to the goods and merchandise sold.** All manufacturer warranties shall be passed on to our customers, but we shall not be responsible for special, indirect, incidental or consequential damages resulting from the use of any of the products or information contained or described in this catalog."

**International Distributors**

**In Europe:**

Cyprus  
Eastern Europe  
The Faroe Islands  
Finland  
Greece  
Iceland  
Norway  
Portugal  
Switzerland  
Turkey

**In Africa:**

Algeria  
Egypt  
Ivory Coast  
Morocco  
Nigeria  
South Africa  
Togo  
Tunisia

**In Middle East:**

Iran  
Israel  
Lebanon  
Pakistan  
Qatar  
Saudi Arabia  
Syria  
United Arab Emirates

**In Far East:**

Indonesia  
Korea  
Malaysia  
New Zealand  
Philippines  
Thailand

**Australia**

DENISON HYDRAULICS Pty. Ltd.  
41-43 St. Hillers Road  
P.O. Box 192  
Auburn, N.S.W. 2144  
Tel. (612) 9646 5200  
Fax (612) 9643 1305  
**Other sales offices:**  
Queensland  
South Wantirna Victoria  
Western Australia

**Austria**

DENISON HYDRAULIK GmbH  
Zweigniederlassung Linz  
Haidbachstraße 69  
A-4061 Pasching  
Tel. (43) 7229 4887  
Fax (43) 7229 63092

**Benelux**

DENISON HYDRAULICS  
BENELUX B. V.  
Pascalstraat 100  
3316 Dordrecht  
Holland  
Tel. (31) 786179 900  
Fax (31) 786175 755

**Canada**

DENISON HYDRAULICS  
CANADA Inc.  
2320 Bristol Circle, Unit 1  
Oakville, ON L6H 5S2  
Tel. (905) 829 5800  
Fax (905) 829 5805  
**Other sales offices:**  
Montreal, QC  
Calgary, AB

**China, P.R.**

DENISON HYDRAULICS Ltd.  
3F, No. 1, Mao Jia Zhai, Bai Lian Jing  
Pudong New Area  
Shanghai 200126,  
Tel. (86) 21 5886 8991  
Fax (86) 21 5886 1978

**Denmark**

DENISON HYDRAULIK  
DENMARK A/S  
Industrikrogen 2  
DK-2635 Ishøj  
Tel. (45) 4371 15 00  
Fax (45) 4371 15 16

**Finland**

DENISON HYDRAULICS  
P.O. Box 36  
FIN-08101 Lohja  
Tel. (358) 208 33 045  
Fax (358) 207 33 045

**France**

DENISON HYDRAULICS  
FRANCE SA  
14, route du Bois Blanc  
BP 539  
18105 Vierzon  
Tel. (33) 2 48 53 01 20  
Fax (33) 2 48 75 02 91  
**Other sales offices:**  
Bordeaux  
Lyon  
Paris

**Germany**

DENISON HYDRAULIK GmbH  
Herderstrasse 26  
D-40721 Hilden  
Tel. (49) 2103 940-6  
Fax (49) 2103 940-880  
**Other sales offices:**  
Dresden  
Hanover  
Stuttgart

**Great Britain**

DENISON HYDRAULICS U.K.  
Ltd.  
Kenmore Road  
Wakefield 41, Industrial Estate  
Wakefield, WF20XE  
West Yorkshire  
England  
Tel. (44) 19 24 826 021  
Fax (44) 19 24 826 146  
**Other sales offices:**  
Burgess Hill

**Hong Kong, N. T.**

DENISON HYDRAULICS Ltd.  
Unit 3, 25/F Wharf Cable Tower  
9 Hoi Shing Road  
Tsuen Wan  
Tel. (852) 24988381  
Fax (852) 24991522

**Italy**

DENISON HYDRAULICS S.r.l.  
Viale Europa 68  
20090 Cusago  
Tel. (39) 2 90 33 01  
Fax (39) 2 90 39 06 94

**Japan**

DENISON JAPAN Inc.  
4-2-1 Tsujido-Shinmachi  
Fujisawa 251,  
Tel. (81) 466 35 3257  
Fax (81) 466 35 2029  
**Other sales office:**  
Osaka

**Mexico, Central America, South**

**America and Caribbean Countries Contact**  
DENISON HYDRAULICS Inc.  
6167 NW 181 Terrace Circle North  
Miami, FL 33015, USA  
Tel. (305) 362 2246  
Fax (305) 362 6220

**Other European, Middle East**

**and African Countries Contact**  
DENISON HYDRAULICS  
FRANCE SA  
14, route du Bois Blanc  
BP 539  
18105 Vierzon Cedex  
France  
Tel. (33) 2 48 53 01 45  
Fax (33) 2 48 53 01 46

**Singapore**

DENISON HYDRAULICS S.E.A.  
Pte. Ltd.  
No. 11 Lorong Tukang Dua  
2261 Singapore  
Tel. (65) 2687840  
Fax (65) 2687847

**Spain**

DENISON HYDRAULICS, S.A.  
Gomis, 1  
08023 Barcelona  
Tel. (34) 3418 46 87  
Fax (34) 3211 65 07  
**Other sales offices:**  
San Sebastian

**Sweden**

DENISON HYDRAULICS  
SVENSKA AB  
Sporregatan 13  
213 77 - Malmö  
Tel. (46) 40 21 04 40  
Fax (46) 40 21 47 26  
**Other sales offices:**  
Spaaga

**Taiwan, R.O.C.**

DENISON HYDRAULICS Ltd.  
6F-10, No. 79, Sec. 2, Roosevelt Road  
Taipei,  
Tel. (886) 2 3645101 / 3645102  
Fax (886) 2 3639025

**USA**

DENISON HYDRAULICS Inc.  
14249 Industrial Parkway  
Marysville, OH 43040  
Tel. 937 644 3915  
Fax 937 642 3738  
For nearest Distributor:  
Call toll free 1 800 551 5956  
**Other sales offices:**  
Fulton, CA  
Mulberry, FL  
Moline, IL  
Rock Island, IL  
Kentwood, MI  
Portland, OR  
Collierville, TN  
Arlington, TX  
Houston, TX

Your local DENISON representative



Internet: <http://www.denisonhydraulics.com>  
E-mail: [denison@denisonhydraulics.com](mailto:denison@denisonhydraulics.com)