

A

R75 Regulator

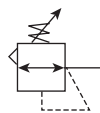

Features

- Compact Size Allows Greater Design Flexibility
- Connects to Other QUBE Units Using Just Screws and O-rings (Included)
- Integral Mounting Slots Eliminate Need for Mounting Brackets
- Diaphragm Operated Design with Balanced Poppet Design for Quick and Accurate Regulation
- Panel Mountable
- High Flow: 1/4" - 25 SCFM[§]
3/8" - 45 SCFM[§]
1/2" - 60 SCFM[§]

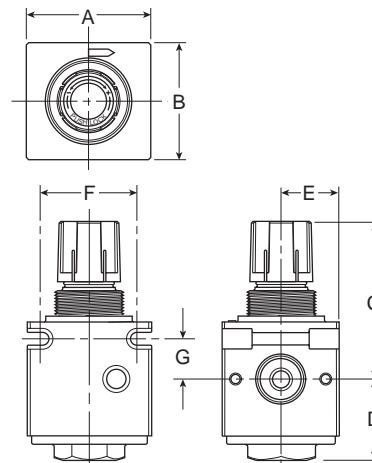

Port Size	NPT	BSPB
	Relieving	Relieving
Without Gauge 0-125 PSIG Reduced Pressure		
1/4"	R75-02C	R75G02C
3/8"	R75-03C	R75G03C
1/2"	R75-04C	R75G04C
With Gauge 0-125 PSIG Reduced Pressure		
1/4"	R75-02CG	—
3/8"	R75-03CG	—
1/2"	R75-04CG	—

R75 Regulator Dimensions						
A	B	C	D	E	F	G
2.19 (55.6)	2.06 (52.4)	2.75 (69.8)	1.38 (34.9)	1.09 (27.8)	1.66 (42.1)	0.69 (17.5)

Inches
(mm)

NOTE: 1.25 Dia. (32mm) hole required for panel mounting.

Bold Items are Most Popular.

For other models refer to ordering information below.

§ SCFM = Standard Cubic Feet Per Minute at 100 PSIG Inlet, 75 PSIG No Flow Secondary Setting, and 20 PSIG Pressure Drop.

Ordering Information

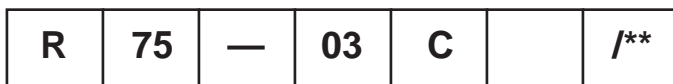

Port Threads
— NPT
G BSPP

Port Size
02 1/4"
03 3/8"
04 1/2"

Reduced Pressure Range
A 0-25 PSIG
B 0-60 PSIG
C 0-125 PSIG

Options
G Gauge
K Non-relieving
P Panel Mount Nut (Plastic)
T Tamperproof Adjustment

Engineering Change Designator
Will be entered at factory.

BOLD ITEMS ARE MOST POPULAR.



Technical Information

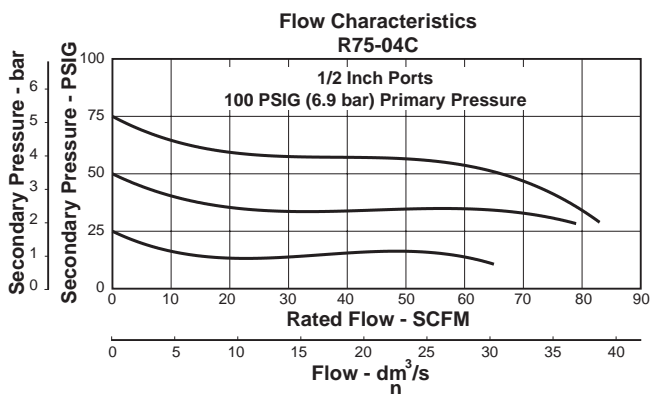
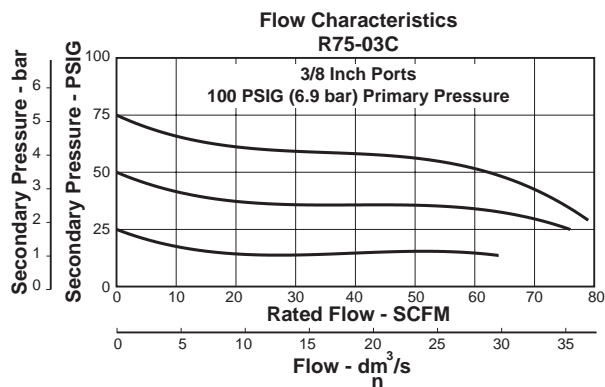
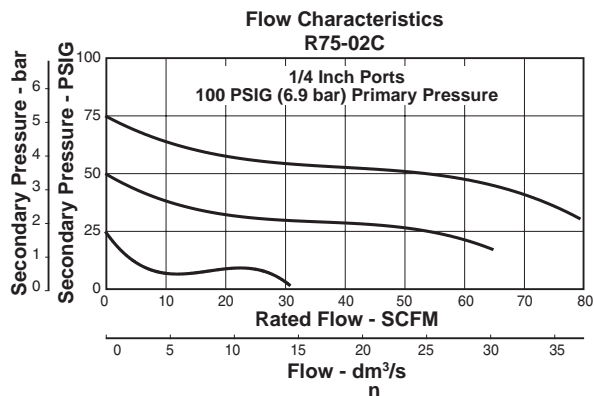

⚠ WARNING

**Product rupture can cause serious injury.
 Do not connect regulator to bottled gas.
 Do not exceed maximum primary pressure rating.**

⚠ CAUTION:

REGULATOR PRESSURE ADJUSTMENT – The working range of knob adjustment is designed to permit outlet pressures within their full range. Pressure adjustment beyond this range is also possible because the knob is not a limiting device. This is a common characteristic of most industrial regulators, and limiting devices may be obtained only by special design. For best performance, regulated pressure should always be set by increasing the pressure up to the desired setting.

R75 Regulator Kits & Accessories

- Cage Kits**–
 - StandardCKR75
 - TamperproofCKR75T
- Control Knob** R35-0545P
- Gauges** –
 - 1-1/2" Dial Size, 1/8" Back Connection
 0 to 60 PSIG (0 to 4 bar) K4515N18060
 - 1-1/2" Dial Size, 1/8" Back Connection
 0 to 160 PSIG (0 to 11 bar) K4515N18160
- Panel Mounting Bracket Kit** SA161X57
- Face Mounting Bracket Kit (See Page A66)** SAR75Y57
- Panel Mount Nut** –
 - PlasticR05X51-P
 - AluminumR05X51-A
- Repair Kits** –
 - Non-Relieving Diaphragm, Valve Assembly RKR75K
 - Relieving Diaphragm, Valve AssemblyRKR75

Specifications

- Gauge Ports (2)**1/8 Inch
- Port Threads** 1/4, 3/8 & 1/2 Inch
- Supply Pressure**300 PSIG Max. (20,4 bar)
- Temperature Rating**40°F to 125°F (4.4°C to 52°C)
- Weight** 1.35 lbs. (.61 kg) / unit
 27 lbs. (12.24 kg) / 20-Unit Master Pack

Materials of Construction

- Adjusting Knob** Acetal
- Body**Zinc
- Bottom Plug** Glass-Filled Acetal
- Cage** Glass-Filled Acetal
- Elastomers** Buna N

