

General Description

Series R5P direct operated, 3-way pressure compensators can be combined with any type of fixed or adjustable flow resistor (throttle) to provide a load compensated flow. The combination with the proportional throttle valve F5C serves as a compact 3-way flow control unit in SAE flange design. The R5P is typically used as meter-in compensator in front of the flow resistor.

The R5P is additionally equipped with a pressure relief pilot that controls the compensator cartridge and operates a system pressure relief valve. The R5P*P2 provides a proportional relief function.

Features

- Seated type 3-way pressure compensator.
- SAE 61 flange.
- 8.4 Bar (121.8 PSI) control pressure.
- Pressure relief function (optionally proportional).
- With optional vent function.
- 3 sizes (SAE Code 61 3/4", 1", 1-1/4").
- Load compensated flow in combination with F5C.

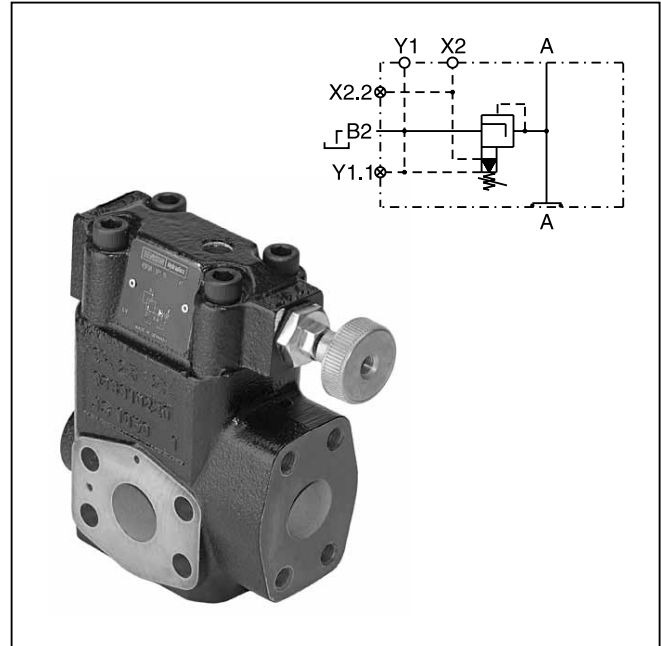

B

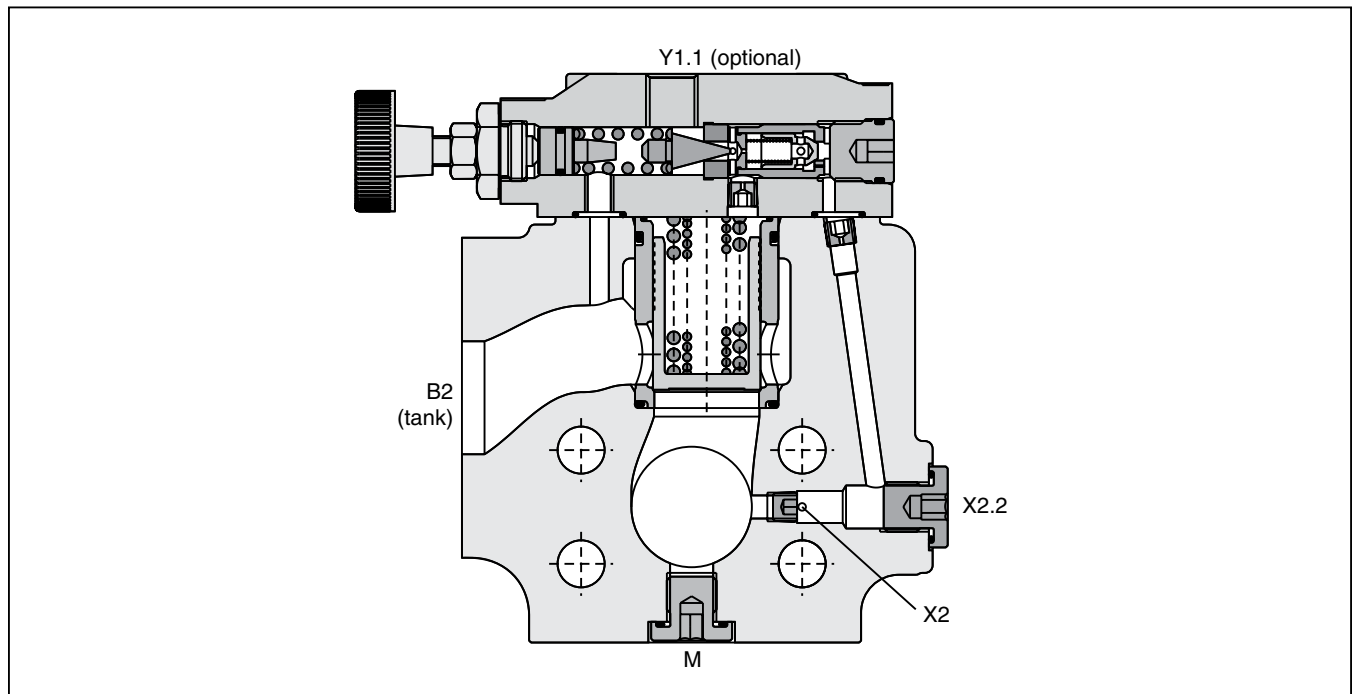

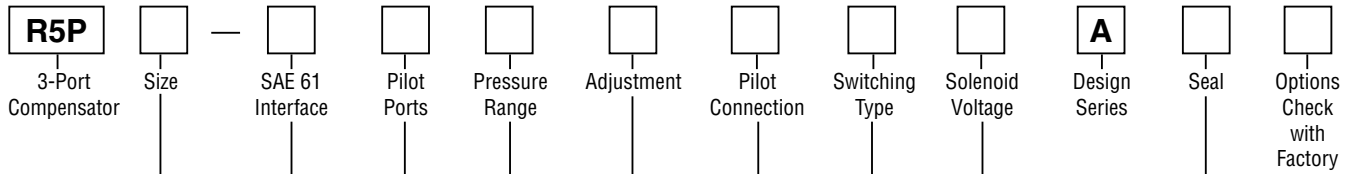

B

Code	Description
06	SAE 3/4"
08	SAE 1"
10	SAE 1-1/4"

Code	Size	Max. Pressure
4	10	280 Bar (4060 PSI)
5	06/08	350 Bar (5075 PSI)

Code	Pilot Port	Port Y1*
3	SAE	Plugged
S	SAE	Open

* Y1 port is used in combination with F5C, when the F5C should be drained through the R5P (internal or external drain).

Code	Description
1	Hand Knob
3	Acorn Nut with Lead Seal

Code	Description
2	Internal PD Internal PP*
6	External PD** Internal PP*

* PP through port X1 in outlet flange.
 ** Through port Y1.1.

Code	Description
Omit	Standard w/o vent function
G0R	12 VDC
G0Q	24 VDC
G0H	48 VDC
GAR	98 VDC
W30	110V 50Hz/ 120V 60Hz
W31	220V 50Hz/ 240V 60Hz

Code	Description
Omit	Standard w/o vent function
09*	Solenoid not activated unload circulation
11**	Solenoid activated unload circulation

* Solenoid de-energized: open to tank
 solenoid energized: vent line blocked.
 ** Solenoid de-energized: vent line blocked
 solenoid energized: open to tank.

Code	Description*
1	Nitrile
5	Fluorocarbon

* Further seals on request.

Code	Description
1	7 to 105 Bar (102 to 1523 PSI)
3	7 to 210 Bar (102 to 3045 PSI)
5	7 to 350 Bar (102 to 5075 Bar)

Weight:	R5P	R5P with VV01
R5P06	3.7 kg (8.2 lbs.)	5.4 kg (11.9 lbs.)
R5P08	4.4 kg (9.7 lbs.)	6.1 kg (13.5 lbs.)
R5P10	5.3 kg (11.7 lbs.)	7.0 kg (15.4 lbs.)

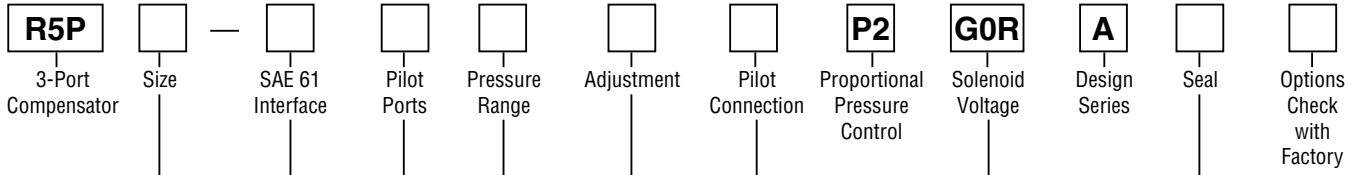

Code	Description
06	SAE ¾"
08	SAE 1"
10	SAE 1¼"

Code	Description
1	Hand knob
3	Acorn nut with lead seal

Code	Description
G0R	12V, 2.3A

Code	Description
1	Nitrile
5	Fluorocarbon

Further seals on request

Code	Size	Max. Pressure
4	10	280 Bar (4060 PSI)
5	06/08	350 Bar (5075 PSI)

Code	Description
2	Internal PD Internal PP ⁴⁾
6	External PD ³⁾ Internal PP ⁴⁾

³⁾ Through port Y1.1
⁴⁾ PP through port X1 in outlet flange

Code	Pilot Ports	Port Y1 ¹⁾
3	SAE	Plugged
S	SAE	Open

¹⁾ Y1 port is used in combination with F5C, when the F5C should be drained through the R5P (internal or external drain)

Code	Description
1	7 to 105 Bar (102 to 1523 PSI)
3	7 to 210 Bar (102 to 3045 PSI)
5 ²⁾	7 to 350 Bar (102 to 5075 Bar)

²⁾ R5P10-4*5 up to 280 Bar (4060 PSI)

Weight:	R5P*P2
R5P06*P2	5.5 kg (12.1 lbs.)
R5P08*P2	6.2 kg (13.7 lbs.)
R5P10*P2	7.1 kg (15.7 lbs.)



B

R5P

General								
Size			06 (3/4")		08 (1")		10 (1 1/4")	
Mounting	Flanged according to SAE 61							
Mounting Position	Unrestricted							
Ambient Temperature Range	-20°C to +50°C (-4°F to +122°F)							
MTTF _D	150 years							
Hydraulic								
Max. Operating Pressure	Ports A, B	350 Bar (5075 PSI)		350 Bar (5075 PSI)		280 Bar (4060 PSI)		
Pressure Ranges	105 Bar (1523 PSI), 210 Bar (3045 PSI), 350 Bar (5075 PSI)							
Nominal Flow	90 LPM (23.8 GPM)		300 LPM (79.4 GPM)		600 LPM (158.7 GPM)			
Fluid	Hydraulic oil as per DIN 51524...51535, other on request							
Fluid Temperature	-20°C to +80°C (-4°F to +176°F)							
Viscosity	Permitted	10 to 650 cSt / mm ² /s (46 to 3013 SSU)						
	Recommended	30 to 80 cSt / mm ² /s (139 to 371 SSU)						
Filtration	ISO Class 4406 (1999) 18/16/13 (acc. NAS 1638: 7)							
Electrical (Solenoid) R5P with VV01								
Duty Ratio	100% ED; CAUTION: Coil temperature up to 150°C (302°F) possible							
Solenoid Connection	Connector as per EN175301-803							
Protection Class	IP65 in accordance with EN60529 (plugged and mounted)							
	Code	G0R	G0Q	GAR	GOH	W30	W31	
Supply Voltage		12 VDC	24 VDC	98 VDC	48 VDC	110V at 50Hz 120V at 60Hz	230V at 50Hz 240V at 60Hz	
Tolerance Supply Voltage	[%]	±10	±10	±10	±10	±5	±5	
Power Consumption	Hold	[W]	32.7	31	32	30	70 / 70 VA	
	In Rush	[W]	32.7	31	32	30	280 / 290 VA	
Response Time	Energized / De-energized AC 20/18ms, DC 46/27 ms							
Maximum Switching Frequency	AC up to 7200, DC 70 to 16,000 switchings/hour							
Coil Insulation Class	H (180°C) (356°F)							

R5P*P2 (Proportional)

General								
Size			06 (3/4")		08 (1")		10 (1-1/4")	
Mounting	Flanged according to SAE 61							
Mounting Position	Unrestricted							
Ambient Temperature Range	-20°C to +50°C (-4°F to +122°F)							
MTTF _D	150 years							
Hydraulic								
Max. Operating Pressure	Ports A, B	350 Bar (5075 PSI)		350 Bar (5075 PSI)		280 Bar (4060 PSI)		
Pressure Range	105 Bar (1523 PSI), 210 Bar (3045 PSI), 350 Bar (5075 PSI)							
Nominal Flow	90 LPM (23.8 GPM)		300 LPM (79.4 GPM)		600 LPM (158.7 GPM)			
Fluid	Hydraulic oil as per DIN 51524...51535, other on request							
Fluid Temperature	-20°C to +80°C (-4°F to +176°F)							
Viscosity	Permitted	10 to 380 cSt / mm ² /s (46 to 1761 SSU)						
	Recommended	30 to 80 cSt / mm ² /s (139 to 371 SSU)						
Filtration	ISO Class 4406 (1999) 18/16/13 (acc. NAS 1638: 7)							
Electrical (Solenoid) R5P with VV01								
Duty Ratio	100% ED; CAUTION: Coil temperature up to 150°C (302°F) possible							
Nominal Voltage	12 VDC							
Maximum Current	2.3 A							
Coil Resistance	4 Ohm at 20°C (68°F)							
Solenoid Connection	Connector as per EN175301-803, Solenoid identification as per ISO 9461							
Protection Class	IP65 in accordance with EN60529 (plugged and mounted)							
Power Amplifier	PCD00A-400							

Dimensions

**Pressure Compensator Valves
Series R5P (SAE Flange Mounted)**

Return to
ALPHA
TOC

Return to
SECTION
TOC

Inch equivalents for millimeter dimensions are shown in (**)

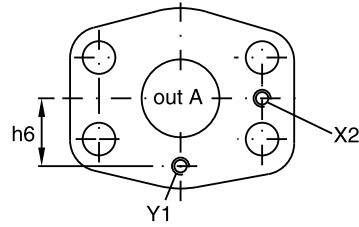
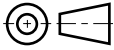

Seal Kits*		
Size	Nitrile	Fluorocarbon
06	S16-91461-0	S16-91461-5
08	S16-91460-0	S16-91460-5
10	S16-91459-0	S16-91459-5

* Does not include P2 seal kit.

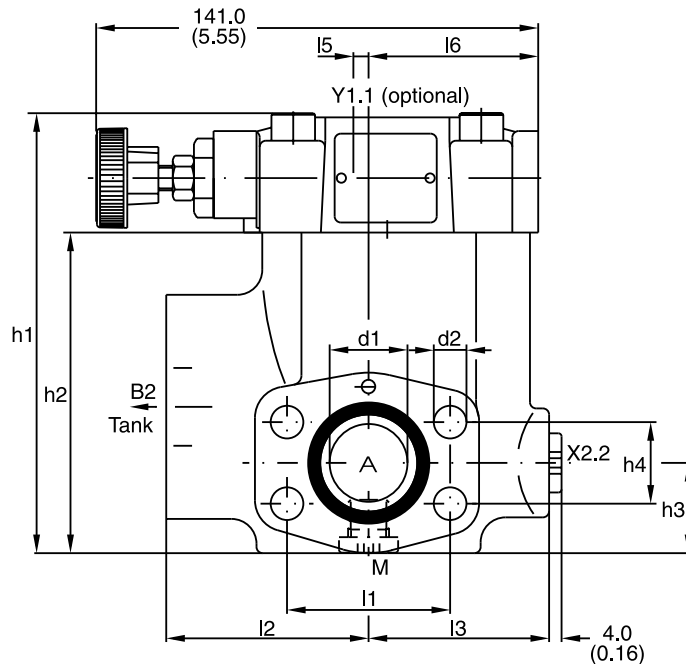
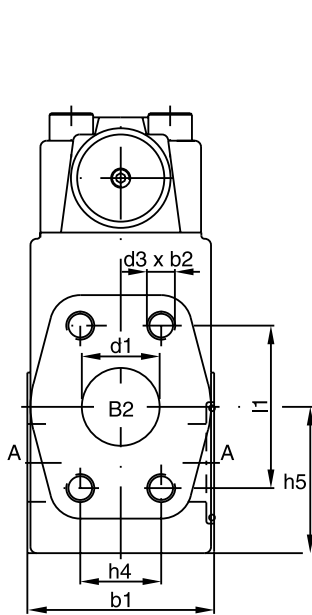
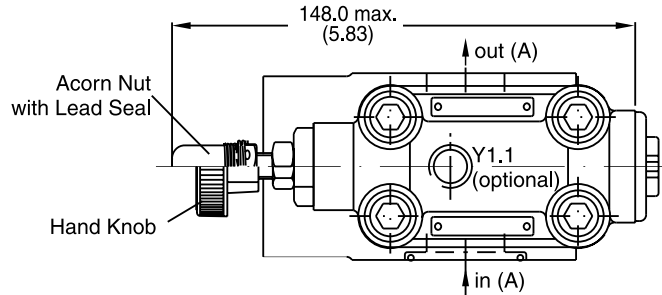

Size	l1	l2	l3	l4	l5	l6	b1	b2	h1	h2	h3	h4	h5	h6	d1	d2	d3
06	47.6 (1.87)	63.0 (2.48)	56.0 (2.20)	148.0 (5.83)	1.0 (0.04)	49.0 (1.93)	60.0 (2.36)	20.0 (0.79)	119.0 (4.69)	81.6 (3.21)	28.5 (1.13)	22.2 (0.87)	41.6 (1.64)	20.8 (0.82)	19.0 (0.75)	10.5 (0.41)	3/8" UNC
08	52.4 (2.06)	65.0 (2.56)	58.0 (2.28)	144.6 (5.69)	5.0 (0.20)	54.5 (2.15)	60.0 (2.36)	23.0 (0.91)	142.0 (5.59)	103.0 (4.06)	30.5 (1.20)	26.2 (1.03)	48.6 (1.91)	24.3 (0.96)	25.0 (0.98)	10.5 (0.41)	3/8" UNC
10	58.7 (2.31)	61.0 (2.40)	62.0 (2.44)	146.6 (5.77)	3.0 (0.12)	56.5 (2.22)	75.0 (2.95)	22.0 (0.87)	149.0 (5.87)	111.5 (4.39)	37.5 (1.48)	30.2 (1.19)	64.1 (2.52)	29.3 (1.15)	32.0 (1.26)	12.5 (0.49)	7/16" UNC

Port	Function	Port size		
		R5P06	R5P08	R5P10
A	Inlet/Outlet	3/4"	1"	1-1/4"
B2	Tank	3/4"	1"	1-1/4"
X2	Internal Pilot Pressure	M3		
X2.2	External Pilot Pressure	G1/4"		
Y1	Internal Pilot Drain	M3		
Y1.1	External Pilot Drain	G1/4"		
M	Pressure Gauge	G1/4"		

R5P.indd, ddp



B107

Parker Hannifin Corporation
Hydraulic Valve Division
Elyria, Ohio, USA

www.comoso.com

B

R5P with Vent Function

Inch equivalents for millimeter dimensions are shown in (**)

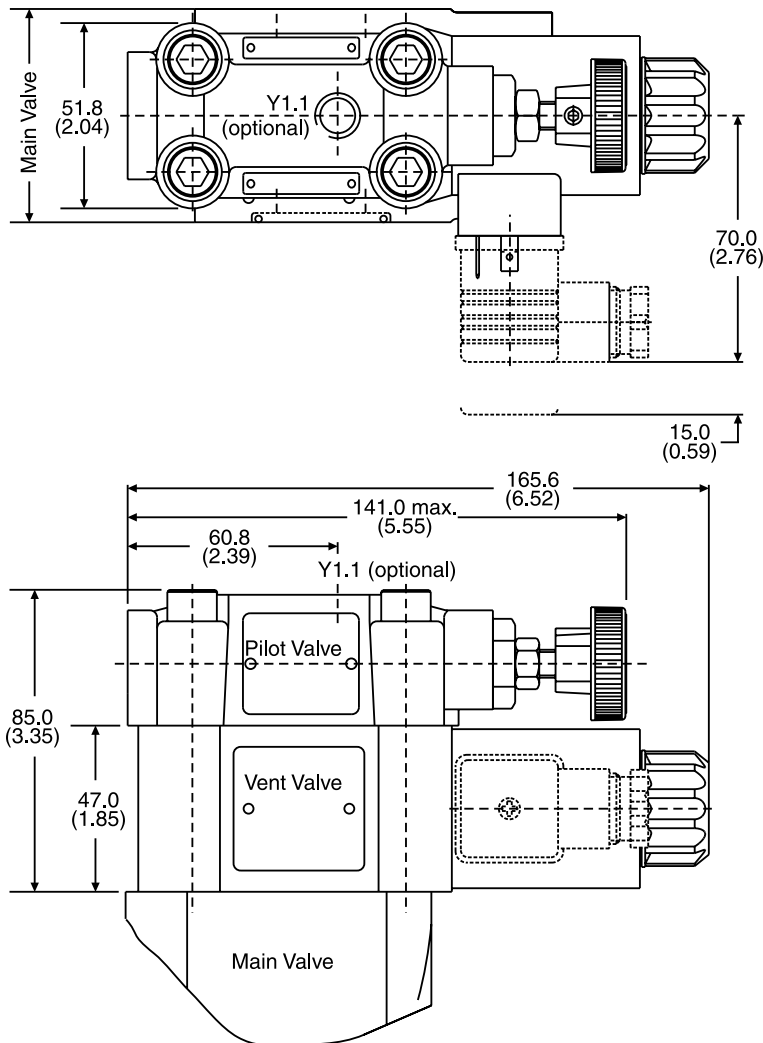

Seal Kits*	
Nitrile	Fluorocarbon
DC solenoid	
S26-58515-0	S26-58515-5
AC solenoid	
S26-35237-0	S26-35237-5

* For vent valve only.

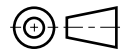

Code	Internal Drain	External Drain
11		
09		

R5P.indd, ddp

