



aerospace  
climate control  
electromechanical  
filtration  
fluid & gas handling  
hydraulics  
pneumatics  
process control  
sealing & shielding



## PV Series Gearheads:

Power and Versatility in an Economical Package

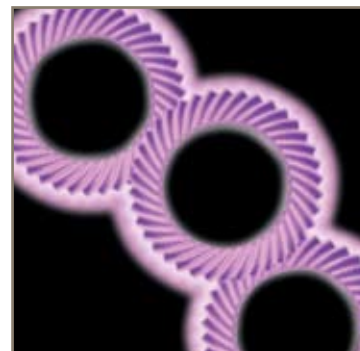

ENGINEERING YOUR SUCCESS.

[www.comoso.com](http://www.comoso.com)

# Parker Hannifin Corporation

A Fortune 300 company with annual sales exceeding \$10 billion and more than 400,000 customers in 43 countries, Parker Hannifin is the world's leading supplier of innovative motion control components and system solutions serving the industrial, mobile, and aerospace markets. We are the only manufacturer offering customers a choice of electromechanical, hydraulic, pneumatic, or computer-controlled motion systems.

## Total System Solutions

Parker's team of highly qualified application engineers, product development engineers, and system specialists can turn pneumatic, structural, and electromechanical products into an integrated system solution. Moreover, our Selectable Levels of Integration™ allows you to choose the appropriate system, subsystem, or component to meet your specific need.

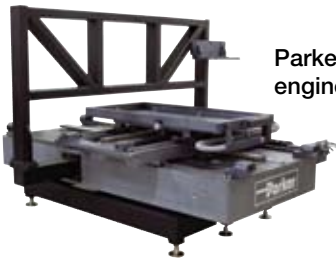

Parker offers complete engineered systems.

## First in Delivery, Distribution, and Support

In today's competitive, fast-moving economy, what good is an application that isn't ready on time? This is especially true when compressed design cycles make the quick delivery of critical components essential. With factories strategically located on five continents, Parker offers an unrivaled delivery record, getting solutions out our door and onto your floor faster than ever.

Parker also has the industry's largest global distribution network, with more than 8,600 distributors worldwide. Each of these locations maintains ample product inventory to keep your downtime to a minimum. And many distributors have in-house design capabilities to support your system and subsystem requirements.

Throughout the design process, Parker's factory-trained electromechanical engineers work hand in hand with you and day or night at 1-800-C-Parker. Our operators will connect you with a live, on-call representative who will identify replacement parts or services for all motion technologies.



© Copyright 2009, Parker Hannifin Corporation. All rights reserved.



Parker world headquarters in Cleveland



## Training

Parker's best-in-class technology training includes hands-on classes, Web-based instruction, and comprehensive texts for employees, distributors, and customers. Parker

also provides computer-based training, PowerPoint presentations, exams, drafting and simulation software, and trainer stands.

## parkermotion.com

Our award-winning Web site is your single source for

- Product information
- Downloadable catalogs
- Motion-sizing software
- 3D design files
- Training materials
- Product-configuration software
- RFQ capabilities
- Videos and application stories



## 24/7 Emergency Breakdown Support

The Parker product information center is available any time of the day or night at 1-800-C-Parker. Our operators will connect you with a live, on-call representative who will identify replacement parts or services for all motion technologies.



# PV = Power + Versatility

## PV Series: Value Alternative Precision Planetary Gearheads



The PV Series planetary gearhead combines power and versatility in an economical package. It comes in a wide range of options, including dimensional output face crossovers to the Parker PX, Alpha LP, Neugart PLE, Stober PE and standard NEMA gearheads.

The PV Series is available in metric or NEMA frame sizes: 40, 60, 90 and 115 mm, and NEMA sizes 17, 23, 34 and 42. Ratios are available from 3:1 to 100:1.

Whether you're an OEM or an end user searching for competitive alternatives, the PV offers a superior solution. Parker's PV Series gearheads are made in the USA.

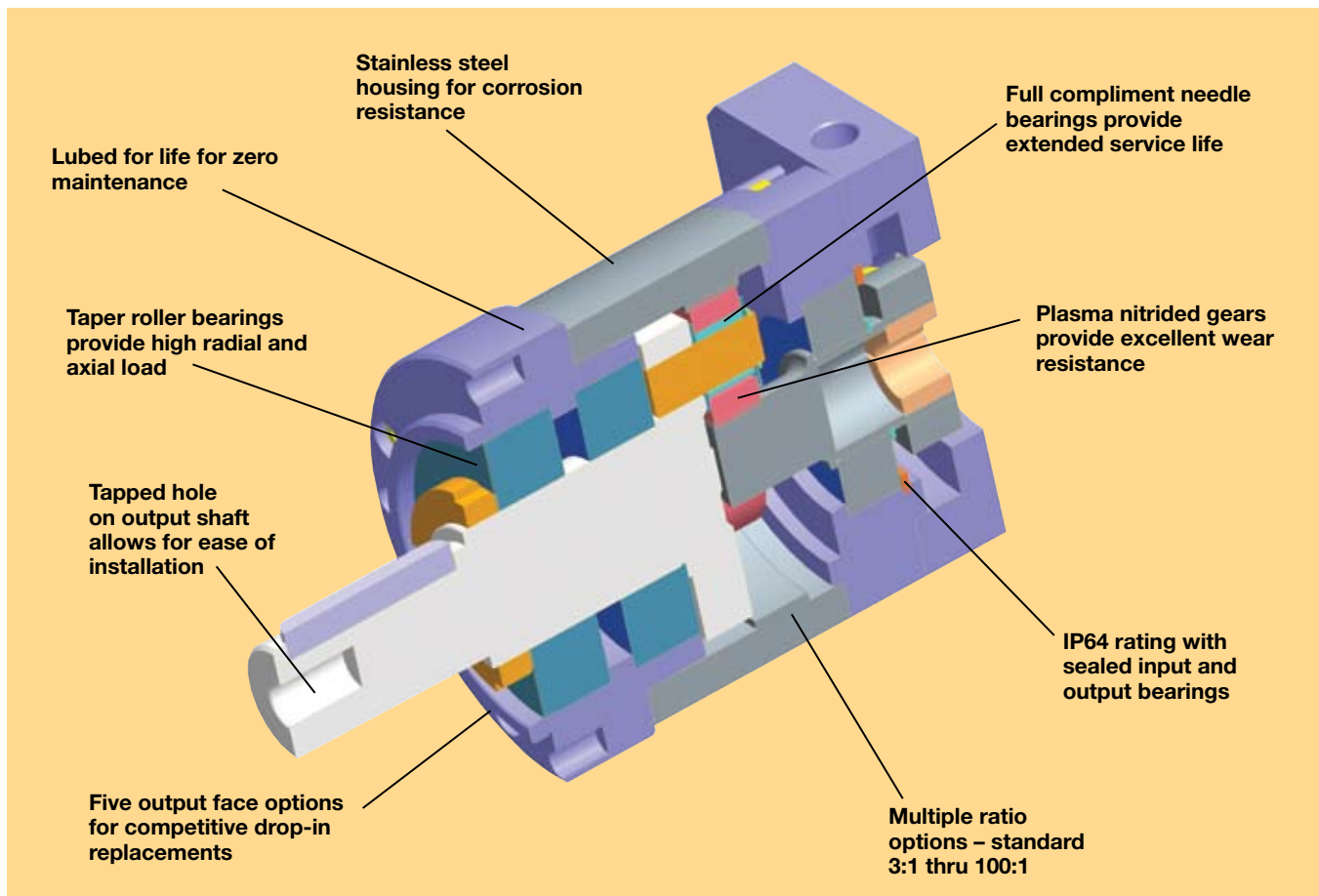

Performance Specifications

Parameter	Units	Ratio	PV40/PV17	PV60/PV23	PV90/PV34	PV115/PV42
<b>Nominal Output Torque</b> $T_{nom r}$	Nm (in-lb)	3	– –	12.0 (106.200)	35 (309.75)	74 (654.90)
		4	5.9 (52.215)	18.9 (167.265)	56 (495.60)	111 (982.30)
		5	6.2 (54.870)	19.6 (173.460)	58 (513.30)	115 (1017.70)
		7	5.5 (48.675)	16.7 (147.795)	52 (460.20)	104 (920.40)
		10	3.5 (30.975)	10.6 (93.810)	33 (292.05)	67 (592.95)
		12	– –	18.2 (161.070)	54 (477.90)	112 (991.20)
		15	– –	19.4 (171.690)	58 (513.30)	120 (1062.00)
		16	6.5 (57.525)	– –	– –	– –
		20	6.5 (57.525)	21.5 (190.275)	67 (592.95)	136 (1203.60)
		25	6.7 (59.295)	20.0 (177.000)	63 (557.55)	126 (1115.10)
		30	– –	22.5 (199.275)	71 (628.35)	144 (1274.40)
		35	6.7 (59.295)	– –	– –	– –
		40	6.5 (57.525)	21.5 (190.275)	67 (592.95)	136 (1203.60)
		50	6.7 (59.295)	20.0 (177.000)	63 (557.55)	126 (1115.10)
		<b>Maximum Acceleration Output Torque</b> <sup>1)</sup> $T_{acc r}$	Nm (in-lb)	3	– –	24.0 (212.400)
4, 5, 12, 15	11.8 (104.430)			36.4 (322.140)	108 (955.80)	222 (1964.70)
7, 70	11.0 (97.350)			33.4 (295.590)	104 (920.40)	208 (1840.80)
10, 100	7.0 (61.950)			21.2 (187.620)	66 (584.10)	134 (1185.90)
16, 20, 25, 30, 35, 40, 50	13.0 (115.050)			40.0 (354.000)	126 (1115.10)	252 (2230.20)
<b>Emergency Stop Output Torque</b> <sup>2)</sup> $T_{em r}$	Nm (in-lb)			3, 4, 5, 12, 15, 16, 20, 25, 30, 35, 40, 50	16.0 (141.600)	55.0 (486.750)
		7, 70	13.7 (121.245)	44.0 (389.400)	137 (1212.45)	290 (2466.50)
		10, 100	9.2 (81.420)	39.0 (345.150)	122 (1079.70)	255 (2256.75)
<b>Nominal Input Speed</b> $N_{nom r}$	RPM	3 – 100	4500	4000	3500	3000
<b>Maximum Input Speed</b> $N_{max r}$	RPM	3 – 100	8000	6000	6000	5000
<b>Service Life</b>	h	3 – 100	20,000			
<b>Standard Backlash</b> <sup>3)</sup>	arc-min	3 – 10	<15	<12	<10	<8
		15 – 100	<18	<16	<14	<12
<b>Efficiency at Nominal Torque</b>	%	3 – 10	96			
		15 – 100	94			
<b>Noise Level at 3000 RPM</b> <sup>4)</sup>	db	3 – 100	<60	<65	<65	<70
<b>Maximum Allowable Case Temperature</b>	° C	3 – 100	-20 to 100			
<b>Lubrication</b>		3 – 100	Lifetime lubrication			
<b>Mounting Position</b>		3 – 100	Any			
<b>Direction of Rotation</b>		3 – 100	Same as Input			
<b>Degree of Protection</b>		3 – 100	IP64			
<b>Maximum Weight</b>	kg (lbs)	3 – 10	0.6 (1.2)	1.2 (2.5)	3.2 (7.0)	6.8 (13.5)
		15 – 100	0.9 (2.0)	1.6 (3.5)	4.3 (9.5)	9.7 (19.3)

1)  $t_{acc} + t_{dec} = 0.2 (t_{acc} + t_{cont} + t_{dec})$   $T_{cont} = 0.25 T_{acc}$

2) Maximum of 1000 stops.

3) Measured at 2% of rated torque.

4) Measure at 1m. r = rated values







## Inertia

All moment of inertia values are as reflected at the input of the gearhead

Ratio	Units*	PV40/PV17	PV60/PV23	PV90/PV34	PV115/PV42
3	kg-cm <sup>2</sup>	–	0.1400	0.7400	1.9700
	in-lb-sec <sup>2</sup>	–	0.000124	0.000655	0.001743
4	kg-cm <sup>2</sup>	0.0200	0.1000	0.5000	1.3400
	in-lb-sec <sup>2</sup>	0.000018	0.000089	0.000443	0.001186
5	kg-cm <sup>2</sup>	0.0180	0.0840	0.3900	1.1300
	in-lb-sec <sup>2</sup>	0.000016	0.000074	0.000345	0.001000
7	kg-cm <sup>2</sup>	0.0160	0.0750	0.3400	0.9300
	in-lb-sec <sup>2</sup>	0.000014	0.000066	0.000301	0.000823
10	kg-cm <sup>2</sup>	0.0160	0.0070	0.3000	0.8500
	in-lb-sec <sup>2</sup>	0.000014	0.000006	0.000266	0.000752
12	kg-cm <sup>2</sup>	–	0.0970	0.4900	1.2300
	in-lb-sec <sup>2</sup>	–	0.000086	0.000434	0.001089
15	kg-cm <sup>2</sup>	–	0.0830	0.3900	1.0400
	in-lb-sec <sup>2</sup>	–	0.000073	0.000345	0.000920
16	kg-cm <sup>2</sup>	0.0190	–	–	–
	in-lb-sec <sup>2</sup>	0.000017	–	–	–
20	kg-cm <sup>2</sup>	0.0170	0.0830	0.3900	1.0400
	in-lb-sec <sup>2</sup>	0.000015	0.000073	0.000345	0.000920
25	kg-cm <sup>2</sup>	0.0170	0.0830	0.3900	1.0400
	in-lb-sec <sup>2</sup>	0.000015	0.000073	0.000345	0.000920
30	kg-cm <sup>2</sup>	–	0.0700	0.3000	0.8400
	in-lb-sec <sup>2</sup>	–	0.000062	0.000266	0.000743
35	kg-cm <sup>2</sup>	0.0160	–	–	–
	in-lb-sec <sup>2</sup>	0.000014	–	–	–
40, 50, 70, 100	kg-cm <sup>2</sup>	0.0160	0.0700	0.3000	0.8400
	in-lb-sec <sup>2</sup>	0.000014	0.000062	0.000266	0.000743

\* Note: 1 kg-cm<sup>2</sup> = 0.000885 in-lb-sec<sup>2</sup>

## Maximum Output Shaft Load Rating

See load rating charts on pages 6-7

	Output Face Option*	PV40/PV17	PV60/PV23	PV90/PV34	PV115/PV42
Maximum Radial Load Pr, N ** (3-100 ratios)	FE	200	665	1040	1235
	TN	440	665	1040	2100
	FB, FN, TA	590	2535	4270	8550
Maximum Axial Load Pr, N ** (3-100 ratios)	FE	190	765	1140	1300
	TN	430	765	1140	2380
	FB, FN, TA	530	2350	4670	10550

\* See How to Order page 10, items 3 & 4 for front face/output face code definitions. \*\* @100 rpm, radial load applied at center of shaft

## Output Shaft Load Ratings – PV40/PV17 & PV60/PV23

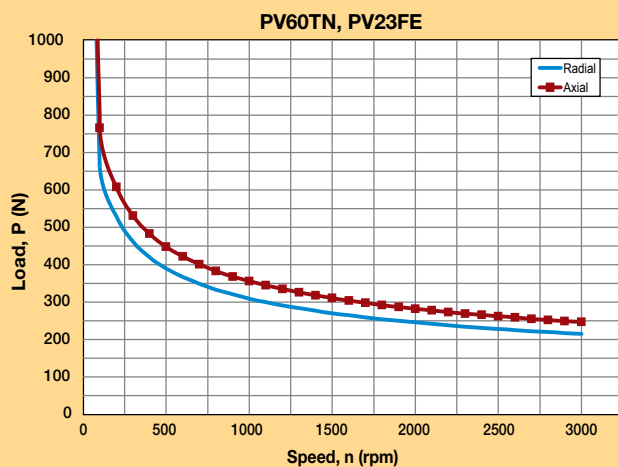
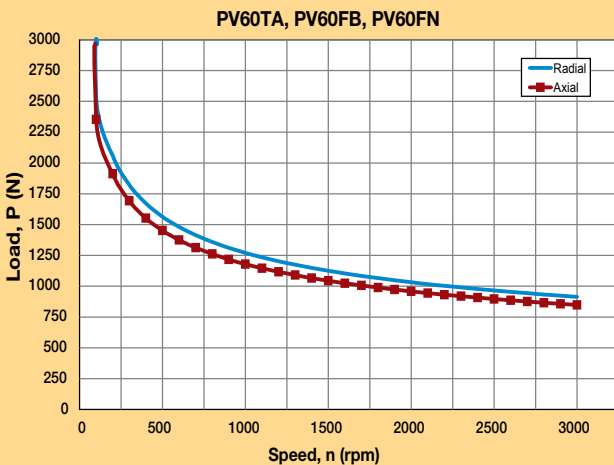
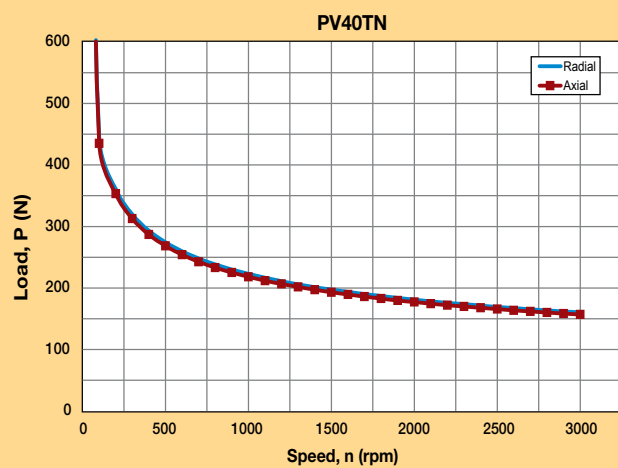
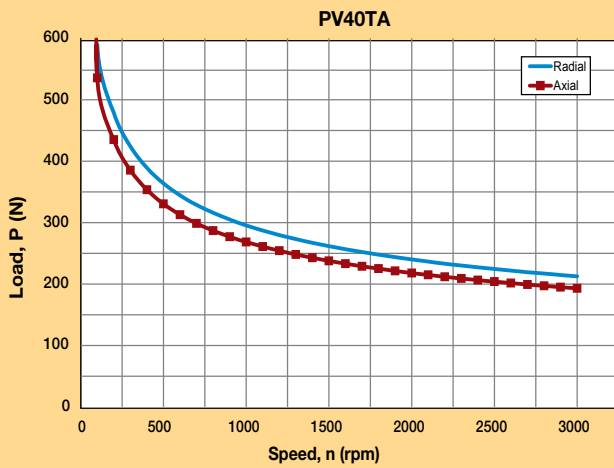
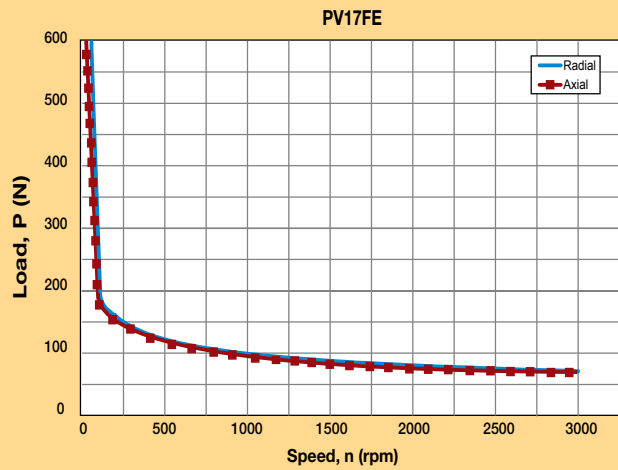
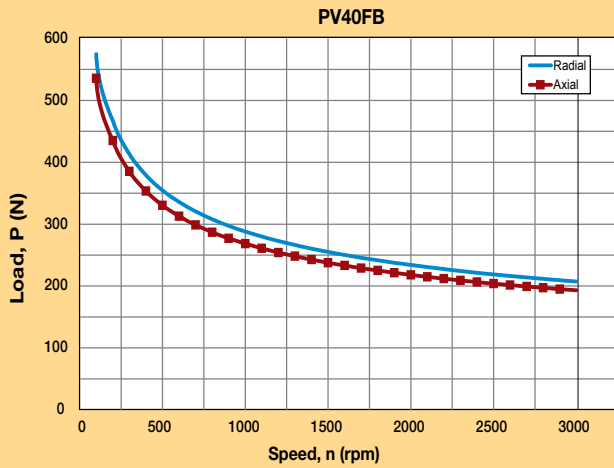

See How to Order page 10, items 3 & 4 for front face/output face code definitions.

- 1) Maximum axial load,  $F_a$ .
- 2) Maximum radial load applied to the center of the shaft,  $F_r$ .
- 3) Radial load curves can be used to combine (radial + axial) load if  $F_a/F_r < 0.22$ .
- 4) If  $F_a/F_r > 0.22$  consult factory.



## Output Shaft Load Ratings – PV90/PV34 & PV115/PV42

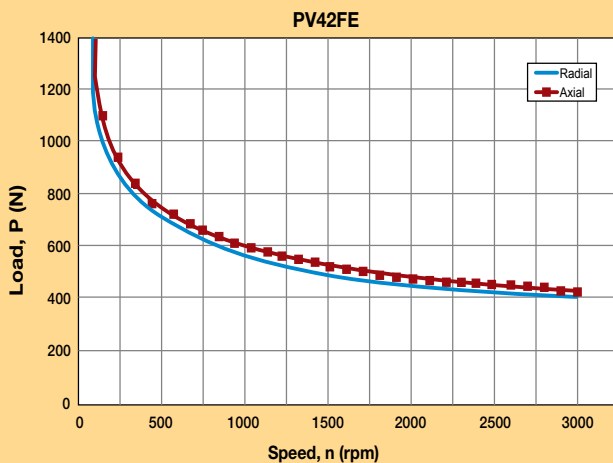
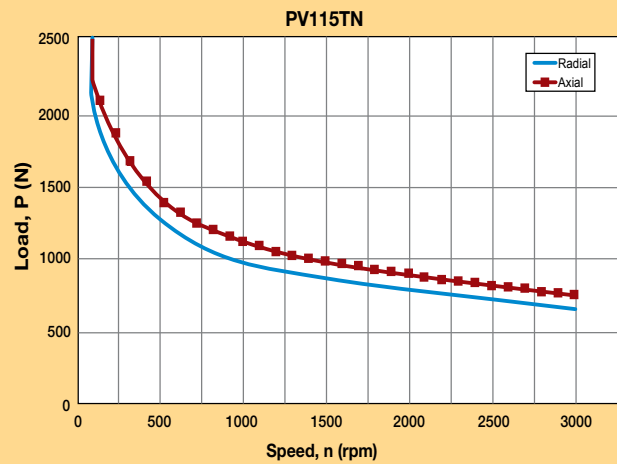
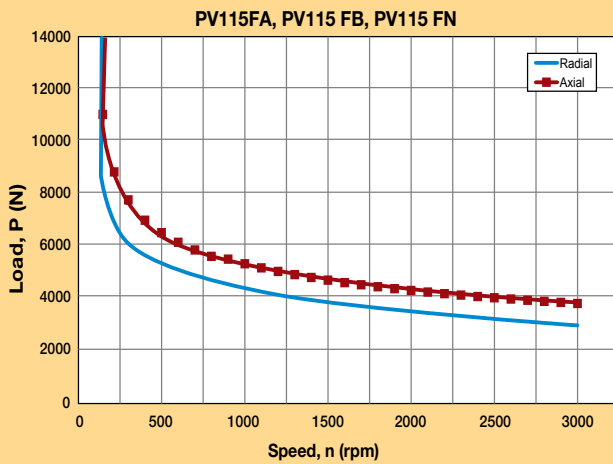
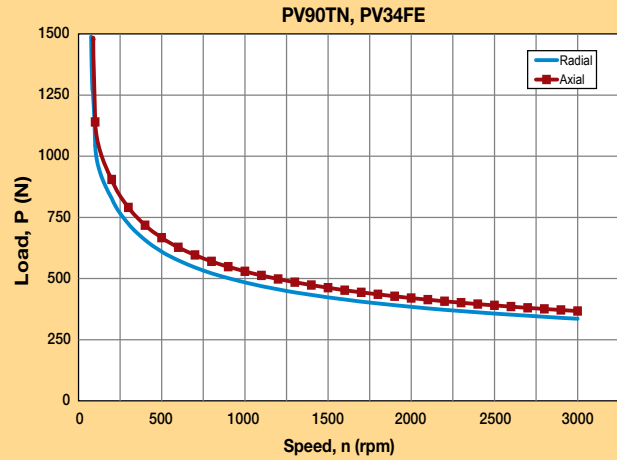
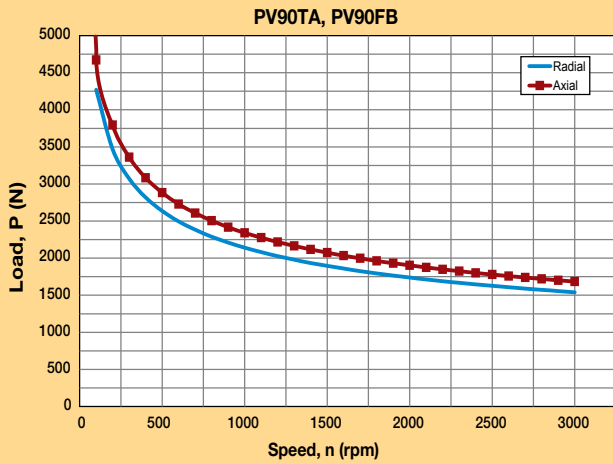

See How to Order page 10, items 3 & 4 for front face/output face code definitions.

- 1) Maximum axial load,  $F_a$ .
- 2) Maximum radial load applied to the center of the shaft,  $F_r$ .
- 3) Radial load curves can be used to combine (radial + axial) load if  $F_a/F_r < 0.22$ .
- 4) If  $F_a/F_r > 0.22$  consult factory.

## Dimensions – Tapped Face (TA & TN)

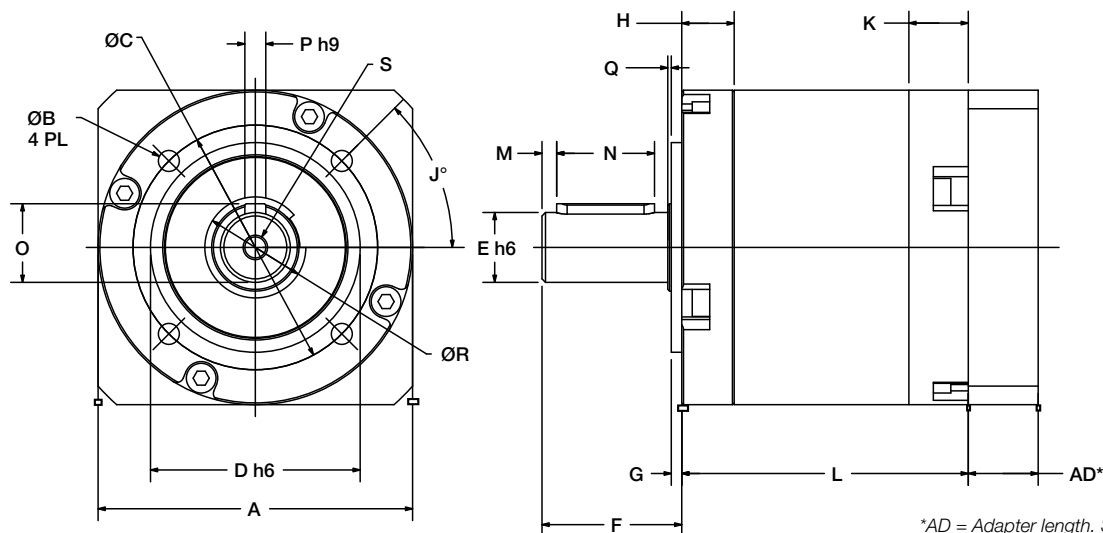

\*AD = Adapter length. See how to order page for mounting kit adapter lengths.

### Metric Frame Sizes

Frame Size	A		B		C		D		E		F		G		H		J	K	
	mm	in	mm	in	mm	in	mm	in	mm	in	mm	in	mm	in	mm	in	°	mm	in
PV40TN	43	1.693	M4x7	34	1.339	26	1.024	10	0.394	26	1.024	1.5	0.059	10	0.394	45	11	0.433	
PV40TA	50	1.969	M4x10	44	1.732	35	1.378	12	0.472	25	0.984	3	0.118	10	0.394	90	11	0.433	
PV60TN	62	2.441	M5x10	52	2.047	40	1.575	14	0.551	35	1.378	2.5	0.098	12	0.472	45	16	0.630	
PV60TA	70	2.756	M5x10	62	2.362	52	2.047	16	0.630	36	1.417	5	0.197	16	0.630	90	16	0.630	
PV90TN	90	3.543	M6x11	70	2.756	60	2.362	20	0.787	40	1.575	3	0.118	15	0.591	45	17	0.670	
PV90TA	90	3.543	M6x12	80	3.150	68	2.677	22	0.866	46	1.811	5	0.197	18.5	0.728	90	17	0.670	
PV115TN	115	4.528	M10x16	100	3.937	80	3.150	25	0.984	55	2.165	4	0.157	20	0.787	45	23	0.906	
PV115TA	120	4.724	M8x20	108	4.252	90	3.543	32	1.260	70	2.756	6	0.236	28	1.102	90	23	0.906	

Frame Size	L1		L2		M		N		O		P		Q		R		S
	mm	in	mm	in	mm	in	mm	in	mm	in	mm	in	mm	in	mm	in	
PV40TN	48.5	1.909	63	2.480	3.1	0.122	16	0.630	10.2	0.402	3	0.118	0.6	0.024	11.633	0.458	M3x6
PV40TA	48.5	1.909	63	2.480	1.3	0.051	16	0.630	13.5	0.531	4	0.157	3.5	0.138	17.831	0.702	M4x8
PV60TN	63	2.480	83	3.268	2.71	0.107	25	0.984	16	0.630	5	0.197	2.5	0.098	19.939	0.785	M5x12
PV60TA	67	2.638	87	3.425	2.21	0.087	25	0.984	18	0.709	5	0.197	3	0.118	28	1.102	M5x12
PV90TN	82	3.228	105.5	4.154	4.197	0.165	28	1.102	22.5	0.886	6	0.236	1	0.039	25	0.984	M6x12
PV90TA	85.5	3.366	109	4.291	3.197	0.126	28	1.102	24.5	0.965	6	0.236	5	0.197	38	1.496	M8x13
PV115TN	102	4.016	136	5.354	5.2	0.205	40	1.575	28	1.102	8	0.315	1	0.039	35	1.378	M10x20
PV115TA	110	4.331	144	5.669	4	0.157	50	1.969	35	1.378	10	0.394	1.8	0.071	40	1.575	M12x22





## Dimensions – Flange Face (FB, FE & FN)

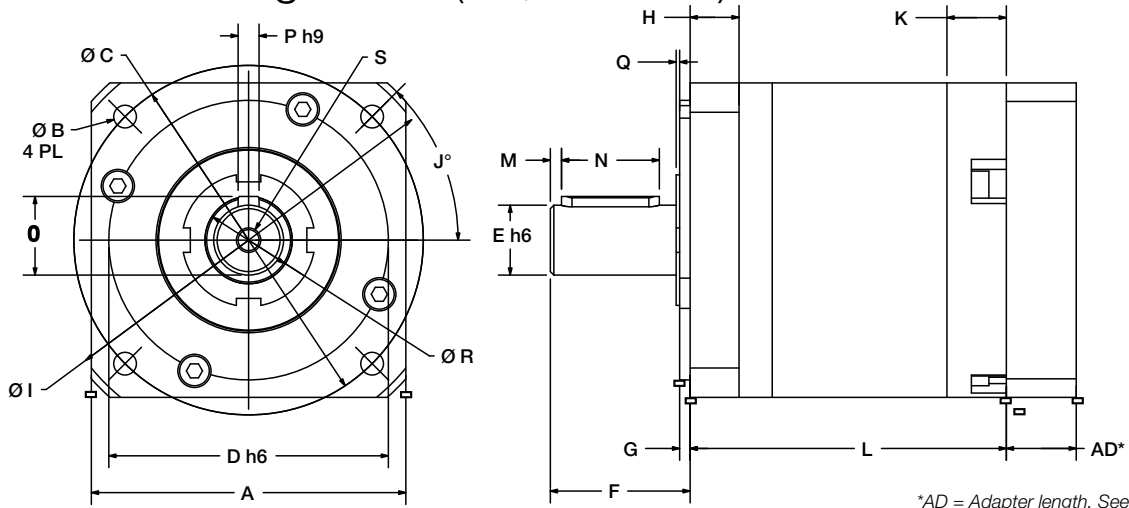

\*AD = Adapter length. See how to order page for mounting kit adapter lengths.

### Metric & NEMA Frame Sizes

Frame Size	A		B		C		D		E		F		G		H		I		J	
	mm	in	mm	in	mm	in	mm	in	mm	in	mm	in	mm	in	mm	in	mm	in	°	
Metric	PV40FB	43	1.693	3.4	0.134	50	1.969	35	1.378	13	0.512	26	1.024	3	0.118	10	0.394	56	2.205	45
	PV60FB	62	2.441	5.5	0.217	70	2.756	50	1.969	16	0.630	25	0.984	2.5	0.098	10.3	0.406	80	3.150	45
	PV60FN	62	2.441	5.5	0.217	70	2.756	50	1.969	14	0.551	25	0.984	2.5	0.098	10.3	0.406	80	3.150	45
	PV90FB	90	3.543	6.5	0.256	100	3.937	80	3.150	20	0.787	40	1.575	3	0.118	14	0.551	116	4.567	45
	PV90FN	90	3.543	6.5	0.256	100	3.937	80	3.150	20	0.787	40	1.575	3	0.118	14	0.551	116	4.567	45
	PV115FB	115	4.528	8.5	0.335	130	5.118	110	4.331	24	0.945	50	1.969	3.5	0.138	18	0.709	152	5.984	45
	PV115FN	115	4.528	8.5	0.335	130	5.118	110	4.331	25	0.984	55	2.165	3.5	0.138	18	0.709	152	5.984	45
NEMA	PV17FE	43	1.693	3.5	0.138	43.8	1.724	22	0.866	6.35	0.250	25.4	0.984	1.5	0.059	6	0.236	55	2.165	45
	PV23FE	62	2.441	4.95	0.195	66.75	2.625	38.1	1.500	9.525	0.375	25.4	1.000	2.5	0.098	9.5	0.374	80	3.150	45
	PV34FE	90	3.543	5.52	0.217	98.43	3.875	73.025	2.875	12.7	0.500	31.75	1.250	3	0.118	15	0.591	116	4.567	45
	PV42FE	115	4.528	7.14	0.281	125.7	4.949	55.55	2.187	15.875	0.625	38.1	1.500	2.4	0.094	20	0.787	152	5.984	45
Frame Size	K		L1		L2		M		N		O		P		Q		R		S	
	mm	in	mm	in	mm	in	mm	in	mm	in	mm	in	mm	in	mm	in	mm	in		
Metric	PV40FB	11	0.433	48.5	1.909	63	2.480	2.1	0.083	16	0.630	15	0.591	5	0.197	2	0.079	17.831	0.702	M4x8
	PV60FB	16	0.630	71.5	2.815	91.5	3.602	3.2	0.126	16	0.630	18	0.709	5	0.197	1	0.039	28	1.102	M5x12
	PV60FN	16	0.630	71.5	2.815	91.5	3.602	3.2	0.126	16	0.630	16	0.630	5	0.197	1	0.039	28	1.102	M5x12
	PV90FB	17	0.670	90.5	3.563	114	4.488	3.197	0.126	28	1.102	22.5	0.886	6	0.236	1	0.039	38	1.496	M6x12
	PV115FB	23	0.906	114.5	4.508	148.5	5.846	4.2	0.165	40	1.575	27	1.063	8	0.315	1.5	0.059	40	1.575	M10x22
	PV115FN	23	0.906	114.5	4.508	148.5	5.846	4.2	0.165	40	1.575	27	1.063	8	0.315	1.5	0.059	40	1.575	M10x22
NEMA	PV17FE	11	0.433	48.5	1.909	63	2.480	-	-	-	-	-	-	-	-	0.091	2.3	0.458	11.633	-
	PV23FE	16	0.630	60.5	2.382	80.5	3.169	-	-	0.748	19	0.372	9.444	Flat	0.039	1	0.785	19.939	M5x12	
	PV34FE	17	0.670	82	3.228	105.5	4.154	-	-	1.063	27	0.561	14.247	0.125	3.175	0.039	1	0.984	25	M6x12
	PV42FE	23	0.906	102	4.016	136	5.354	0.016	0.4	1.120	28.45	0.705	17.91	0.188	4.775	-	-	-	-	M6x20

## How to Order

Use the tables below to configure your PV gearhead and motor mounting part number.

### Gearhead Ordering Information

Order Example:		①	②	③	④	⑤
		PV	40	T	N	- 004

①	②	③	④	⑤
Series	Frame Size	Front Face	Output Face Compatible	Ratio
PV Power Versatility Series	40 40 mm	T Tapped (round)	A Alpha/Stober N Neugart	004 4:1 005 5:1
		F Flanged (square)	B Parker Bayside (PX)	007 7:1 010 10:1 016 16:1 020 20:1 025 25:1
		F Flanged (square)	E NEMA (English)	035 35:1 040 40:1 050 50:1 070 70:1 100 100:1
	17 NEMA 17	F Flanged (square)	E NEMA (English)	035 35:1 040 40:1 050 50:1 070 70:1 100 100:1
		F Flanged (square)	E NEMA (English)	035 35:1 040 40:1 050 50:1 070 70:1 100 100:1
	60 60 mm	T Tapped (round)	A Alpha/Stober N Neugart	003 3:1 004 4:1
		F Flanged (square)	B Parker Bayside (PX) N Neugart	005 5:1 007 7:1
	23 NEMA 23	F Flanged (square)	E NEMA (English)	010 10:1 012 12:1
	90 90 mm	T Tapped (round)	A Alpha/Stober N Neugart	015 15:1 020 20:1
		F Flanged (square)	B Parker Bayside (PX)	025 25:1
	34 NEMA 34	F Flanged (square)	E NEMA (English)	030 30:1 040 40:1
	115 115 mm	T Tapped (round)	A Alpha/Stober N Neugart	050 50:1 070 70:1
		F Flanged (square)	B Parker Bayside (PX)	100 100:1
	42 NEMA 42	F Flanged (square)	E NEMA (English)	100 100:1

### Mounting Kit Ordering Information

Order Example:		⑥	⑦	⑧
		MV	60	XXX

⑥	⑦	⑧
Series	Frame Size	Factory Assigned
MV (Mounting kit for PV)	40 40 or 17 60 60 or 23 90 90 or 34 115 115 or 42	See Motor Mounting Search Tool on <a href="http://parkermotion.com">parkermotion.com</a> or consult factory for part number XXX

### Mounting Kit Adapter Length\*

Frame Size	Motor Shaft Length		"AD"	
	mm	(in)	mm	(in)
40/17	12 thru 20	(0.472 thru 0.787)	13.7	(0.539)
	20.1 thru 25.4	(0.791 thru 1.000)	19.0	(0.748)
60/23	16 thru 25.4	(0.630 thru 1.000)	16.5	(0.650)
	25.4 thru 31.8	(1.004 thru 1.252)	22.5	(0.886)
90/34	20 thru 31.8	(0.787 thru 1.252)	20.0	(0.787)
	31.9 thru 40	(1.256 thru 1.575)	28.5	(1.122)
115/42	22 thru 40	(0.866 thru 1.575)	24.0	(0.945)
	40.1 thru 51	(1.579 thru 2.008)	35.0	(1.378)

\* Adapter length may vary depending on motor make and model.





## Parker Gearhead Product Overview

Product Series	Precision/Gear Geometry	In-Line/ Right Angle	Frame Sizes mm (NEMA)	Torque Continuous Nm (in-lbs)	Ratios	Backlash arc-min (std/low)	IP Rating
<b>PS</b> 	High Precision / Helical Planetary	In-Line	60 to 220	40 to 1800 (355 to 16,000)	3 to 100	4-8 (std) 3-6 (low)	IP65
<b>RS</b> 	High Precision / Helical Planetary / Spiral Bevel	Right Angle	60 to 220	35 to 1800 (310 to 16,000)	5 to 100	8-14 (std) 4-10 (low)	IP65
<b>PX</b> 	Mid Precision / Helical Planetary	In-Line	60 to 142 (NEMA 23 to NEMA 56)	30 to 280 (265 to 2500)	3 to 100	8-12 (std) 6-10 (low)	IP65
<b>RX</b> 	Mid Precision / Helical Planetary / Spur Bevel	Right Angle	60 to 142 (NEMA 23 to NEMA 56)	25 to 130 (220 to 1150)	5 to 100	16-20 (std) 12-18 (low)	IP65
<b>PV</b> 	Lower Precision / Planetary	In-Line	40 to 90 (NEMA 17 to NEMA 34)	6.5 to 71 (57 to 630)	3 to 100	10-18 (std)	IP64
<b>RT RD RB</b> 	High Precision / Spiral Bevel / Helical	Right Angle	90 to 220	23 to 565 (200 to 5000)	RT: 3 to 30 RD: 1 to 30 RB: 1 to 3	8-12 (std) 4-8 (low)	IP65
<b>NE/ NR</b> 	Lower Precision / Spur	In-Line & Right Angle	NEMA 23 to NEMA 42	6 to 40 (50 to 350)	NE: 3 to 100 NR: 1 to 100	20-30 (std) 10-15 (low)	IP54

# EM Sales Offices

## Australia

### Parker Hannifin (Australia) Pty Limited

9 Carrington Road  
Castle Hill NSW 2154  
Australia  
Tel: +61 (0) 2 9634-7777  
Fax: +61 (0) 2 9634 3749

## Brazil

### Parker Hannifin Ind. Com Ltda.

Av. Lucas Nogueira Garcez 2181  
Esperança  
12325-900 Jacareí, SP  
Tel: 12 3954 5100  
Fax: 12 3954 5262  
Email: automation.brazil@parker.com

## Canada

### Parker Hannifin (Canada) Inc.

160 Chisholm Dr  
Milton, Ontario L9T 3G9  
Tel: 905-693-3000  
Fax: 905-876-1958  
Email: miltoncustservice@parker.com

## China

### Parker Hannifin Motion & Control (Shanghai) Co., Ltd

280 Yunqiao Rd. Jin Qiao Export Processing Zone  
Shanghai 201206, China  
Tel: (86-21) 50312525  
Fax: (86-21) 64459717

## France

### Parker SSD Parvex

8 avenue du Lac  
B.P. 249  
F-21007 Dijon Cedex  
Tel: +33 (0) 3 80 42 41 40  
Fax: +33 (0) 3 80 42 41 23

## Germany

### Electromechanical Europe Parker Hannifin GmbH & Co KG

Robert-Bosch-Strasse 22  
D-77656 Offenburg  
Germany  
Tel: +49 (0) 781 509 0  
Fax: +49 (0) 781 509 98176

## India

### Parker Hannifin India Pvt. Ltd Automation Group-SSD Drives Division

133 & 151 Developed Plots Estate  
Perungudi, Chennai 600 096  
Tel: 044-4391-0799  
Fax: 044-4391-0700

## Italy

### Parker Hannifin SpA

Via Gounod 1  
20092 Cinsello Balsamo  
Milano, Italy  
Tel: +39 02 361081  
Fax: +39 02 36108400

## Korea

### Parker Hannifin Korea

9th Floor KAMCO Yangjae Tower  
949-3 Dogok 1-dong Gangnam-gu  
Seoul 135-860, Korea  
Tel: 82-2-559-0454  
Fax: 82-2-556-8187

## Mexico

### Parker Hannifin de Mexico

Eje uno Norte No.100  
Parque Industrial Toluca 2000  
Toluca, CP 50100 México  
Tel: 52-722-275-4200  
Fax: 52-722-279-0316

## Singapore

### Parker Hannifin Singapore Pte Ltd

11, Fourth Chin Bee Road  
Singapore 619702  
Tel: (65) 6887 6300  
Fax: (65) 6265 5125/6261 4929

## Taiwan

### Parker Hannifin Taiwan Co., Ltd

No. 40, Wuchiuan 3rd Road  
Wuku Industrial Park  
Taipei County, Taiwan 248  
ROC  
Tel: 886 2 2298 8987  
Fax: 886 2 2298 8982

## Thailand

### Parker Hannifin (Thailand) Co., Ltd.

1023, 3rd Floor, TPS Building,  
Pattanakarn Road,  
Suanluang, Bangkok 10250  
Thailand  
Tel: (66) 02717 8140  
Fax: (66) 02717 8148

## UK

### Parker Hannifin Ltd.

Tachbrook Park Drive  
Tachbrook Park  
Warwick CV34 6TU  
Tel: +44 (0) 1926 317970  
Fax: +44 (0) 1926 317980

## USA

### Parker Hannifin Electromechanical Automation Division Main Office/ Compumotor/CTC

5500 Business Park Drive  
Rohnert Park, CA 94928 USA  
Tel: 707-584-7558  
800-358-9070  
Fax: 707-584-8015  
Email: emn\_support@parker.com

### Parker Hannifin Electromechanical Automation Division/Bayside

27 Seaview Boulevard  
Port Washington, NY 11050  
Tel: 707-584-7558  
800-358-9070  
Fax: 707-584-8015  
Email: emn\_support@parker.com

### Parker Hannifin Electromechanical Automation Division/Daedal

1140 Sandy Hill Road  
Irwin, PA 15642  
Tel: 724-861-8200  
800-245-6903  
Fax: 724-861-3330  
Email: ddc@parker.com

Catalog 8009  
5/09 Printed in U.S.A.



## Parker Hannifin Corporation Electromechanical Automation Div.

Parker Bayside  
27 Seaview Boulevard  
Port Washington, NY 11050  
Phone: 800-305-4555  
Fax: 516-629-8000  
www.parkermotion.com