

Servomotors

NX Series

Technical Manual

PVD 3663

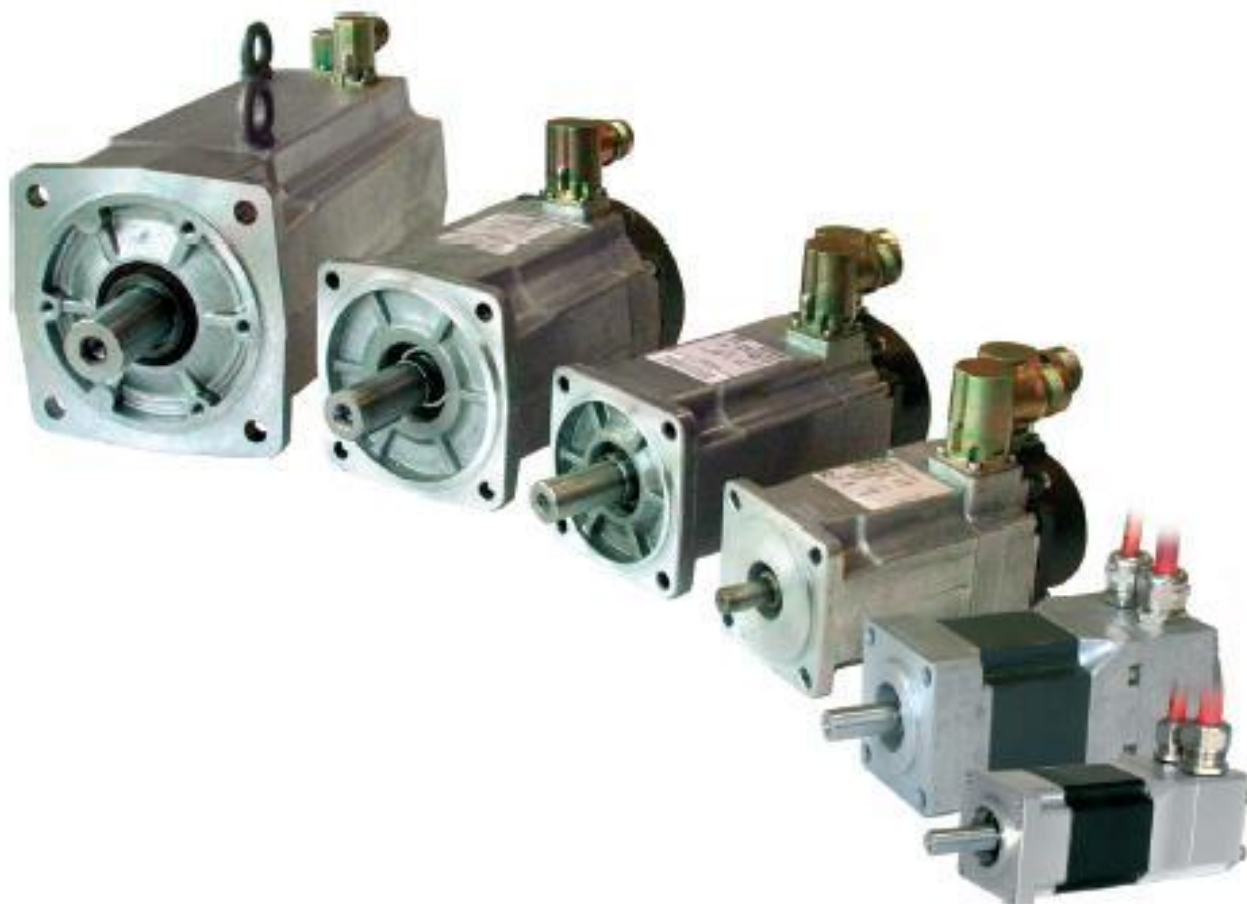



DECLARATION CE OF CONFORMITY

We ,

Parker Hannifin Manufacturing France SAS
Etablissement de Dijon
8 Avenue du Lac CS 30749
21007 DIJON CEDEX

certify that the product

SERVOMOTORS TYPE NX1

satisfy the arrangements of the directives :

EC directive 2006/95 “Electrical equipment designed for use within certain voltage limit”

EC directive 2011/65 “Restriction of hazardous substances”

and meet standards or normative document according to :

IEC 60034-1 Ed 12 02-2010 : “rotating electrical machinery”: part 1 : Rating and performance.

IEC 60034-5 Ed 4.1 11-2006 : “rotating electrical machinery”: part 5 : Degrees of protection provided by the integral design of rotating electrical machine.

Further information :

SERVOMOTORS shall be mounted on a mechanical support providing good heat conduction and not exceeding 40° C in the vicinity of the motor flange.

The instructions and recommendations of the user manual supplied with the product, together with the servo amplifier commissioning manual instructions must be applied.

C.E. Marking in : October 2004

DIJON, January 27th 2014

QUALITY MANAGER
S. POIZOT



DECLARATION CE OF CONFORMITY

We ,

Parker Hannifin Manufacturing France SAS
Etablissement de Dijon
8 Avenue du Lac CS 30749
21007 DIJON CEDEX

certify that the product

SERVOMOTORS TYPE NX2

satisfy the arrangements of the directives :

EC directive 2006/95 “Electrical equipment designed for use within certain voltage limit”

EC directive 2011/65 “Restriction of hazardous substances”

and meet standards or normative document according to :

IEC 60034-1 Ed 12 02-2010 : “rotating electrical machinery”: part 1 : Rating and performance.

IEC 60034-5 Ed 4.1 11-2006 : “rotating electrical machinery”: part 5 : Degrees of protection provided by the integral design of rotating electrical machine.

Further information :

SERVOMOTORS shall be mounted on a mechanical support providing good heat conduction and not exceeding 40° C in the vicinity of the motor flange.

The instructions and recommendations of the user manual supplied with the product, together with the servo amplifier commissioning manual instructions must be applied.

C.E. Marking in : November 2004

DIJON, January 27th 2014

QUALITY MANAGER
S. POIZOT



DECLARATION CE OF CONFORMITY

We ,

Parker Hannifin Manufacturing France SAS
Etablissement de Dijon
8 Avenue du Lac CS 30749
21007 DIJON CEDEX

certify that the product

SERVOMOTORS TYPE NX3

satisfy the arrangements of the directives :

EC directive 2006/95 “Electrical equipment designed for use within certain voltage limit”

EC directive 2011/65 “Restriction of hazardous substances”

and meet standards or normative document according to :

IEC 60034-1 Ed 12 02-2010 : “rotating electrical machinery”: part 1 : Rating and performance.

IEC 60034-5 Ed 4.1 11-2006 : “rotating electrical machinery”: part 5 : Degrees of protection provided by the integral design of rotating electrical machine.

Further information :

SERVOMOTORS shall be mounted on a mechanical support providing good heat conduction and not exceeding 40° C in the vicinity of the motor flange.

The instructions and recommendations of the user manual supplied with the product, together with the servo amplifier commissioning manual instructions must be applied.

C.E. Marking in : September 27th 2001

DIJON, January 27th 2014

QUALITY MANAGER
S. POIZOT



DECLARATION CE OF CONFORMITY

We ,

Parker Hannifin Manufacturing France SAS
Etablissement de Dijon
8 Avenue du Lac CS 30749
21007 DIJON CEDEX

certify that the product

SERVOMOTORS TYPE NX4

satisfy the arrangements of the directives :

EC directive 2006/95 “Electrical equipment designed for use within certain voltage limit”

EC directive 2011/65 “Restriction of hazardous substances”

and meet standards or normative document according to :

IEC 60034-1 Ed 12 02-2010 : “rotating electrical machinery”: part 1 : Rating and performance.

IEC 60034-5 Ed 4.1 11-2006 : “rotating electrical machinery”: part 5 : Degrees of protection provided by the integral design of rotating electrical machine.

Further information :

SERVOMOTORS shall be mounted on a mechanical support providing good heat conduction and not exceeding 40° C in the vicinity of the motor flange.

The instructions and recommendations of the user manual supplied with the product, together with the servo amplifier commissioning manual instructions must be applied.

C.E. Marking in : march 15th 2000

DIJON, January 27th 2014

QUALITY MANAGER
S. POIZOT



DECLARATION CE OF CONFORMITY

We ,

Parker Hannifin Manufacturing France SAS
Etablissement de Dijon
8 Avenue du Lac CS 30749
21007 DIJON CEDEX

certify that the product

SERVOMOTORS TYPE NX6

satisfy the arrangements of the directives :

EC directive 2006/95 “Electrical equipment designed for use within certain voltage limit”

EC directive 2011/65 “Restriction of hazardous substances”

and meet standards or normative document according to :

IEC 60034-1 Ed 12 02-2010 : “rotating electrical machinery”: part 1 : Rating and performance.

IEC 60034-5 Ed 4.1 11-2006 : “rotating electrical machinery”: part 5 : Degrees of protection provided by the integral design of rotating electrical machine.

Further information :

SERVOMOTORS shall be mounted on a mechanical support providing good heat conduction and not exceeding 40° C in the vicinity of the motor flange.

The instructions and recommendations of the user manual supplied with the product, together with the servo amplifier commissioning manual instructions must be applied.

C.E. Marking in : march 27th 2000

DIJON, January 27th 2014

QUALITY MANAGER
S. POIZOT



DECLARATION CE OF CONFORMITY

We ,

Parker Hannifin Manufacturing France SAS
Etablissement de Dijon
8 Avenue du Lac CS 30749
21007 DIJON CEDEX

certify that the product

SERVOMOTORS TYPE NX8

satisfy the arrangements of the directives :

EC directive 2006/95 “Electrical equipment designed for use within certain voltage limit”

EC directive 2011/65 “Restriction of hazardous substances”

and meet standards or normative document according to :

IEC 60034-1 Ed 12 02-2010 : “rotating electrical machinery”: part 1 : Rating and performance.

IEC 60034-5 Ed 4.1 11-2006 : “rotating electrical machinery”: part 5 : Degrees of protection provided by the integral design of rotating electrical machine.

Further information :

SERVOMOTORS shall be mounted on a mechanical support providing good heat conduction and not exceeding 40° C in the vicinity of the motor flange.

The instructions and recommendations of the user manual supplied with the product, together with the servo amplifier commissioning manual instructions must be applied.

C.E. Marking in : December 23th 2003

DIJON, January 27th 2014

QUALITY MANAGER
S. POIZOT



Compliance with «UL» standards

A part of the NX servomotors Series complies with the UL standards UL1004-1.
The UL standards compliance is only possible:

For NX1 and NX2:

In class A according to IEC 60034-1

AND

with connector (option code 7)

AND

with correct torque / speed choice (see performances tab)

nota: high speed version avoid UL certification.

For NX3, NX4 and NX6

with connector (option code 7)

AND

with correct torque / speed choice (see performances tab)

nota: high speed version avoid UL certification.

For NX8

with connector (option code 7) or fan cooled with thermal box (option code 5)

AND

with correct torque / speed choice (see performances tab)

nota: high speed version avoid UL certification.

Compliance with these standards requires servomotors to be mounted in accordance with the recommendations given in this commissioning and user manual.

Equipment shall furthermore be mounted on a mechanical support that conducts heat effectively and does not exceed 40°C in the vicinity of the motor flange.

PARKER HANNIFIN MANUFACTURING FRANCE SAS

8, avenue du Lac – BP30749

F-21007 DIJON CEDEX

Tel : +33 (0)3 80 42 41 40

Fax : +33 (0)3 80 42 41 23

www.parker.com



Table of Content

1. INTRODUCTION	11
1.1. Purpose and intended audience	11
1.2. Safety	11
1.2.1. Principle	11
1.2.2. General Safety Rules	12
2. PRODUCT DESCRIPTION	13
2.1. Quick URL	13
2.2. Overview	13
2.3. Applications	13
2.4. General Technical Data	14
2.5. Product Code	15
3. TECHNICAL DATA	16
3.1. Motor selection	16
3.1.1. Altitude derating	16
3.1.2. Temperature derating	16
3.1.3. Thermal equivalent torque (rms torque)	18
3.1.4. Drive selection	20
3.1.5. Current limitation at stall conditions (i.e. speed < 3 rpm)	23
3.1.6. Peak current limitations	23
3.2. NX Characteristics: Torque, speed, current, power	24
3.2.1. Efficiency curves	27
3.2.2. Electromagnetic losses	35
3.2.3. Time constants of the motor	36
3.2.4. Speed ripple	38
3.2.5. Rated data according to rated voltage variation	39
3.2.6. Voltage withstand characteristics of NX series	41
3.3. Dimension drawings	42
3.3.1. NX1	42
3.3.2. NX1 UL version	45
3.3.3. NX2	49
3.3.4. NX2 UL version	53
3.3.5. NX3	57
3.3.6. NX4	60
3.3.7. NX6	64
3.3.8. NX8	67
3.3.9. NX8 water cooled	71
3.4. Motor Mounting	72
3.4.1. Motor mounting	72
3.4.2. Frame recommendation	73
3.5. Shaft Loads	74
3.5.1. Vibration resistance to shaft end	74
3.5.2. Motors life time for horizontal mounting	74
3.6. Cooling	80
3.6.1. Natural and fan cooled motor	80
3.6.2. Water cooled motor	80
3.6.3. Additives for water as cooling media	81
3.6.4. Motor cooling circuit drop pressure	82
3.6.5. Chiller selection	82
3.6.6. Flow derating according to glycol concentration	83
3.6.7. Water cooling diagram	85
3.7. Thermal Protection	87
3.7.1. Alarm tripping with PTC thermistors	87
3.7.2. Temperature measurement with KTY sensors	88
3.8. Power Electrical Connections	89
3.8.1. Wires sizes	89
3.8.2. Conversion Awg/kcmil/mm ²	90
3.8.3. Motor cable length	91

3.8.4.	Mains supply connection diagrams	92
3.9.	Feedback system	99
3.9.1.	Resolver 2 poles transformation ratio = 0.5 – code A	99
3.9.2.	Hiperface encoder singleturn SKS36 (128pulses) – code R.....	99
3.9.3.	Hiperface encoder multiturn SKM36 (128pulses) – code S	100
3.9.4.	Hiperface encoder singleturn SRS50 (1024pulses) – code T	100
3.9.5.	Hiperface encoder multiturn SRM50 (1024pulses) – code U.....	101
3.9.6.	Endat encoder singleturn ECN1113 – code V	101
3.9.7.	Endat encoder multiturn ECN1125 – code W	102
3.9.8.	Incremental encoder - Commuted lines 10 poles – 2048pulses – code X (On request)	104
3.9.9.	Cables.....	105
3.10.	Brake option	107
4.	COMMISSIONING, USE AND MAINTENANCE	108
4.1.	Instructions for commissioning, use and maintenance	108
4.1.1.	Equipment delivery	108
4.1.2.	Handling	108
4.1.3.	Storage	109
4.2.	Installation	109
4.2.1.	Mounting	109
4.2.2.	Preparation	110
4.2.3.	Mechanical installation	110
4.3.	Electrical connections	111
4.3.1.	Cable connection.....	112
4.3.2.	Encoder cable handling.....	112
4.4.	Maintenance Operations	113
4.4.1.	Summary maintenance operations.....	113
4.5.	Troubleshooting	114

1. INTRODUCTION

1.1. Purpose and intended audience

This manual contains information that must be observed to select, install, operate and maintain PARKER NX servomotors.

Installation, operation and maintenance of the equipment should be carried out by qualified personnel. A qualified person is someone who is technically competent and familiar with all safety information and established safety practices; with the installation process, operation and maintenance of this equipment; and with all the hazards involved.

Reading and understanding the information described in this document is mandatory before carrying out any operation on the motors. If any malfunction or technical problem occurs, that has not been dealt with in this manual, please contact PARKER for technical assistance. In case of missing information or doubts regarding the installation procedures, safety instructions or any other issue tackled in this manual, please contact PARKER as well.

PARKER's responsibility is limited to its servomotors and does not encompass the whole user's system. Data provided in this manual are for product description only and may not be guaranteed, unless expressly mentioned in a contract.



DANGER: PARKER declines responsibility for any industrial accident or material damage that may arise, if the procedures and safety instructions described in this manual are not scrupulously followed.

1.2. Safety





1.2.1. Principle

To operate safely, this equipment must be transported, stored, handled, installed and serviced correctly. Following the safety instructions described in each section of this document is mandatory. Servomotors usage must also comply with all applicable standards, national directives and factory instructions in force.



DANGER: Non-compliance with safety instructions, legal and technical regulations in force may lead to physical injuries or death, as well as damages to the property and the environment.

1.2.2. General Safety Rules

	<p>Generality <u>DANGER:</u> The installation, commission and operation must be performed by qualified personnel, in conjunction with this documentation.</p> <p>The qualified personnel must know the safety (C18510 authorization, standard VDE 0105 or IEC 0364) and local regulations.</p> <p>They must be authorized to install, commission and operate in accordance with established practices and standards.</p>
	<p>Electrical hazard</p> <p>Servo drives may contain non-insulated live AC or DC components. Respect the drives commissioning manual. Users are advised to guard against access to live parts before installing the equipment.</p> <p>Some parts of the motor or installation elements can be subjected to dangerous voltages, when the motor is driven by the inverter , when the motor rotor is manually rotated, when the motor is driven by its load, when the motor is at standstill or stopped.</p> <p>For measurements use only a meter to IEC 61010 (CAT III or higher). Always begin using the highest range. CAT I and CAT II meters must not be used on this product.</p> <p>Allow at least 5 minutes for the drive's capacitors to discharge to safe voltage levels (<50V). Use the specified meter capable of measuring up to 1000V dc & ac rms to confirm that less than 50V is present between all power terminals and between power terminals and earth.</p> <p>Check the drive recommendations. The motor must be permanently connected to an appropriate safety earth. To prevent any accidental contact with live components, it is necessary to check that cables are not damaged, stripped or not in contact with a rotating part of the machine. The work place must be clean, dry.</p> <p>General recommendations :</p> <ul style="list-style-type: none"> - Check the wiring circuit - Lock the electrical cabinets - Use standardized equipment
	<p>Mechanical hazard</p> <p>Servomotors can accelerate in milliseconds. Running the motor can lead to other sections of the machine moving dangerously. Moving parts must be screened off to prevent operators coming into contact with them. The working procedure must allow the operator to keep well clear of the danger area.</p>
	<p>Burning Hazard</p> <p>Always bear in mind that some parts of the surface of the motor can reach temperatures exceeding 100°C.</p>



2. PRODUCT DESCRIPTION

2.1. Quick URL

All informations and datas are available on :

<http://www.parker.com/eme/nx>

2.2. Overview

NX servomotors Series from PARKER is an innovative direct drive solution designed for industrial applications. NX Series brushless servomotors from Parker SSD Parvex combine exceptional precision and motion quality, high dynamic performances and very compact dimensions.

A large set of torque / speed characteristics, options and customization possibilities are available, making NX Series servomotors the ideal solution for most servosystems applications.

Advantages

- High precision
- High motion quality
- High dynamic performances
- Compact dimensions and robustness
- Large set of options and customization possibilities
- CE and UL marking certification available.

2.3. Applications

Medical: Blood pumps, air pump, radiology tables,...

Machine tools: Ancillary axis, spindle, axis...

Semiconductor

Hand tool: screwdriver,...

Packaging machinery

Robot applications

Special machines

Pumps

2.4. General Technical Data

	NX1	NX2	NX3, NX4, NX6	NX8
Motor type	Permanent-magnet synchronous motor			
Magnets material	Neodymium Iron Boron			
Number of poles	10			
Type of construction	IMB5 – IMV1 – IMV3 (EN60034-7)			
Degree of protection	<ul style="list-style-type: none"> • IP64, • IP65 in option 		<ul style="list-style-type: none"> • IP64, • IP65 in option • IP44 in fan cooled version 	
Cooling	<ul style="list-style-type: none"> • Natural cooling 		<ul style="list-style-type: none"> • Natural cooling, • Fan cooled • Water cooled 	
Rated voltage	230VAC	230VAC, 400 VAC and 480 VAC		
Insulation of the stator winding	Class F according to IEC 60034-1 with potting		Class F according to IEC 60034-1	Class F according to IEC 60034-1 with potting
Altitude	Up to 1000m (IEC 60034-1) (for higher altitude see §3.1.1 for derating)			
Ambiant temperature	<ul style="list-style-type: none"> • -15°C to +40°C (IEC 60034-1) • -40°C on request • 0°C to 40°C for water cooled version (IEC 60034-1) to avoid condensation see §3.6 			
Storage temperature	-20... +60°C			
Vibration severity	Grade A according to IEC 60034-14			
Shaft	Plain shaft as standard – key on shaft in option			
Connection	<ul style="list-style-type: none"> • Connector, • Cable (Not UL) • Flying wires (Not UL) 		<ul style="list-style-type: none"> • Connectors • Terminal box 	
Marking	<ul style="list-style-type: none"> • CE, • UL in class A in option 		<ul style="list-style-type: none"> • CE, • UL in option 	
Paint finish	Raw in standard, Black RAL 9005 in option			
Sensor	Resolver transformation ratio = 0.5 as standard			
Hiperface - SKS36	N/A	Option	Option	
Hiperface - SKM36	N/A	Option	Option	
Hiperface – SRS50	N/A	N/A	Option	
Hiperface – SRM50	N/A	N/A	Option	
Endat ECN1113	N/A	N/A	Option	
Endat ECN1125	N/A	N/A	Option	
Incremental 2048line	N/A	On request	On request	
Sensorless	N/A	Option	Option	
Brake	Parking brake in option			
Thermal protection	PTC, Thermoswitch or KTY as an option			
Remark	Numerous customization are possible on request (special shaft, connection, encoder, ...)			

2.5. Product Code

Code	N	X	3	1	0	E	A	K	R	1	0	0	0	
Product Series														
Motor size 1, 2, 3, 4, 6 or 8 in relation with the motor diameter														
Motor length up to 60 depend on size														
Windings variant A: serial windings class A (only for NX1 & 2 in UL version) E: standard serial windings class F V: serial windings class F fan cooled W: serial windings class F water cooled														
Feedback Sensor A: resolver 2 poles transformation ratio = 0.5 K: without sensor R: Hiperface encoder singleturn SKS36 (128pulses) S: Hiperface encoder mutiturn SKM36 (128pulses) T: Hiperface encoder singleturn SRS50 (1024pulses) U: Hiperface encoder mutiturn SRM50 (1024pulses) V: Endat encoder singleturn ECN1113 W: Endat encoder multiturn ECN1125 X: Commuted lines 10 poles – 2048pulses, on request Y: sensorless series for 650S drive Z : Special encoder														
Torque / Speed Characteristics See motor data														
Painting R: no painting B: Black RAL9005														
Electric connection 1: 1m cable shielded for NX3, 4, 6 & 8 (Not UL) 1m cable not shielded for NX1 & 2 (Not UL) 4: 1m flying wires inside PVC sheath-only for NX1 & 2 (Not UL) 5: terminal box – motor with fan cooling in UL version 6: terminal box (Not UL) 7: connector 8: connector – motor with fan cooling (Not UL) 9: terminal box – motor with fan cooling (Not UL)														
Break and thermal sensor option Sensor on power connector 0: No break, no thermal sensor 1: PTC sensor 2: Thermo switch 3: with brake 4: with brake and PTC sensor 5: with brake and thermo switch 6: KTY84-130 sensor 7: with brake and KTY sensor Sensor on signal connector A: PTC sensor B: Thermo switch C: KTY sensor D: with brake and PTC sensor E: with brake and thermo switch F: with brake and KTY sensor														
Mechanical Interface 00: plain shaft 01: key on shaft Other: custom code 10: IP65 with plain shaft 11: IP65 with key on shaft														

Note: All associations are not possible – Contact Parker for checking.

3. TECHNICAL DATA

3.1. Motor selection

3.1.1. Altitude derating

From 0 to 1000 m : no derating

1000 to 4000 m: torque derating of 5% for each step of 1000 m for water cooled

1000 to 4000 m: torque derating of 10% for each step of 1000 m for air cooled

3.1.2. Temperature derating

3.1.2.1. Natural cooled motor

The maximal temperature for natural cooling is 40°C. But, it is possible to increase a little bit the ambient temperature above 40°C, with a torque reduction. The following formula gives an indicative about the torque derating at low speed. But in any case refer to PARKER technical department to know the exact values

At low speed the torque derating is given by the following formula for an ambient temperature > 40°C.

$$\text{Torque_derating}[\%] = 100 * \sqrt{\frac{(145^{\circ}\text{C} - \text{Ambient_temperature}^{\circ}\text{C})}{105^{\circ}\text{C}}}$$

	<p>At high speed, the calculation is more complex, and the derating is much more important. Please refer to PARKER to know the precise data of Torque derating according to ambient temperature at high speed for a specific motor.</p>
---	---

Illustration: Only for example given for the NX620EAR :



3.1.2.2. Water cooled motor

Typical values are given with a water inlet temperature of 25°C and a temperature gradient Inlet-Outlet of 10°C. These references lead to a winding overheating of 95°C corresponding to a winding temperature of 120°C. Recommendations regarding condensation issues are given at § 3.5

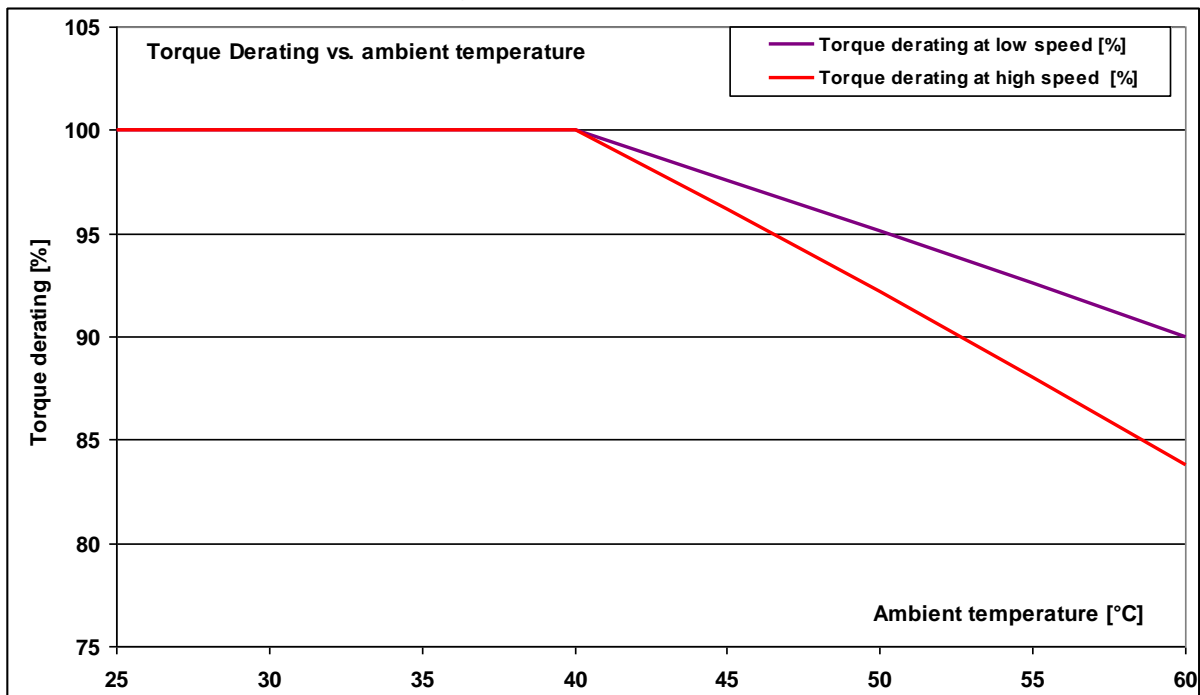
It is possible to increase a little bit the Inlet temperature up to 40°C, but the torque must be reduced. The following formula gives an indicative of the torque derating at low speed. But in any case refer to PARKER technical department to know the exact values

At low speed the torque derating is given by the following formula for an water Inlet temperature > 25°C.

$$Torque_derating[\%] = 100 * \sqrt{\frac{(120^{\circ}C - Inlet_temperature^{\circ}C)}{95^{\circ}C}}$$

	<p>At high speed, the calculation is more complex, and the derating is much more important. Please refer to PARKER to know the precise data of Torque derating according to water inlet temperature at high speed for a specific motor.</p>
---	---

Illustration: Only for example given for the NX860WAF



3.1.3. Thermal equivalent torque (rms torque)

The selection of the right motor can be made through the calculation of the rms torque M_{rms} (i.e. root mean squared torque) (sometimes called equivalent torque). This calculation does not take into account the thermal time constant. It can be used only if the overload time is much shorter than the copper thermal time constant. The rms torque M_{rms} reflects the heating of the motor during its duty cycle.

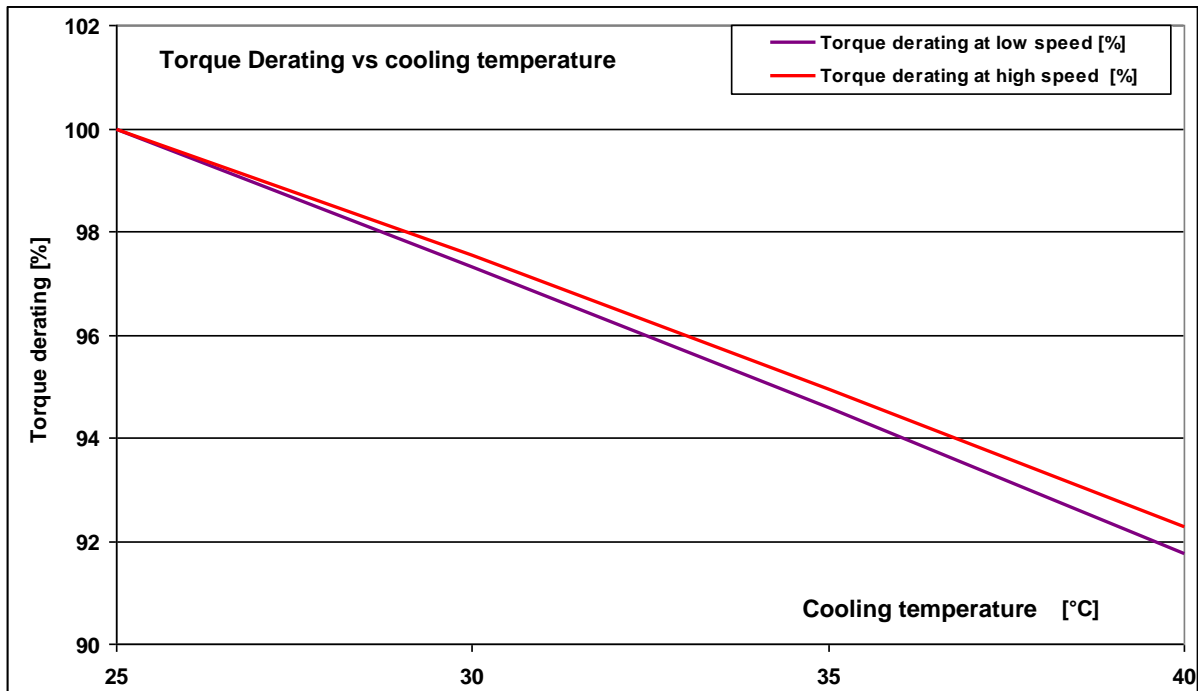
Let us consider:

- the period of the cycle T [s],
- the successively samples of movements i characterized each ones by the maximal torque M_i [Nm] reached during the duration Δt_i [s].

So, the rms torque M_{rms} can be calculated through the following basic formula:

$$M_{rms} = \sqrt{\frac{1}{T} * \sum_{i=1}^n M_i^2 \Delta t_i}$$

Example:

For a cycle of 2s at 0 Nm and 2s at 10Nm and a period of 4 s, the rms torque is

$$M_{rms} = \sqrt{\frac{1}{4} * 10^2 * 2} = 7,07 Nm$$

Illustration :

Acceleration-deceleration torque:10 Nm during 0.1 s. Resistant torque: 1 Nm during the movement.

Max-min speed: ± 2800 rpm during 0.2 s. Max torque provided by the motor 11 Nm. rms torque: 6 Nm.

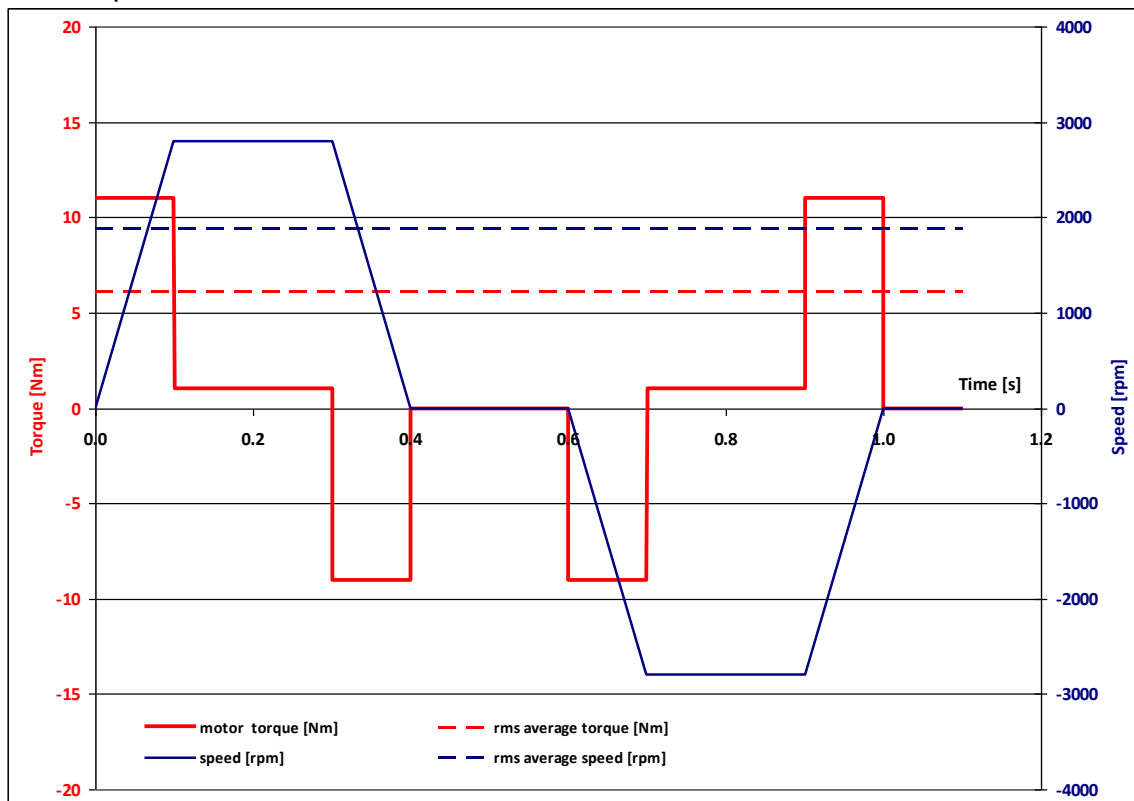

The maximal torque M_i delivered by the motor at each segment i of movement is obtained by the algebraic sum of the acceleration-deceleration torque and the resistant torque. Therefore, M_{max} corresponds to the maximal value of M_i .

Selection of the motor :

The motor adapted to the duty cycle has to provide the rms torque M_{rms} at the rms speed(*) without extra heating. This means that the permanent torque M_n available at the average speed presents a sufficient margin regarding the rms torque M_{rms} .

$$\Omega_{rms} = \sqrt{\frac{1}{T} * \sum_{i=1}^n \Omega_i^2 \Delta t_i}$$

(*) rms speed is calculated thanks to the same formula as that used for the rms torque. The mean speed cannot be used (in general mean speed is equal to zero). Only use the rms speed.

Furthermore, each M_i and speed associated Ω_i of the duty cycle has to be located in the operational area of the torque vs speed curve.

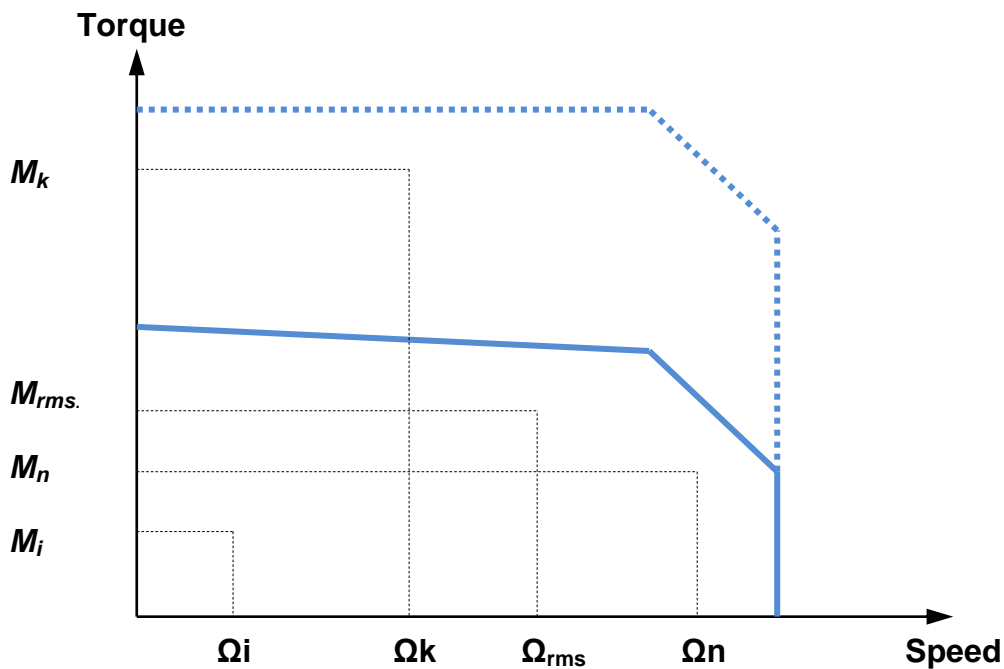

3.1.4. Drive selection

Drive selection depends on its rated power and its mode selection which leads to the maximal current duration.

	<p>Please refer to the drive technical documentation for any further information and to select the best motor and drive association.</p>
---	--

AC890 PARKER drive example:

The rated current provided by the AC890 drive depends on its rated power and its mode selection. “Vector mode” is used for induction motors while “Servo mode” is used for brushless AC motors. With NX motors the power is usually < 37 kW, the rated current corresponds to 100 %.

Power of Drive AC890 [kW]	< 37 kW	
Mode	Vector mode	Servo mode
Overload capability [%]	150 % during 60 s	200 % during 4 s

Illustration:

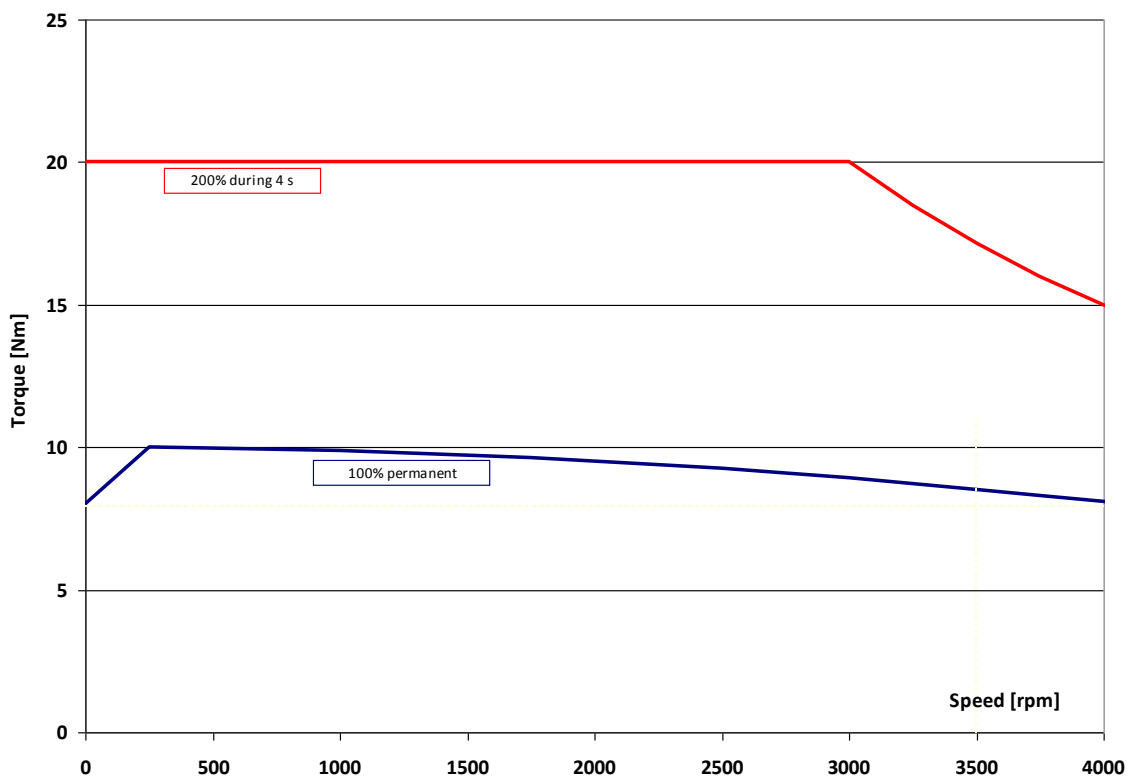



Example n°1 :

The application needs:

- a rms torque of **7 Nm** at the rms speed of **2000 rpm**,
- an acceleration torque of **12 Nm**,
- a maximal speed of **2800 rpm**.

Selection of the motor:

The selected motor is the type **NX620EAR**.

The nominal speed is equals to 3900 rpm.

The maximal speed is equals to 3900 rpm.

The torque sensitivity is equals to 1.47 Nm/Arms.

BRUSHLESS MOTORS			
NX620EAR			
ELECTRONIC DRIVE (1)			
DIGIVEX 7.5/15 et DIGIVEX 8/16			
	(230V) (400V) (480V)		

Torque at low speed	M_0	Nm	8		
Permanent current at low speed	I_0	A_{rms}	5.31		
Peak torque	M_p	Nm	26.7	--	
Current for the peak torque	I_p	A_{rms}	21.2	--	
Back emf constant at 1000 rpm (25°C)*	K_e	V_{rms}	95.7		
Torque sensitivity	K_t	Nm/A_{rms}	1.51		
Winding resistance (25°C)*	R_b	Ω	2.24		
Winding inductance*	L	mH	19.2		
Rotor inertia	J	$kgm^2 \times 10^{-5}$	98		
Thermal time constant	T_{th}	min	27		
Motor mass	M	kg	7		
Voltage of the mains	UR1 UR2 UR3	V_{rms}	230	400	480
Rated speed	Nn1 Nn2 Nn3	rpm	2200	3900	4500
Rated torque	Mn1 Mn2 Mn3	Nm	7.42	6.17	5.57
Rated current	In1 In2 In3	A_{rms}	4.99	4.25	3.89
Rated power	Pn1 Pn2 Pn3	W	1710	2520	2620

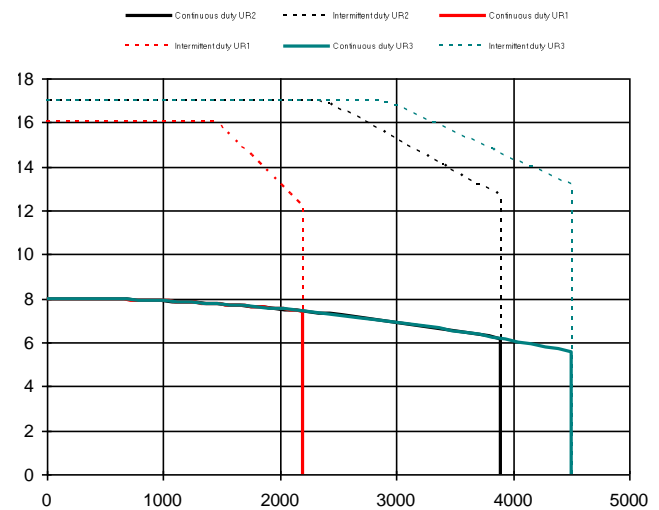

The permanent current I_0 of the motor is **5.31 Arms** for $M_0=8$ Nm at low speed.

The nominal current I_n of the motor is **4.25 Arms** for $M_n=6.17$ Nm at the nominal speed.

Selection of the drive:

The drive has to provide at least a permanent current equals to I_0 (5.31 Arms).

In order to obtain an acceleration torque of **12 Nm**, the current will be about 8 Arms (the motor data sheet shows 17 Nm with 11.3 Arms). This means that the drive has to provide at least 8 Arms as transient current.

→ Therefore, we can select the drive **AC890SD-53 2100 B** which delivers under 400 VAC:

6 Arms as permanent current and

$6 \times 200\% = 12$ Arms as maximal transient current during 4 s.

The drive is set with **“Servo Mode”**.

→ We also can select the drive **DIGIVEX 8/16 Â** which delivers under 400 VAC:

5.6 Arms as permanent current and

$5.6 \times 200\% = 11.3$ Arms as maximal transient current during 2 s.



Example n°2 :

This times; the application needs :

- a permanent torque of **5.8 Nm** at low speed,
- a rms torque of **5.8 Nm** at the rms speed of **1890 rpm**,
- an acceleration torque of **8.8 Nm**,
- a maximal speed of **2800 rpm**.

Selection of the motor:

The selected motor is the type **NX620EAR**.

The nominal speed is equals to 3900 rpm.

The maximal speed is equals to 3900 rpm.

The torque sensitivity is equals to 1.47 Nm/Arms.

Selection of the drive:

The drive has to provide a permanent current equals to 4 Arms to obtain 5.8 Nm.

In order to obtain an acceleration torque of **8.8 Nm**, the current will be of about 6 Arms

This means that the drive has to provide at less 6 Arms as transient current.

Compared to the previous example n°1, it is now possible to decrease the size of drive.

→ Therefore, we can select the drive **AC890SD-53 1600 B** which delivers under 400 VAC:

4 Arms as permanent current and

4*200%=8 Arms as maximal transient current during 4 s.

The drive is set with "**Servo Mode**".

3.1.5. Current limitation at stall conditions (i.e. speed < 3 rpm)

Recommended reduced current at speed < 3 rpm:

$$I_{reduced} = \frac{1}{\sqrt{2}} * I_0 \cong 0.7 * I_0$$

	<p><u>Warning:</u> The current must be limited to the prescribed values. If the nominal torque has to be maintained at stop or low speed (< 3 rpm), imperatively limit the current to 70% of I_0 (permanent current at low speed), in order to avoid an excessive overheating of the motor.</p>
	<p>Please refer to the drive technical documentation for any further information and to choose functions to program the drive.</p>

3.1.6. Peak current limitations

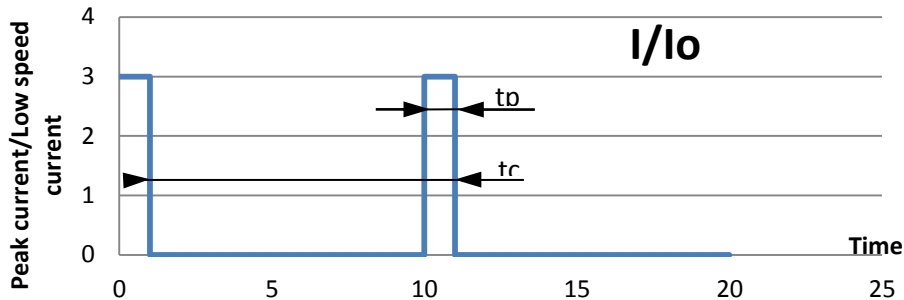

It is possible to use the NX motor with a current higher than the permanent current. But, to avoid any overheating, the following rules must be respected.

- 1) The peak currents and peak torques given in the data sheet must never be exceeded
- 2) The thermal equivalent torque must be respected (§3.1.3)
- 3) If 1) and 2) are respected (it can limit the peak current value or duration), the peak current duration (t_p) must be limited, in addition, accordingly to the following table (I_0 is the permanent current at low speed):

I_{peak}/I_n	$I_p/I_0 = 2$	$I_p/I_0 = 3$	$I_p/I_0 = 4$	$I_p/I_0 > 5$
NX110	$t_p < 0.8\text{ s}$	$t_p < 0.3\text{ s}$	$t_p < 0.15\text{ s}$	$t_p < 0.1\text{ s}$
NX210				
NX310				
NX420				
NX430	$t_p < 1.5\text{ s}$	$t_p < 0.6\text{ s}$	$t_p < 0.3\text{ s}$	$t_p < 0.2\text{ s}$
NX620				
NX630				
NX820				
NX840	$t_p < 3\text{ s}$	$t_p < 1.5\text{ s}$	not allowed	
NX860				
NX860V				
NX860W				

The peak current duration is calculated for a temperature rise of 3°C
Consult us for more demanding applications.

3.2. NX Characteristics: Torque, speed, current, power...

The torque vs speed graph below explains different intrinsic values of the next tables.

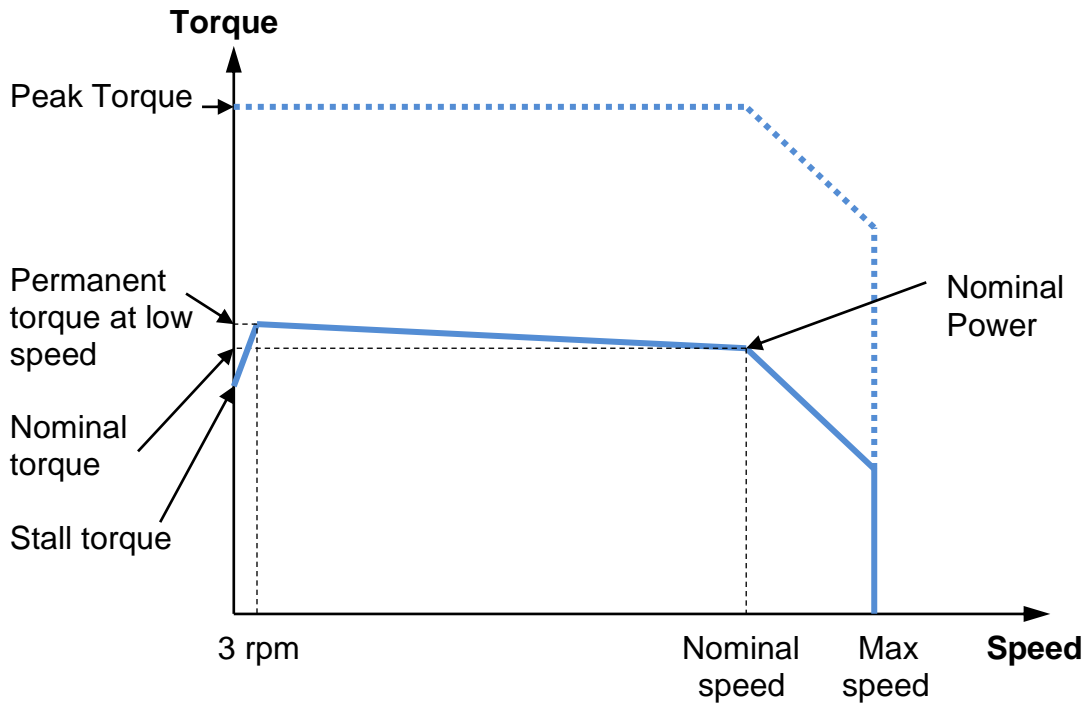





Motor	Electronic Drive	Torque at low speed	Current at low speed	Peak Torque	Peak current	Back emf constant at 1000rpm	Torque sensitivity	Winding resistance	Winding inductance	Rotor inertia	Voltage of the mains	Rated speed and max speed	Rated torque	Rated current	Rated power	UL version
Name	Type	Mo (Nm)	Io (Arms)	Mp (Nm)	Ip (Arms)	Ke (V)	Kt (Nm/A)	Rb (Ω)	L (mH)	J (10 ⁻⁶ .kg.m ²)	UR (V)	Nn (rpm)	Mn (Nm)	In (Arms)	Pn (W)	-
NX110AAJ	DRIVE 1 / 6 Arms	0,31	0,973	1,72	5,74	22,4	0,318	12	14,9	1,3	230	5000	0,09	0,34	50	Yes
NX110AAT	DRIVE 1 / 3 Arms	0,31	0,515	1,72	3,04	42,3	0,602	44,6	53,2	1,3	230	4000	0,15	0,27	60	Yes
NX110EAP	DRIVE 1 / 4 Arms	0,45	0,989	1,72	3,96	29,9	0,46	22,6	26,5	1,3	230	6000	0,33	0,78	210	NO
NX205AAV	DRIVE 1 / 5.5 Arms	0,4	0,908	2	5,5	30,2	0,44	17,6	46,4	2,1	400	6600	0,11	0,32	80	Yes
NX205EAV	DRIVE 1.5 / 6 Arms	0,45	1,01	2	5,08	30,2	0,44	17,6	46,4	2,1	400	7500	0,29	0,69	230	NO
NX205EAS	DRIVE 1.5 / 7.5 Arms	0,45	1,4	2	7,01	21,9	0,32	8,9	24,3	2,1	400	8900	0,23	0,80	210	NO
NX210AAT	DRIVE 1 / 6 Arms	0,7	1	3,4	5,58	48,6	0,7	16,3	35,0	3,8	400	6000	0,15	0,27	100	Yes
NX210EAT	DRIVE 1.5 / 6 Arms	1	1,33	3,4	5,35	48,6	0,75	16,3	35,0	3,8	400	6000	0,61	0,89	390	NO
NX210EAP	DRIVE 2 / 8 Arms	1	1,99	3,4	7,96	32,6	0,50	7,7	15,8	3,8	400	7000	0,50	1,11	370	NO
NX210EAG	DRIVE 3 / 11 Arms	1	2,75	3,4	11	23,6	0,36	3,9	8,3	3,8	400	7000	0,50	1,53	370	NO
NX310EAP	DRIVE 1.5 / 6 Arms	2	1,39	6,6	5,56	88,9	1,44	20,7	62,0	7,9	400	4000	1,65	1,18	690	Yes
NX310EAI	DRIVE 3.5 / 14 Arms	2	3,38	6,6	13,5	36,5	0,59	3,4	10,5	7,9	230	5600	1,48	2,61	870	NO
NX310EAK	DRIVE 2.5 / 10 Arms	2	2,43	6,6	9,71	50,9	0,82	6,6	20,3	7,9	400	7000	1,36	1,76	1000	Yes
NX310EAX	DRIVE 4 / 16 Arms	2	3,85	6,6	15,4	32,1	0,52	2,7	8,1	7,9	230	6600	1,32	2,71	910	Yes
NX420EAP	DRIVE 3 / 11 Arms	4	2,71	13,4	10,9	89,9	1,48	7,2	33,0	29	400	4000	3,14	2,16	1310	Yes
NX420EAV	DRIVE 1.5 / 6 Arms	4	1,36	13,4	5,47	179	2,94	28,4	131,0	29	400	2000	3,60	1,23	750	Yes
NX420EAX	DRIVE 6 / 22 Arms	4	5,42	13,4	21,8	44,9	0,74	1,8	8,2	29	400	7500	1,89	2,72	1490	NO
NX420EAJ	DRIVE 5 / 20 Arms	4	4,69	13,4	18,8	51,9	0,85	2,3	11,0	29	400	6000	2,62	3,17	1650	Yes
NX430EAV	DRIVE 1.5 / 6 Arms	5,5	1,41	18,8	5,64	244	3,90	29,0	151,0	42,6	400	1000	5,38	1,38	560	Yes
NX430EAP	DRIVE 3 / 12 Arms	5,5	2,82	18,8	11,3	122	1,95	7,3	37,8	42,6	400	3000	4,77	2,48	1500	Yes
NX430EAL	DRIVE 4 / 16 Arms	5,5	3,78	18,8	15,1	90,9	1,45	4,2	21,0	42,6	400	4000	4,29	3,01	1800	Yes
NX430EAF	DRIVE 7 / 27 Arms	5,5	6,64	18,8	26,5	51,8	0,83	1,4	6,8	42,6	400	6000	2,98	3,76	1870	Yes
NX430EAJ	DRIVE 6 / 22 Arms	5,5	5,24	18,8	21	65,6	1,05	2,2	10,9	42,6	400	5500	3,35	3,31	1930	Yes
NX430EAH	DRIVE 6 / 23 Arms	5,5	5,64	18,8	22,5	61	0,98	1,8	9,4	42,6	400	6000	2,98	3,19	1870	Yes



Motor	Electronic Drive	Torque at low speed	Current at low speed	Peak Torque	Peak current	Back emf constant at 1000rpm	Torque sensitivity	Winding resistance	Winding inductance	Rotor inertia	Voltage of the mains	Rated speed and max speed	Rated torque	Rated current	Rated power	UL version
Name	Type	Mo (Nm)	Io (Arms)	Mp (Nm)	Ip (Arms)	Ke (V)	Kt (Nm/A)	Rb (Ω)	L (mH)	J (10 ⁻⁵ .kg.m ²)	UR (V)	Nn (rpm)	Mn (Nm)	In (Arms)	Pn (W)	-
NX620EAR	DRIVE 6 / 22 Arms	8	5,31	26,7	21,2	95,7	1,51	2,2	19,2	98	400	3900	6,17	4,25	2520	Yes
NX620EAJ	DRIVE 10 / 40 Arms	8	9,89	26,7	39,5	51,3	0,81	0,6	5,5	98	400	5700	4,10	5,56	2450	Yes
NX620EAV	DRIVE 3 / 12 Arms	8	2,83	26,7	11,3	180	2,83	7,9	67,6	98	400	2000	7,52	2,69	1570	Yes
NX620EAD	DRIVE 13 / 50 Arms	8	12,1	26,7	48,3	42	0,66	0,4	3,7	98	400	6000	3,68	6,19	2310	NO
NX630EAR	DRIVE 6 / 22 Arms	12	5,25	40	21	138	2,29	2,4	24,9	147	400	2700	9,34	4,20	2640	Yes
NX630EAN	DRIVE 8 / 32 Arms	12	7,93	40	31,6	91,6	1,51	1,1	10,9	147	400	4000	7,60	5,30	3180	Yes
NX630EAV	DRIVE 3 / 11 Arms	12	2,62	40	10,5	277	4,57	9,2	99,6	147	400	1350	10,83	2,40	1530	Yes
NX630EAK	DRIVE 10 / 40 Arms	12	9,86	40	39,4	73,6	1,22	0,7	7,1	147	400	4900	6,23	5,53	3190	Yes
NX630EAG	DRIVE 14 / 56 Arms	12	13,9	40	55,6	52,1	0,86	0,3	3,5	147	230	4000	8,31	10,1	3480	NO
NX820EAX	DRIVE 6 / 21 Arms	16	5,16	50	20,3	193	3,10	4,5	38,7	320	400	1900	14,72	4,79	2930	Yes
NX820EAR	DRIVE 12 / 44 Arms	16	11	50	43,2	91	1,46	1,0	8,6	320	400	3900	12,94	9,07	5290	Yes
NX820EAL	DRIVE 18 / 70 Arms	16	17,6	50	69,1	56,9	0,91	0,4	3,4	320	400	6200	10,35	11,90	6720	NO
NX840EAQ	DRIVE 11 / 40 Arms	28	10,1	92	39,9	174	2,78	1,4	15,1	620	400	2100	23,17	8,47	5090	Yes
NX840EAL	DRIVE 16 / 60 Arms	28	15,1	92	59,8	116	1,85	0,6	6,7	620	400	3100	19,99	11,09	6490	Yes
NX840EAK	DRIVE 17 / 67 Arms	28	16,8	92	66,5	104	1,67	0,5	5,4	620	400	3500	18,56	11,51	6800	Yes
NX840EAJ	DRIVE 20 / 75 Arms	28	18,9	92	74,8	92,8	1,48	0,4	4,3	620	400	3900	17,04	11,99	6960	NO
NX860EAJ	DRIVE 20 / 75 Arms	41	18,5	137	74	140	2,21	0,5	6,4	920	400	2600	27,47	12,66	7480	Yes
NX860EAD	DRIVE 35 / 135 Arms	41	33	137	132	78,7	1,24	0,2	2,0	920	400	3200	21,89	18,19	7340	NO
NX860EAF	DRIVE 28 / 110 Arms	41	27	137	108	96,1	1,52	0,2	3,0	920	400	3200	21,89	14,88	7340	NO
NX860VAJ	DRIVE 30 / 75 Arms	64	29,3	137	74	140	2,18	0,5	6,4	920	400	2600	52,57	24,06	14310	Yes
NX860VAF	DRIVE 45 / 110 Arms	64	42,7	137	108	96,1	1,50	0,2	3,0	920	400	3750	43,38	28,93	17030	NO
NX860WAF	Drive 73 / 110 Arms	90	62,6	137	108	96,1	1,44	0,2	3,0	920	400	3750	85,1	59,1	33420	NO

3.2.1. Efficiency curves

	<p><u>Caution:</u> The efficiency curves are typical values. They may vary from one motor to an other</p>
---	---

	<p><u>Caution:</u> The efficiency curves are given for an optimal motor control (no voltage saturation and optimal phase between current and EMF)</p>
---	---

	<p><u>Caution:</u> The efficiency curves do not include the losses due to the switching frequency.</p>
--	--



3.2.1.1. Series NX110E

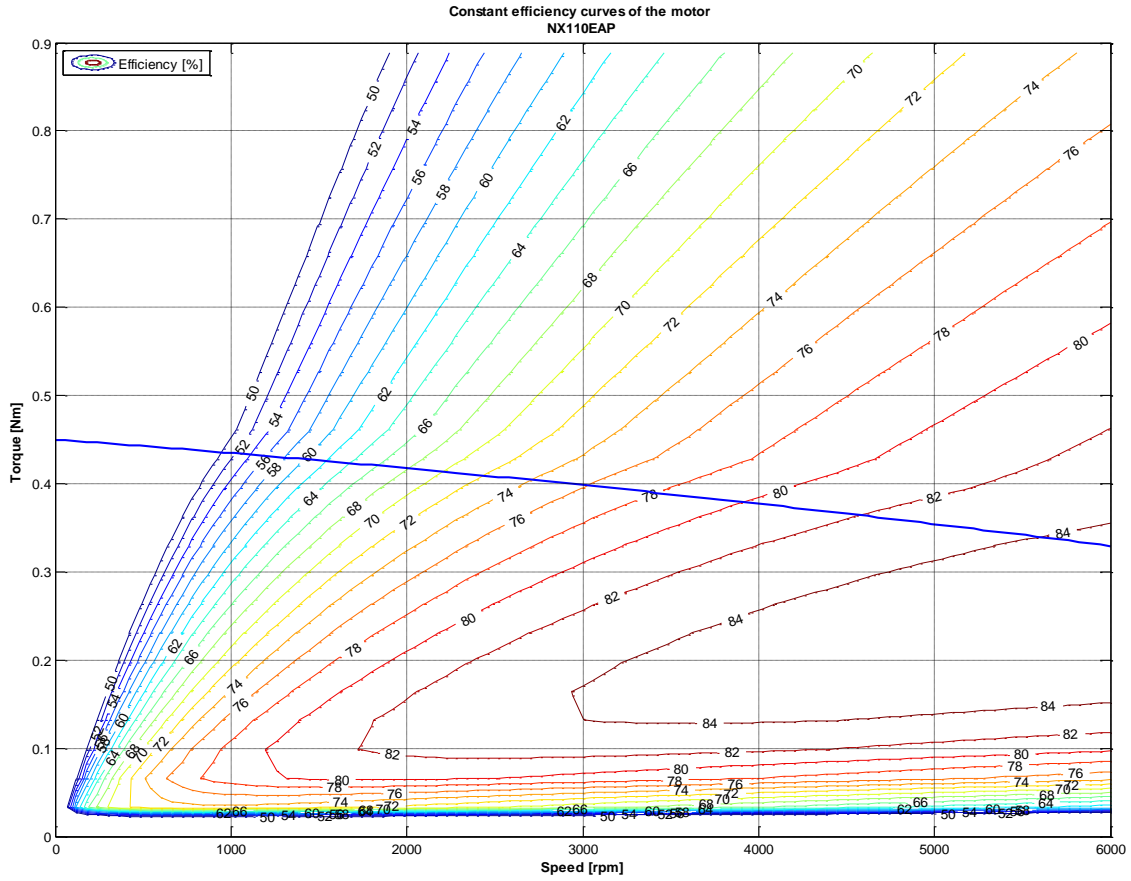

3.2.1.2. Series NX205E

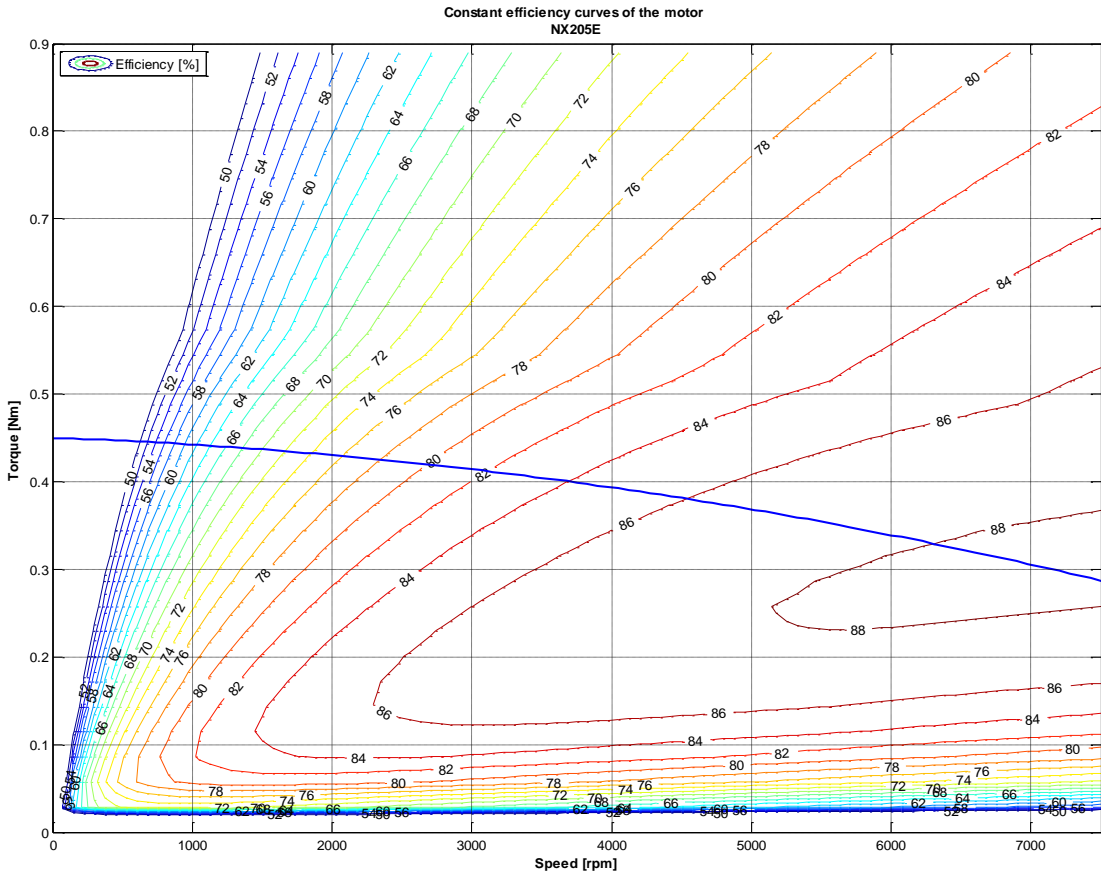



3.2.1.3. Series NX210E

Constant efficiency curves of the motor
NX210E

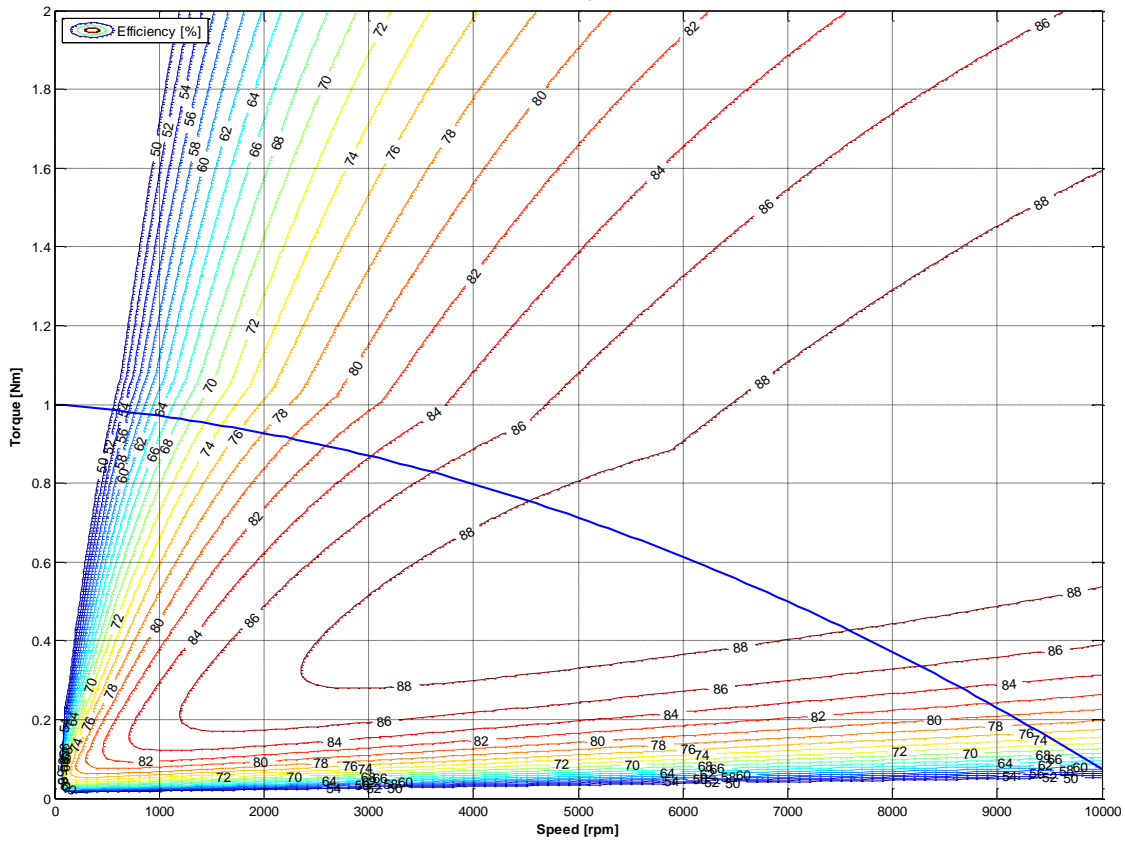

3.2.1.4. Series NX310E

Constant efficiency curves of the motor
NX310E

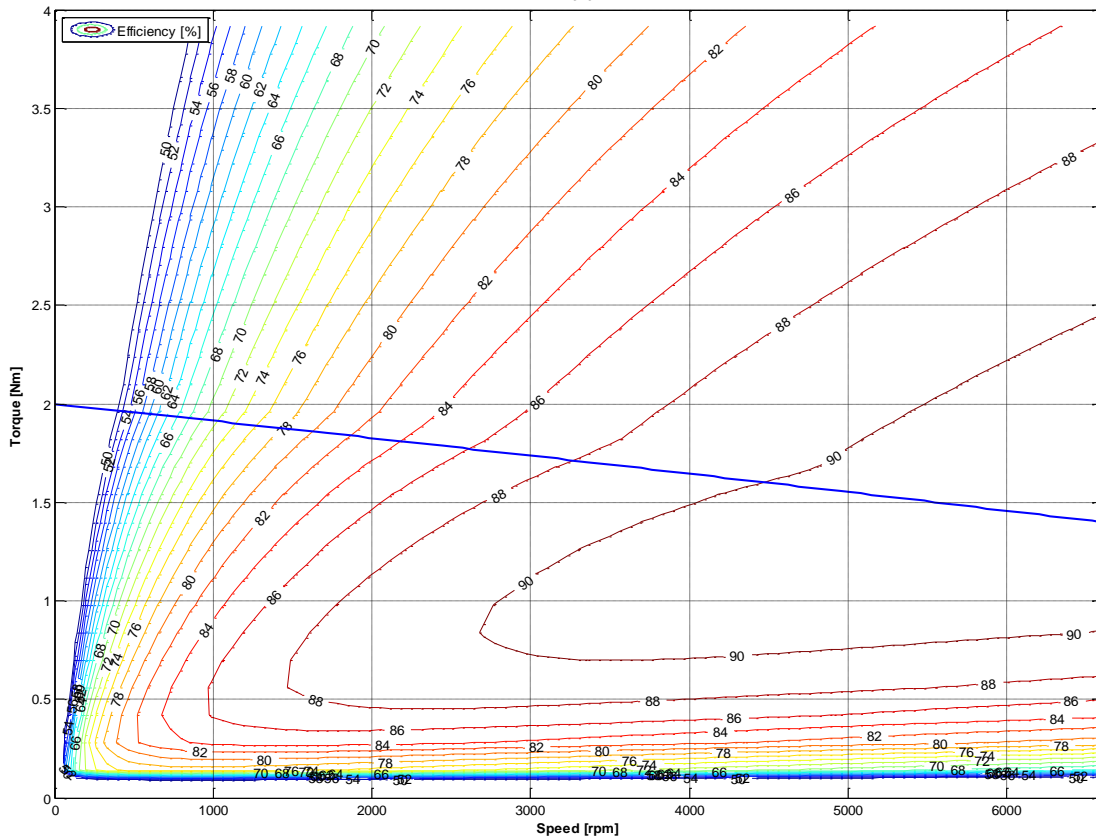

3.2.1.5. Series NX420E

Constant efficiency curves of the motor
NX420E

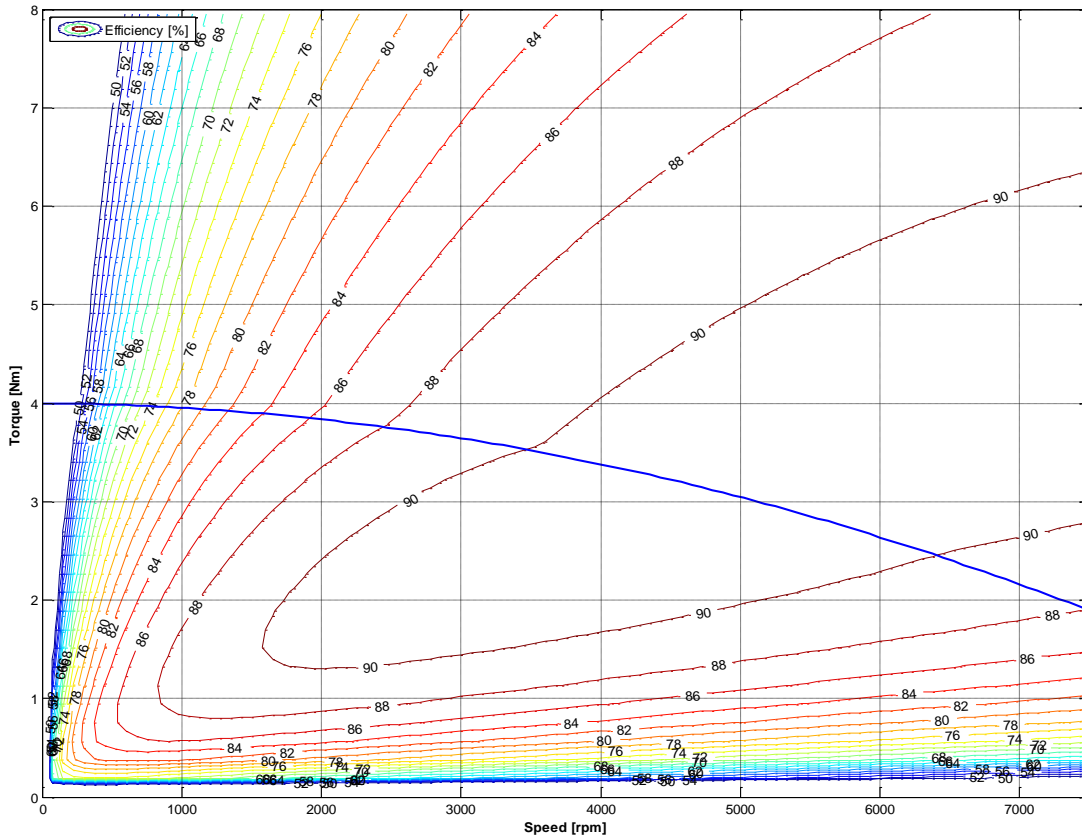

3.2.1.6. Series NX430E

Constant efficiency curves of the motor
NX430E

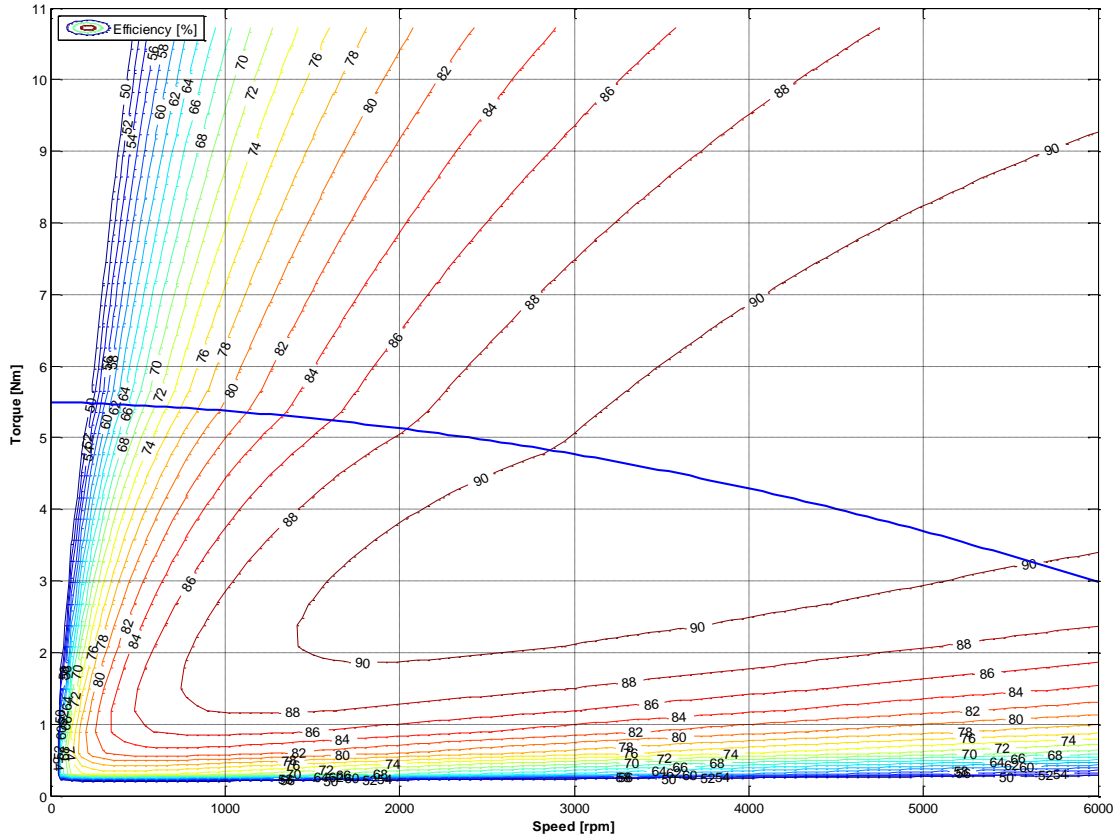



3.2.1.7. Series NX620E

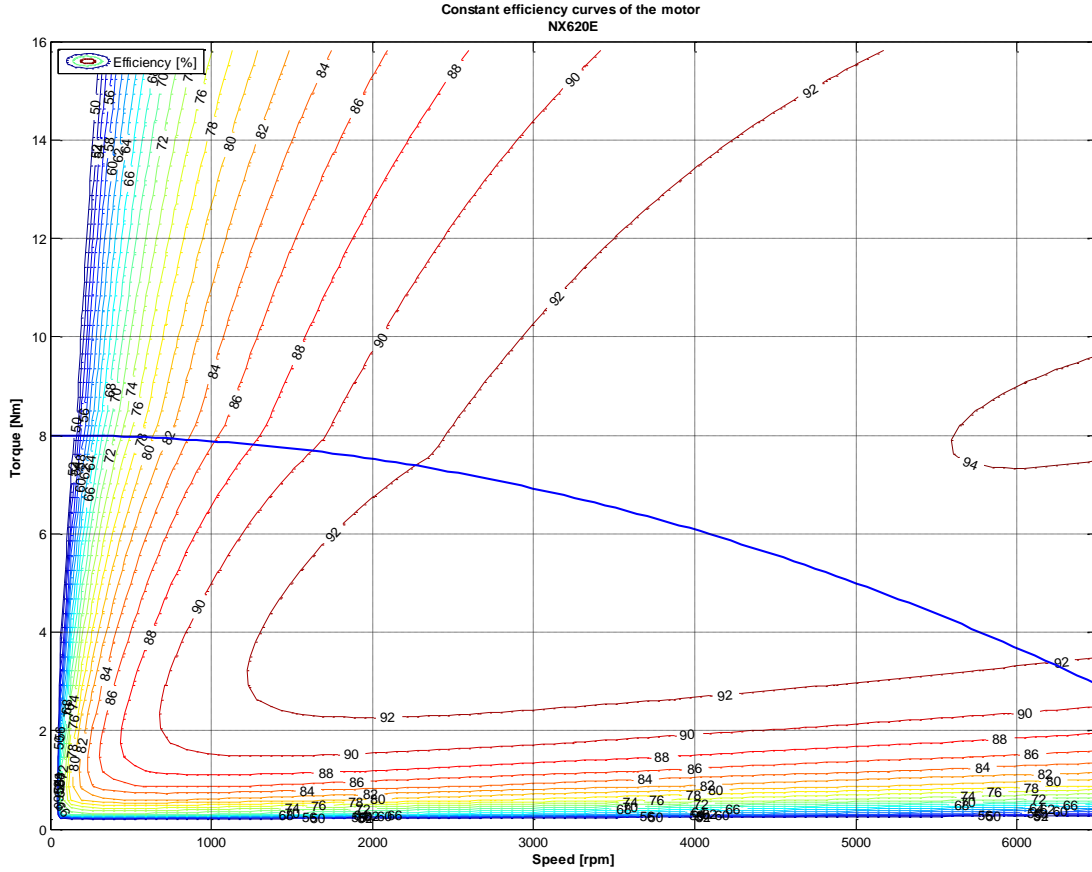

3.2.1.8. Series NX630E

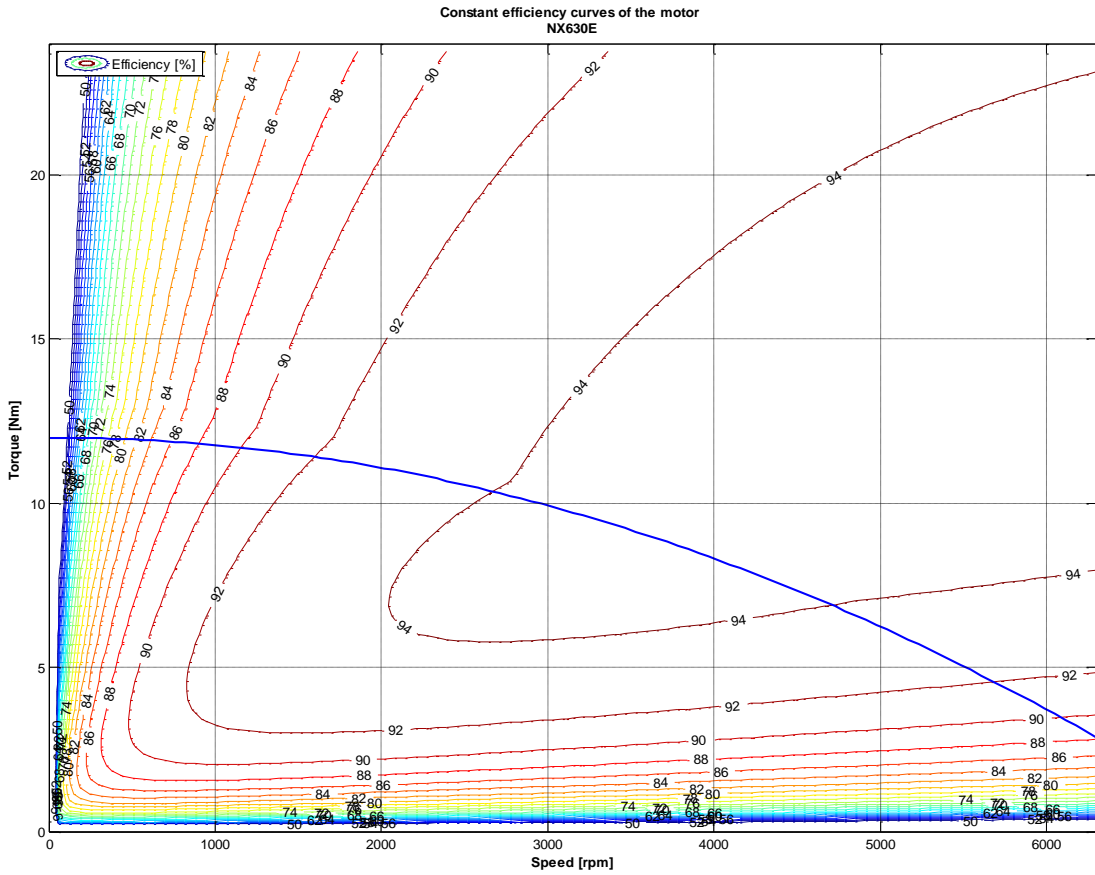

3.2.1.9. Series NX820E

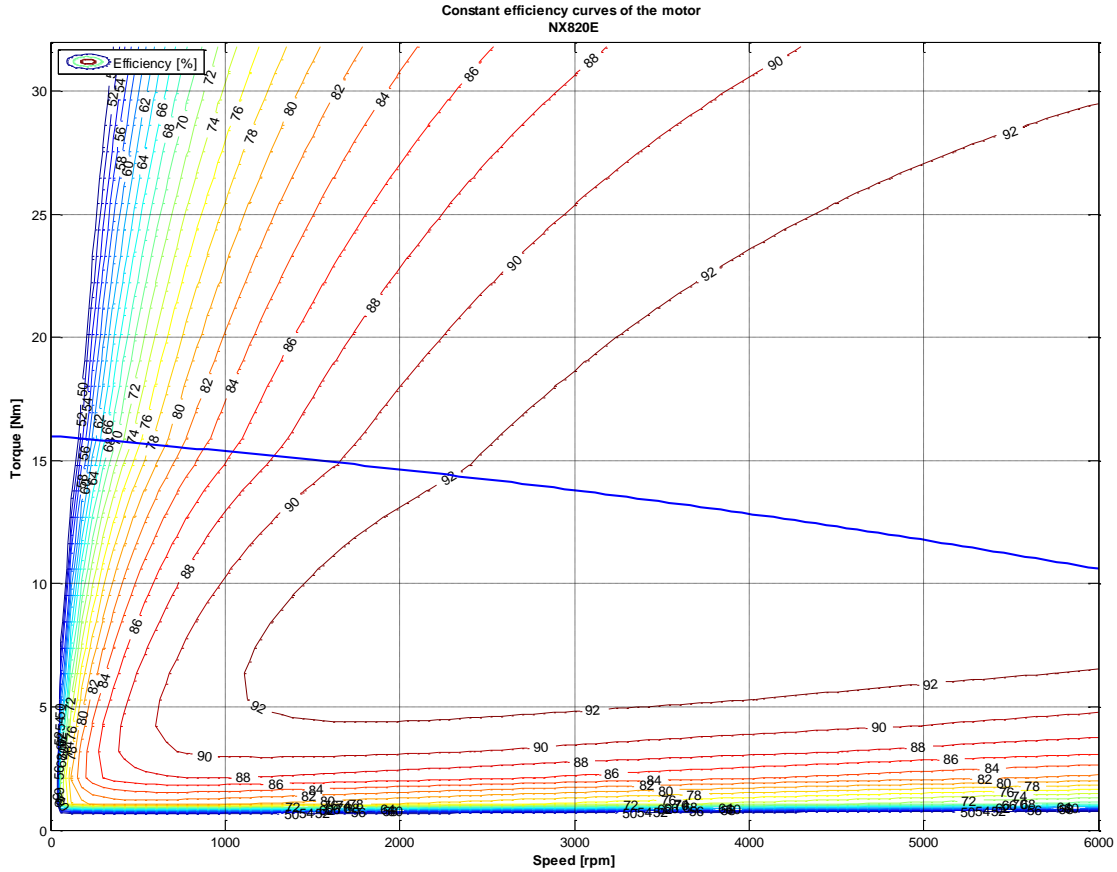

3.2.1.10. Series NX840E

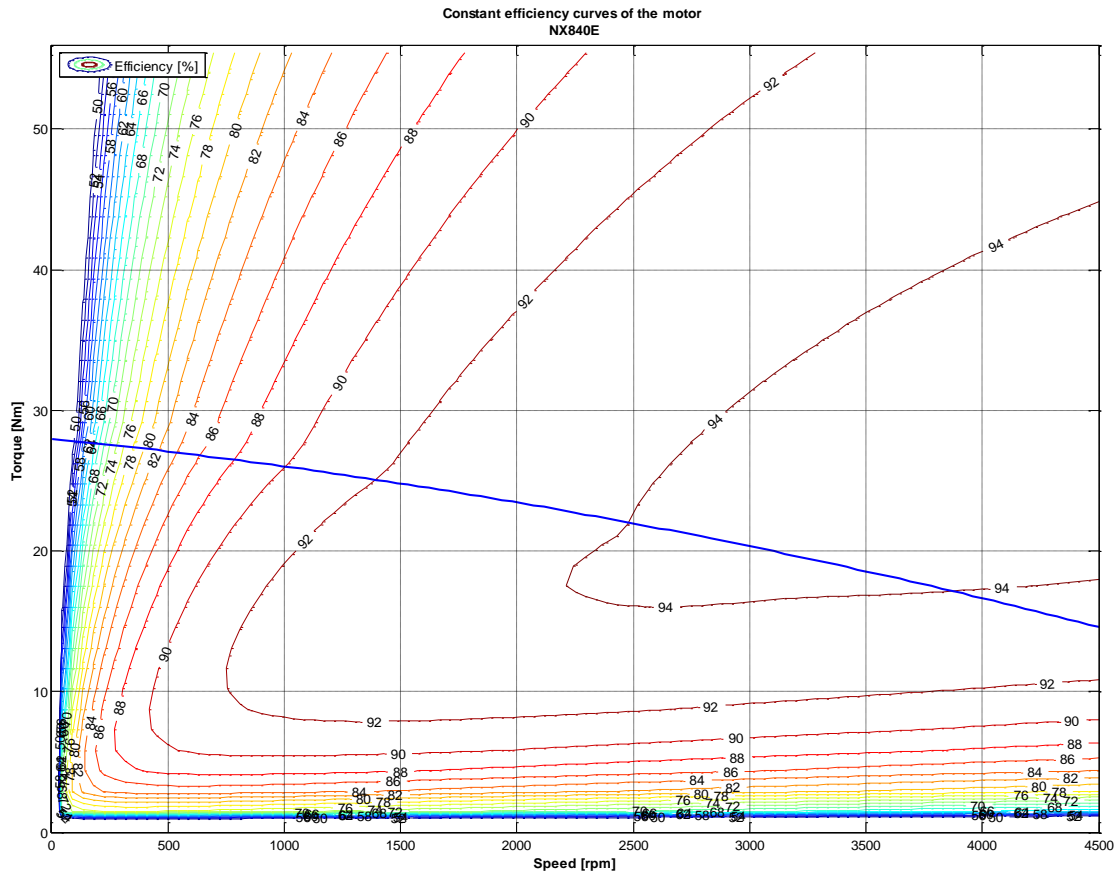

3.2.1.11. Series NX860E

Constant efficiency curves of the motor
NX860E

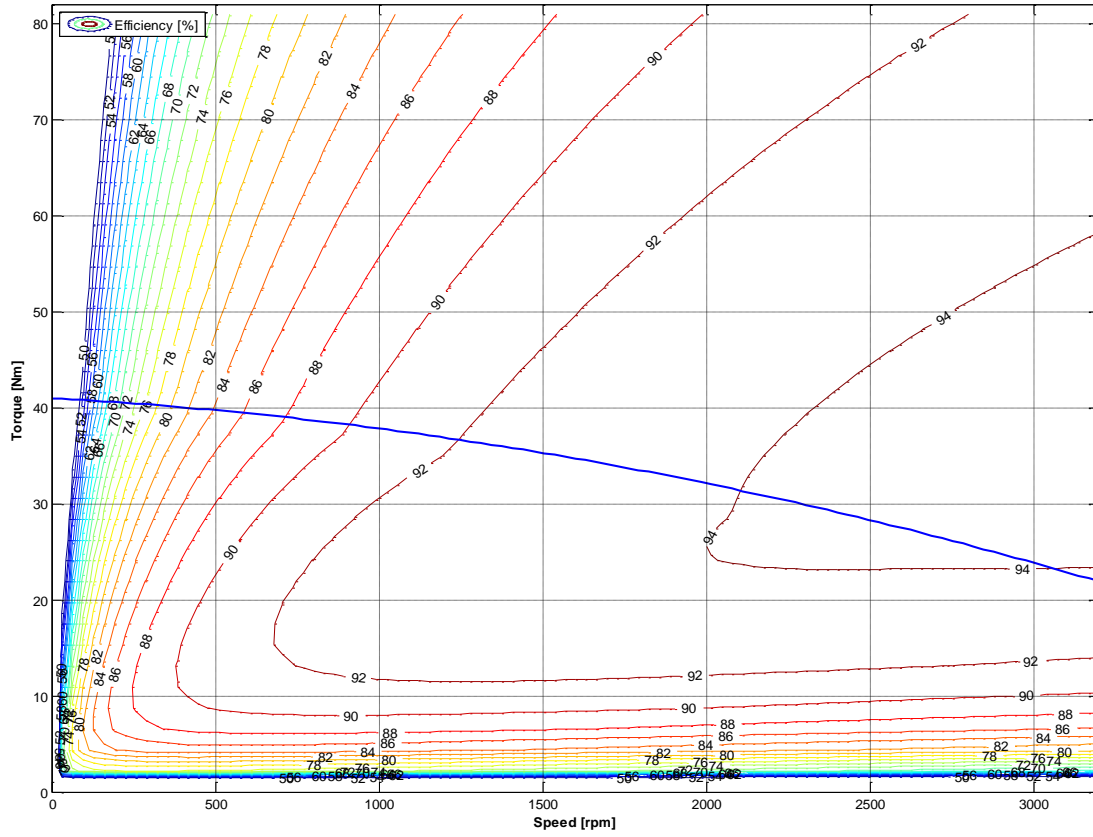

3.2.1.12. Series NX860V

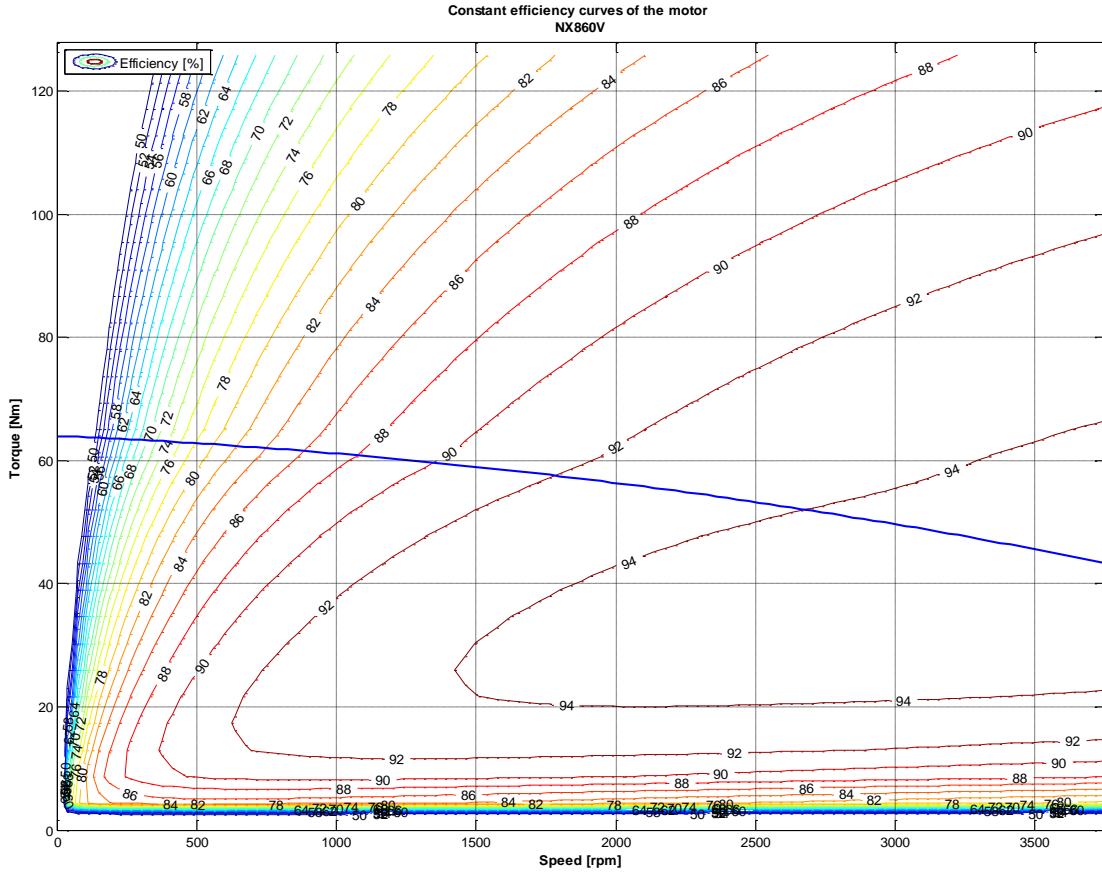

3.2.1.13. Series NX860W

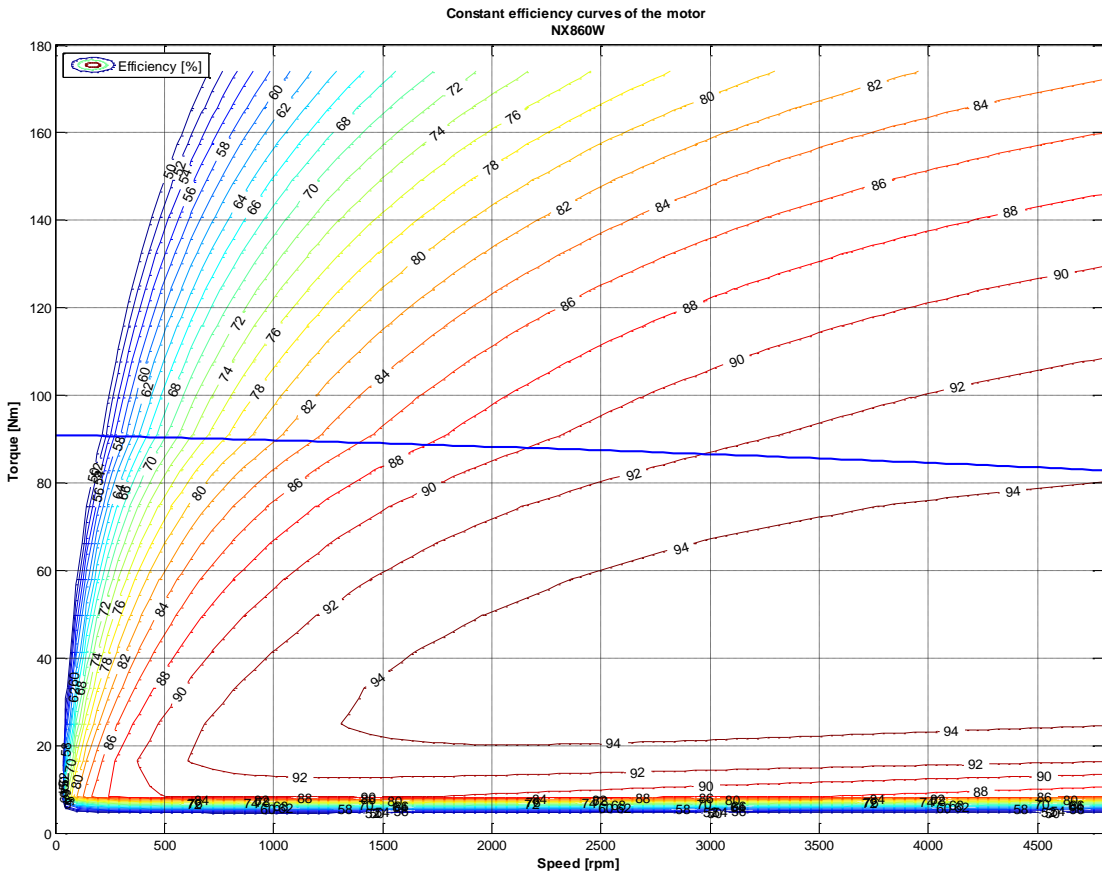

3.2.2. Electromagnetic losses

	<p><u>Caution:</u> Following data result from our best estimations but are indicative. They can vary from one motor to another and with temperature. No responsibility will be accepted for direct or indirect losses or damages due to the use of these data.</p>
---	--

(Following data are indicative)

Type	Tf [Nm]	Kd [Nm/1000rpm]
NX110EAP	0.010	0.004
NX205EAV	0.028	0.002
NX210EAP	0.013	0.007
NX310EAP	0.024	0.012
NX420EAP	0.045	0.013
NX430EAP	0.059	0.020
NX620EAR	0.080	0.034
NX630EAR	0.120	0.040
NX820EAR	0.104	0.083
NX840EAK	0.208	0.166
NX860EAJ	0.485	0.160
NX860VAJ	0.485	0.160

Torque losses = Tf + Kd x speed/1000

3.2.3. Time constants of the motor

3.2.3.1. Electric time constant:

$$\tau_{elec} = \frac{L_{ph_ph}}{R_{ph_ph}}$$

With following values given in the motor data sheet

L_{ph_ph} inductance of the motor phase to phase [H],

R_{ph_ph} resistance of the motor phase to phase at 25°C [Ohm].

Example:

Motor series NX620EAR

$L_{ph_ph} = 19.2 \text{ mH}$ or $19.2 \cdot 10^{-3} \text{ H}$

R_{ph_ph} at 25°C = 2.24 Ohm

→ $\sigma_{elec} = 19.2 \cdot 10^{-3} / 2.24 = 8.6 \text{ ms}$

An overall summary of motor time constants is given a little further.

3.2.3.2. Mechanical time constant:

$$\tau_{mech} = \frac{R_{ph_ph} * J}{Kt * Ke_{ph_ph}} = \frac{0.5 * R_{ph_ph} * J}{(3 * \frac{Ke_{ph_ph}}{\sqrt{3}}) * \frac{Ke_{ph_ph}}{\sqrt{3}}}$$

$$\tau_{mech} = \frac{0.5 * R_{ph_ph} * J}{(Ke_{ph_ph})^2}$$

With following values obtained from the motor data sheet:

R_{ph_ph} resistance of the motor phase to phase at 25°C [Ohm],

J inertia of the rotor [kgm²],

Ke_{ph_ph} back emf coefficient phase to phase [$V_{rms}/rad/s$].

The coefficient Ke_{ph_ph} in the formula above is given in [$V_{rms}/rad/s$]

To calculate this coefficient from the datasheet, use the following relation:

$$Ke_{ph_ph} [V_{rms}/rad/s] = \frac{Ke_{ph_ph} [V_{rms}/1000rpm]}{\frac{2 * \pi * 1000}{60}}$$

Example:

Motor series NX620EAR

R_{ph_ph} at 25°C = 2.24 Ohm

$J = 98 \cdot 10^{-5} \text{ kgm}^2$

$Ke_{ph_ph} [V_{rms}/1000rpm] = 95.7 [V_{rms}/1000rpm]$

→ $Ke_{ph_ph} [V_{rms}/rad/s] = 95.7 / (2 * \pi * 1000 / 60) = 0.9139 [V_{rms}/rad/s]$

→ $\sigma_{mech} = 0.5 * 2.24 * 98 \cdot 10^{-5} / (0.9139^2) = 1.2 \text{ ms}$

Remarks:

For a DC motor, the mechanical time constant σ_{mech} represents the duration needed to reach 63% of the final speed when applying a voltage step without any resistant torque. However this value makes sense only if the electric time constant σ_{elec} is much smaller than the mechanical time constant σ_{mech} (for the motor NX620EAR taken as illustration, it is not the case because we obtain $\sigma_{mech} < \sigma_{elec}$).

An overall summary of motor time constants is given a little further.

3.2.3.3. Thermal time constant of the copper:

$$\tau_{therm} = Rth_{copper_iron} * Cth_{copper}$$

$$Cth_{copper [J/^{\circ}K]} = Mass_{copper [kg]} * 389_{[J/kg^{\circ}K]}$$

With:

Rth_{copper_iron} thermal resistance between copper and iron [$^{\circ}K/W$]

Cth_{copper} thermal capacity of the copper [$J/^{\circ}K$]

$Mass_{copper}$ mass of the copper (winding) [kg]

Hereunder is given an overall summary of motor time constants:

Type	Electric time constant [ms]	Mechanical time constant [ms]	Thermal time constant of copper [s]
NX110EAP	1.2	0.5	3.0
NX205EAV	2.6	0.6	7.9
NX210EAP	2.0	0.5	5.6
NX310EAP	3.0	1.0	11.6
NX420EAP	4.6	1.2	31.1
NX430EAP	5.2	1.3	32.6
NX620EAR	8.6	1.2	59.5
NX630EAR	10.2	1.3	53.9
NX820EAR	8.5	1.9	67.3
NX840EAK	11.0	1.5	29.9
NX860EAJ	12.9	1.7	28.1
NX860VAJ	12.9	1.7	28.1



3.2.4. Speed ripple

The typical speed ripple for a NX motor with a resolver at 4000rpm is 3% peak to peak.

This value is given as indicative data because depending on the settings of the drive (gains of both speed and current regulation loops, presence of filtering or not, load inertia, resistant torque and type of sensor in use), without external load (neither external inertia nor resistant torque).

3.2.5. Rated data according to rated voltage variation

The nominal characteristics and especially the rated speed, maximal speed, rated power, rated torque, depend on the nominal voltage supplying the motor considered as the rated voltage. The rated data mentioned in the data sheet are given for each association of motor and drive. Therefore, if the supply voltage changes, the rated values will also change. As long as the variation of the rated voltage remains limited, for instance $\pm 10\%$ of the nominal value, it is possible to correctly evaluate the new rated values as illustrated below.

Example:

Extract of NX620EAR datasheet

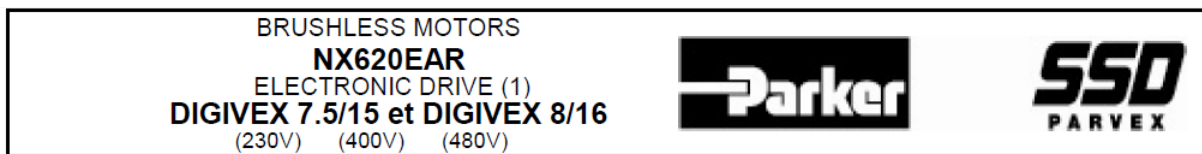

Torque at low speed	M_o	Nm	8		
Permanent current at low speed	I_o	A_{rms}	5.31		
Peak torque	M_p	Nm	26.7		
Current for the peak torque	I_p	A_{rms}	21.2		
Back emf constant at 1000 rpm (25°C)*	K_e	V_{rms}	95.7		
Torque sensitivity	K_t	Nm/A_{rms}	1.51		
Winding resistance (25°C)*	R_b	Ω	2.24		
Winding inductance*	L	mH	19.2		
Rotor inertia	J	$kgm^2 \times 10^{-5}$	98		
Thermal time constant	T_{th}	min	27		
Motor mass	M	kg	7		
Voltage of the mains	UR1 UR2 UR3	V_{rms}	230	400	480
Rated speed	$N_{n1} N_{n2} N_{n3}$	rpm	2200	3900	4500
Rated torque	$M_{n1} M_{n2} M_{n3}$	Nm	7.42	6.17	5.57
Rated current	$I_{n1} I_{n2} I_{n3}$	A_{rms}	4.99	4.25	3.89
Rated power	$P_{n1} P_{n2} P_{n3}$	W	1710	2520	2620

□ If we suppose that the rated voltage $U_n=400 V_{rms}$ decreases of **10%** ; this means that the new rated voltage becomes $U_{n2}=360 V_{rms}$.

Rated speed:

The former rated speed $N_n=3900$ rpm obtained with a rated voltage $U_n=400 V_{rms}$ and an efficiency of $\eta=92\%$ leads to the new rated speed N_{n2} given as follows:

$$N_{n2} = N_n * \frac{\frac{U_{n2}}{U_n} - 1 + \eta}{\eta} \qquad N_{n2} = 3900 * \frac{\frac{360}{400} - 1 + 0.92}{0.92} = 3476rpm$$

Maximum speed:

The former maximum speed $N_{\max} = 3900$ rpm obtained with $U_n = 400$ V_{rms} and $N_n = 3900$ rpm leads to the new maximum speed $N_{\max 2}$ given as follows:

$$N_{\max 2} = N_{\max} * \frac{N_{n2}}{N_n} \qquad N_{\max 2} = 3900 * \frac{3476}{3900} = 3476 \text{rpm}$$

N.B.

□ If the rated voltage increases ($U_{n2} > U_n$), the new rated speed N_{n2} and the new maximum speed $N_{\max 2}$ will be greater than the former ones N_n and N_{\max} . Moreover you will have to check that the drive still shows able to deal with the new maximum electric frequency.

	<p><u>Warning:</u> If the main supply decreases, you must reduce the maximum speed accordingly in order not damage the motor. In case of doubt, consult us.</p>
---	---

Rated power:

The former rated power $P_n = 2520$ W obtained with $U_n = 400$ V_{rms} leads to the new rated power P_{n2} given as follows:

$$P_{n2} = P_n * \frac{U_{n2}}{U_n} \qquad P_{n2} = 2520 * \frac{360}{400} = 2268 \text{W}$$

Rated torque:

The former rated torque $M_n = 6.17$ Nm obtained with $U_n = 400$ V_{rms} leads to the new rated torque M_{n2} given as follows:

$$M_{n2} = \frac{P_{n2}}{2 * \pi * N_{n2}} \qquad M_{n2} = \frac{2268}{2 * \pi * 3476} = 6.23 \text{Nm}$$

3.2.6. Voltage withstand characteristics of NX series

The motors fed by converters are subject to higher stresses than in case of sinusoidal power supply. The combination of fast switching inverters with cables will cause overvoltage due to the transmission line effects. The peak voltage is determined by the voltage supply, the length of the cables and the voltage rise time. As an example, with a rise time of 200 ns and a 30 m (100 ft) cable, the voltage at the motor terminals is twice the inverter voltage.

The insulation system of the servomotors NX is designed to withstand high repetitive pulse voltages and largely exceeds the recommendations of the IEC/TS 60034-25 ed 2.0 2007-03-12 for motors without filters up to 500V AC (See figure 1).

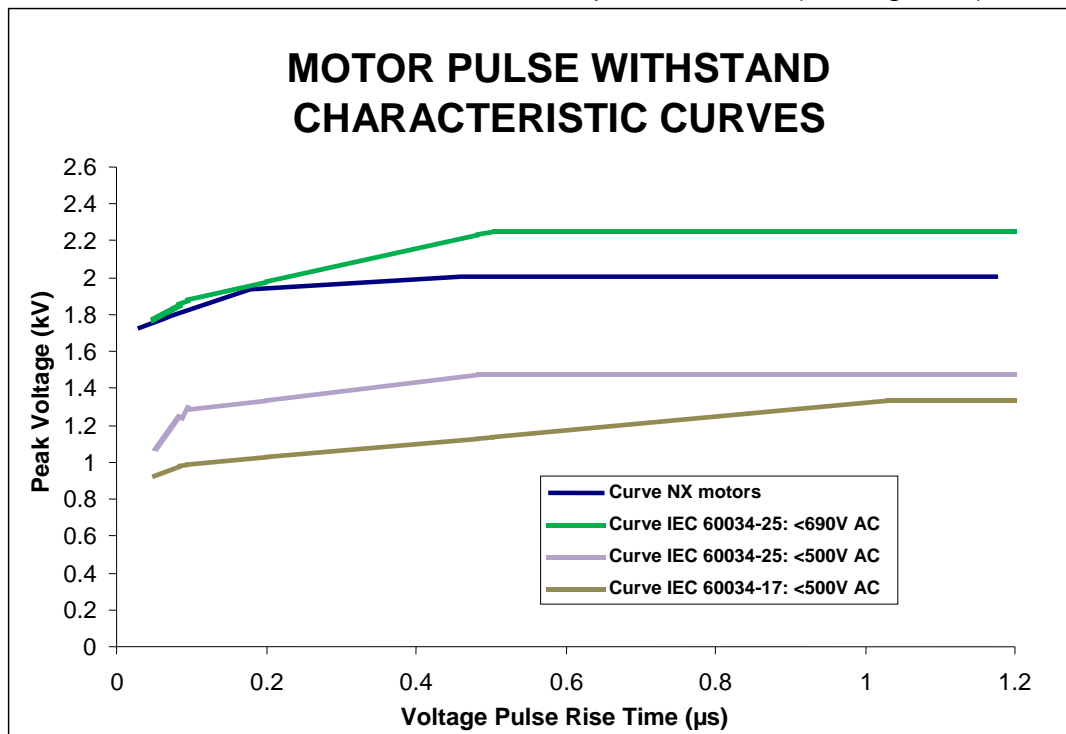

Figure 1: Minimum Voltage withstands characteristics for motors insulations according to IEC standards. At the top are the typical capabilities for the NX motors.

Note: The pulse rise times are defined in accordance with the IEC/TS 60034-17 ed4.0 2006-05-09.

The NX motors can be used with a supply voltage up to 500 V under the following conditions:

- The pulse rise times must be longer than 50 ns.
- The repetitive pulse voltages must not exceed the values given in figure 1, “Curve NX motors” in dark blue.

3.3. Dimension drawings

3.3.1. NX1

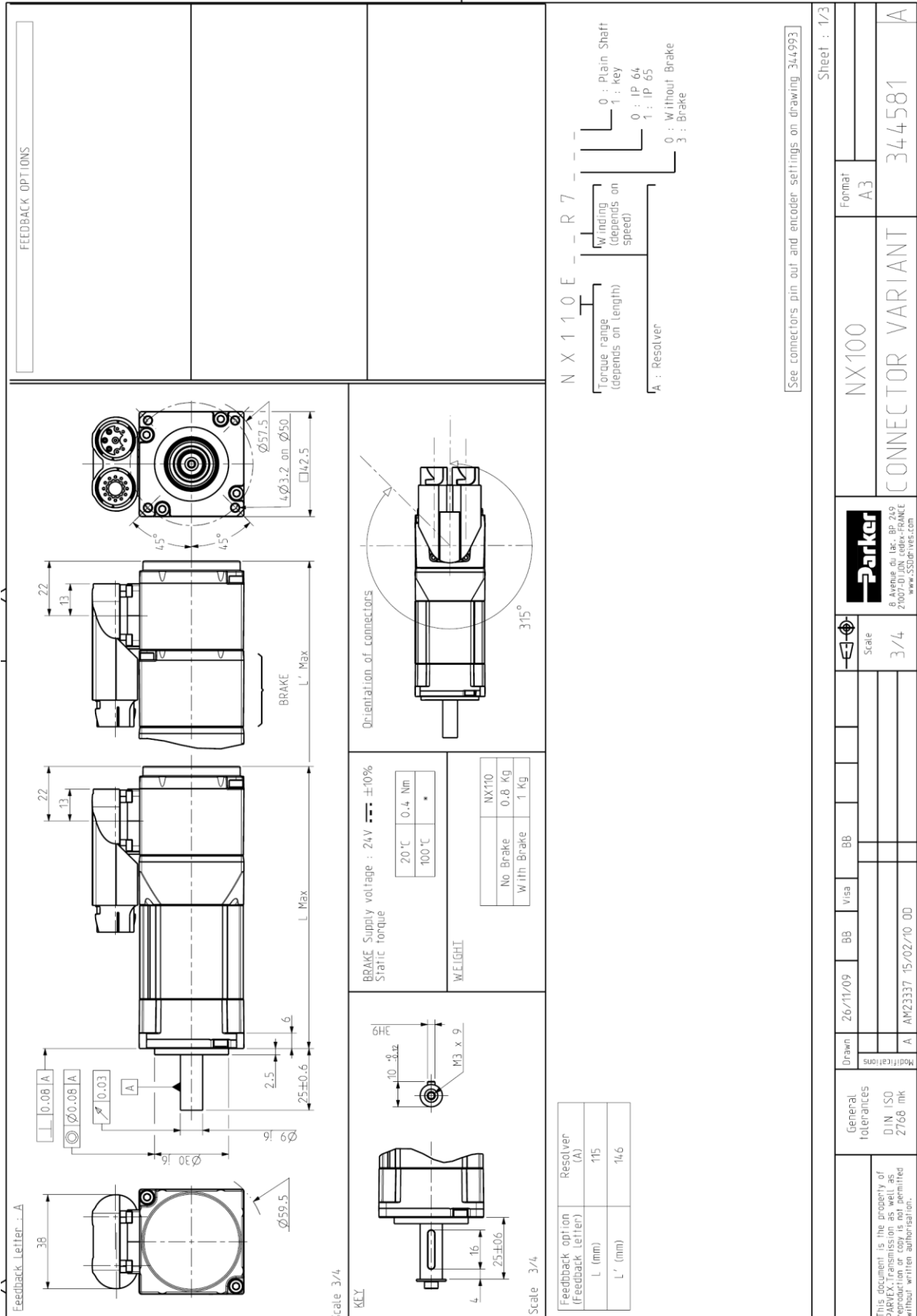

Feedback Letter : A

Scale 3/4

Feedback Letter : Y

Scale 1/4

Feedback Letter : A

Scale 3/4

Feedback Letter : Y

Scale 1/4

Feedback Letter : A

Scale 3/4

Feedback Letter : Y

Scale 1/4

Feedback Letter : A

Scale 3/4

FEEDBACK LETTER ... Y

Scale 1/4

Feedback Options

BRAKE Supply voltage : 24V ±10%
Static torque

20 °C	0.4 Nm
100 °C	*

W E I G H T

No Brake	NX10
With Brake	0.8 Kg
	1 Kg

KEY

Scale 3/4

Feedback option (Feedback Letter)

Feedback option (Feedback Letter)	Resolver (A)	Sensorless (Y)
L (mm)	134	110
L' (mm)	165	141

N X 1 1 0 E - R 1

Torque range (depends on length)

Winding (depends on speed)

A : Resolver
Y : Sensorless

0 : Plain Shaft
1 : key
0 : IP 64
1 : IP 65
0 : Without Brake
3 : Brake

[See wire connection and encoder settings on drawing 344993]

Sheet : 3/3

General tolerances
DIN ISO 2768 mk

Drawn 26/11/09 BB Visa
Modifications

Scale 3/4

Format A3

NX100
CABLE VARIANT

344581

Format A

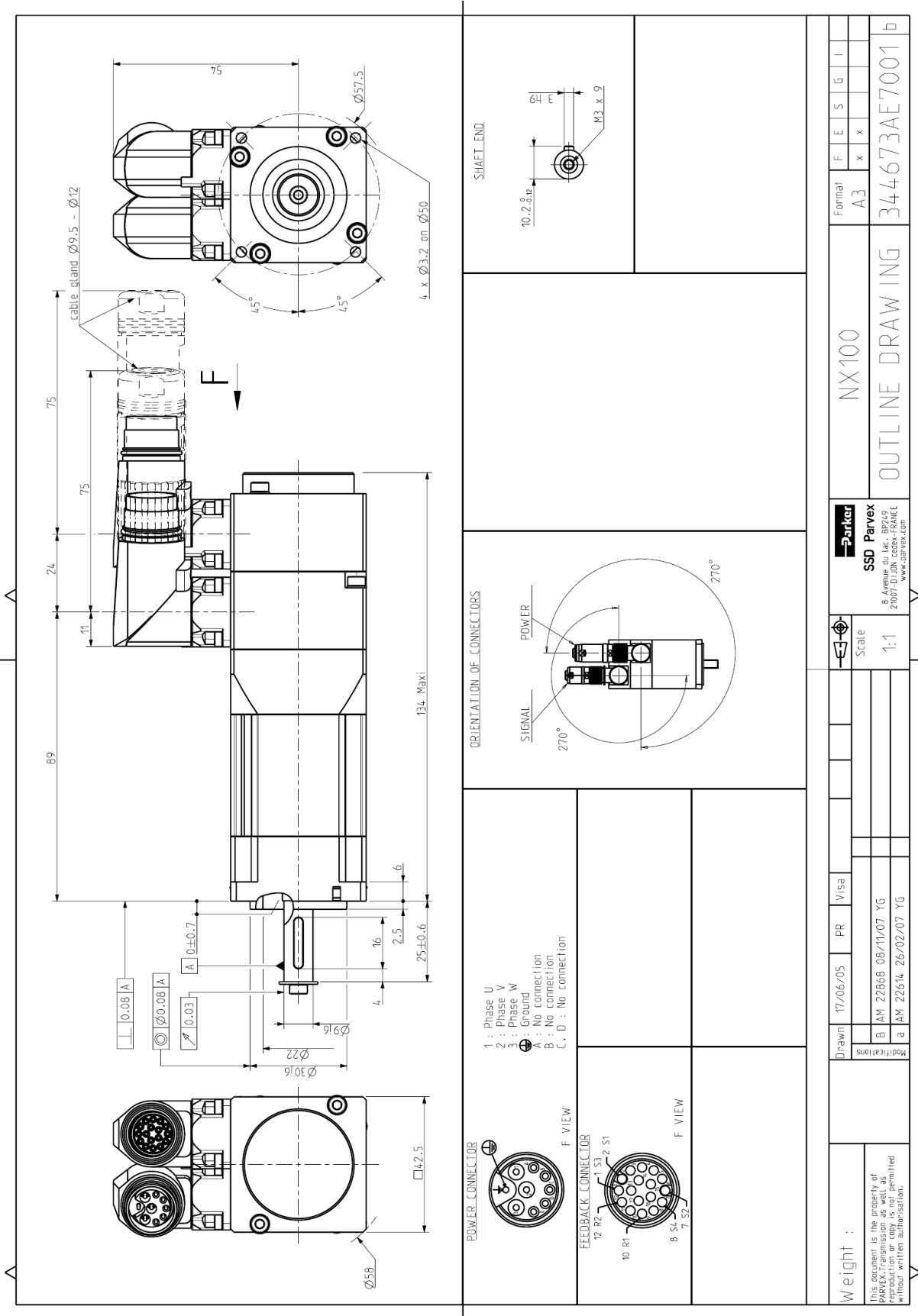

Weight :	Drawn	17/06/05	PR	V/isa	Scale	1:1	SSD Parvex B Avenue du Lac, BP249 20007-DIJON cedex-FRANCE www.parker.com	NX100	Format	F	E	S	G	I
		B AM 22668 08/11/07 YG	AM 22614 26/02/07 YG	A3						x	x	x	x	x
This document is the property of PARKEX. Reproduction or copy is not permitted without written authorisation.										OUTLINE DRAWING				
										344673AE7001				

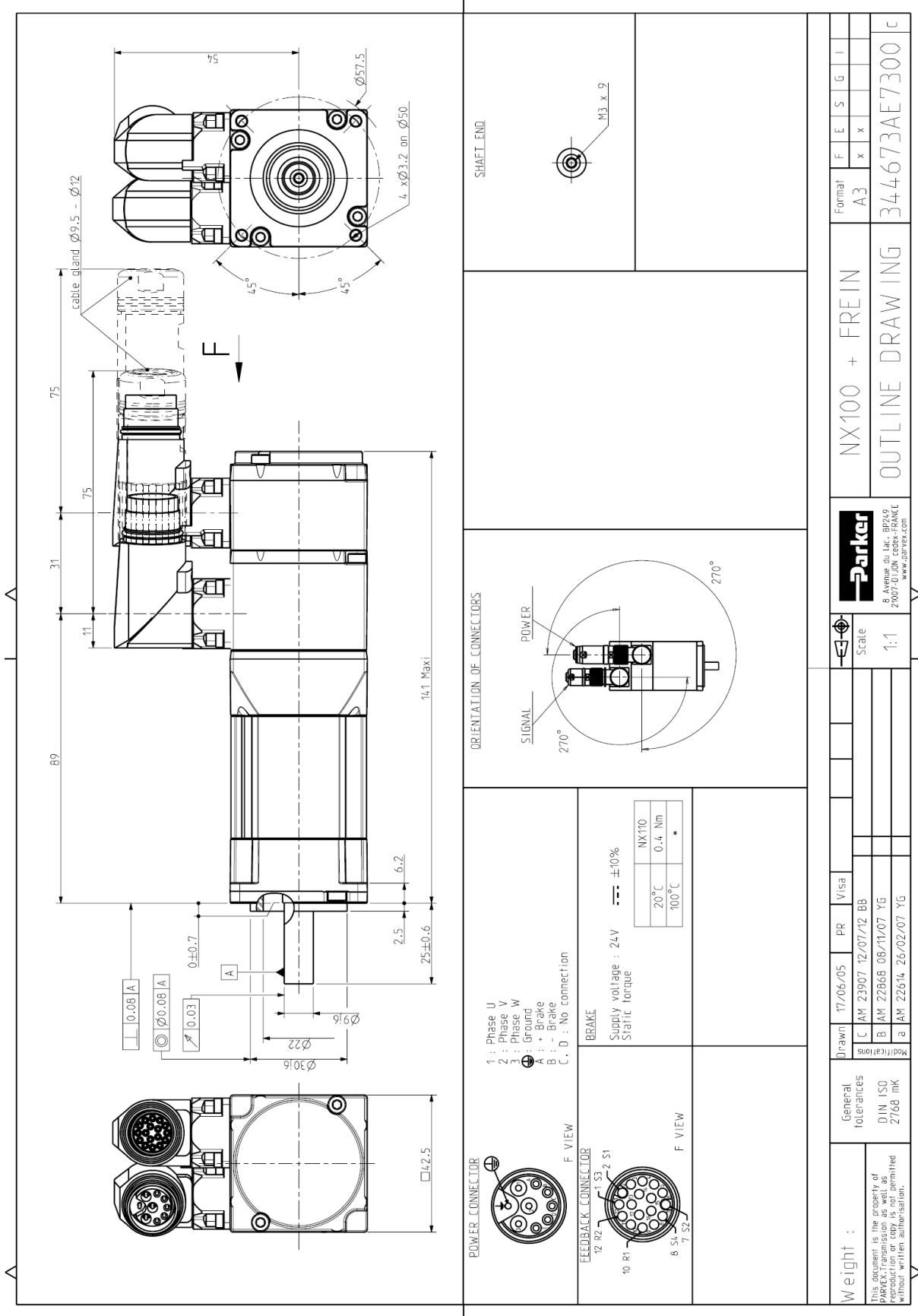

- 1 : Phase U
- 2 : Phase V
- 3 : Phase W
- ⊕ : Ground
- A : + Brake
- B : - Brake
- C, D : No connection

POWER CONNECTOR	BRAKE
Supply voltage : 24V	Static torque
20°C	NX100
100°C	0.4 Nm
	*

Format	F	E	S	G	I
A3	x	x	x	x	x

NX100 + FREIN
OUTLINE DRAWING



Scale
1:1

Drawn	17/06/05	PR	Visa
Rev	C AM 23907 12/07/12 BB		
	B AM 22868 08/11/07 YG		
	a AM 22614 26/02/07 YG		

General Tolerances
DIN ISO 2768 mK

Weight :

This document is the property of PARKEX-Transmission as well as its reproduction or copy is not permitted without written authorisation.

3.3.3. NX2

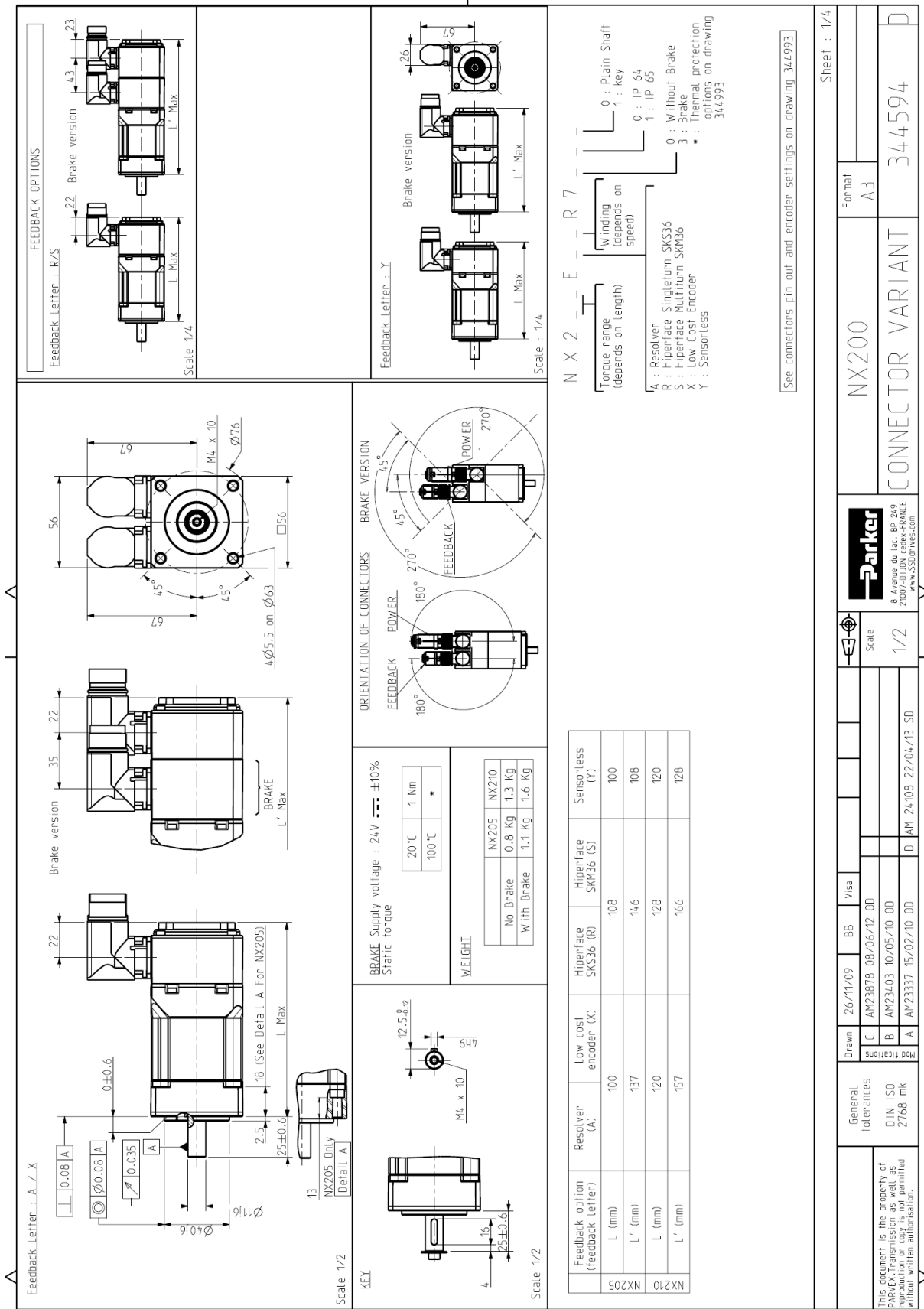

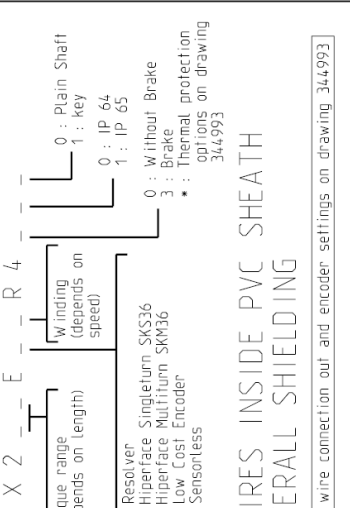
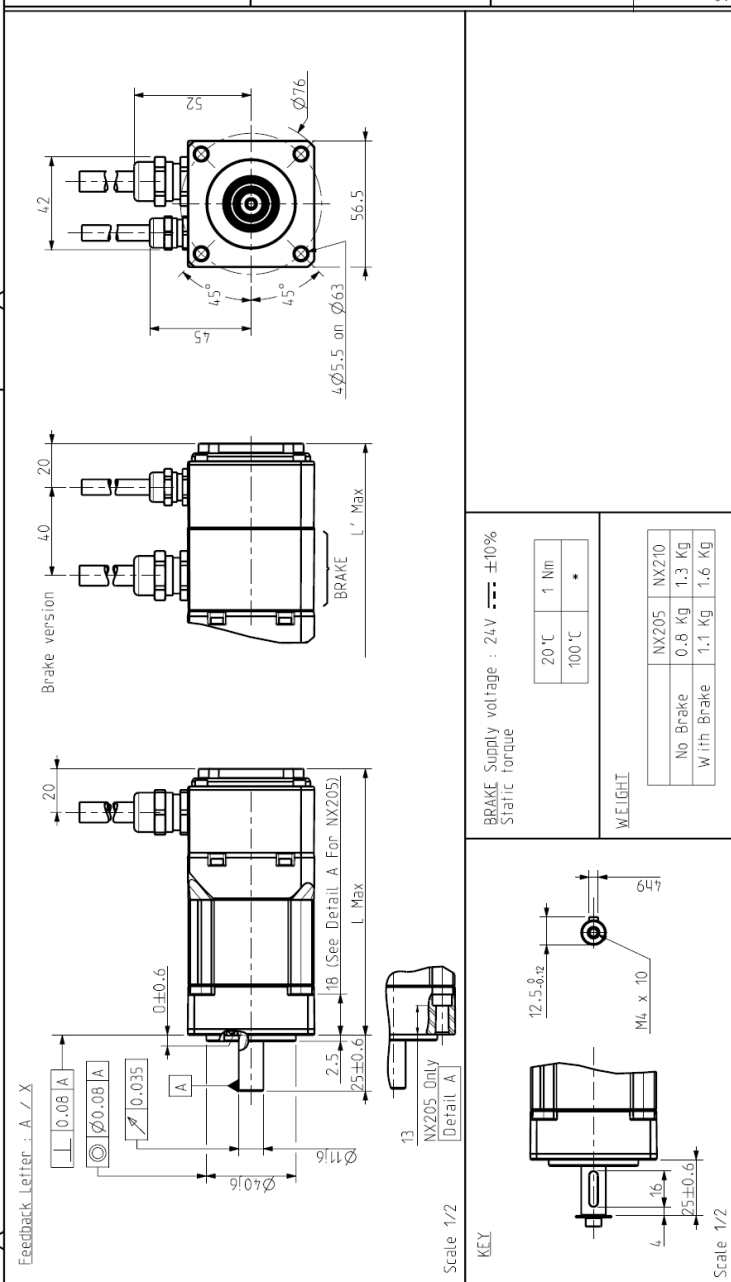
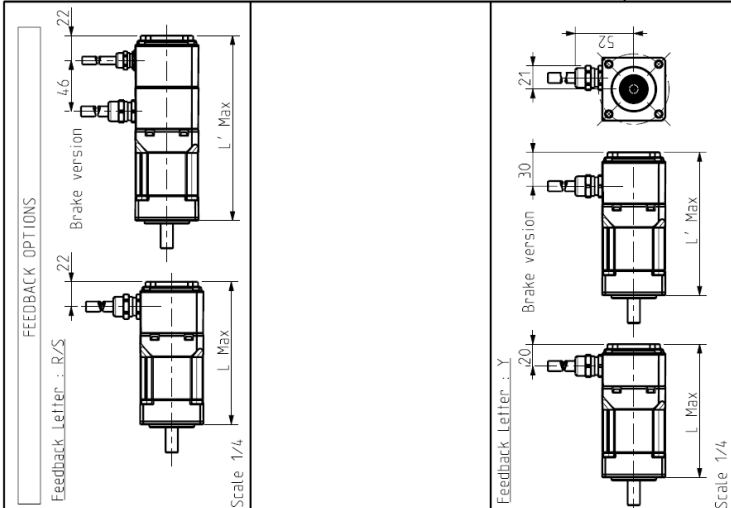

Feedback option (feedback letter)	Resolver (A)	Low cost encoder (X)	Hiperface SKS36 (R)	Hiperface SKM36 (S)	Sensorless (Y)
NX205	100	108	108	108	100
NX210	137	146	146	119	119
NX210	120	128	128	120	120
NX210	157	166	166	129	129

Sheet : 2/4

Parker
8 Avenue du Lac, BP 249
27007-DJON, CEDEX-FRANCE
www.ssd.drives.com

Scale 1/2

Format A3

NX200

WIRES INSIDE PVC SHEATH

344594

D

General tolerances
DIN ISO
2768 mik

Drawn 26/11/09 BB Visa
C AM23878 08/06/12 00
B AM23403 10/05/10 00
A AM23337 15/02/10 00

This document is the property of PARVEX-Transmission as well as reproduction or copy is not permitted without written authorisation.

Feedback Letter : Y

Scale 1/2

BRAKE Supply voltage : 24V ±10%

20 °C	1 Nm
100 °C	*

WEIGHT

NX205	NX210
No Brake	0.8 Kg
With Brake	1.1 Kg
	1.3 Kg
	1.6 Kg

Scale 1/2

N X 2 - E Y - R 6

- Torque range (depends on length)
- Winding (depends on speed)
 - 0 : Plain Shaft
 - 1 : Key
- 0 : IP 64
- 1 : IP 65
- 0 : Without Brake
- 3 : Brake
- * : Thermal protection options on drawing 344993

See connections pin out and encoder settings on drawing 344993

<p style="font-size: 8px;">8 Avenue du Lac - BP 249 21007-DJON cedex-FRANCE www.5SISpines.com</p>		Scale 1/2								
Drawn C AM23878 08/06/12 00 B AM23403 10/05/10 00 A AM23337 15/02/10 00	BB Visa	Sheet : 3/4								
General tolerances DIN ISO 2768 mk		Format A3								
This document is the property of PARKEX-Transmission as well as reproduction or copy is not permitted without written authorisation.		Sensorless (Y) <table border="1" style="width: 100%;"> <tr> <td>L (mm)</td> <td>100</td> </tr> <tr> <td>L' (mm)</td> <td>137</td> </tr> <tr> <td>L (mm)</td> <td>120</td> </tr> <tr> <td>L' (mm)</td> <td>157</td> </tr> </table>	L (mm)	100	L' (mm)	137	L (mm)	120	L' (mm)	157
L (mm)	100									
L' (mm)	137									
L (mm)	120									
L' (mm)	157									
NX200 SENSORLESS VARIANT		344594 D								

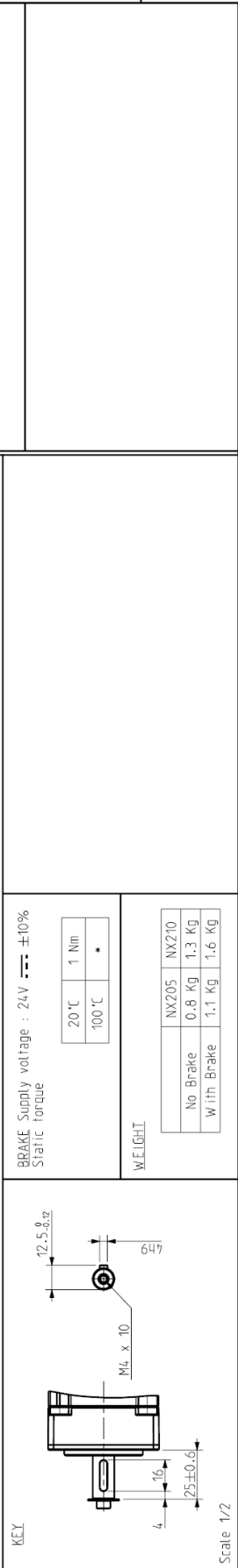
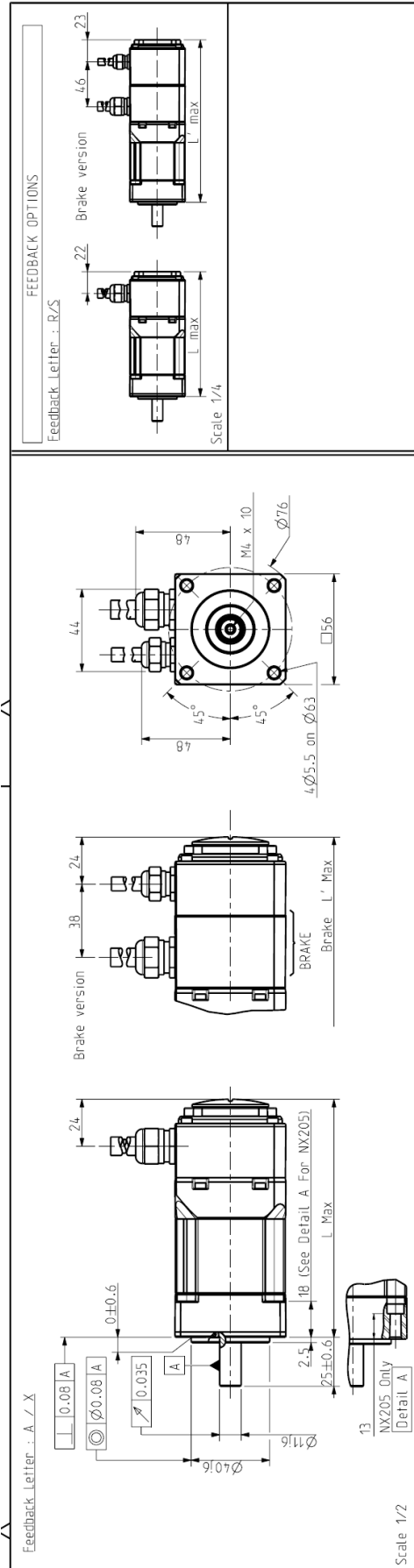

Feedback option (feedback letter)	Resolver (A)	Low cost encoder (X)	Hiperface SKS36 (R)	Hiperface SKM36 (S)
NX205	102	106	106	106
NX210	140	146	146	146
NX220	122	128	128	128
NX230	160	166	166	166

N X 2 — E — R 1

Torque range (depends on length)

Winding (depends on speed)

0 : Plain Shaft
1 : key

0 : IP 64
1 : IP 65

0 : Without Brake
3 : Brake

* : Thermal protection options on drawing 344993

A : Resolver
R : Hiperface Singleturn SKS36
S : Hiperface Multiturn SKM36
X : Low Cost Encoder
Y : Sensorless

See wire connection out and encoder settings on drawing 344993

Scale 1/2

Scale 1/2

Drawn 26/11/09 BB V/isa

General tolerances
DIN, ISO
Z768 mk

Modifications
C AM23878 08/06/12 00
B AM23403 10/05/10 00
A AM23337 15/02/10 00

Formal A3

344594

Sheet : 4/4

www.3Siprives.com

8 Avenue du lac - BP 249
21007-010N CEDEX-FRANCE

3.3.4. NX2 UL version

POWER CONNECTOR

FEEDBACK CONNECTOR

SHAFT END

ORIENTATION OF CONNECTORS

DIMENSIONS

NX205	NX210
L Maxi	129
B	78
	98

UL design
IP64
Drawing for motor :
R7000 (thermal sensor)
B7000 (paint black)
B7100 (paint black and thermal sensor)

General tolerances
DIN ISO 2768 mK

Weight :

Drawing valid for :

Scale
4:5

Format
A3

Formal
F x E x S x G x I

NX200A

OUTLINE DRAWING
344671AE7000 -

Parker
8, Avenue de la BP210
20007-DUMENEY-FRANCE
www.parker.com

POWER CONNECTOR F VIEW

FEEDBACK CONNECTOR F VIEW

1 : Phase U
2 : Ground
3 : Phase W
4 : Phase V
A : No connection
B : No connection
C, D : Temperature sensor (option)

Drawn 14/04/05 **BB** **Visa**

Modifications

POWER CONNECTOR

1 : Phase U
2 : Ground
3 : Phase W
4 : Phase V
A : Brake +
B : Brake -
C, D : No connection

FEEDBACK CONNECTOR

S4
S2
R2
R1
S3
S1

ORIENTATION OF CONNECTORS

FEEDBACK 270°
POWER 270°

SHAFT END

M4 x 10

DIMENSIONS

NX205	NX210
L Maxi 137	157
B 80	100

UL Design
IP 64

Drawing for motor :
B7300 (thermal sensor)
B7400 (thermal sensor)
B7300 (paint black)
B7400 (paint black and thermal sensor)

POWER CONNECTOR

BRAKE
Supply voltage : 24V ±10%
Static torque

100°	temp	Torque
20°	1 Nm	

General tolerances
DIN ISO 2768 mK

Weight :

Drawing valid for :

Drawn 12/04/05 BB Visa

General tolerances
DIN ISO 2768 mK

Format A3
F x E x S x G x I
x x x x x

OUTLINE DRAWING 344671AE7300

Parker
8 Avenue du Lac BP269
21007-01000 CEDEX-FRANCE
www.parker.com

Scale 4:5

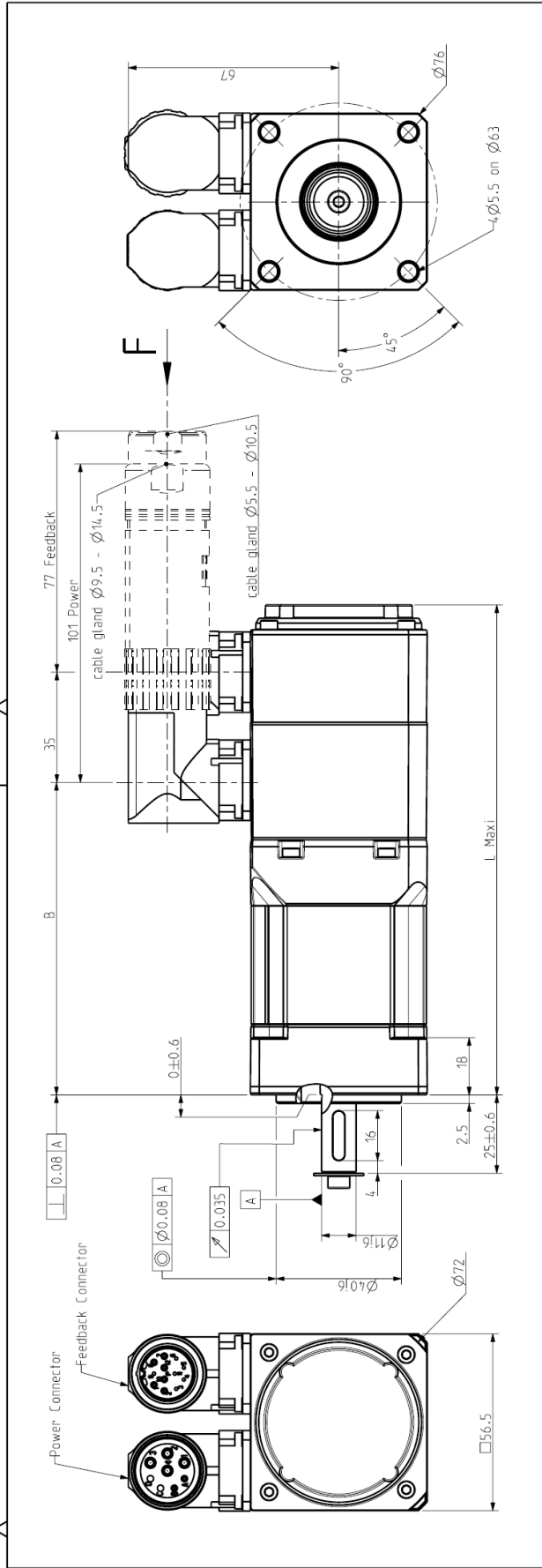

POWER CONNECTOR

FEEDBACK CONNECTOR

F VIEW

1 : Phase U
2 : Ground
3 : Phase W
4 : Phase V
A : Brake +
B : Brake -
C, D : No connection

BRAKE

Supply voltage : 24V
Static torque : ±10%

100%	temp Torque
20°	1 Nm

ORIENTATION OF CONNECTORS

SHAFT END

DIMENSIONS

NX205	NX210
L Maxi	137
B	80
	100

UL Design
IP 64
Drawing for motor :
R7300 (thermal sensor)
B7300 (paint black)
B7400 (paint black and thermal sensor)

Drawing valid for :

Weight :

General tolerances
DIN ISO 2768 mK

This document is the property of PARKEX. Transmission as well as reproduction is strictly prohibited without written authorization.

Drawn 20/02/13 AH Visa

Format A3

NX200A

Scale 4:5

OUTLINE DRAWING

344671AE7301

3.3.5. NX3

FEEDBACK OPTIONS

Feedback letter: R/S/V/W. Scale 1:5. Brake Version.

Feedback letter: T/U. Scale 1:5.

Feedback letter: X. Scale 1:5.

ORIENTATION OF CONNECTORS

270° SIGNAL

270° POWER

Feedback letter: A/X. Scale 1:2.

94, 38, 0±0.6, 2.5, 8.5, 23±0.6, L' Max.

86, Brake Version, L' Max.

54, 75, 45°, 45°, 4 X Ø5.5 on Ø75 to Ø80, Ø71, M4 x 10, Ø94.

BRAKE

BRAKE Supply voltage : 24V ±10%

Static torque	20°C	2 Nm
	100°C	1.8 Nm

WEIGHT

No Brake	NX310	2 Kg
With Brake		2.4 Kg

Feedback letter: A/X. Scale 1:2.

94, 38, 0±0.6, 2.5, 8.5, 23±0.6, L' Max.

86, Brake Version, L' Max.

54, 75, 45°, 45°, 4 X Ø5.5 on Ø75 to Ø80, Ø71, M4 x 10, Ø94.

SHAFT END

12.5^{+0.02}, 4.5, M4 x 10, 3.5, 7.6, 23±0.6, Scale 1:2.

Feedback options table:

Feedback options (feedback letter)	Resolver (A)	Low cost encoder (X)	Hiperface SKS36 (S)	Hiperface SKR36 (R)	Hiperface SKS36 (R)	Hiperface SRS50 (T)	Hiperface SRM50 (U)	Sensorless (Y)
L (mm)	147	182	176	173	147	195		
L' (mm)	195	230	224	221				

NX310 E R 7

Torque range (depends on length)

Winding (depends on speed)

0 : Plain Shaft
1 : key
0 : IP 64
1 : IP 65

0 : Without Brake
3 : Brake
* : Thermal protection options on drawing 344993

A : Resolver Singleturn SKS36
R : Hiperface Multiturn SKM36
S : Hiperface Singleturn SRS50
T : Hiperface Singleturn SRM50
U : Hiperface Multiturn SRM50
V : Endat Singleturn ECN113
W : Endat Multiturn EQN125
X : Low Cost Encoder
Y : Sensorless

See connectors pin out and encoder settings on drawing 344993

Drawn: 03/07/09 YG Visa

C AM 24/08 22/04/13 SD

B AM23/03 10/05/10 DD

A AM23/37 15/02/10 DD

General tolerances: DIN ISO 2768 mK

Scale: 1:2

Sheet: 1/3

Format: A3

CONNECTOR VARIANT: 344167

This document is the property of PARKER. Transmission as well as reproduction or copy is not permitted without written authorisation.

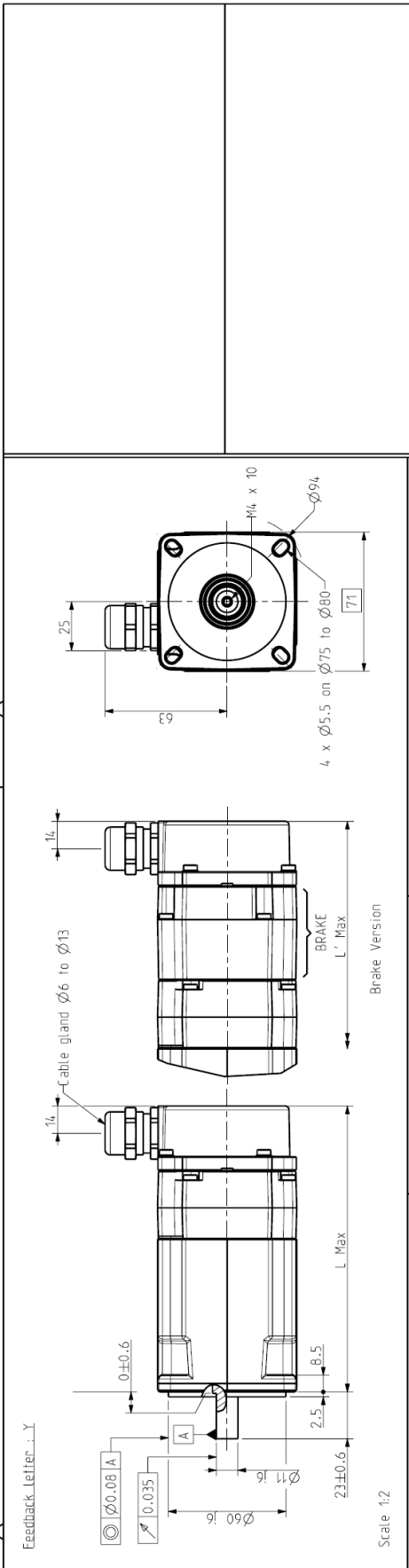

Feedback Letter: . Y

Scale 1:2

Key

Shaft End

BRAKE Supply voltage : 24V ±10%
Static torque

20 °C	2 Nm
100 °C	1.8 Nm

Weight

No Brake	NX310	2 Kg
With Brake		2.4 Kg

Scale 1:2

N X 3 1 0 E Y - R 6

Torque range (depends on length)

Winding (depends on speed)

0 : Plain Shaft
1 : Key
0 : IP 64
1 : IP 65

0 : Without Brake
3 : Brake
• : Thermal protection options on drawing 344993

Feedback option (feedback letter)

Sensorless (Y)

L (mm) 147

L' (mm) 195

[See connections pin out and encoder settings on drawing 344993]

Parker		8 Avenue du lac BP249 21007-DJON LEBREY-FRANCE www.ssd-drives.com	
Drawn	03/07/09	YG	V/isa
Revision	C AM 24-108 22/04/13 SD		
	B AM23403 10/05/10 00		
	A AM23337 15/02/10 00		
General tolerances	DIN ISO 2768 mK		
This document is the property of PARKEX-Transmission as well as reproduction or copy is not permitted without written authorization.			
Format	NX300		Sheet : 2/3
Format	A3		F E S G I
SENSORLESS VARIANT			X
			344167

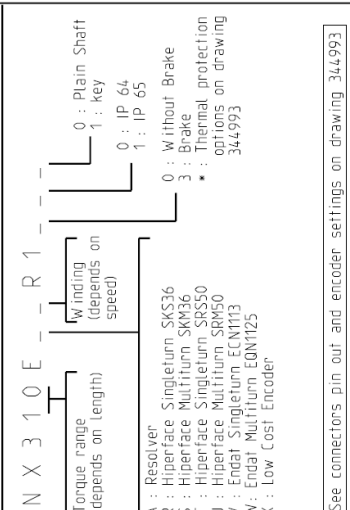
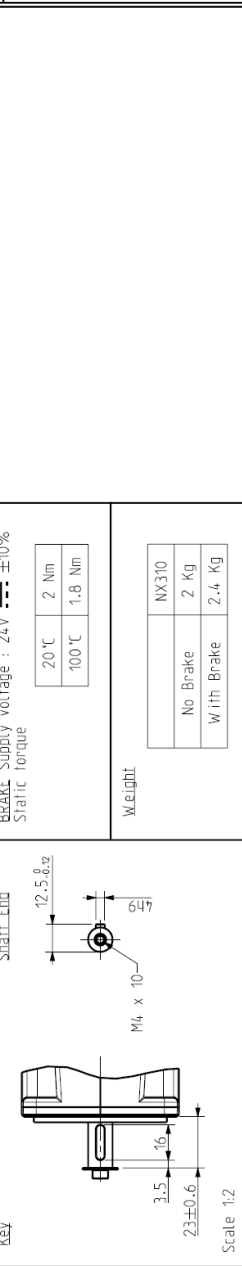
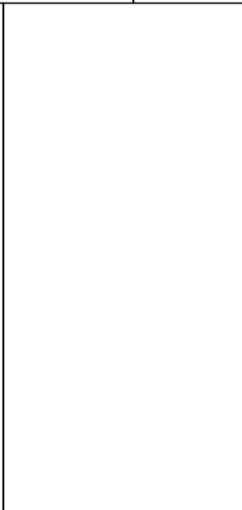
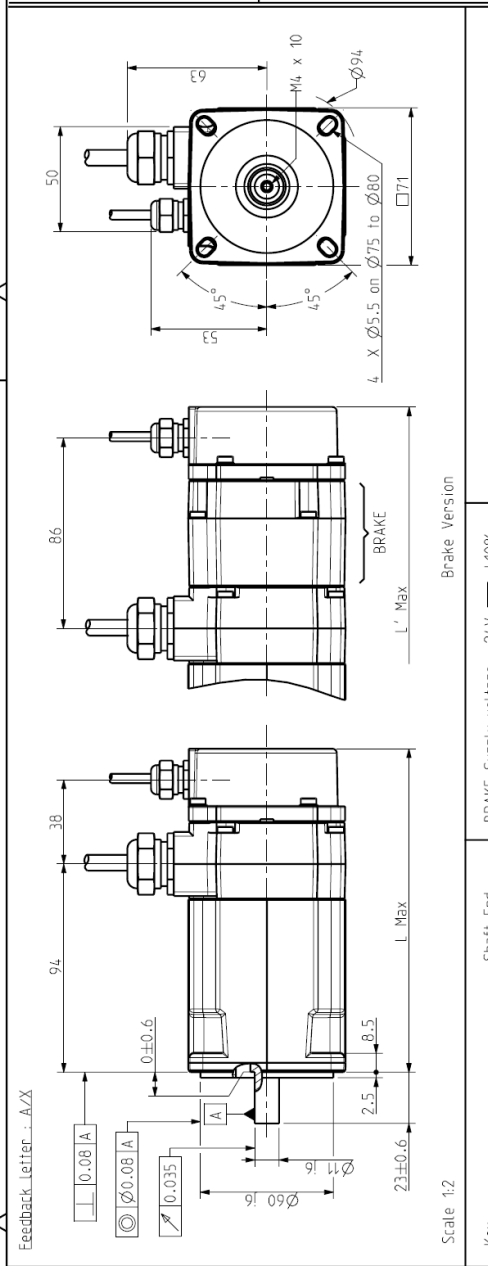
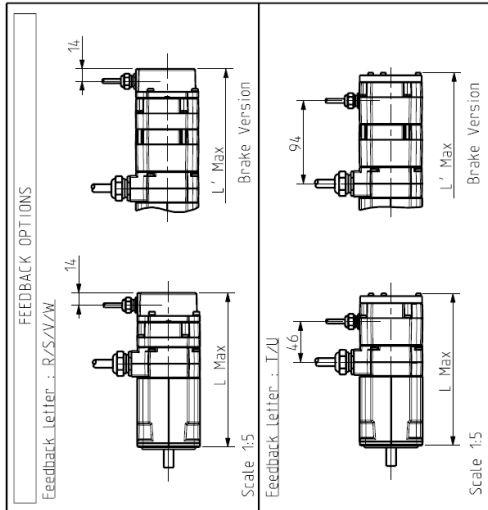

Feedback options (feedback letter)	Resolver (A)	Low cost encoder (X)	Hiperface SKS36 (R)	Hiperface SKM36 (S)	Endat ECM113 (V)	Endat EGM125 (W)	Hiperface SRS50 (T)	Hiperface SRM50 (U)
L (mm)	147		182		176		173	
L' (mm)	195		230		224		221	

See connectors pin out and encoder settings on drawing 344993

Sheet : 3/3

Format A3

NX300

CABLE VARIANT

344167

Scale 1:2

General tolerances DIN ISO 2768 mK

Drawn: 03/07/09 YG W/isa

CAM 24/108 22/04/13 SD

B AM23403 10/05/10 DD

A AM23337 15/02/10 DD

This document is the property of PARVEX. Transmission as well as reproduction or copy is not permitted without written authorisation.

8 Avenue du lac - BP249
21007-DIJON LEVEX-FRANCE
www.ssdiprives.com

3.3.6. NX4

Feedback letter: A/X

Scale 2:5

Feedback letter: R/S/V/X/Z

Scale 1:5

Feedback letter: T/U

Scale 1:5

Feedback letter: Y

Scale 1:5

FEEDBACK OPTIONS

N X 4 - E - R 7

Torque range (depends on length)

Winding (depends on speed)

0 : Plain Shaft
1 : key

0 : without Brake
3 : Brake

A : Resolver
R : Hiperface Singleturn SKS36
S : Hiperface Multiturn SKM36
T : Hiperface Singleturn SRM50
U : Hiperface Multiturn SRM50
V : Endat Singleturn ECN113
W : Endat Multiturn EQN125
X : Low Cost Encoder
Y : Sensorless

See connectors pin out and encoder settings on drawing 344993

ORIENTATION OF CONNECTORS

270°

SIGNAL

POWER

BRAKE Supply voltage : 24V ±10%

Static torque

NX420	NX430
20 °C	6 Nm
100 °C	5 Nm

Weight

No Brake	NX420	NX430
with Brake	3.7 Kg	4.6 Kg
	4.5 Kg	5.4 Kg

SHAFT END

Scale 2:5

Feedback options (feedback letter)	Resolver (A)	Low cost encoder (X)	Hiperface SKS36 (R)	Hiperface SKM36 (S)	Endat ECN113 (V)	Endat EQN125 (W)	Hiperface SKS50 (T)	Hiperface SRM50 (U)	Sensorless (Y)
NX420	175		206	261	231	286	205	226	175
NX430	226		261	231	286	281	256	200	226
	251		286	231	286	281	230	200	251

CONNECTOR VARIANT

See connectors pin out and encoder settings on drawing 344993

Drawn: 03/07/09

Drawn: C AM 24/108 22/04/13 SD

Drawn: B AM23403 10/05/10 00

Drawn: A AM23337 15/02/10 00

Scale: 2:5

General tolerances: DIN ISO 2768 mK

Parker

8 Avenue du lac BR209
21007-DJON CEDEX-FRANCE
www.ssdinstruments.com

Sheet: 1/4

Format: A3

344178

This document is the property of PARKEX-Transmission as well as reproduction or copy is not permitted without written authorisation.

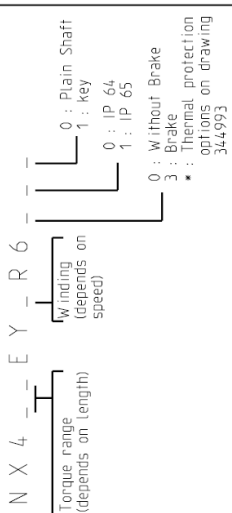
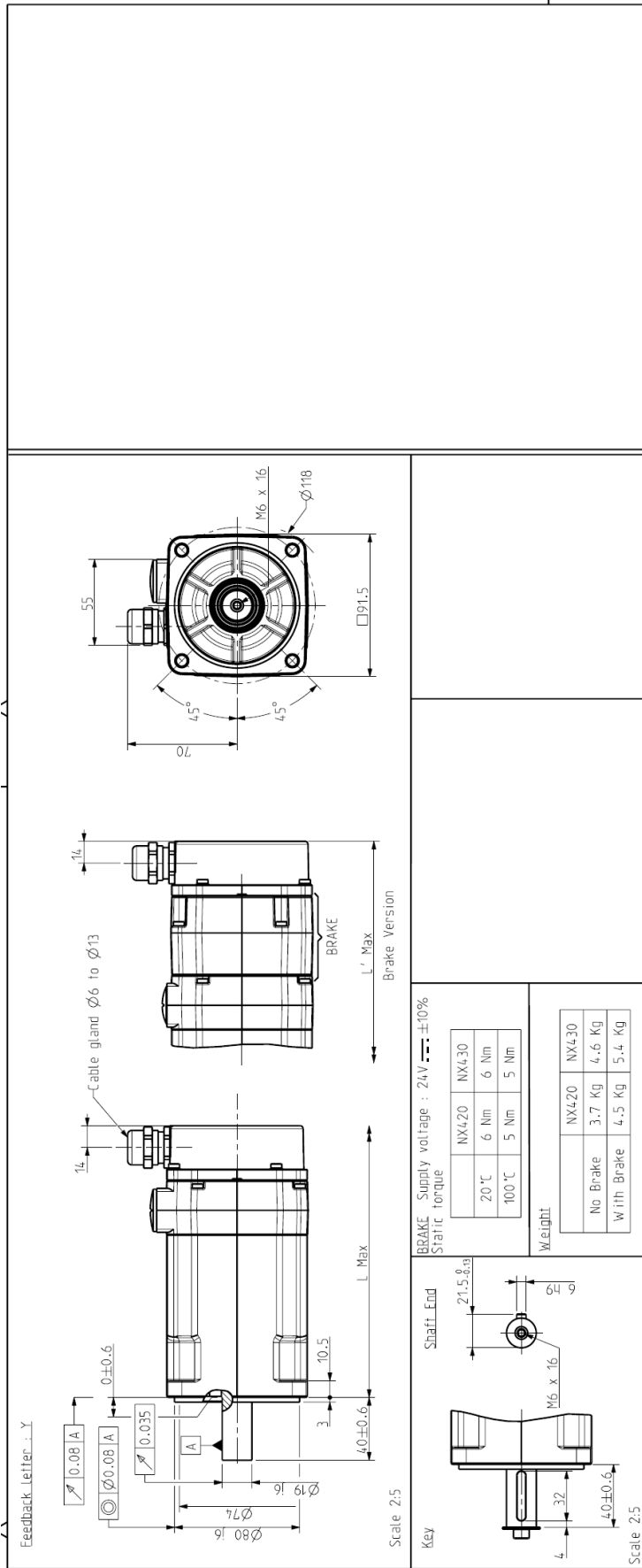

See connectors pin out and encoder settings on drawing 344993

<p>8 Avenue du lac - BP219 27080 LES MOULINS www.SSDPIVES.COM</p>		Scale 2.5		Drawn 03/07/09		00		Visa		Sheet : 2/4	
NX400		Format A3		F		E		S		G	
SENSORLESS VARIANT		344178		C		A		B		AM	
General tolerances DIN ISO 2768 mK		AM23403 10/05/10 00		AM23337 15/02/10 00		22/04/13 SD		10/05/10 00		15/02/10 00	
This document is the property of reproduction or copy is not permitted without written authorisation.											

Feedback Letter: AX

Scale 2:5

ORIENTATION OF CONNECTOR

POWER TERMINAL BOX ORIENTATION

Standard orientation: BR

BRAKE Supply voltage : 24V --- ±10%

Static torque	NX420	NX430
20 °C	6 Nm	6 Nm
100 °C	5 Nm	5 Nm

Weight

	NX420	NX430
No Brake	3.7 Kg	4.6 Kg
With Brake	4.5 Kg	5.4 Kg

Shaft End

Scale 2:5

Feedback options (feedback letter)	Resolver (A)	Low cost encoder (X)
L (mm)	175	
L' (mm)	226	
L (mm)	200	
L' (mm)	251	

N X 4 E R 6

Torque range (depends on length)

Winding (depends on speed)

0 : Plain Shaft
1 : key
0 : IP 64
1 : IP 65

0 : W/without Brake
3 : Brake
* : Thermal protection options on drawing 344993

X : Low Cost Encoder

See connectors pin out and encoder settings on drawing 344993

Drawn 03/07/09 00 Visa

C AM 24108 22/04/13 SD

B AM23403 10/05/10 00

A AM23337 15/02/10 00

General tolerances
DIN ISO 2768 mK

Scale 2:5

Sheet : 3/4

Format A3

Format F E S G I

344178

TERMIANL BOX VARIANT

8 Avenue du Lac - 89240
28000 St. Pierre - France
www.SSDPines.com

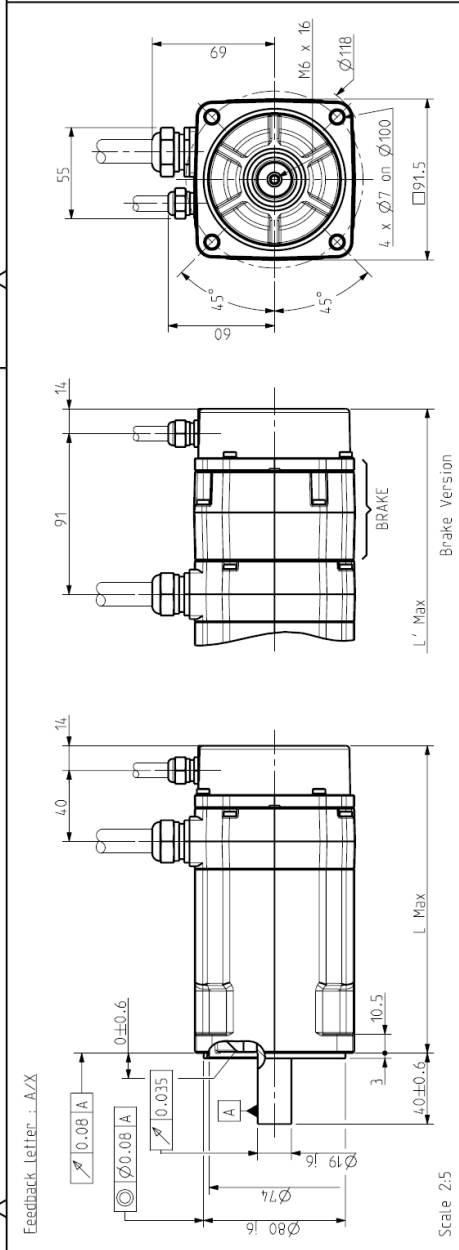
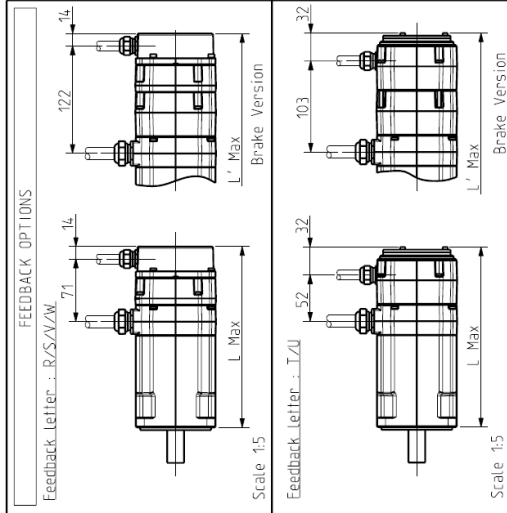

BRAKE Supply voltage : 24V ±10%

Static torque

	NX420	NX430
20°C	6 Nm	6 Nm
100°C	5 Nm	5 Nm

Weight

No Brake	3.7 Kg	4.6 Kg
With Brake	4.5 Kg	5.4 Kg

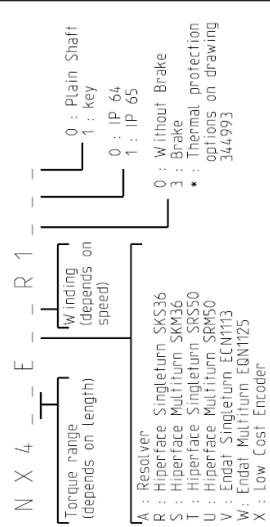
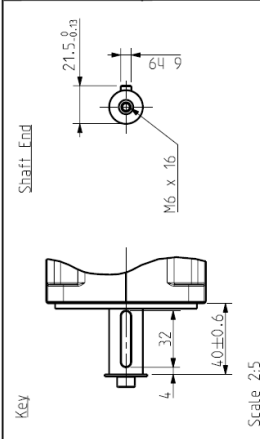

Feedback options (feedback letter)	Resolver (A)	Low cost encoder (X)	Hiperface SKS36 (R)	Hiperface SKM36 (S)	Endat EGM113 (V)	Endat EGM125 (W)	Hiperface SR550 (T)	Hiperface SRM50 (U)
NX420	175		206				205	
NX430	226		261				256	
	200		231				230	
	251		286				281	

See connectors pin out and encoder settings on drawing 344993

General tolerances
DIN ISO 2768 mK

Drawn: 03/07/09
C AM 24108 22/04/13 SD

Modifications
B AM23403 10/05/10 0D
A AM23337 15/02/10 0D

Scale 2.5

Format A3

NX400

CABLE VARIANT

344178

Sheet : 4/4

F E S G I
x

8 Avenue du lac, BP249
2007-DJON cedex-FRANCE
www.SSDrives.com

This document is the property of PARVEX. Transmission as well as reproduction or copy is not permitted without written authorisation.

3.3.7. NX6

Feedback Letter: A/Z

Scale 3:10

SHAFT END

KEY

BRAKE Supply voltage : 24V ±10%
Static torque

	NX620	NX630
20°C	12 Nm	12 Nm
100°C	10 Nm	10 Nm

WEIGHT

	NX620	NX630
No brake	6.9 Kg	8.8 Kg
With brake	8 Kg	10 Kg

Scale 3:10

FEEDBACK OPTIONS

Feedback letter: B/S/A/W.

Scale 1:5

Feedback letter: T/U

Scale 1:5

Feedback letter: Y

Scale 1:5

ORIENTATION OF CONNECTORS

CONNECTOR VARIANT

Feedback options (feedback letter)	Resolver (A)	Low Cost Encoder (X)	Hiperface SKS36 (R)	Hiperface SKP36 (S)	Endat EC.M113 (V)	Endat EQM125 (W)	Hiperface SRS50 (T)	Hiperface SRM50 (U)	Sensorless (Y)
L (mm)	181			216			214		181
L' (mm)	236			271			269		236
L (mm)	210			245			243		210
L' (mm)	265			300			298		265

N X 6 - E - R 7

Torque range (depends on length)

Winding (depends on speed)

0 : Plain Shaft
1 : Key

0 : Without Brake
3 : Brake

* : Thermal protection options on drawing 344.993

A : Resolver Singleturn SKS36
S : Hiperface Multiturn SKM36
U : Hiperface Multiturn SRM50
L : Hiperface Multiturn SRS50
V : Endat Singleturn EC.M113
W : Endat Multiturn EQM125
X : Low Cost Encoder
Y : Sensorless

See connections pin out and encoder settings on drawing 344.993

sheet : 1/3

Format A3

344189

Parker
8 Avenue du lac BP249
21007-DIJON cedex-FRANCE
www.SSDrives.com

Scale 3:10

Drawn 09/07/09 PR Visa

General tolerances
DIN ISO 2768 mK

Modifications
B AM 24.08 22.02.13 SD
A AM23337 15.02.10 00

Feedback letter : Y

Scale 3:10

BRAKE Supply voltage : 24V ±10%

Static torque

	NX620	NX630
20°C	12 Nm	12 Nm
100°C	10 Nm	10 Nm

WEIGHT

	NX620	NX630
No brake	6.9 Kg	8.8 Kg
With brake	8 Kg	10 Kg

Scale 3:10

N X 6 - E Y - R 6

- Torque range (depends on length)
- Winding (depends on speed)
 - 0 : Plain Shaft
 - 1 : Key
- 0 : IP 64
- 1 : IP 65
- 0 : Without Brake

* : Thermal protection options on drawing 344993

See connectors pin out and encoder settings on drawing 344993

Format	A3	Sheet	2/3
NX600		SENSORLESS VARIANT	
344189			

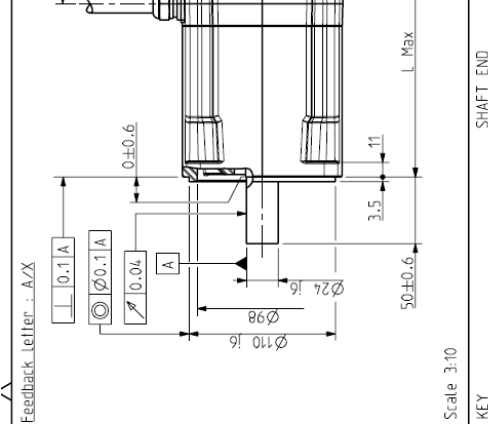
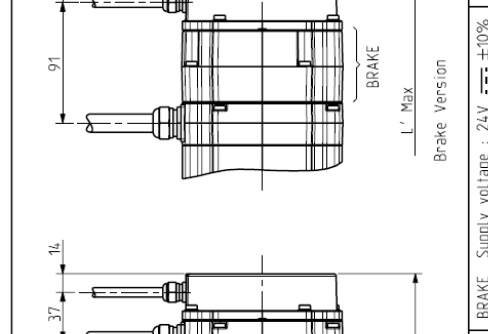
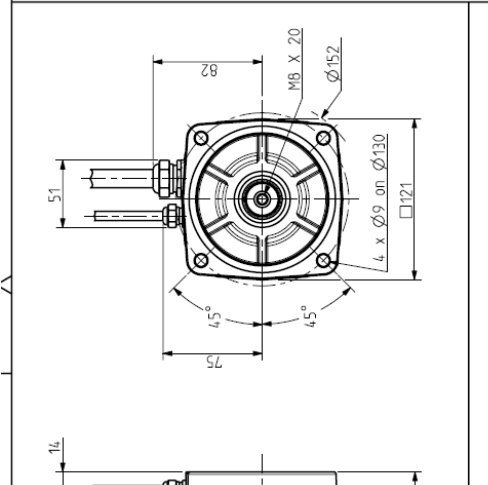
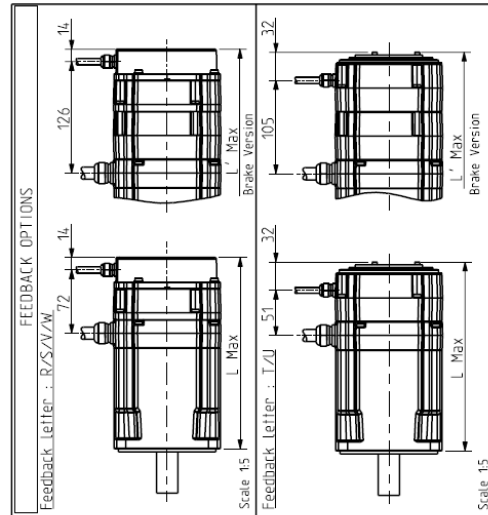

BRAKE Supply voltage : 24V ±10%
Static torque

	NX620	NX630
20°C	12 Nm	12 Nm
100°C	10 Nm	10 Nm

WEIGHT

	NX620	NX630
No brake	6.9 Kg	8.8 Kg
With brake	8 Kg	10 Kg

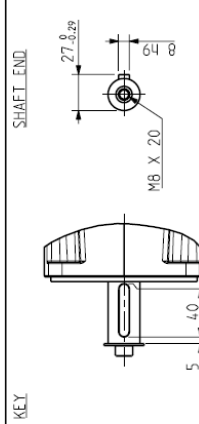

Feedback options (feedback letter)	Resolver (A)	Low Cost Encoder (X)	Hiperface SKS36 (R)	Hiperface SKM36 (S)	Endat ECN113 (V)	Endat EQN1125 (W)	Hiperface SRS50 (T)	Hiperface SRM50 (U)	Sensorless (Y)
NX620	181	216	271	245	300	214	269	210	181
NX630	236	271	245	300	298	269	243	265	236

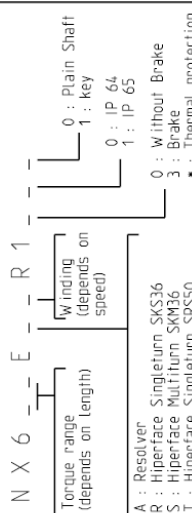

See connectors pin out and encoder settings on drawing 344993.

09/07/09 PR

General tolerances
DIN ISO 2768 mK

Modifications
B AM 24.108 22/04/13 SD
A AM23337 15/02/10 DD

3:10

3:10

Format A3

sheet : 3/3

CABLE VARIANT

344189

B

This document is the property of PARKEX. Transmission as well as reproduction or copy is not permitted without written authorisation.

8, Avenue du Lac - BP249
21007-DJON cedex-FRANCE
www.SS09rives.com

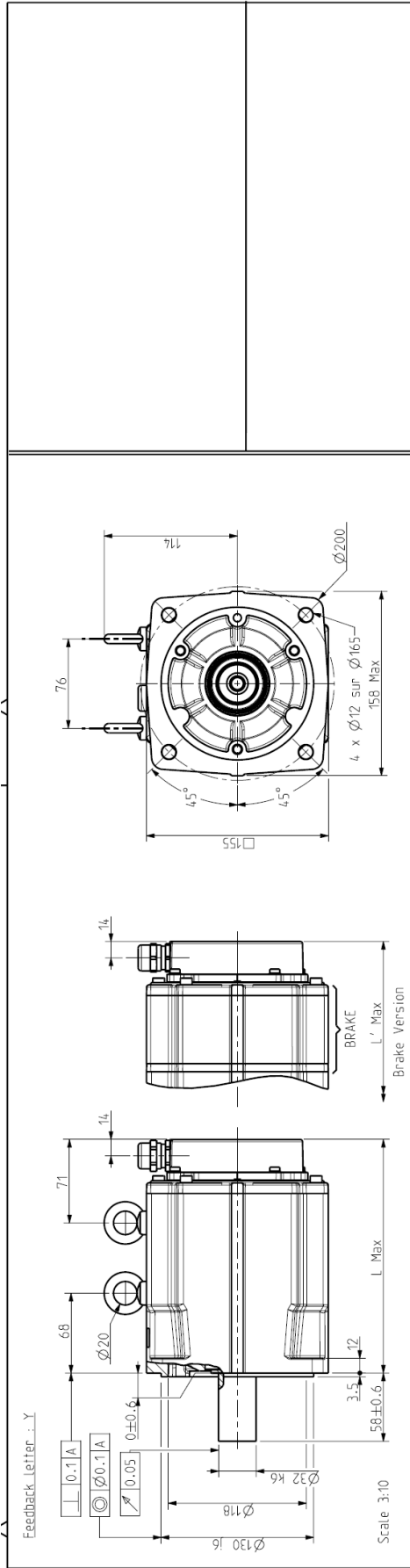

Feedback letter : Y

BRAKE Supply voltage : 24V Static torque : ±10%

	NX820	NX840	NX860
20 °C	36 Nm	36 Nm	36 Nm
100 °C	32 Nm	32 Nm	32 Nm

Weight

	NX820	NX840	NX860
No Brake	13 Kg	20 Kg	27 Kg
With Brake	16.5 Kg	23.5 Kg	30.5 Kg

Shaft End

Key

Scale 3:10

N X 8 - E Y - R 6

Torque range (depends on length)

Winding (depends on speed)

0 : Plain Shaft
1 : Key
0 : IP 64
1 : IP 65

0 : Without Brake
3 : Brake
• : Thermal protection options on drawing 344993

[See connectors pin out and encoder settings on drawing 344993]

Drawn	09/07/09	YG	Viso
C	AM24108	22/04/13	SD
B	AM24031	14/12/12	BB
A	AM23337	15/02/10	00

General tolerances
DIN ISO 2768 mK

This document is the property of PARKEX. Transmission as well as reproduction or copy is not permitted without written authorisation.

Scale 3:10

Parker
B Avenue du Lac BP249
21007-DJON cedex-FRANCE
www.SSDrives.com

NX800

SENSORLESS VARIANT

344469

Sheet:2/4

Format A3

F E S G I

3.3.9. NX8 water cooled

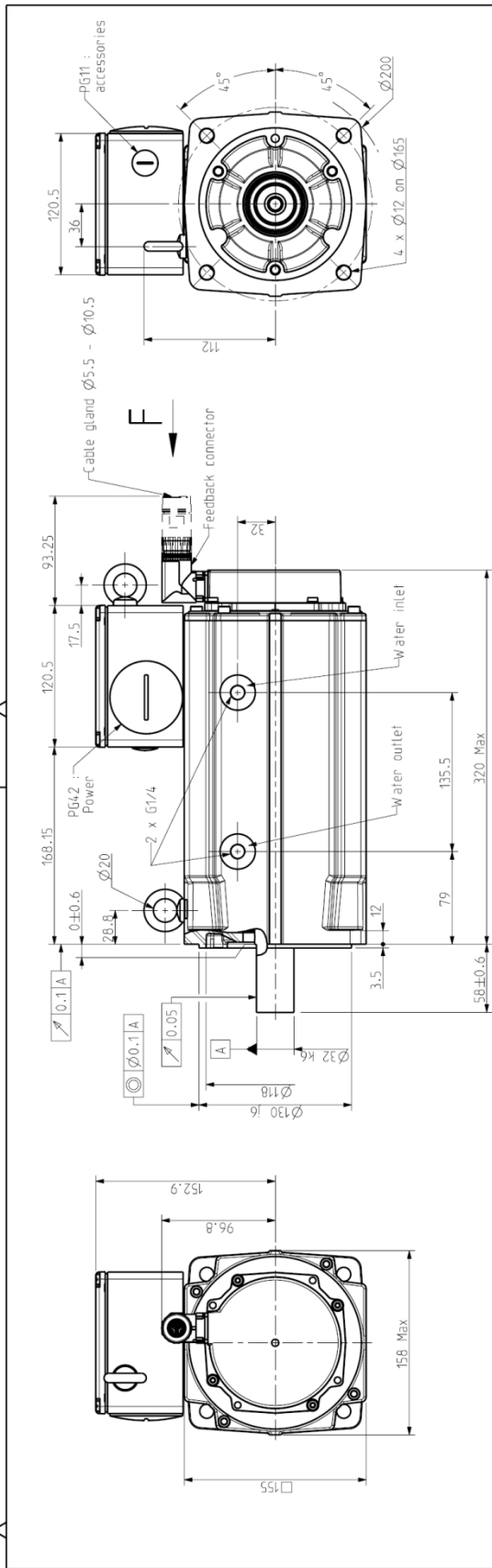

<p>TERMINAL BOX</p> <p>W 3 W8 terminals V U</p> <p>4 M4 terminals 1 2 3 4</p> <p>U : Phase U V : Phase V W : Phase W 1 : No connection 2 : No connection 3 : Thermal sensor (option) 4 : Thermal sensor (option)</p>		<p>GROUND IN THE TERMINAL BOX (W8)</p> <p>ABSOLUTE ENCODER</p> <p>red : Us blue : GND brown : Ref sin black : Ref cos grey : Data + green : Data - white : sin + pink : cos +</p> <p>Hiperface interface 1024 CPR Amplitude of analogue signals 1V_{cc} Supply voltage : 4.8V Working temperature : 115 °C</p>		<p>ORIENTATION OF CONNECTOR</p> <p>SIGNAL 180°</p>		<p>SHAFT END</p> <p>M12 x 28</p>	
<p>FEEDBACK CONNECTOR</p> <p>F view</p> <p>sin + Ref sin cos + Ref cos GND US</p> <p>Data + Data -</p> <p>Encoder setting :</p> <p>Motor powered by direct current at the current nominal value (W+ and V-). The shift is 90° electrical.</p>		<p>Drawing valid for : -</p>		<p>Format A3</p> <p>NX860W</p> <p>SSD Parvex 8 Avenue du Lac - 72420 20071 - FRANCE www.SSDparvex.com</p>			
<p>Weight :</p> <p>This document is the property of the company. Its reproduction or reproduction or copy is not permitted without written authorisation.</p>		<p>General tolerances DIN ISO 2768 mK</p>		<p>Scale 3:10</p> <p>OUTLINE DRAWING</p> <p>345070AE6000 -</p>			

3.4. Motor Mounting

3.4.1. Motor mounting

By flange in any direction

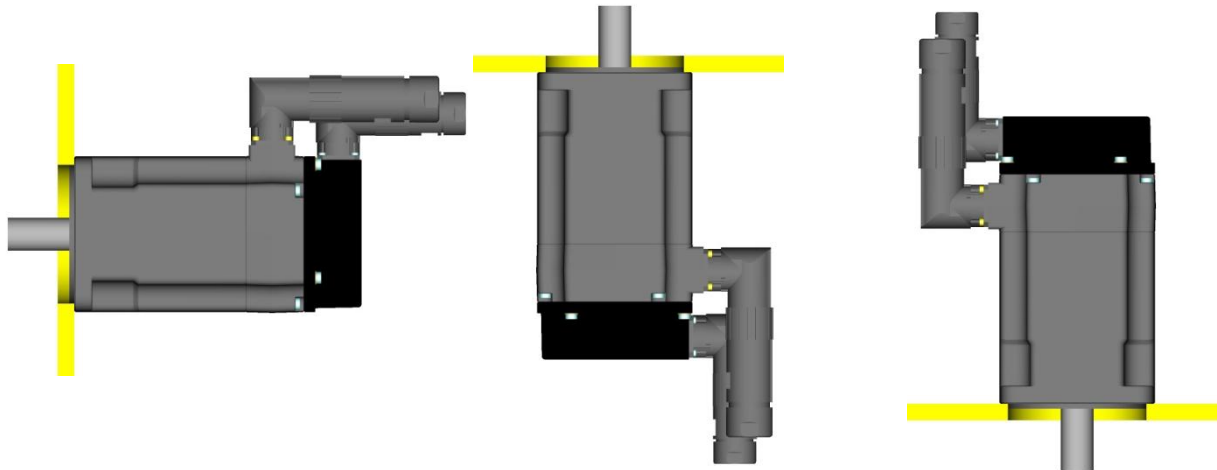

	<p>Warning : For NX8 with fan cooling, the air inlet of the fan has to be at 100mm mini from a wall.</p>

3.4.2. Frame recommendation



Warning : The user has the entire responsibility to design and prepare the support, the coupling device, shaft line alignment, and shaft line balancing.

Foundation must be even, sufficiently rigid and shall be dimensioned in order to avoid vibrations due to resonances.

The servomotors need a rigid support, machined and of good quality.

The maximum flatness of the support has to be lower than 0.05mm.

The motor vibration magnitudes in rms value are in accordance with IEC 60034-14 – grade A:

- maximum rms vibration velocity for NX is 1.3mm/s for rigid mounting



Warning : A grade A motor (according to IEC 60034-14) well-balanced, may exhibit large vibrations when installed in-situ arising from various causes, such as unsuitable foundations, reaction of the driven motor, current ripple from the power supply, etc.

Vibration may also be caused by driving elements with a natural oscillation frequency very close to the excitation due to the small residual unbalance of the rotating masses of the motor.

In such cases, checks should be carried out not only on the machine, but also on each element of the installation. (See ISO 10816-3).

3.5. Shaft Loads

3.5.1. Vibration resistance to shaft end

Frequency domain :10 to 55 Hz according to EN 60068 -2-6

Vibration resistance to the shaft end :

- radial 3 g
- axial 1 g

3.5.2. Motors life time for horizontal mounting



Notice: Curves below are valid only for horizontal mounting and a life time L10 of 20 000h at constant speed in accordance with ISO281.

Notice: Radial and Axial Loads are not additive

3.5.2.1. NX110

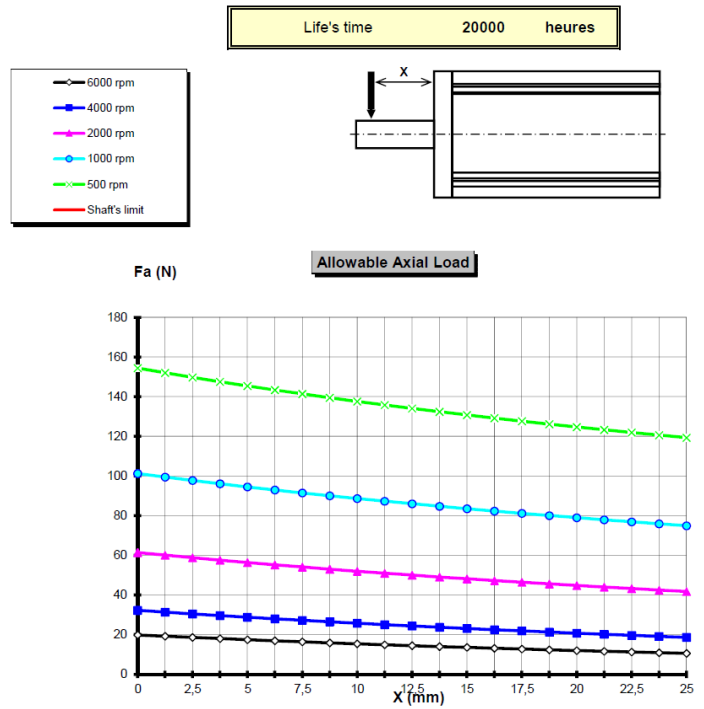
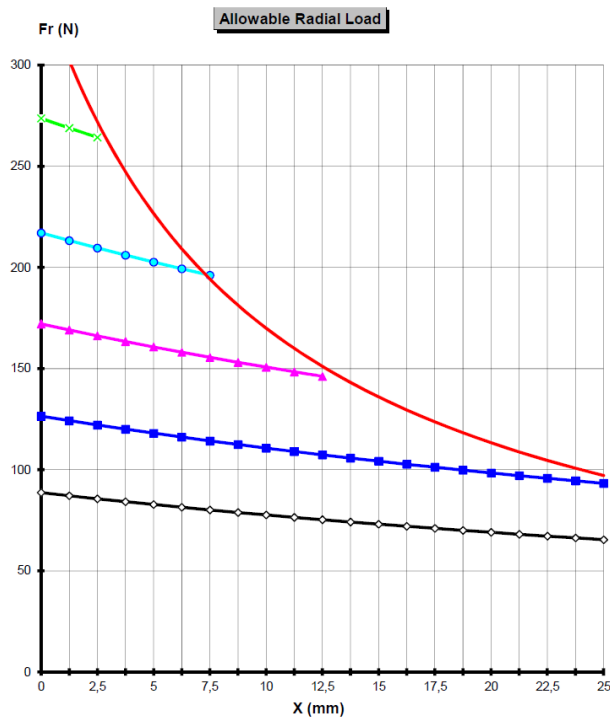

3.5.2.2. NX205

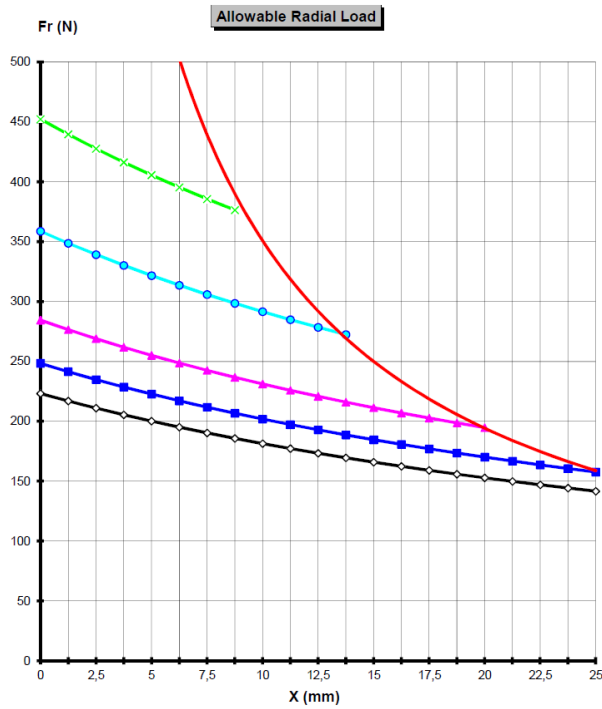

Life's time 20000 heures

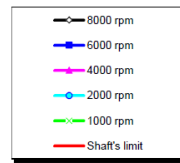
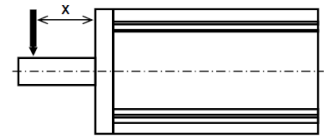

Allowable Axial Load

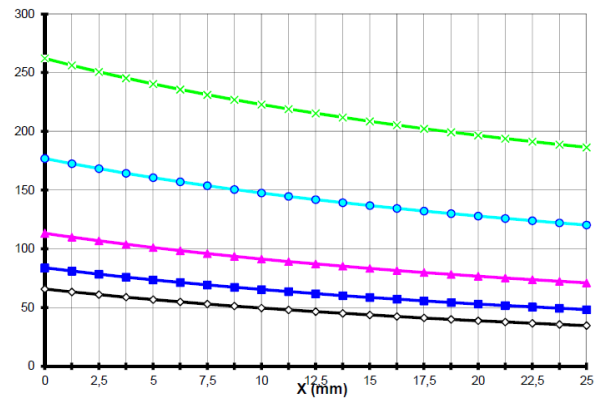

3.5.2.3. NX210

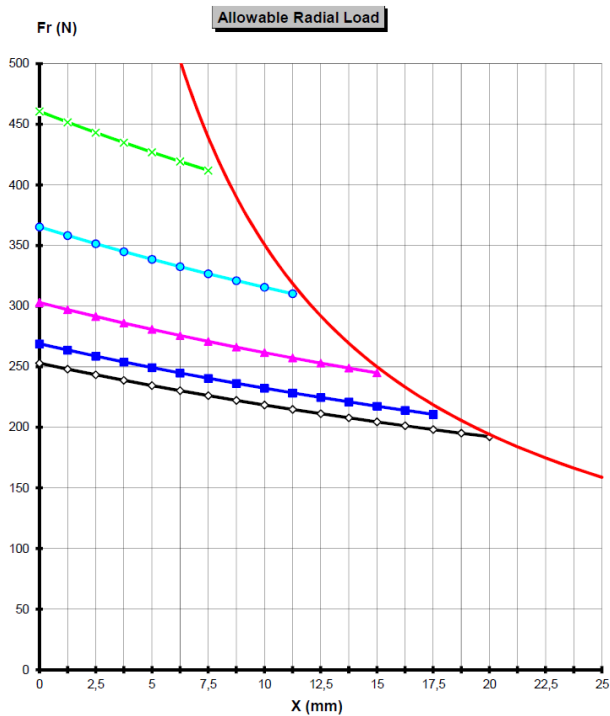

Life's time 20000 heures

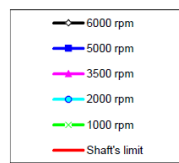
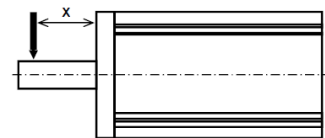

Allowable Axial Load

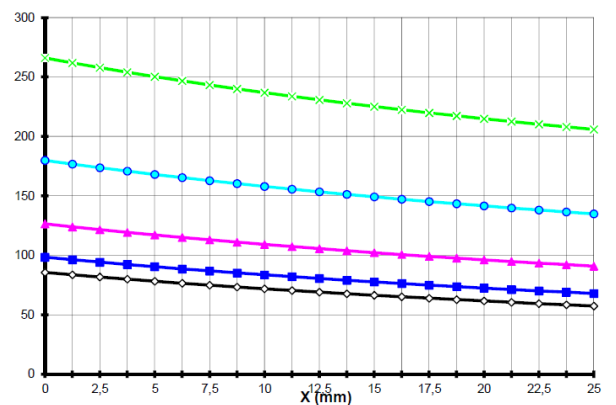

3.5.2.4. NX310

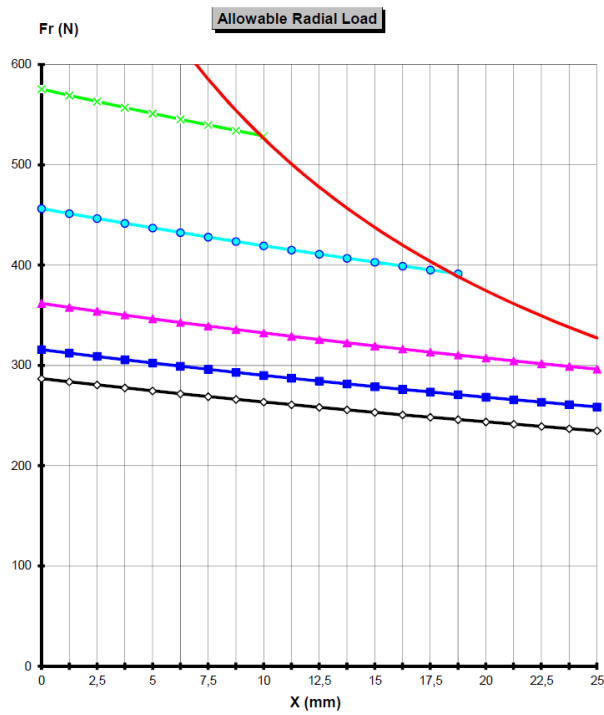

Life's time 20000 heures

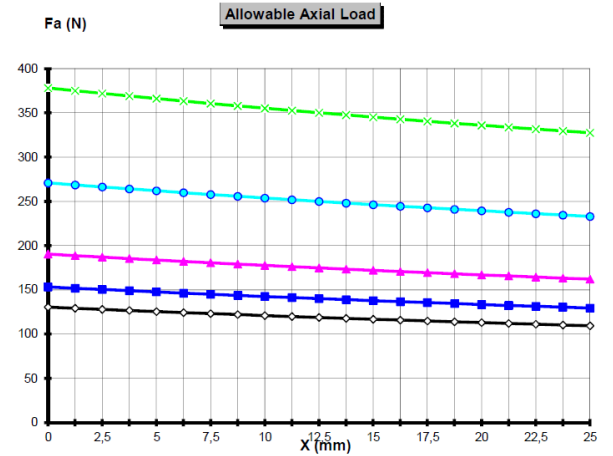
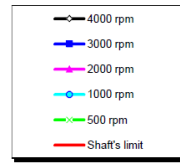
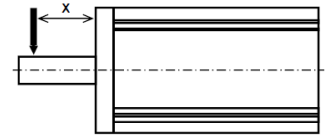

3.5.2.5. NX420

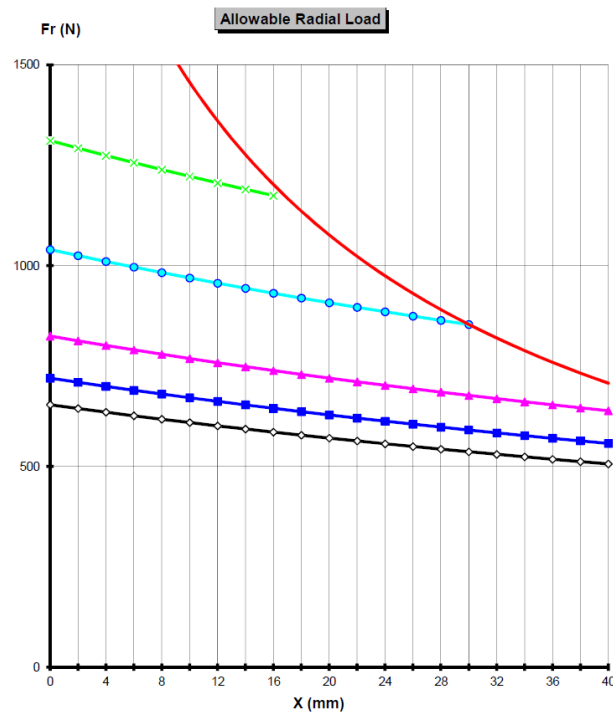

Life's time 20000 heures

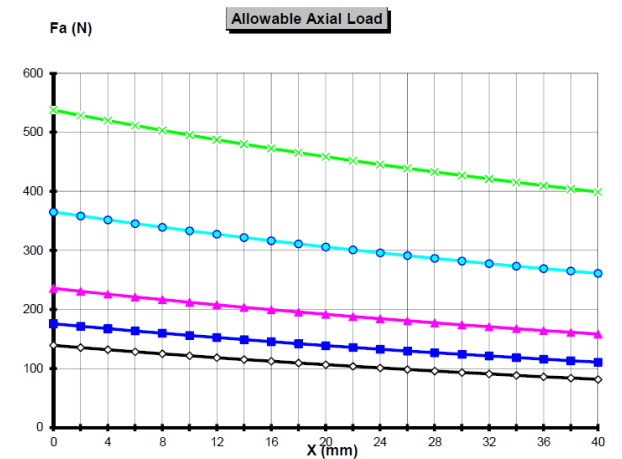
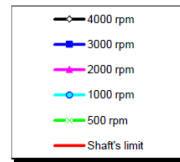
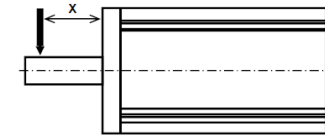

3.5.2.6. NX430

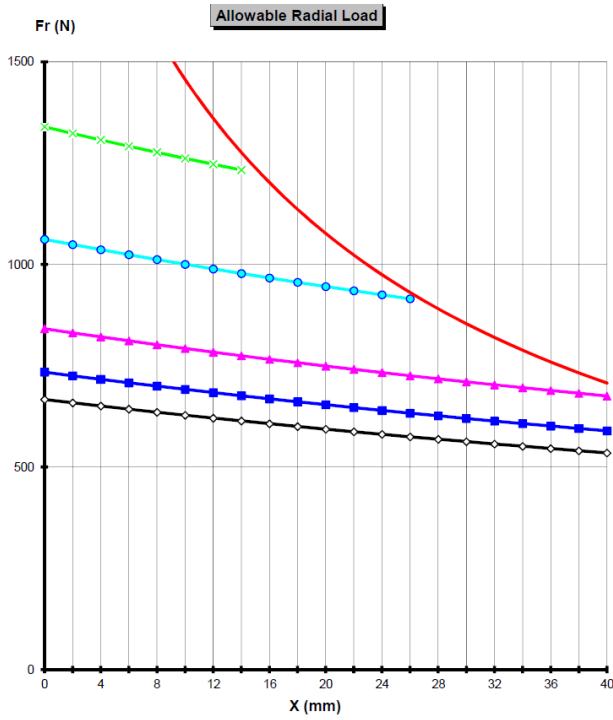

Life's time 20000 heures

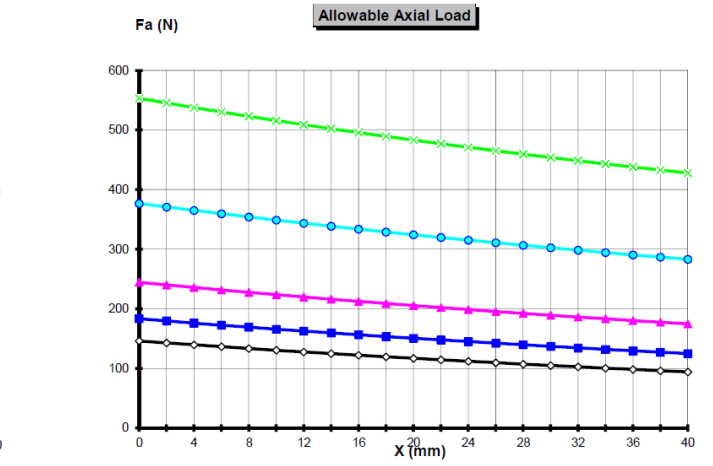
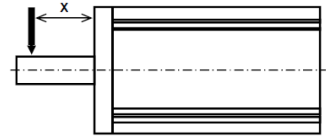

3.5.2.7. NX620

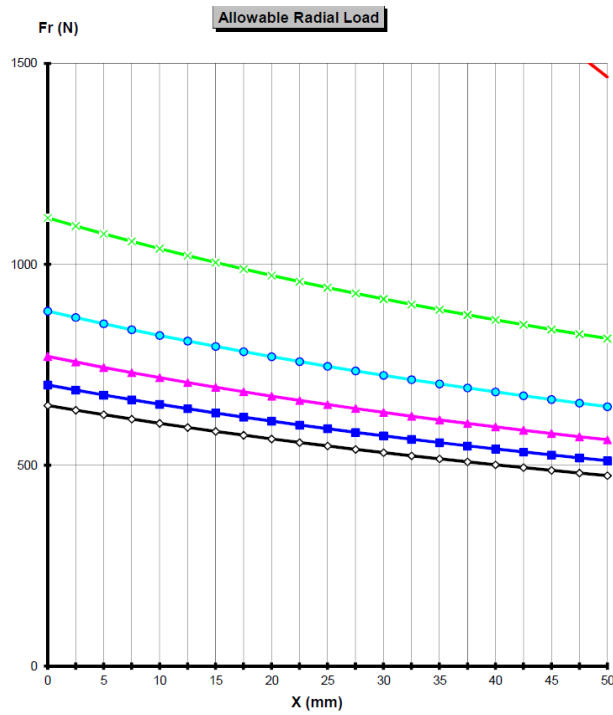

Life's time 20000 heures

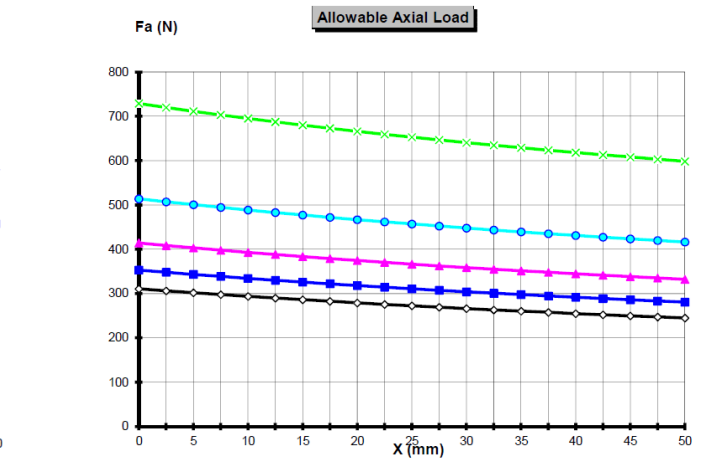
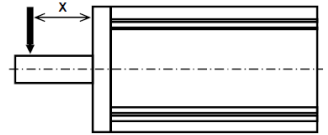

3.5.2.8. NX630

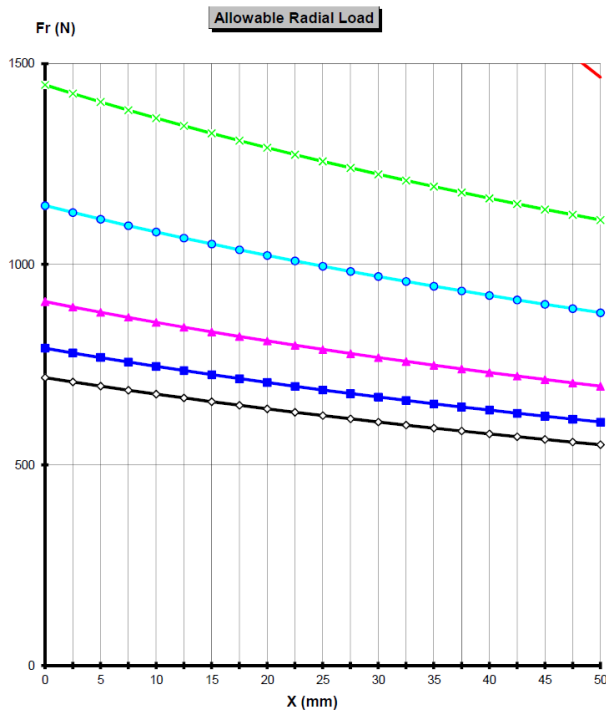

Life's time 20000 heures

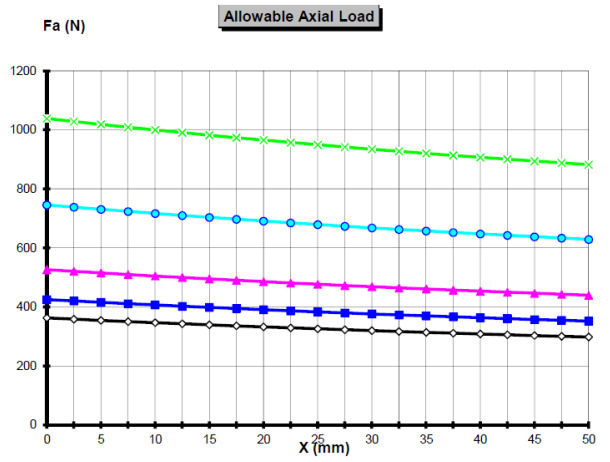
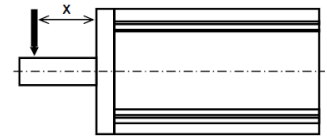

3.5.2.9. NX820

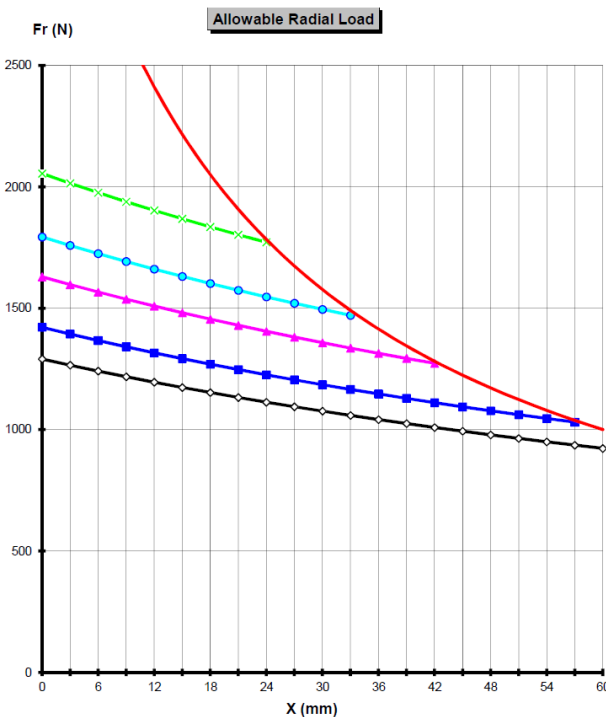

Life's time 20000 heures

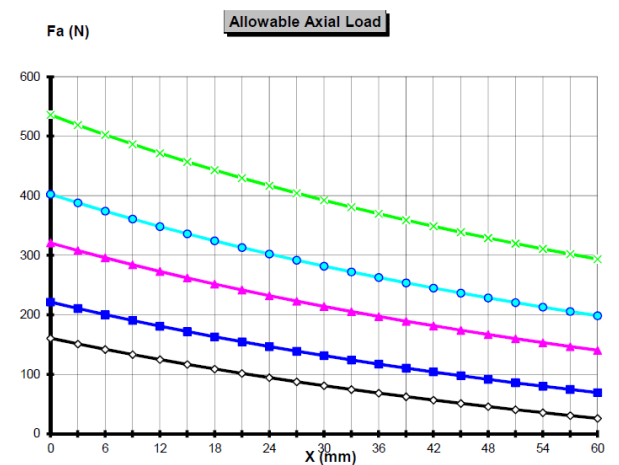
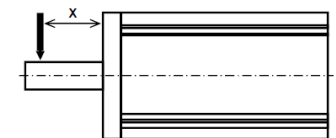

3.5.2.10. NX840

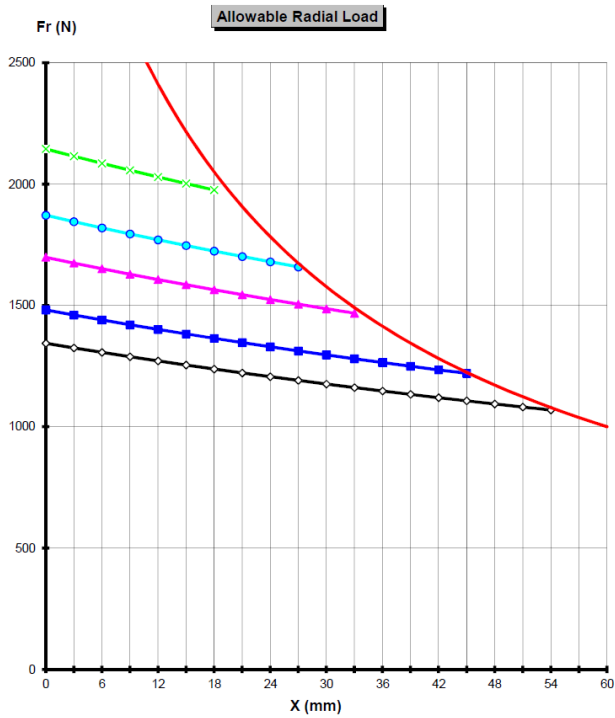

Life's time 20000 heures

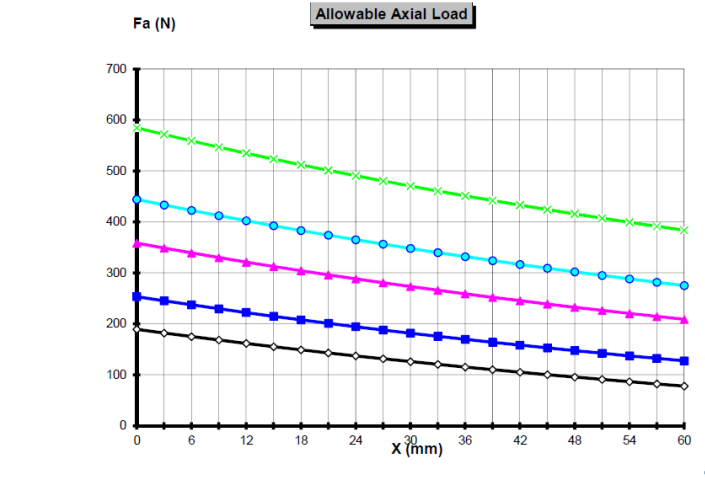
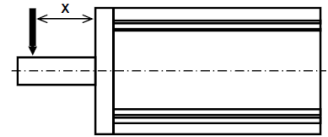

3.5.2.11. NX860

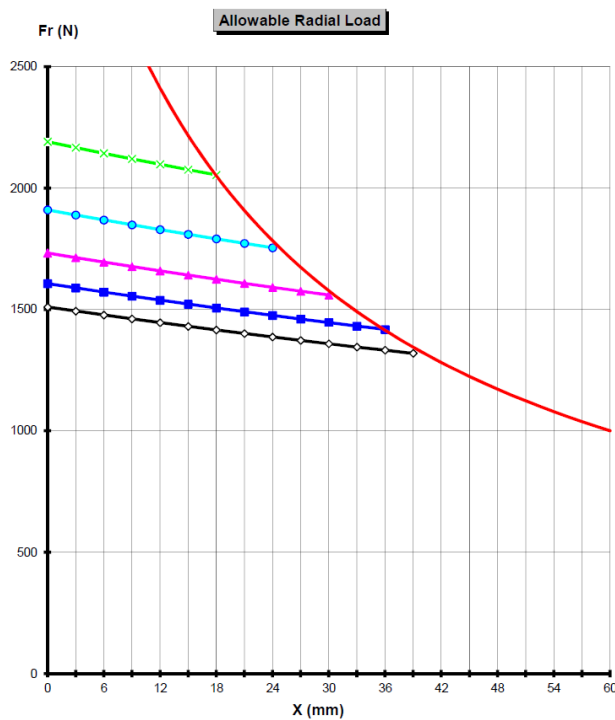

Life's time 20000 heures

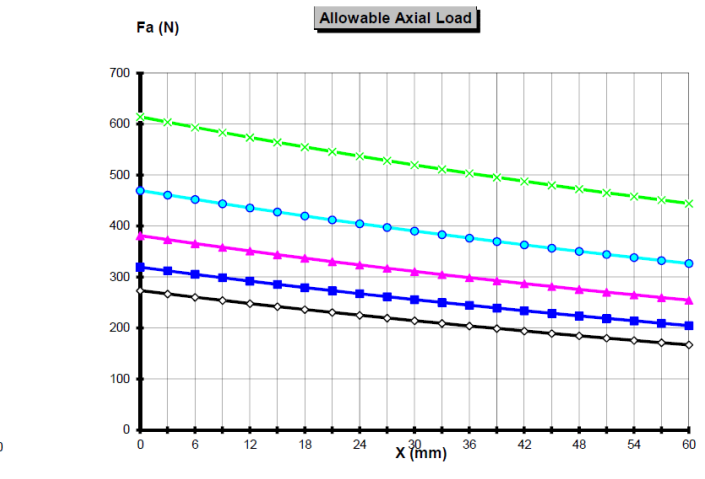
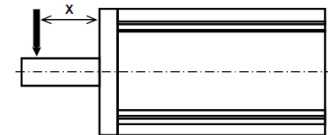







3.6. Cooling

In compliance with the IEC 60034-1 standards:

3.6.1. Natural and fan cooled motor

The ambient air temperature shall not be less than **-15°C** and more than **40°C**.

3.6.2. Water cooled motor

	<p><u>Danger:</u> The cooling system has to be operational when the motor is running or energized.</p>
	<p><u>Danger:</u> The Inlet temperature and the water flow have to be monitored to avoid any exceeding values.</p>
	<p><u>Caution:</u> When motor is not running, the cooling system has to be stopped 10 minutes after motor shut down.</p>
	<p><u>Caution:</u> Condensation and risk of rust may occur when the temperature gradient between the air and the water becomes significant. Condensation is also linked to hygrometry rate. To avoid any issue, we recommend: $T_{\text{water}} > T_{\text{air}} - 2^{\circ}\text{C}$. The motor can be used with an ambient temperature between 27°C to 40°C with a high water temperature but with derating. If inlet water temperature becomes higher than 25°C, derating factor must be applied according to §3.1.2 Temperature Derating</p>
	<p><u>Caution:</u> the ambient air temperature shall not exceed 40°C in the vicinity of the motor flange</p>
	<p><u>Danger:</u> If the water flow stops, the motor can be damaged or destroyed causing accidents.</p>

3.6.3. Additives for water as cooling media

Please refer to motor technical data for coolant flow rates.

The water inlet temperature must not exceed **25°C** without torque derating.
The water inlet temperature must not be below **5°C**.

The inner pressure of the cooling liquid must not exceed **5 bars**.

	<p><u>Caution:</u> To avoid the appearance of corrosion of the motor cooling system, the water must have anti-corrosion additive.</p>
---	---

The servomotors are water cooled. Corrosion inhibitors must be added to the water to avoid the corrosion. The complete cooling system must be taken into account to choose the right additive, this includes: the different materials in the cooling circuit, the chiller manufacturer recommendations, the quality of the water...

The right additive solution is under the responsibility of the user. Some additives like TYFOCOR or GLYSANTIN G48 correctly used have demonstrated their ability to prevent corrosion in a closed cooling circuit.

For example: Glysantin G48 recommendations are :

- Water hardness: 0 to 20°dH (0 – 3.6 mmol/l)
- Chloride content: max. 100ppm
- Sulphate content: max. 100ppm

	<p><u>Caution:</u> The water quality is very important and must comply with supplier recommendations. The additive quantity and periodic replacement must respect the same supplier recommendations.</p>
---	--

	<p><u>Caution:</u> The additive choice must take into account the global cooling system (chiller or water exchanger recommendations...).</p>
---	--

	<p>Select carefully the materials of all the cooling system parts (chiller, exchanger, hoses, adapters and fittings) because the difference between material galvanic potential can make corrosion.</p>
---	---



3.6.4. Motor cooling circuit drop pressure

The tab below describes the drop pressure at the water flow rate from the motor data:

Motor type	Drop pressure @ nominal water flow
NX860W	0.3 bar @ 5 l/min

Note : all motors drop pressure are checked before shipping.

3.6.5. Chiller selection

This section describes how to choose the chiller. The chiller is able to evacuate the heat from the motor losses with the water circulation.

The motor losses (= power to evacuate by the chiller) depend on the efficiency and motor power:

$$P_c = \left(\frac{1}{\rho} - 1 \right) \cdot P_n$$

With P_c : Power to evacuate by the chiller (kW)
 P_n : Nominal motor power (kW)
 ρ : motor efficiency at nominal power (%)

Refer to the respective motor data sheet for nominal power, efficiency and water flow. Chiller pump must provide water flow through motor and pipe pressure drop. Inlet temperature must be inferior to **25°C**.

Example

Motor : NX860W

For a torque of 80 N.m @ 2500 rpm, the efficiency is 92%.

Water flow = 5 l/min

$$P_n = 80 \times 2500 \times \pi / 30$$

$$P_n = 20.9 \text{ kW}$$

$$P_c = \left(\frac{1}{0.92} - 1 \right) \cdot 20.9 = \mathbf{1.8 \text{ kW}}$$

So, the chiller must evacuate 1.8 kW and has a water flow of 5 l/min for this point of running.

3.6.6. Flow derating according to glycol concentration

	Glycol concentration [%]					
	0	10	20	30	40	50
5	5.1	5.3	5.6	5.9	6.2	
10	10.2	10.6	11.1	11.8	12.4	
15	15.3	15.9	16.7	17.6	18.7	
20	20.4	21.2	22.2	23.5	24.9	
25	25.5	26.5	27.8	29.4	31.1	
30	30.6	31.8	33.4	35.3	37.3	
35	35.7	37.1	38.9	41.1	43.6	
40	40.8	42.4	44.5	47.0	49.8	
45	45.9	47.7	50.0	52.9	56.0	
50	51.0	53.0	55.6	58.8	62.2	
55	56.1	58.3	61.2	64.7	68.4	
60	61.2	63.5	66.7	70.5	74.7	
65	66.4	68.8	72.3	76.4	80.9	
70	71.5	74.1	77.8	82.3	87.1	
75	76.6	79.4	83.4	88.2	93.3	
80	81.7	84.7	89.0	94.1	99.5	
85	86.8	90.0	94.5	99.9	105.8	
90	91.9	95.3	100.1	105.8	112.0	
95	97.0	100.6	105.6	111.7	118.2	
100	102.1	105.9	111.2	117.6	124.4	
110	112.3	116.5	122.3	129.3	136.9	
120	122.5	127.1	133.4	141.1	149.3	
130	132.7	137.7	144.6	152.8	161.8	
140	142.9	148.3	155.7	164.6	174.2	
150	153.1	158.9	166.8	176.3	186.6	
160	163.3	169.5	177.9	188.1	199.1	
170	173.5	180.1	189.0	199.9	211.5	
180	183.7	190.6	200.2	211.6	224.0	
190	194.0	201.2	211.3	223.4	236.4	
200	204.2	211.8	222.4	235.1	248.9	

Use of the table above - Example

If the motor needs **25 l/min** with **0%** glycol,

If application needs **20%** glycol, the water flow must be **26.5 l/min**,

If application needs **40%** glycol, the water flow must be **29.4 l/min**.



Main formulas

$$Flow_rate = \frac{Power_dissipation * 60}{\Delta\theta * C_p}$$

With: *Flow rate* [l/min]
Power_dissipation [W]
 $\Delta\theta$ Gradient inlet-outlet [°C]
C_p thermal specific capacity of the water as coolant [J/kg°K]
(**C_p** depends on the % glycol concentration please see below)

Thermal specific capacity C_p according to % glycol concentration and temperature

We have considered an average temperature of the coolant of 30°C.

Glycol concentration [%]	Average temperature of the water as coolant [°C]	Thermal specific capacity of the water C_p [J/kg°K]
0	30	4176
30	30	3755
40	30	3551
50	30	3354

3.6.7. Water cooling diagram

	<p>Recommendation: The use of a filter allows to reduce the presence of impurities or chips in the water circuit in order to prevent its obstruction. We recommend 0.1mm filter.</p>
--	---

This section shows typical water cooling diagram :

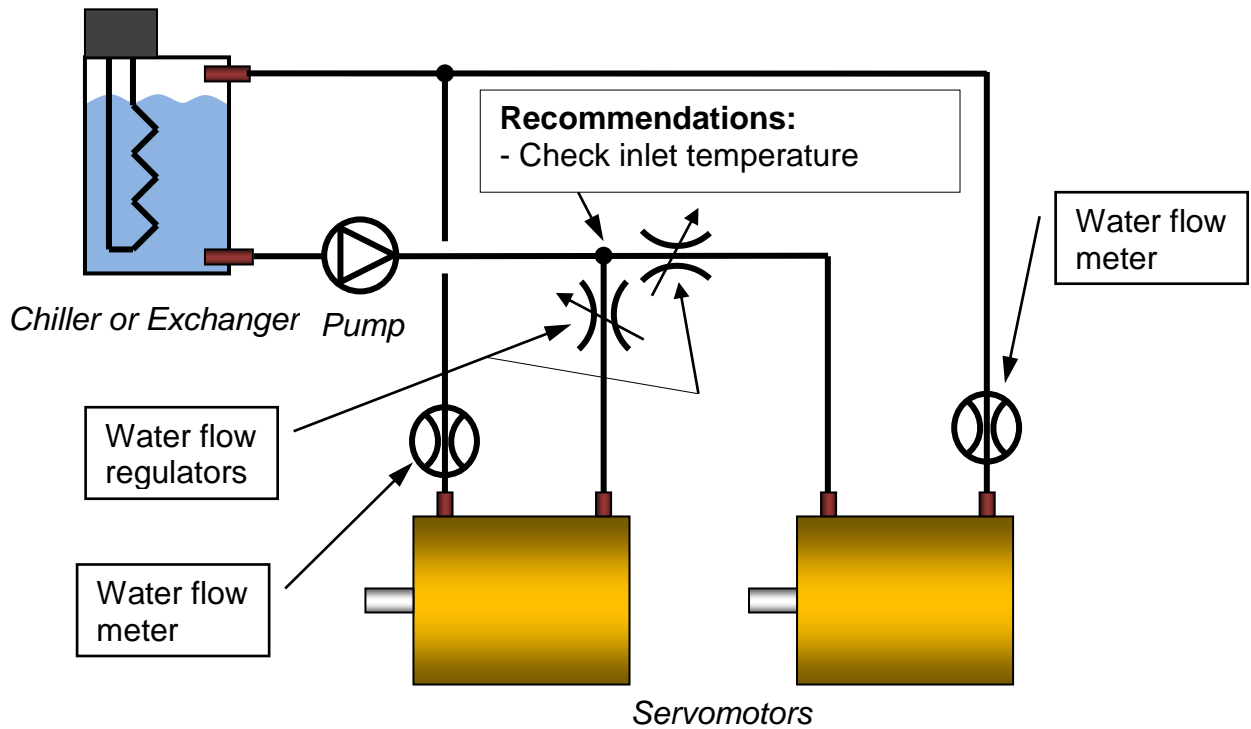
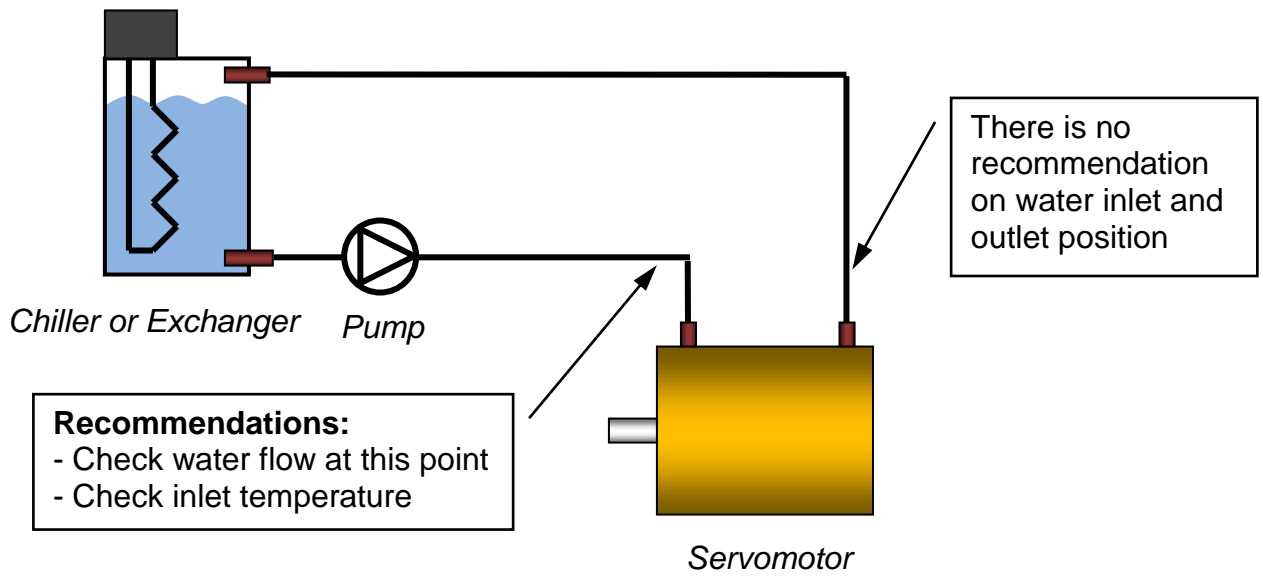

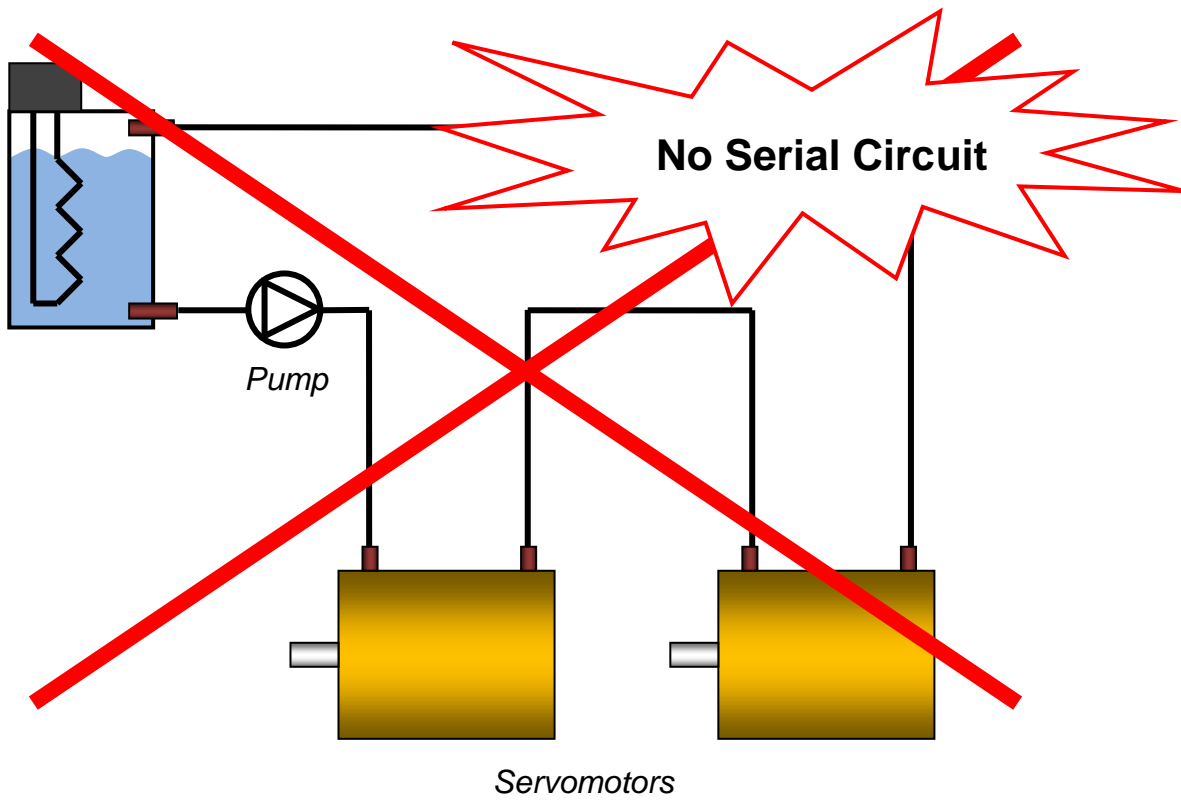
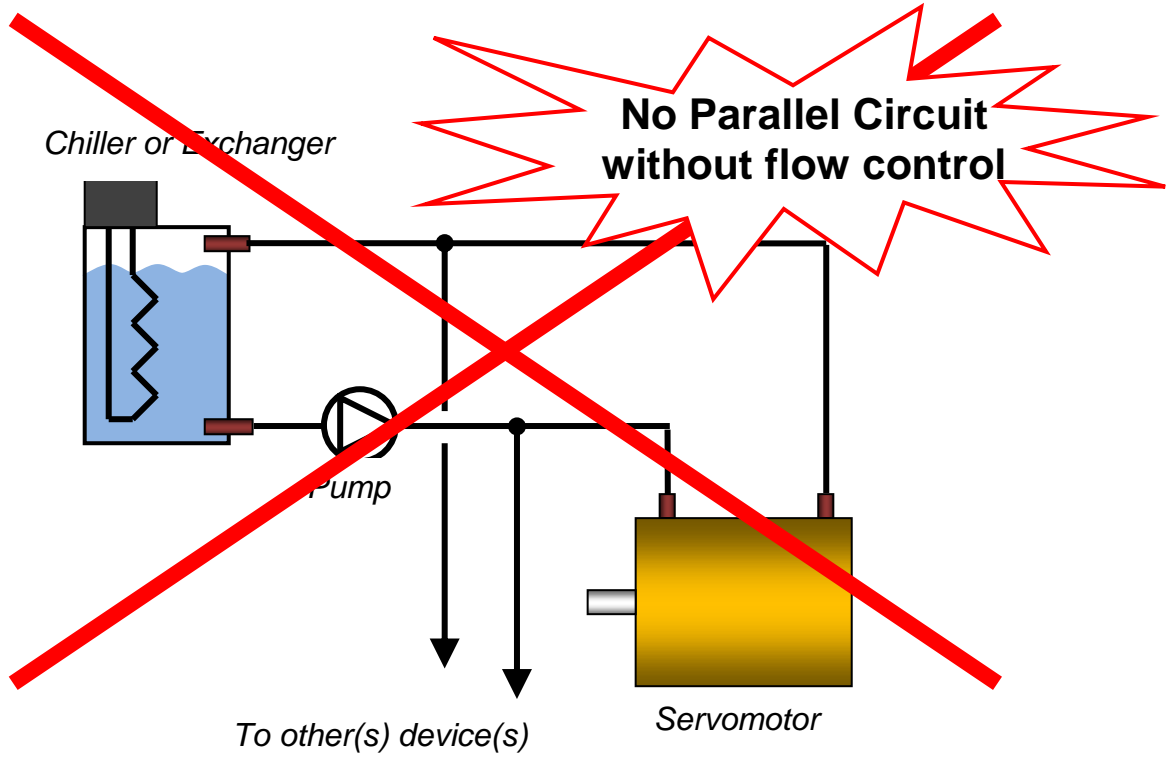

3.7. Thermal Protection

Different protections against thermal overloading of the motor are proposed as an option: Thermoswitch, PTC thermistors or KTY temperature built into the stator winding. No thermal protection are available for the NX1 motor

The thermal sensors, due to their thermal inertia, are unable to follow very fast winding temperature variations. They achieve their thermal steady state after a few minutes.

	<p>Warning: To protect correctly the motor against very fast overload, please refer to 3.1.6. Peak current limitations</p>
--	---

3.7.1. Alarm tripping with PTC thermistors :

One thermal probe (PTC thermistors) fitted in the NX servomotor winding trip the electronic system at $150^{\circ} \pm 5^{\circ} \text{C}$ for class F version. When the rated tripping temperature is reached, the PTC thermistor undergoes a step change in resistance. This means that a limit can be easily and reliably detected by the drive.

The graph and tab below shows PTC sensor resistance as a function of temperature (T_N is nominal temperature)

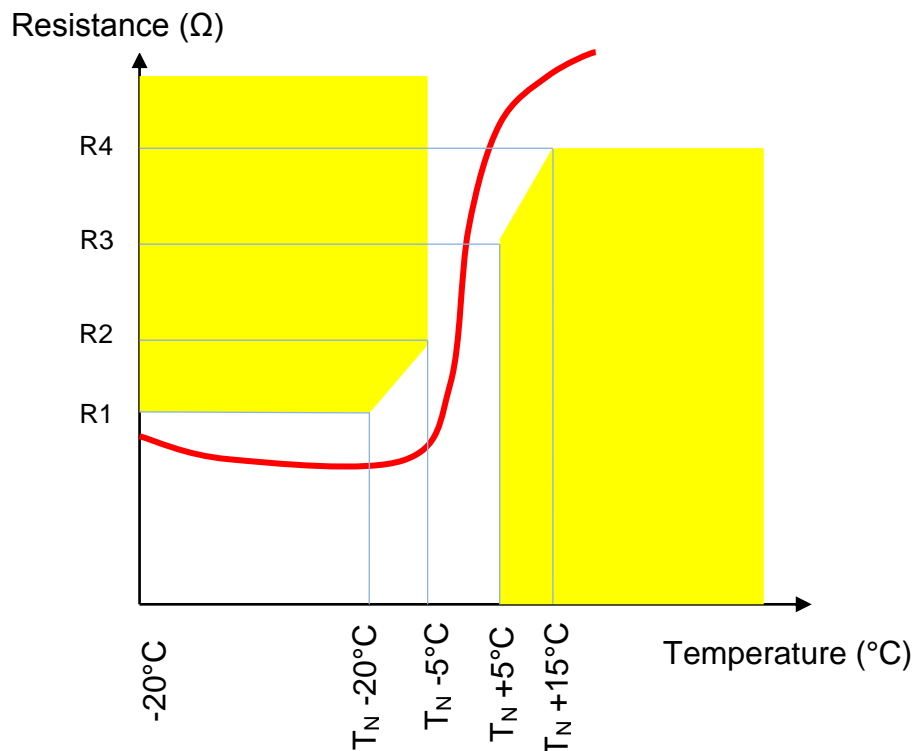

Temperature	Resistance value for NX2, NX6 and NX8	Resistance value for NX3 and NX4
-20°C up to $T_N - 20^{\circ}\text{C}$	$R1 \leq 500\Omega$	$R1 \leq 750\Omega$
$T_N - 5^{\circ}\text{C}$	$R2 \leq 1100\Omega$	$R2 \leq 1650\Omega$
$T_N + 5^{\circ}\text{C}$	$R3 \geq 2660\Omega$	$R3 \geq 3990\Omega$
$T_N + 15^{\circ}\text{C}$	$R4 \geq 8000\Omega$	$R4 \geq 12000\Omega$

3.7.2. Temperature measurement with KTY sensors:

Motor temperature can also be continuously monitored by the drive using a KTY 84-130 thermal sensor built in to the stator winding. KTY sensors are semiconductor sensors that change their resistance according to an approximately linear characteristic. The required temperature limits for alarm and tripping can be set in the drive.

The graph below shows KTY sensor resistance vs temperature, for a measuring current of 2 mA:

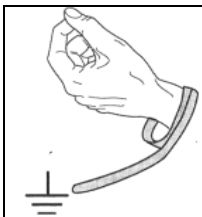
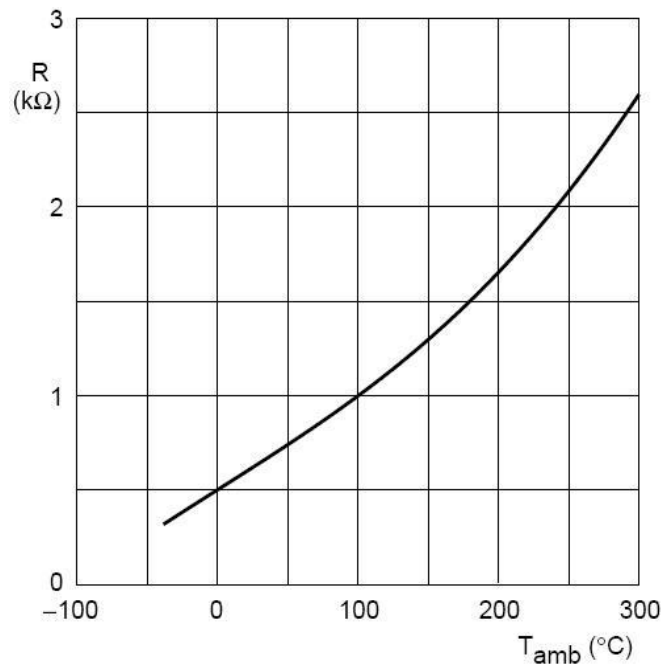

Warning: KTY sensor is sensitive to electrostatic discharge. So, always wear an antistatic wrist strap during KTY handling.



Warning: KTY sensor is polarized. Do not invert the wires.



Warning: KTY sensor is sensitive. Do not check it with an Ohmmeter or any measuring or testing device.

3.8. Power Electrical Connections

3.8.1. Wires sizes

	<p>In every country, you must respect all the local electrical installation regulations and standards.</p>
---	--

Not limiting example in France: NFC 15-100 or IEC 60364 as well in Europe.

	<p>Cable selection depends on the cable construction, so refer to the cable technical documentation to choose wire sizes</p>
---	--

	<p>Some drives have cable limitations or recommendations; please refer to the drive technical documentation for any further information.</p>
--	--

Cable selection

	<p>At standstill, the current must be limited at 80% of the low speed current I_o and cable has to support peak current for a long period. So, if the motor works at standstill, the current to select wire size is $\sqrt{2} \times 0.8 I_o \cong 1,13 \times I_o$.</p>
---	--

Sizes for H07 RN-F cable, for a 3 cores in a cable tray at 30°C max

Section [mm ²]	I_{max} [A _{rms}]
1.5	17
2.5	23
4	31
6	42
10	55
16	74
25	97
35	120
50	146
70	185
95	224
120	260
150	299
185	341
240	401
300	461



Example of sizes for H07 RN-F cable :

Conditions of use:

Case of 3 conductors type H07 RN-F: **60°C maximum**

Ambient temperature: 30°C

Cable runs on dedicated cables ways

Current limited to 80%*I₀ at low speed or at motor stall.

Example:

I₀=100 Arms

Permanent current at standstill : 80 Arms

Max permanent current in the cable = 113 Arms

Cable section selection = 35mm² for a 3 cores in a cable tray at 30°C max.

You also have to respect the Drive commissioning manual and the cables current densities or voltage specifications

3.8.2. Conversion Awg/kcmil/mm²:

Awg	kcmil	mm ²
	500	253
	400	203
	350	177
	300	152
	250	127
0000 (4/0)	212	107
000 (3/0)	168	85
00 (2/0)	133	67.4
0 (1/0)	106	53.5
1	83.7	42.4
2	66.4	33.6
3	52.6	26.7
4	41.7	21.2
5	33.1	16.8
6	26.3	13.3
7	20.8	10.5
8	16.5	8.37
9	13.1	6.63
10	10.4	5.26
11	8.23	4.17
12	6.53	3.31
14	4.10	2.08
16	2.58	1.31
18	1.62	0.82
20	1.03	0.52
22	0.63	0.32
24	0.39	0.20
26	0.26	0.13

3.8.3. Motor cable length

For motors windings which present low inductance values or low resistance values, the own cable inductance, respectively own resistance, in case of large cable length can greatly reduce the maximum speed of the motor. Please contact PARKER for further information.



Caution: It might be necessary to fit a filter at the servo-drive output if the length of the cable exceeds 25 m. Consult us.

3.8.4. Mains supply connection diagrams

<p>POWER CABLE</p> <p>Motor Size : NX1/2 Cable diameter : $\varnothing 9.5$ Shielded Pairs POWER : 4 x 0.5 mm² black : phase U white : phase V red : phase W yellow/green : ground ACCESSORIES : 2 x (2 x 0.5 mm²) Yellow : No connection Orange : No connection Green/Blue : Brake - Green/Red : Brake +</p> <p style="text-align: right;">} If the option is required</p>	<p>POWER CABLE</p> <p>Motor Size : NX3/4/6 Cable diameter : $\varnothing 11.8$ Twisted and shielded pairs + overall shield POWER : 4 x 1.5 mm² black 1 : phase U black 2 : phase V black 3 : phase W yellow/green : ground ACCESSORIES : 1 x (2 x 1 mm²) Black : Brake - White : Brake +</p> <p style="text-align: right;">} If the option is required</p>	<p>SIGNAL CABLE</p> <p>Motor Size : NX1/2 Feedback Letter : A Cable diameter : $\varnothing 7.1$ Twisted and shielded pairs + overall shield SIGNAL CABLE : 6 x 0.24 mm² Red/white : R1 Yellow : S2 Black/white : R2 Blue : S3 Red : S1 Blue : S4 Black/Blue : S2)</p> <p style="font-size: small;">S1 = Cos - S2 = Sin - R1 = excitation + S3 = Cos + S4 = Sin + R2 = excitation -</p> <p style="font-size: x-small;">Note: Is relating in clock wise viewed from shaft end view.</p> <p>ENCODER SETTINGS</p> <p>Feedback Letter : A Motor powered by direct current at the current nominal value (W + et V-), (W + and V-), the shift is 90° electrical.</p> <p>Feedback Letter : R/S Motor powered by direct current at the current nominal value (W + et V-), value in encoder memory is 205</p> <p>Feedback Letter : T/U Motor powered by direct current at the current nominal value (W + et V-), value in encoder memory is 1638</p> <p>Feedback Letter : V/W Motor powered by direct current at the current nominal value (W + et V-), value in encoder memory is 470</p> <p>Feedback Letter : X Engine driven clockwise shaft end side. Switching signal V is in phase with FEET UV.</p>
<p>POWER CABLE</p> <p>Motor Size : NX1/2 Cable diameter : $\varnothing 9.5$ Shielded Pairs POWER : 4 x 0.5 mm² black : phase U white : phase V red : phase W yellow/green : ground ACCESSORIES : 2 x (2 x 0.5 mm²) Yellow : No connection Orange : No connection Green/Blue : Brake - Green/Red : Brake +</p> <p style="text-align: right;">} If the option is required</p>	<p>POWER CABLE</p> <p>Motor Size : NX3/4/6 Cable diameter : $\varnothing 11.8$ Twisted and shielded pairs + overall shield POWER : 4 x 1.5 mm² black 1 : phase U black 2 : phase V black 3 : phase W yellow/green : ground ACCESSORIES : 1 x (2 x 1 mm²) Black : Brake - White : Brake +</p> <p style="text-align: right;">} If the option is required</p>	<p>SIGNAL CABLE</p> <p>Motor Size : NX1/2 Feedback Letter : A Cable diameter : $\varnothing 7.1$ Twisted and shielded pairs + overall shield SIGNAL CABLE : 6 x 0.24 mm² Red/white : R1 Yellow : S2 Black/white : R2 Blue : S3 Red : S1 Blue : S4 Black/Blue : S2)</p> <p style="font-size: small;">S1 = Cos - S2 = Sin - R1 = excitation + S3 = Cos + S4 = Sin + R2 = excitation -</p> <p style="font-size: x-small;">Note: Is relating in clock wise viewed from shaft end view.</p> <p>ENCODER SETTINGS</p> <p>Feedback Letter : A Motor powered by direct current at the current nominal value (W + et V-), (W + and V-), the shift is 90° electrical.</p> <p>Feedback Letter : R/S Motor powered by direct current at the current nominal value (W + et V-), value in encoder memory is 205</p> <p>Feedback Letter : T/U Motor powered by direct current at the current nominal value (W + et V-), value in encoder memory is 1638</p> <p>Feedback Letter : V/W Motor powered by direct current at the current nominal value (W + et V-), value in encoder memory is 470</p> <p>Feedback Letter : X Engine driven clockwise shaft end side. Switching signal V is in phase with FEET UV.</p>

Temperature Sensor on Power Connector

0 : Base
1 : PTC
2 : Thermoswitch
6 : KTY

3 : Brake
4 : Brake + PTC
5 : Brake + Thermoswitch
7 : Brake + KTY

Temperature Sensor on Signal Connector

A : PTC
B : Thermoswitch
C : KTY

D : Brake + PTC
E : Brake + Thermoswitch
F : Brake + KTY

Temperature Sensor on Signal Connector

0 : Plain Shaft
1 : Key
0 : IP 64
1 : IP 65

Motor Size : NX2/3/4/6
Feedback Letter : X
Cable diameter : $\varnothing 10.8$
Twisted and shielded pairs + overall shield
SIGNAL CABLE : 5 x (2x 0.25 mm²)
Pair 1 : (Black : GND Red : VCC)
Pair 2 : (Black : A+ Green : A-)
Pair 3 : (Black : B+ Blue : B-)
Pair 4 : (Black : Z White : U)
Pair 5 : (Black : V Yellow : W)

Sheet : 1/7

Parker		NX MOTORS CONNECTIONS	
8, Avenue du Lac, BP249 21007-DJON, cedex-FRANCE www.SSDrive.com		Format	A3
CABLE VARIANT		F	E
344993		S	G
H		I	I

Power output
Output wires inside Ø29 PVC sheath
Overall shielding connected to ground
Wire, shielding, sheath: Ends not stripped

Signal output
Output wires inside Ø27 PVC sheath
Overall shielding connected to ground
Wire, shielding, sheath: Ends not stripped

N X - - - E - - R 4

Torque range (depends on length)
Winding (depends on speed)

0 : Plain Shaft
1 : key
0 : IP 64
1 : IP 65

B : Hiperface Singleturn SKS 36 - 128
S : Hiperface Multiturn SKM 36 - 128
X : Low Cost Encoder - Z046

Temperature Sensor on Power Connector

A : PTC
3 : Brake
4 : Brake + PTC
2 : Thermoswitch
5 : Brake + Thermoswitch
6 : KTY
7 : Brake + KTY

Temperature Sensor on Signal Connector

A : PTC
D : Brake + PTC
B : Thermoswitch
E : Brake + Thermoswitch
C : KTY
F : Brake + KTY

** Except for encoders Q/R/S : the output cable is the encoder's cable

POWER CABLE

Motor Size : NX1/2
Length : 1000 mm
POWER : 4 x 0.5 mm²

black : phase U
white : phase V
red : phase W
yellow/green : ground

BRAKE : 2 x 0.14 mm²
green/red : +
green/blue : -

Brake wires outside shielding

SIGNAL CABLE

Motor Size : NX1/2
Feedback Letter : A
Length : 1000 mm
SIGNAL : 6 x 0.08 mm², AWG28

red/white : R1
yellow/white : R2
black : S1
yellow : S2
red : S3
blue : S4

S1 = Cos - S2 = Sin - R1 = excitation +
 S3 = Cos + S4 = Sin + R2 = excitation -

Note: is rotating in clock wise viewed from shaft end view.

ENCODER SETTINGS

Feedback Letter : A Feedback Letter : R/S Feedback Letter : X

Motor powered by direct current at the current nominal value (W+ et V-), (W+ and V-), the shift is 90° electrical.

Motor powered by direct current at the current nominal value (W+ et V-), (W+ and V-), the shift is 90° electrical.

General tolerances

DIN ISO 2768 mK

Drawn	03/07/09	YG	Visa
C	AM 23433	- 08/07/10 - 00	F AM 23892, 26/06/12 PR
H	AM 24108, 22/04/13 SD		E AM 23624, 26/05/11 YG
G	AM 23924, 26/07/12 PR		D AM 23533 - 26/01/11 - 00

Scale /

Parker
8, Avenue du lac, BP249
ZI de la Chapelle
21007 PAYSANNE
www.ssdforives.com

NX MOTORS CONNECTIONS

Format A3

FLYING WIRES VARIANT

344993

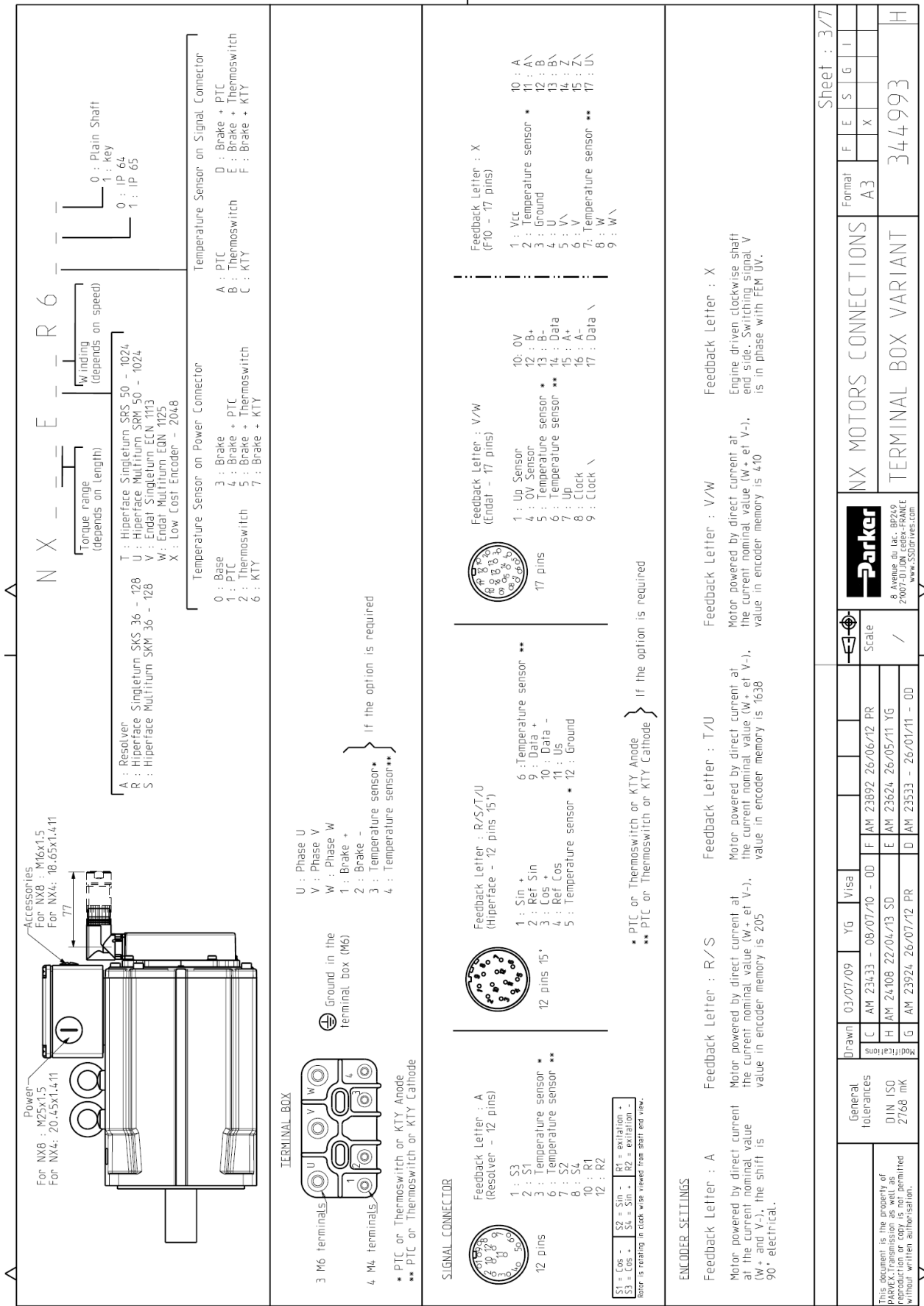

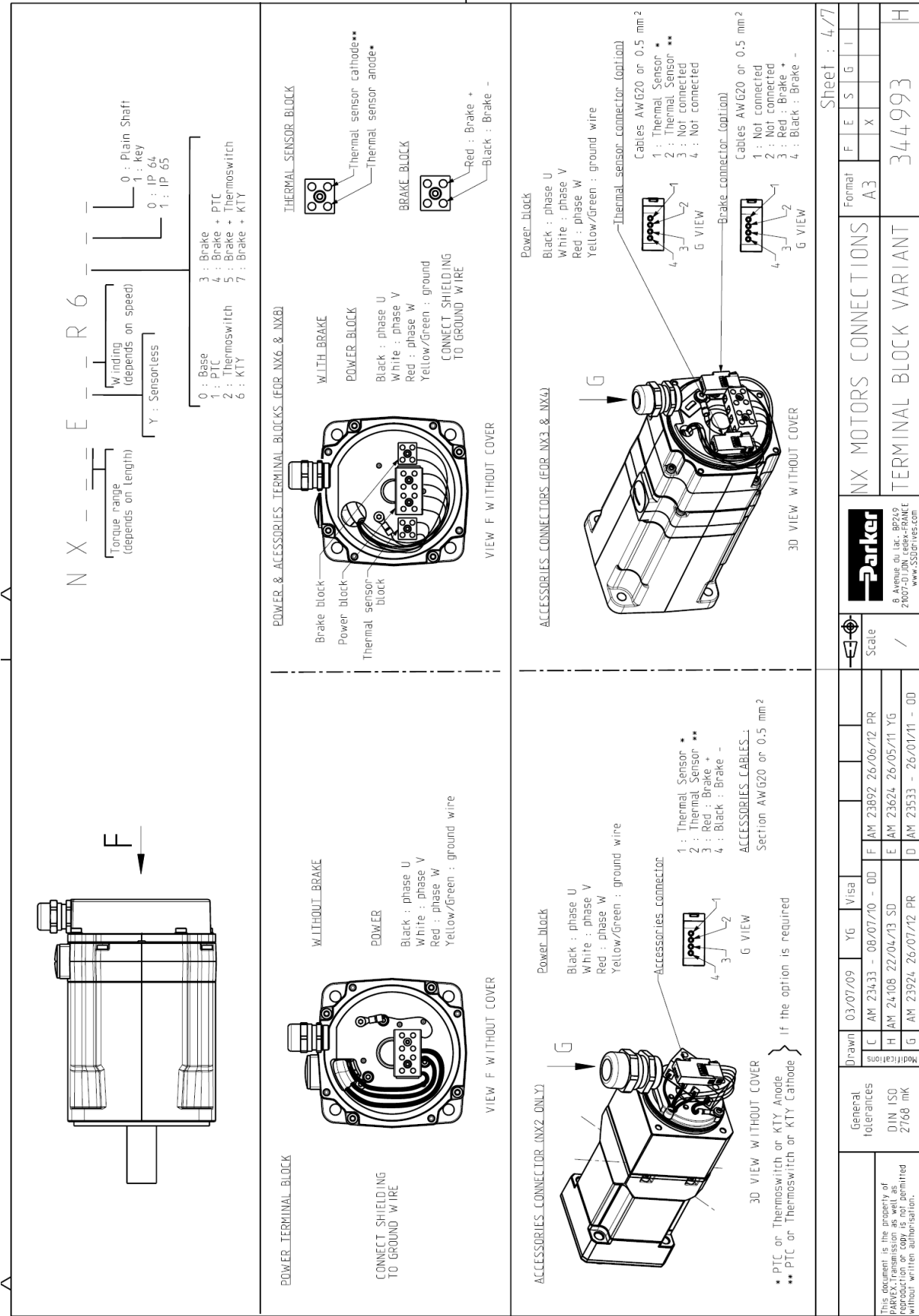

Sheet : 4/7

Format	A3
--------	----

NX MOTORS CONNECTIONS

TERMINAL BLOCK VARIANT

344993



Scale	/
-------	---

Drawn	03/07/09	YG	Visa	
Modifications	C AM 23433 - 08/07/10 - 00	F	AM 23892 26/06/12 PR	
	H AM 24108 22/04/13 SD	E	AM 23624 26/05/11 YG	
	G AM 23924 26/07/12 PR	D	AM 23533 - 26/01/11 - 00	

General tolerances
DIN ISO 2768 mK

This document is the property of PARKER. Transmission as well as reproduction or copy is not permitted without written authorisation.

NX - E - T - R 7

101

77

0 : Plain Shaft
1 : Key
0 : IP 64
1 : IP 65

Winding (depends on speed)

Torque range (depends on length)

T : Hyperface Singleturn SKS 50 - 1024
U : Hyperface Multiturn SRM 50 - 1024
V : Endat Singleturn ECN 1113
W : Endat Multiturn EGN 1125
X : Low Cost Encoder - 2048
Y : Sensorless

Temperature Sensor on Power Connector

0 : Base
1 : PTC
2 : Thermoswitch
3 : Brake
4 : Brake + PTC
5 : Brake + Thermoswitch
6 : KTY
7 : Brake + KTY

Temperature Sensor on Signal Connector

A : PTC
B : Thermoswitch
C : KTY
D : Brake + PTC
E : Brake + Thermoswitch
F : Brake + KTY

EXCEPT NX1 MOTORS

POWER CONNECTOR

3 : Phase W
2 :
1 : Phase U
4 : Phase V

A : Brake +
B : Brake
C : Temperature sensor
D : Temperature sensor

* PTC or Thermoswitch or KTY Anode
** PTC or Thermoswitch or KTY Cathode

If the option is required

SIGNAL CONNECTOR

Feedback Letter : A (Resolver - 12 pins)
1 : S3
2 : S1
3 : Temperature sensor
6 : Temperature sensor
7 : S2
8 : S4
10 : R1
12 : R2

Feedback Letter : R/S (Hyperface - 12 pins 15°)
1 : Sin +
2 : Ref Sin
3 : Cos +
4 : Ref Cos
5 : Temperature sensor
6 : Temperature sensor
9 : Data -
10 : Data +
11 : Us
12 : Ground

Feedback Letter : V/W (Endat - 17 pins)
1 : Up Sensor
4 : 0V Sensor
5 : Temperature sensor
6 : Temperature sensor
7 : Up
8 : Clock
9 : Clock
10 : 0V
12 : B+
13 : B-
14 : Data
15 : A+
16 : A-
17 : Data

Feedback Letter : X (F10 - 17 pins)
1 : Vcc
2 : Temperature sensor
3 : Ground
4 : U
5 : V
6 : V
7 : Temperature sensor
8 : W
9 : W
10 : A
11 : A
12 : B
13 : B
14 : Z
15 : Z
16 : V
17 : U

ENCODER SETTINGS

Feedback Letter : A Motor powered by direct current at the current nominal value (W+ and V-), the shift is 90° electrical.

Feedback Letter : R/S Motor powered by direct current at the current nominal value (W+ et V-), value in encoder memory is 205

Feedback Letter : T/U Motor powered by direct current at the current nominal value (W+ et V-), value in encoder memory is 1638

Feedback Letter : V/W Motor powered by direct current at the current nominal value (W+ et V-), value in encoder memory is 410

Feedback Letter : X Engine driven clockwise shaft end side. Switching signal V is in phase with FEM UV.

Drawn	03/07/09	YG	Visa	Scale
C	AM 23433	- 08/07/10 - 00	F	AM 23892 26/06/12 PR
H	AM 24108	22/04/13 SD	E	AM 23624 26/05/11 YG
G	AM 23924	26/07/12 PR	D	AM 23533 - 26/01/11 - 00

General Tolerances
DIN ISO 2768 mK

This document is the property of PARKEX Transmission as well as reproduction or copy is not permitted without written authorisation.

Sheet : 5/7

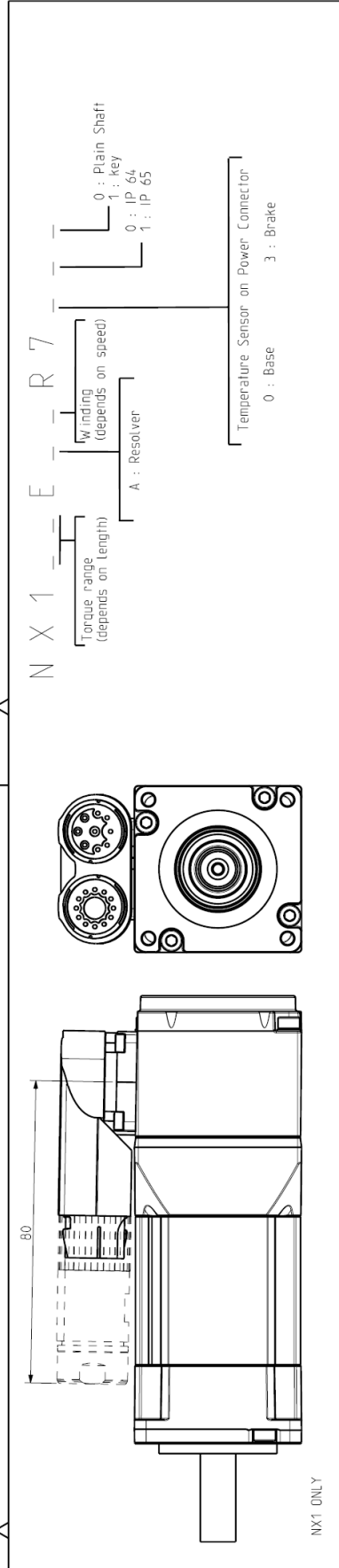

POWER CONNECTOR

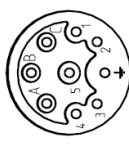

- A : Phase U
 - B : Phase V
 - C : Phase W
 - Ground
 - 1 : Brake +
 - 2 : Brake -
- } If the option is required.

SIGNAL CONNECTOR

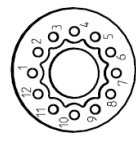

Feedback Letter : A
(Resolver - 12 pins)

- 1 : S3
- 2 : S1
- 7 : S2
- 8 : S4
- 10 : R1
- 12 : R2

S3 = Co - S4 = Sin - R1 = Excitation + R2 = Excitation -
Note: Is relating in each was viewed from shaft end view.

ENCODER SETTINGS

Feedback Letter : A

Motor powered by direct current at the current nominal value (W+ and V-), the shift is 90° electrical.

Sheet : 6/7	
NX MOTORS CONNECTIONS	Format A3
CONNECTOR VARIANT 344993	
 8, Avenue du lac, BP249 21007 VILLENEUVE V. FRANCE www.SSDPines.com	
Scale /	/
Drawn	03/07/09 YG Visa
General tolerances	C AM 23433 - 08/07/10 - 00 F AM 23892, 26/06/12 PR
DIN ISO 2768 mK	H AM 24108, 22/04/13 SD E AM 23624, 26/05/11 YG
Modifications	G AM 23924, 26/07/12 PR D AM 23533 - 26/01/11 - 00
This document is the property of Parker Hannifin Corporation. Its reproduction or copy is not permitted without written authorization.	

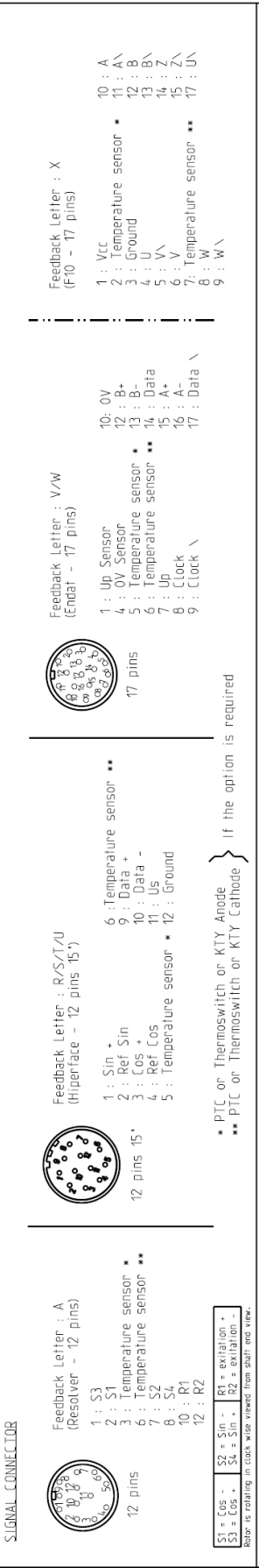
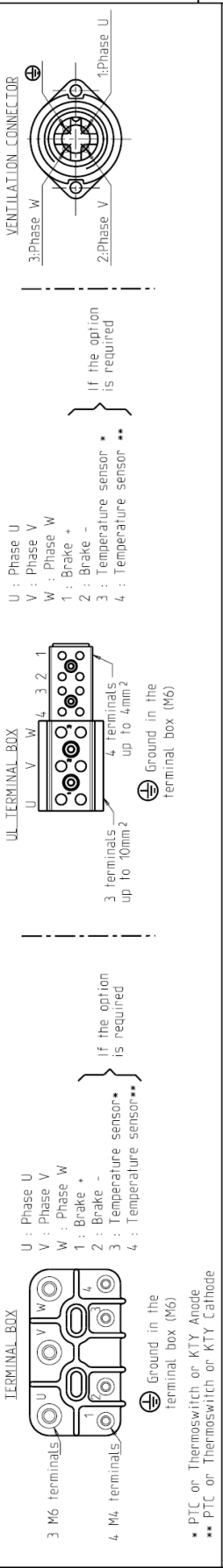
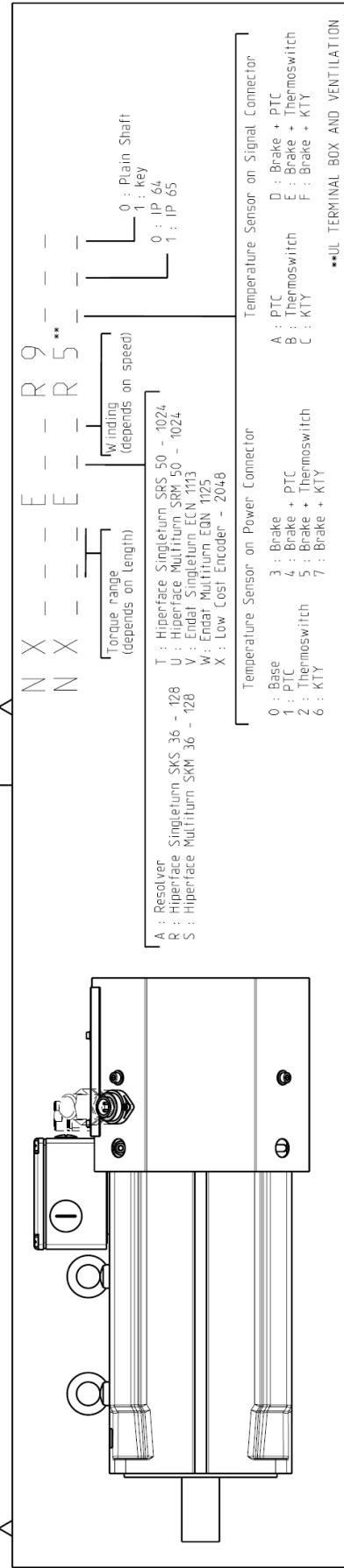

General tolerances DIN ISO 2768 mk		Drawn C AM 23433 - 08/07/10 - 00 H AM 24108 - 22/04/13 SD G AM 23924 - 26/07/12 PR	YG /	Visa /	Scale /	Parker 8 Avenue du Lac, BP249 21007-DIJON cedex-FRANCE www.3SDinves.com	NX MOTORS CONNECTIONS Format A3	F E S G I X	Sheet : 7/7
This document is the property of PARKEX. Transmission as well as reproduction without written authorization, without written authorization.		TERMINAL BOX VARIANT 344993							

3.9. Feedback system

3.9.1. Resolver 2 poles transformation ratio = 0.5 – code A

	NX1	NX2 & NX3	NX4, NX6 & NX8
Parker part number	220005P1000	220005P1001	220005P1002
Electrical specification	Values @ 8 kHz		
Polarity	2 poles		
Input voltage	7 Vrms		
Input current	70mA maximum	86mA maximum	
Zero voltage	20mV maximum		
Encoder accuracy	$\pm 10'$ maxi		
Ratio	0,5 \pm 5 %		
Output impedance (primary in short circuit whatever the position of the rotor)	Typical 120 + 200j Ω		
Dielectric rigidity (50 – 60 Hz)	500 V – 1 min		
Insulation resistance	$\geq 10M\Omega$	$\geq 100M\Omega$	
Rotor inertia	$\sim 6 \text{ g.cm}^2$	$\sim 30 \text{ g.cm}^2$	
Operating temperature range	-55 to +155 $^{\circ}\text{C}$		

3.9.2. Hiperface encoder singleturn SKS36 (128pulses) – code R

	NX1	NX2, NX3, NX4, NX6 & NX8
Model	N/A	SKS36 (Sick)
Type		Absolute single turn encoder
Parker part number		220174P0003
Line count		128 sine/cosine periods per revolution
Electrical interface		Hiperface
Position values per revolution		4096
Error limits for the digital absolute value		$\pm 320''$ (via RS485)
Integral non-linearity		$\pm 80''$ (Error limits for evaluating sine/cosine period)
Differential non-linearity		$\pm 40''$ (Non-linearity within a sine/cosine period)
Perating speed		12 000 rpm
Power Supply Current consumption (without load)		7VDC to 12VDC 60mA
Output frequency		0kHz – 65kHz
Operating temperature range		-20 $^{\circ}\text{C}$ to +110 $^{\circ}\text{C}$



3.9.3. Hiperface encoder multiturn SKM36 (128pulses) – code S

	NX1	NX2, NX3, NX4, NX6 & NX8
Model	N/A	SKM36 (Sick)
Type		Absolute multi turn encoder
Parker part number		220174P0004
Line count		128 sine/cosine periods per revolution
Electrical interface		Hiperface
Position values per revolution		4 096
Revolutions		4 096
Error limits for the digital absolute value		$\pm 320''$ (via RS485)
Integral non-linearity		$\pm 80''$ (Error limits for evaluating sine/cosine period)
Differential non-linearity		$\pm 40''$ (Non-linearity within a sine/cosine period)
Perating speed		9000 rpm
Power Supply Current consumption (without load)		7VDC to 12VDC 60mA
Output frequency		0kHz – 65kHz
Operating temperature range		-20°C to +110 °C

3.9.4. Hiperface encoder singleturn SRS50 (1024pulses) – code T

	NX1 & NX2	NX3, NX4, NX6 & NX8
Model	N/A	SRS50 (Sick)
Type		Absolute single turn encoder
Parker part number		220174P0002
Line count		1024 sine/cosine periods per revolution
Electrical interface		Hiperface
Position values per revolution		32 768
Integral non-linearity		$\pm 45''$ (Error limits for evaluating sine/cosine period)
Differential non-linearity		$\pm 7''$ (Non-linearity within a sine/cosine period)
Perating speed		6 000 rpm
Power Supply Current consumption (without load)		7VDC to 12VDC 80mA
Output frequency		0kHz – 200kHz
Operating temperature range		-30°C to +115 °C



3.9.5. Hiperface encoder multiturn SRM50 (1024pulses) – code U

	NX1 & NX2	NX3, NX4, NX6 & NX8
Model	N/A	SRM50 (Sick)
Type		Absolute multi turn encoder
Parker part number		220174P0001
Line count		1024 sine/cosine periods per revolution
Electrical interface		Hiperface
Position values per revolution		32 768
Revolutions		4 096
Integral non-linearity		$\pm 45''$ (Error limits for evaluating sine/cosine period)
Differential non-linearity		$\pm 7''$ (Non-linearity within a sine/cosine period)
Perating speed		6 000 rpm
Power Supply		7VDC to 12VDC 80mA
Current consumption (without load)		
Output frequency		0kHz – 200kHz
Operating temperature range		-30°C to +115 °C

3.9.6. Endat encoder singleturn ECN1113 – code V

	NX1 & NX2	NX3, NX4, NX6 & NX8
Model	N/A	ECN 1113 (Heidenhain)
Type		Absolute single turn encoder
Parker part number		220165P0002
Line count		512 sine/cosine periods per revolution
Electrical interface		Endat2.2
Position values per revolution		8 192 (13 bits)
System accuracy		$\pm 60''$
Perating speed		12 000 rpm
Power Supply		3.6VDC to 14VDC 85mA @ 5VDC
Current consumption (without load)		
Cutoff frequency – 3 dB		≥ 190 kHz typical
Operating temperature range		-40°C to +115 °C

3.9.7. Endat encoder multiturn ECN1125 – code W

	NX1 & NX2	NX3, NX4, NX6 & NX8
Model	N/A	ECN 1125 (Heidenhain)
Type		Absolute multi turn encoder
Parker part number		220165P0001
Line count		512 sine/cosine periods per revolution
Electrical interface		Endat2.2
Position values per revolution		8 192 (13 bits)
Revolutions		4 096
System accuracy		± 60"
Perating speed		12 000 rpm
Power Supply Current consumption (without load)		3.6VDC to 14VDC 105mA @ 5VDC
Cutoff frequency – 3 dB		≥ 190kHz typical
Operating temperature range		-40°C to +115 °C



With unregulated power supply (AC890 PARKER drive for instance), the max cable length is **65m** with 0.25mm² power supply wire due to the voltage drop into the cable itself.

Maximum Endat cable length

Please refer to the following curve to calculate the max cable length depending on the clock frequency

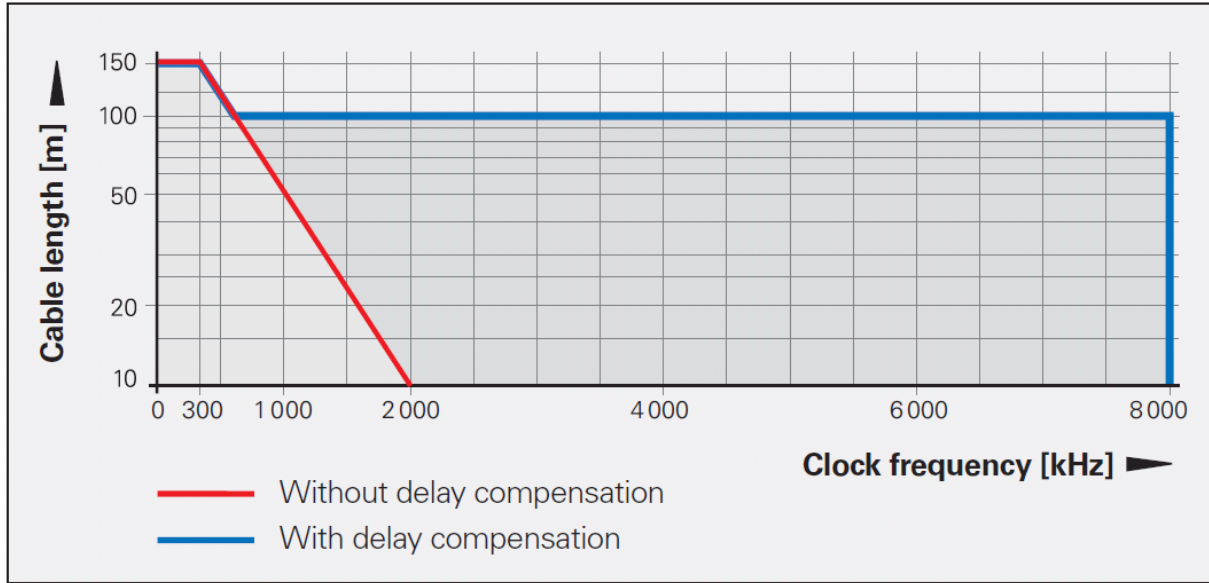

AC890 PARKER Wiring – EnDat encoder

From Heidenhain

Data (measured values or parameters) can be transferred bidirectionally between position encoders and subsequent electronics with transceiver components in accordance with RS-485 (differential signals), in synchronism with the clock signal produced by the subsequent electronics.

Dimensioning

IC₁ = RS 485 differential line receiver and driver

C₃ = 330 pF

Z₀ = 120 Ω

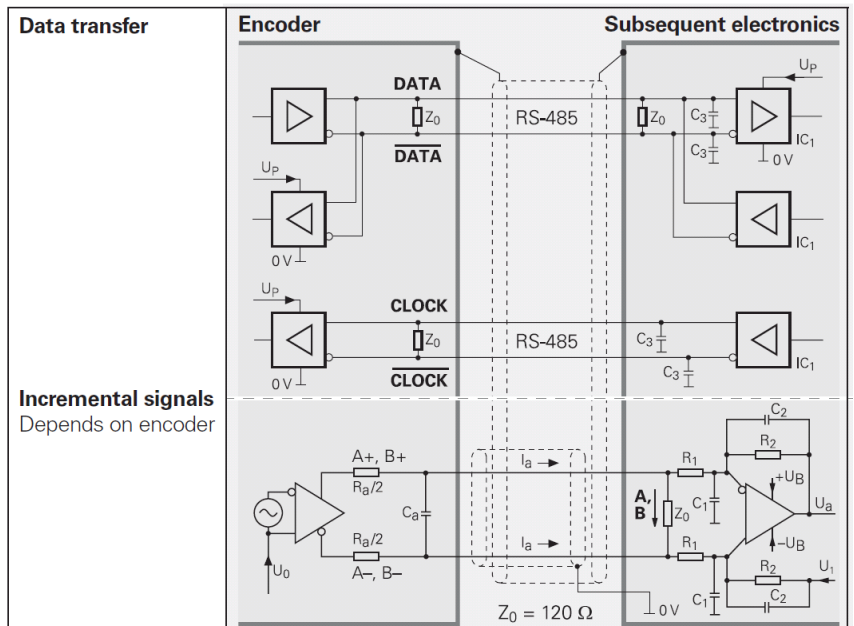



**3.9.8. Incremental encoder - Commuted lines 10 poles – 2048pulses
– code X (On request)**

	NX1, NX2, NX3, NX4, NX6 & NX8
Model	F10 (Hengstler)
Type	Incremental encoder with 10 pole commutation signals
Parker part number	220167P0003
Line count	2048 pulses per revolution
Electrical interface	Line driver 26LS31
System accuracy	Incremental signals $\pm 2.5'$ commutation signals $\pm 6'$
Perating speed	5 000 rpm
Power Supply Current consumption (without load)	5VDC $\pm 10\%$ 100mA
Max pulse frequency	300 kHz
Operating temperature range	0°C to +120 °C



3.9.9. Cables

To connect NX motor in connector version to PARKER drive : AC890, COMPAX3 or SLVD, you can use complete cable with part number on the tabs below.

The "xxx" in the part number must be replaced by the length in meter.

Ex : for 20m cable, "xxx" = 020.

3.9.9.1. Signal cable

Feedback Sensor	Cable reference for AC890	Cable reference for COMPAX3	Cable reference for SLVD	Cable reference for 637/638
Resolver for NX1	CS4UA1F4R0xxx	CC3UA1F4R0xxx	CS5UA1F4R0xxx	CS2UA1F4R0xxx
Resolver for NX2 to NX8	CS4UA1F1R0xxx	CC3UA1F1R0xxx	CS5UA1F1R0xxx	CS1UA1F1R0xxx
Hiperface encoder	N/A	CC3UR1F1R0xxx	CS5UR1F1R0xxx	CS2UR1F1R0xxx
EnDat Encoder	CS4UV1F3R0xxx	CC3UV1F3R0xxx	CS5UV1F3R0xxx	N/A

For other drive, you can assembly cable and plug by soldering with part number on the tab below:

Feedback Sensor	Cable reference	Plug reference
Resolver for NX1	6537P0047	220132R6620
Resolver for NX2 to NX8	6537P0047	220065R4621
Hiperface Encoder	6537P0048	220065R4621
EnDat Encoder	6537P0055	220132R4641



3.9.9.2. Power cable with or without brake

Motor size	Cable reference for AC890	Cable reference for COMPAX3	Cable reference for SLVD	Cable reference for 637/638
NX1	CS4UP0F4R0xxx	CC3UP0F4R0xxx	CS5UP0F4R0xxx	CS2UP0F4R0xxx
Current ≤ 12Amps	CS4UP1F1R0xxx	CC3UP1F1R0xxx	CS5UP1F1R0xxx	CS2UP1F1R0xxx
Current ≤ 30Amps	CS4UP2F1R0xxx	CC3UP2F1R0xxx	CS5UP2F1R0xxx	CS2UP2F1R0xxx

For other drive, you can assembly cable and plug by soldering with part number on the tab below:

Feedback Sensor	Cable reference	Plug reference
NX1	6537P0054	220132R6610
Current ≤ 12Amps	6537P0049	220065R1610
Current ≤ 30Amps	6537P0050	220065R1610

3.9.9.1. Power cable with or without brake and thermal sensor

Motor size	Cable reference for AC890	Cable reference for COMPAX3	Cable reference for SLVD	Cable reference for 637/638
Current ≤ 12Amps	CS4UQ1F1R0xxx	CC3UQ1F1R0xxx	CS5UQ1F1R0xxx	CS2UQ1F1R0xxx
Current ≤ 30Amps	CS4UQ2F1R0xxx	CC3UQ2F1R0xxx	CS5UQ2F1R0xxx	CS2UQ2F1R0xxx

For other drive, you can assembly cable and plug by soldering with part number on the tab below:

Feedback Sensor	Cable reference	Plug reference
Current ≤ 12Amps	6537P0043	220065R1610
Current ≤ 30Amps	6537P0046	220065R1610

3.10. Brake option

	<p>Caution: The holding brake is used to completely immobilize the servomotor under load. It is not designed to be used for repeated dynamic braking ; dynamic braking must only be used in the case of an emergency stop and with a limited occurrence depending on the load inertia and speed.</p>
--	---

The standard brake power supply is 24 Vcc DC \pm 10%.

Follow the polarity and the permissible voltage, and use shielded cables.

A 220 μ F capacitor avoids untimely braking if the 24 V voltage is disturbed by the external relay. Check the voltage value once this capacitor has been fitted. The RC network (220 Ω , 0.1 μ F) is needed to eliminate interference produced by the brake coil.

Position the contactor in the DC circuit to reduce brake response times. Follow the connection instructions taking the brake polarisation into account.

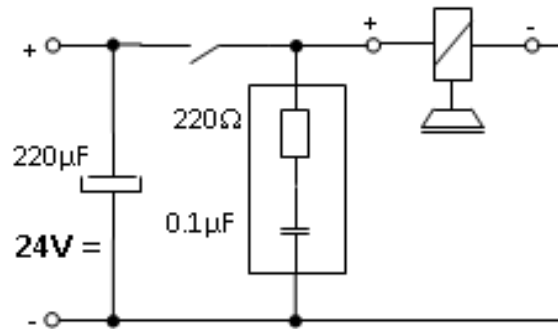

Motor	Static torque @20°C (N.m)	Static torque @100°C (N.m)	Power (W)	Engaging time (braking) (ms)	Disengaging time (Unbraking) (ms)	Extra Inertia (Kg.m ² .10 ⁻⁵)	Angular backlash (°)
NX1	0.4		6	27	13	0.1	0
NX2	1		8	14	28	1.2	0
NX3	2	1.8	11	13	25	0.68	0
NX4	5.5	4	12	17	35	1.8	0
NX6	12	8	18	28	40	5.4	0
NX8	36	32	26	45	100	55.6	0

Table with typical values

4. COMMISSIONING, USE AND MAINTENANCE

4.1. Instructions for commissioning, use and maintenance

4.1.1. Equipment delivery

All servomotors are strictly controlled during manufacturing, before shipping. While receiving it, it is necessary to verify motor condition and if it has not been damaged in transit. Remove it carefully from its packaging. Verify that the data written on the label are the same as the ones on the acknowledgement of order, and that all documents or needed accessories for user are present in the packaging.

	<p><u>Warning:</u> In case of damaged material during the transport, the recipient must immediately make reservations to the carrier through a registered mail within 24 h..</p>
--	---

4.1.2. Handling

Servomotors are equipped with two lifting rings intended for handling.

	<p><u>Caution:</u> Use only servomotors lifting rings, if present, or slings to handle the motor. Do not handle the motor with the help of electrical cables, connectors and water inputs/outputs, or use any other inappropriate method.</p>
--	---

The drawings below show the correct handling procedure.

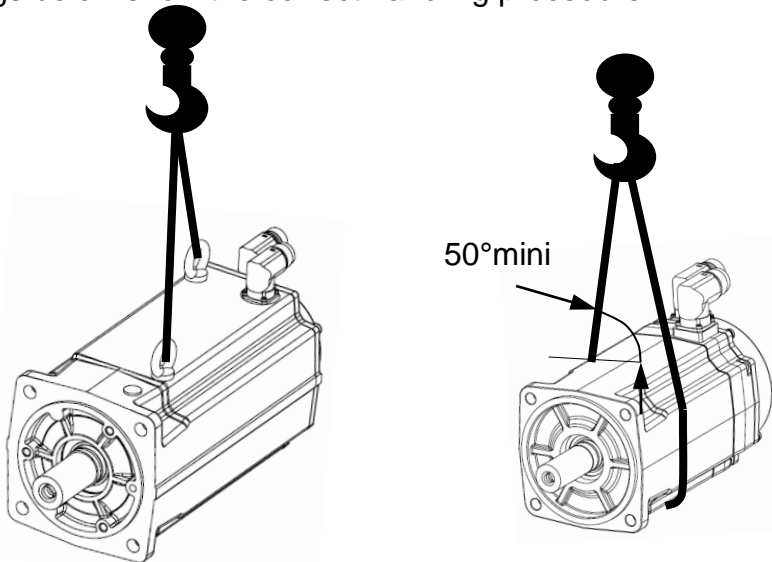

	<p><u>DANGER:</u> Choose the correct slings for the motor weight. The two slings must be the same length and a minimum angle of 50° has to be respected between the motor axis and the slings.</p>
--	--

4.1.3. Storage

Before being mounted, the motor has to be stored in a dry place, without rapid or important temperature variations in order to avoid condensation.

During storage, the ambient temperature must be kept between -20 and +60°C.

If the torque motor has to be stored for a long time, verify that the shaft end, feet and the flange are coated with corrosion proof product.

After a long storage duration (more than 3 month), run the motor at low speed in both directions, in order to blend the bearing grease spreading.

The motor is delivered with caps for the water inlet and outlet to protect the cooling circuit. Keep them on place until the motor commissioning.

4.2. Installation

4.2.1. Mounting

Foundation must be even, sufficiently rigid and shall be dimensioned in order to avoid vibrations due to resonance. Before bolting the motor, the foundation surface must be cleaned and checked in order to detect any excessive height difference between the motor locations. The surface variation shall not exceed 0,1 mm.

	<p><u>Caution:</u> The user bears the entire responsibility for the preparation of the foundation.</p>
--	--

The table below gives the average tightening torques required regarding the fixing screw diameter. These values are valid for both motor's feet and flange bolting.

Screw diameter	Tightening torque	Screw diameter	Tightening torque
M2 x 0.35	0.35 N.m	M9 x 1.25	31 N.m
M2.5 x 0.4	0.6 N.m	M10 x 1.5	40 N.m
M3 x 0.5	1.1 N.m	M11 x 1.5	56 N.m
M3.5 x 0.6	1.7 N.m	M12 x 1.75	70 N.m
M4 x 0.7	2.5 N.m	M14 x 2	111 N.m
M5 x 0.8	5 N.m	M16 x 2	167 N.m
M6 x1	8.5 N.m	M18 x 2.5	228 N.m
M7 x 1	14 N.m	M20 x 2.5	329 N.m
M8 x 1.25	20 N.m	M22 x 2.5	437 N.m
		M24 x 3	564 N.m

	<p><u>Warning:</u> After 15 days, check all tightening torques on all screw and nuts.</p>
---	---

4.2.2. Preparation

Once the motor is installed, it must be possible to access the wiring, and read the manufacturer's plate. Air must be able to circulate around the motor for cooling purposes.

Clean the shaft using a cloth soaked in white spirit or alcohol. Pay attention that the cleaning solution does not get on to the bearings.

The motor must be in a horizontal position during cleaning or running.

	<p><u>Caution:</u> Do not step on the motor, the connector or the terminal box</p>
	<p><u>Caution:</u> Always bear in mind that some parts of the surface of the motor can reach temperatures exceeding 100°C</p>

4.2.3. Mechanical installation

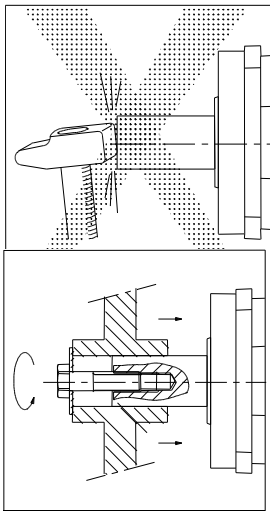





The operational life of torque motor bearings largely depends on the care and attention given to this operation.

- Carefully check the alignment of the motor shaft with that of the machine to be driven thus avoiding vibration, irregular rotation or putting too much strain on the shaft.
- Prohibit any impact on the shaft and avoid press fittings which could mark the bearing tracks. If press fitting cannot be avoided, it is advisable to immobilize the shaft in motion; this solution is nevertheless dangerous as it puts the encoder at risk.
- In the event that the front bearing block is sealed by a lip seal which rubs on the rotating section, we recommend that you lubricate the seal with grease thus prolonging its operational life.

	<p>We cannot be held responsible for wear on the drive shaft resulting from excessive strain.</p>
--	---

4.3. Electrical connections





	<p><u>Danger:</u> Check that the power to the electrical cabinet is off prior to making any connections.</p>
	<p><u>Caution:</u> The wiring must comply with the drive commissioning manual and with recommended cables.</p>
	<p><u>Danger:</u> The motor must be earthed by connecting to an unpainted section of the motor.</p>
	<p><u>Caution:</u> After 15 days, check all tightening torques on cable connection.</p>

4.3.1. Cable connection

Please, read §3.7 "Electrical connection" to have information about cable connection

A lot of information are already available in the drive documentations.

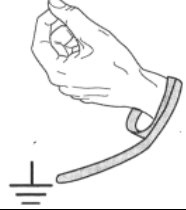
4.3.2. Encoder cable handling

	<p><u>Danger:</u> before any intervention the drive must be stopped in accordance with the procedure.</p>
	<p><u>Caution:</u> It is forbidden to disconnect the Encoder cable under voltage (high risk of damage and sensor destruction).</p>
	<p><u>Warning:</u> Always wear an antistatic wrist strap during encoder handling.</p>
	<p><u>Warning:</u> Do not touch encoder contacts (risk of damage due to electrostatic discharges ESD).</p>

4.4. Maintenance Operations

4.4.1. Summary maintenance operations

	<p>Generality <u>DANGER:</u> The installation, commission and maintenance operations must be performed by qualified personnel, in conjunction with this documentation.</p> <p>The qualified personnel must know the safety (C18510 authorization, standard VDE 0105 or IEC 0364) and local regulations.</p> <p>They must be authorized to install, commission and operate in accordance with established practices and standards.</p> <p>Please contact PARKER for technical assistance.</p>
---	--

	<p><u>Danger:</u> before any intervention the motor must be disconnected from the power supply.</p> <p>Due to the permanent magnets, a voltage is generated at the terminals when the motor shaft is turned</p>
---	---

Operation	Periodicity
Clean the motor	Every year
Motor inspection (vibration changes, temperature changes, tightening torques on all screws)	Every year
Bearing replacement	Every 20 000h
No water condensation checking for water cooling version	Every year
Cooling water quality inspection for water cooling version	Every year



4.5. Troubleshooting

Some symptoms and their possible causes are listed below. This list is not comprehensive. Whenever an operating incident occurs, consult the relevant servo drive installation instructions (the troubleshooting display indications will help you in your investigation) or contact us at: <http://www.parker.com/eme/repairservice>.

You note that the motor does not turn by hand when the motor is not connected to the drive.	<ul style="list-style-type: none"> • Check there is no mechanical blockage or if the motor terminals are not short-circuited.
You have difficulty starting the motor or making it run	<ul style="list-style-type: none"> • If there is a thermal protector, check it and its connection and how it is set in the drive. • Check the servomotor insulation (in doubt, measure when the motor is hot and cold). <p>The minimum insulation resistance measured under 50VDC max is 50 MΩ :</p> <ul style="list-style-type: none"> - Between phase wire and housing, - Between thermal protector and housing, - Between resolver winding and housing.
You find that the motor speed is drifting	<ul style="list-style-type: none"> • Adjust the offset of the servo drive.
You notice that the motor is racing	<ul style="list-style-type: none"> • Check the speed set-point of the servo drive. • Check you are well and truly in speed regulation (and not in torque regulation). • Check the encoder setting
You notice vibrations	<ul style="list-style-type: none"> • Check the encoder and tachometer connections, the earth connections (carefully) and the earthing of the earth wire, the setting of the servo drive speed loop, tachometer screening and filtering. • Check the stability of the secondary voltages. • Check the rigidity of the frame and motor support.
You think the motor is becoming unusually hot	<ul style="list-style-type: none"> • It may be overloaded or the rotation speed is too low : check the current and the operating cycle of the torque motor • Friction in the machine may be too high : <ul style="list-style-type: none"> - Test the motor current with and without a load. - Check the motor does not have thermal insulation. • Check the cooling circuit
You find that the motor is too noisy	<p>Several possible explanations :</p> <ul style="list-style-type: none"> • Unsatisfactory mechanical balancing • Defective coupling • Loosening of several pieces • Poor adjustment of the servo drive or the position loop : check rotation with the loop open.
The motor is warmer on its top	<p>Air bubbles can be stocked in the water cooling circuit. You need to purge the circuit or to double the water flow rate during 10 minutes to remove the air bubbles.</p>