

TITLE	SERVICE PARTS P2075 DESIGN SERIES II	DRAWING NUMBER	P2-075-0403	REVISION	A	STATUS	PR	SHEET 1 OF 7
-------	---	----------------	-------------	----------	---	--------	----	--------------

DRAWN BY	E. BOONE	DATE	15APR02	CHANGED BY	B. LARKIN	DATE	20MAY02	ECN NUMBER	133522
----------	----------	------	---------	------------	-----------	------	---------	------------	--------

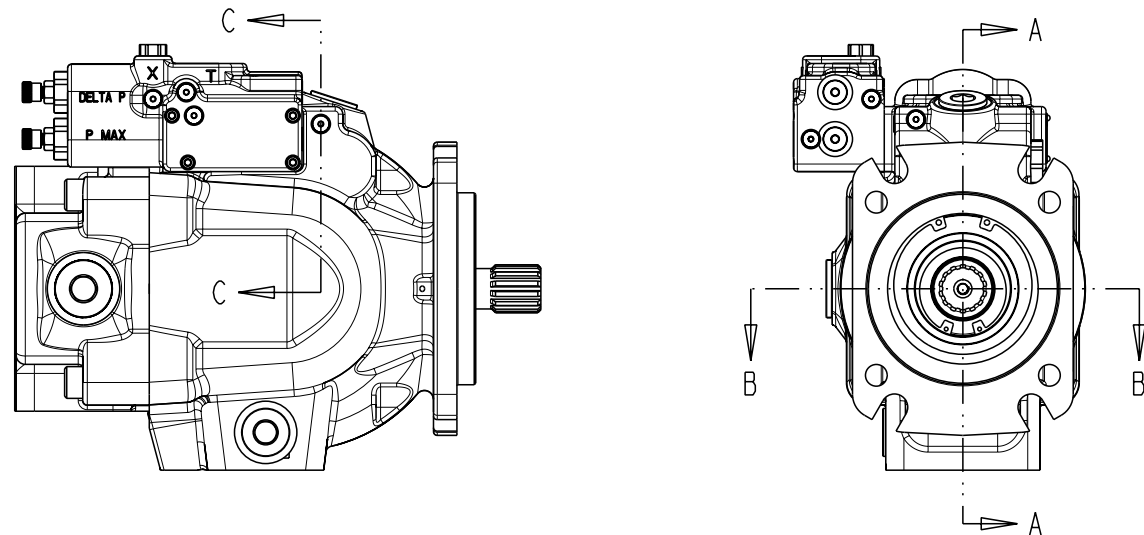

NOTES:
1 PUMP SHOWN IS A RIGHT HAND (CW) ROTATION PUMP. LEFT HAND (CCW) ROTATION PUMPS HAVE OUTLET GAUGE PORT REVERSED.

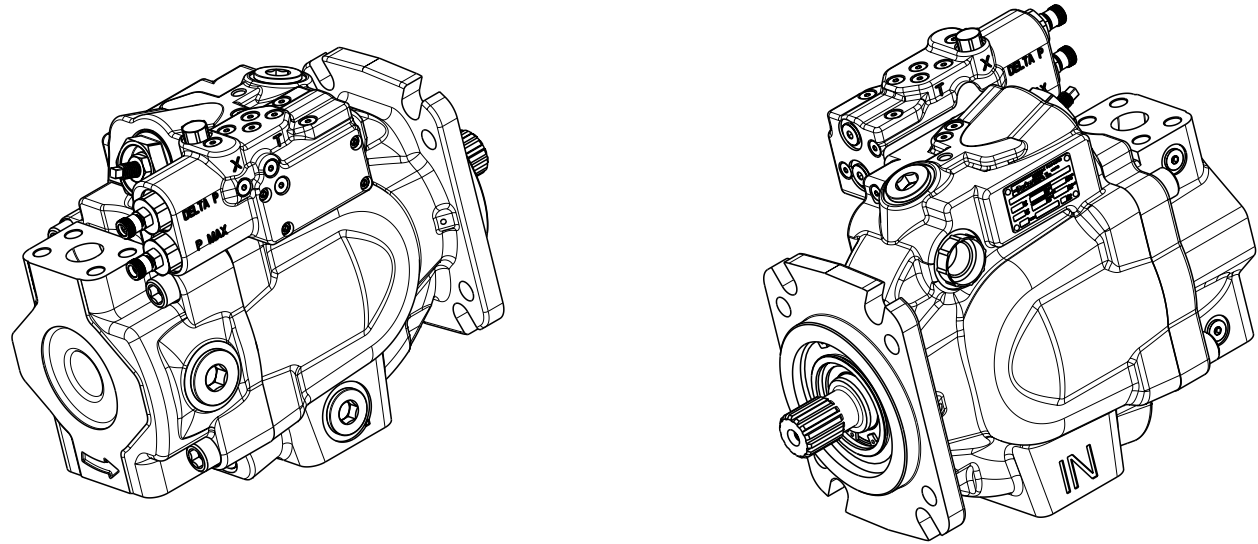
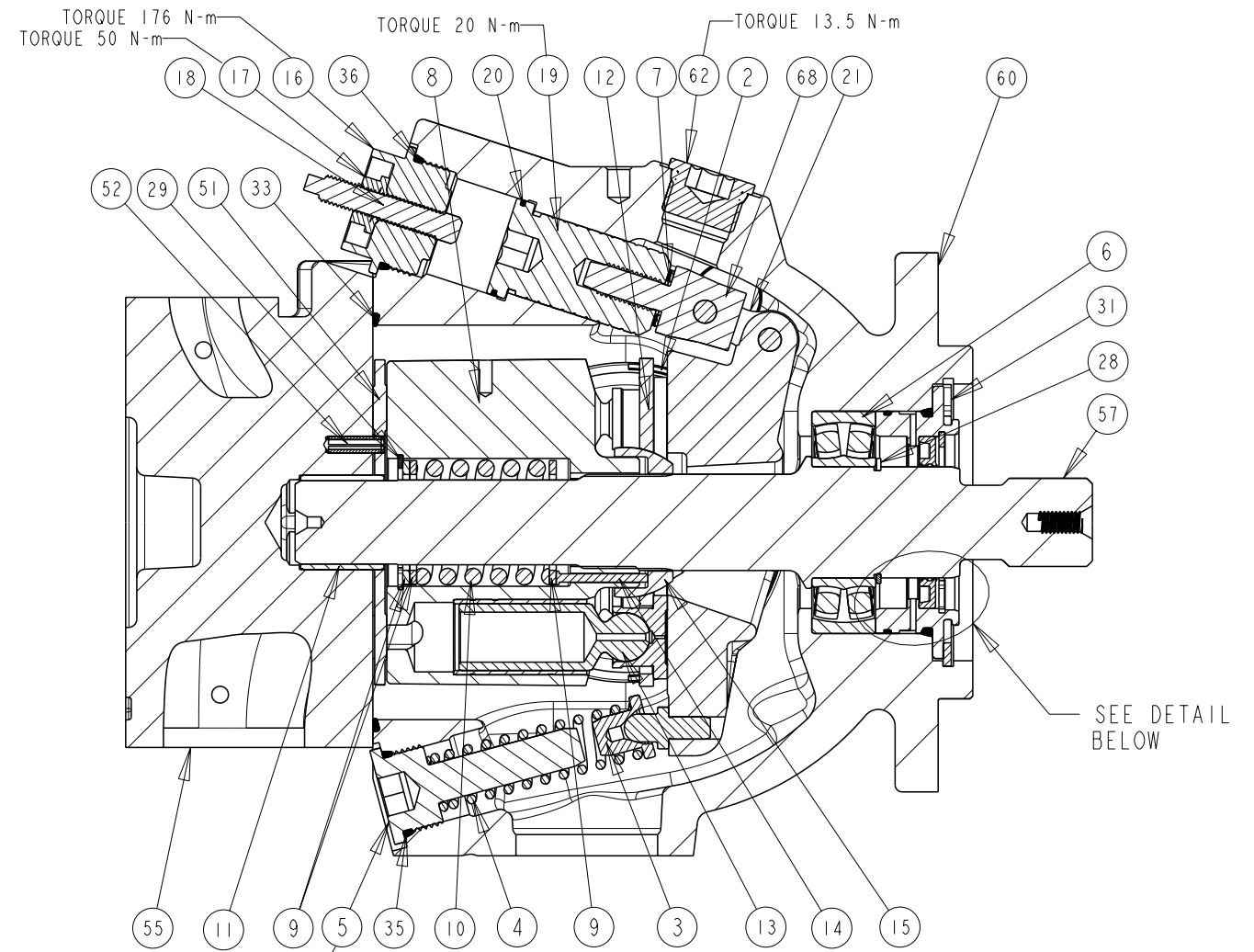

SECTION A-A
SCALE 2:5

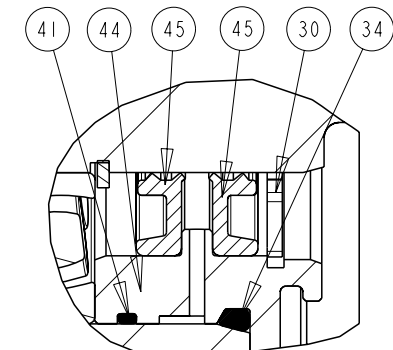

DUAL SHAFT SEAL ASSEMBLY
P2-075-0210-02
SECTION A-A
SCALE 1:1

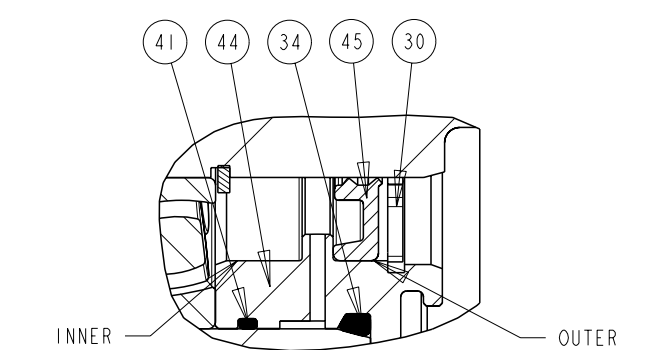

SINGLE SHAFT SEAL ASSEMBLY
P2-075-0210-01
SECTION A-A
SCALE 1:1

TITLE	DRAWING NUMBER	REVISION	STATUS	SHEET 2 OF 7
SERVICE PARTS P2075 DESIGN SERIES 11	P2-075-0403	A	PR	

DRAWN BY	DATE	CHANGED BY	DATE	ECN NUMBER
E. BOONE	15APR02	B. LARKIN	20MAY02	133522

(INSTALLED HEIGHT 4.5
OF ITEM #11) 4.0

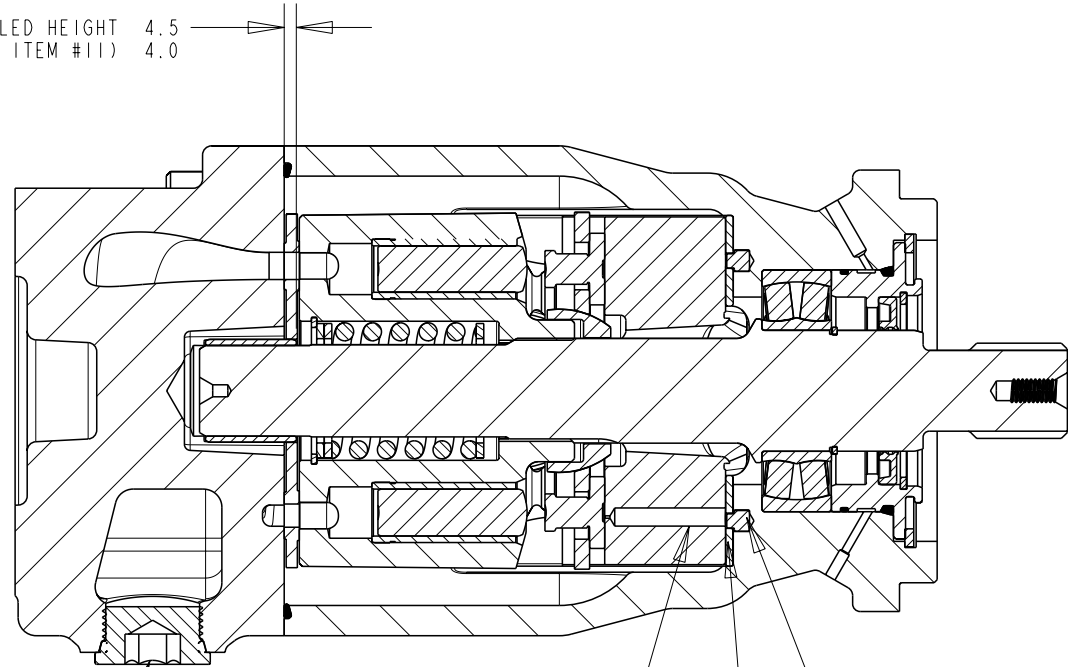

HOLE ON OPPOSITE SIDE
OF SHAFT FOR LEFT
HAND (CCW) MODELS

SECTION B-B
SCALE 2:5

108x16 (SAE)
788516-16 (6149)
TORQUE 230 N-m

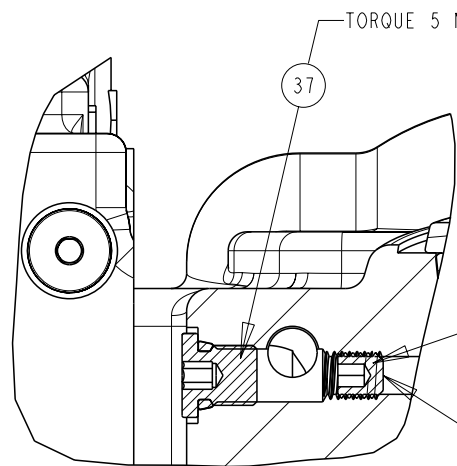

SECTION C-C
SCALE 1:1

M6X6 METRIC SET SCREW INSTALLED FOR ALL NON
TORQUE CONTROL OPTION PUMPS. REMOVE
SET SCREW FOR PUMPS USING TORQUE CONTROL
OPTION.

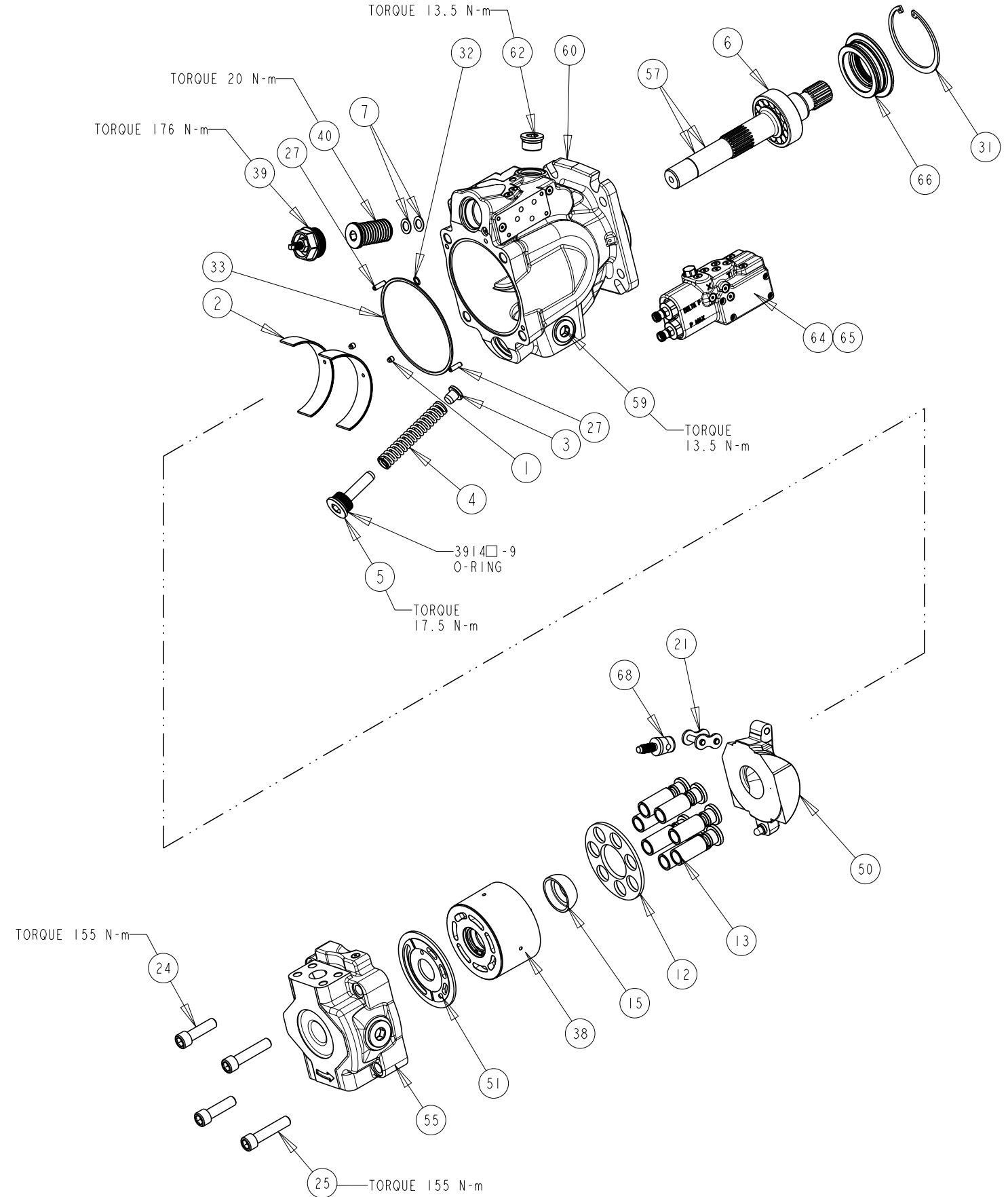

TITLE	DRAWING NUMBER	REVISION	STATUS	SHEET
SERVICE PARTS P2075 DESIGN SERIES 11	P2-075-0403	A	PR	3 OF 7

COMPENSATOR KITS

SINGLE SPOOL OPTIONS - ITEM 64

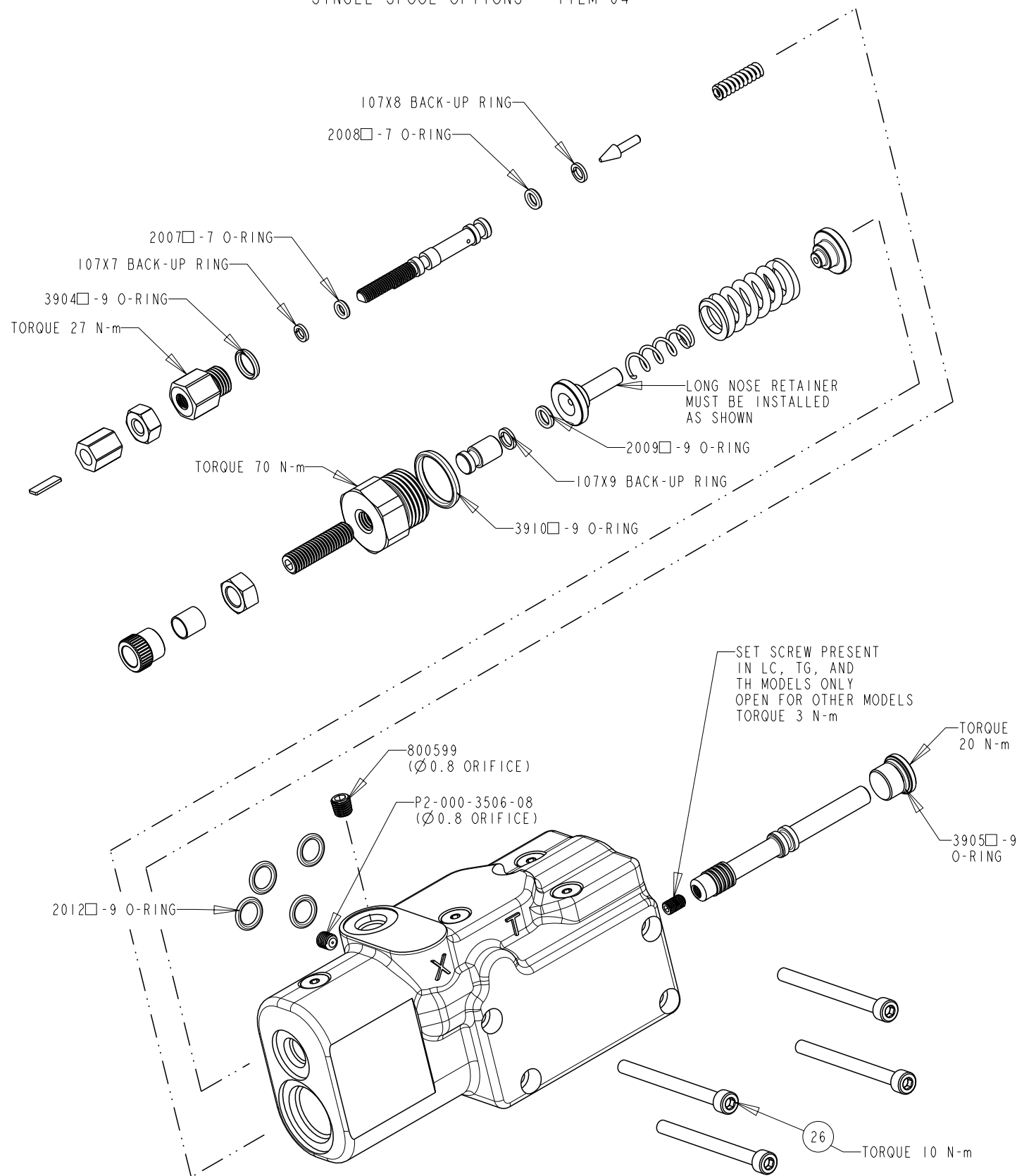

DRAWN BY	DATE	CHANGED BY	DATE	ECN NUMBER
E. BOONE	15APR02	B. LARKIN	20MAY02	133522

COMPENSATOR KITS

DUAL SPOOL OPTIONS - ITEM 65

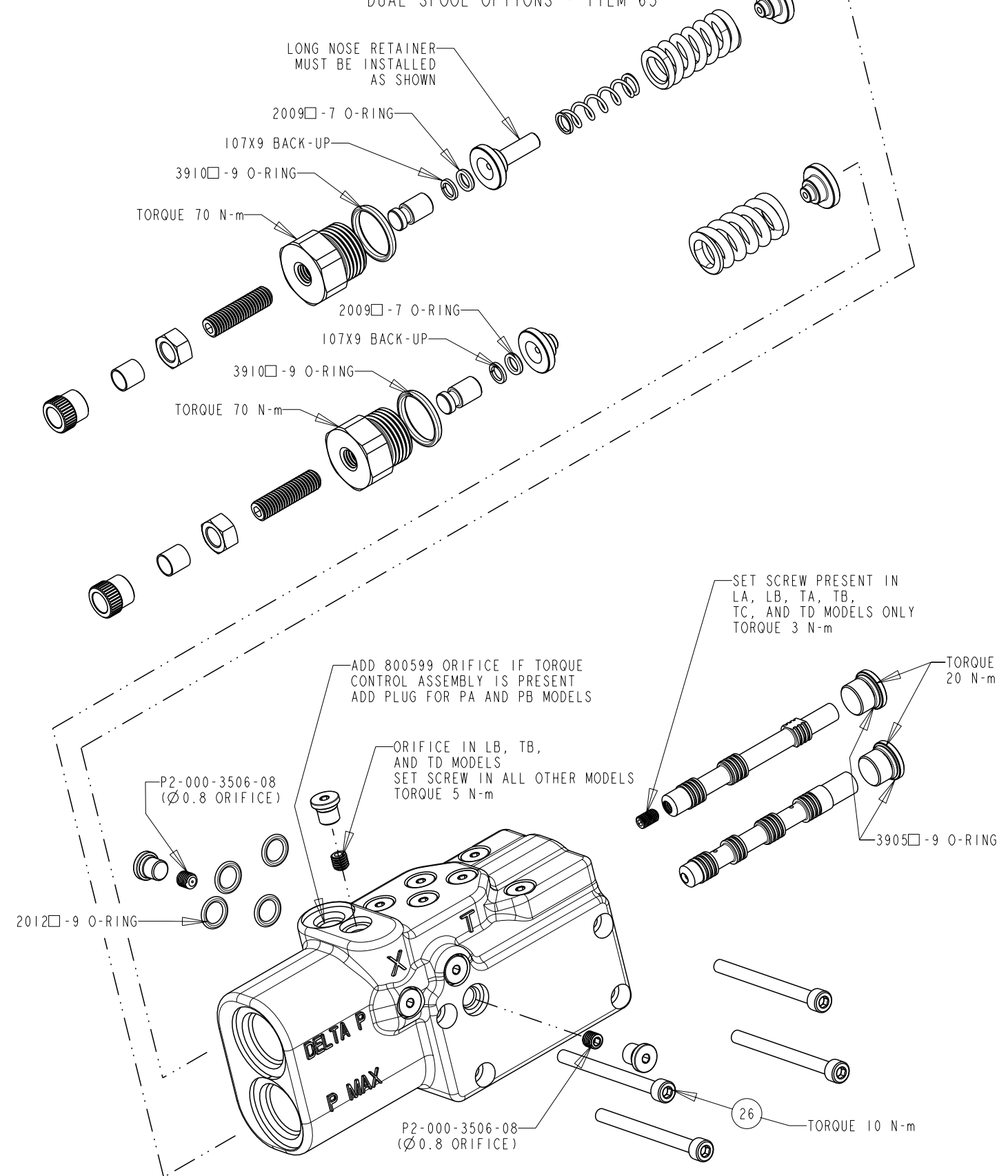

THRU DRIVE KITS

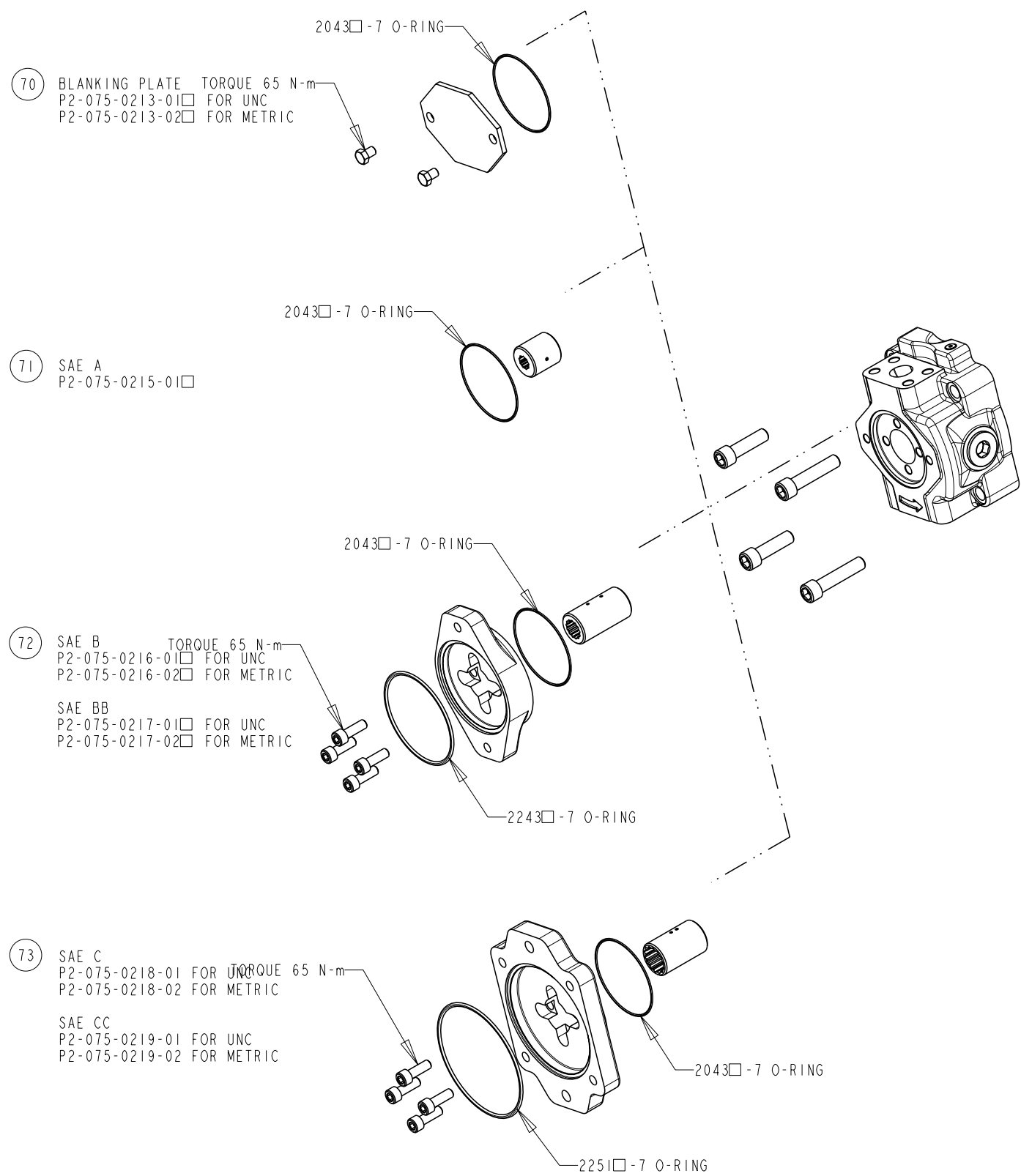

MAX VOLUME ASSEMBLY AND SERVO PISTON KIT

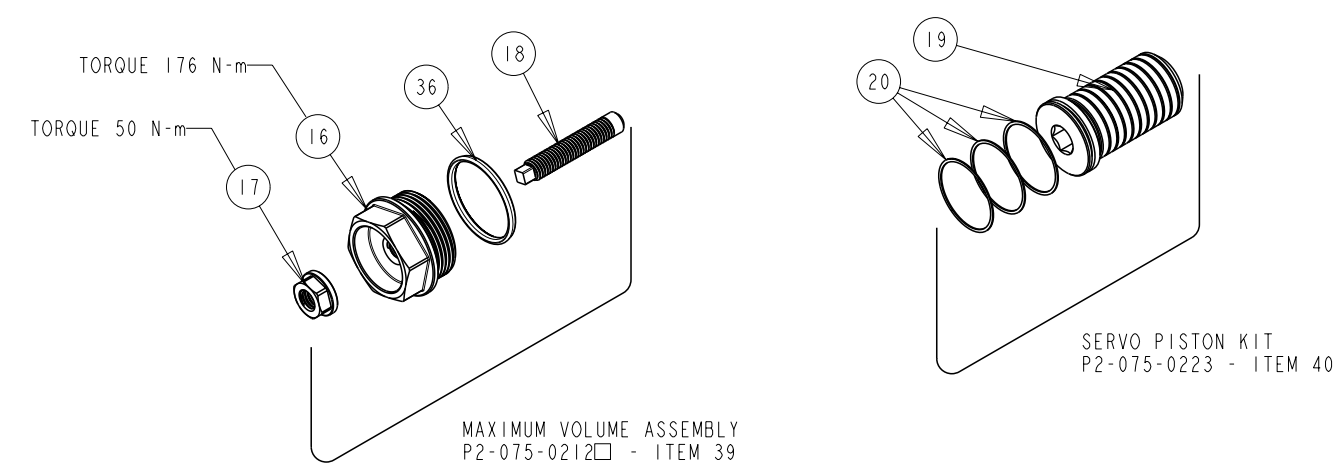

BARREL KIT AND ROTATION GROUP KIT

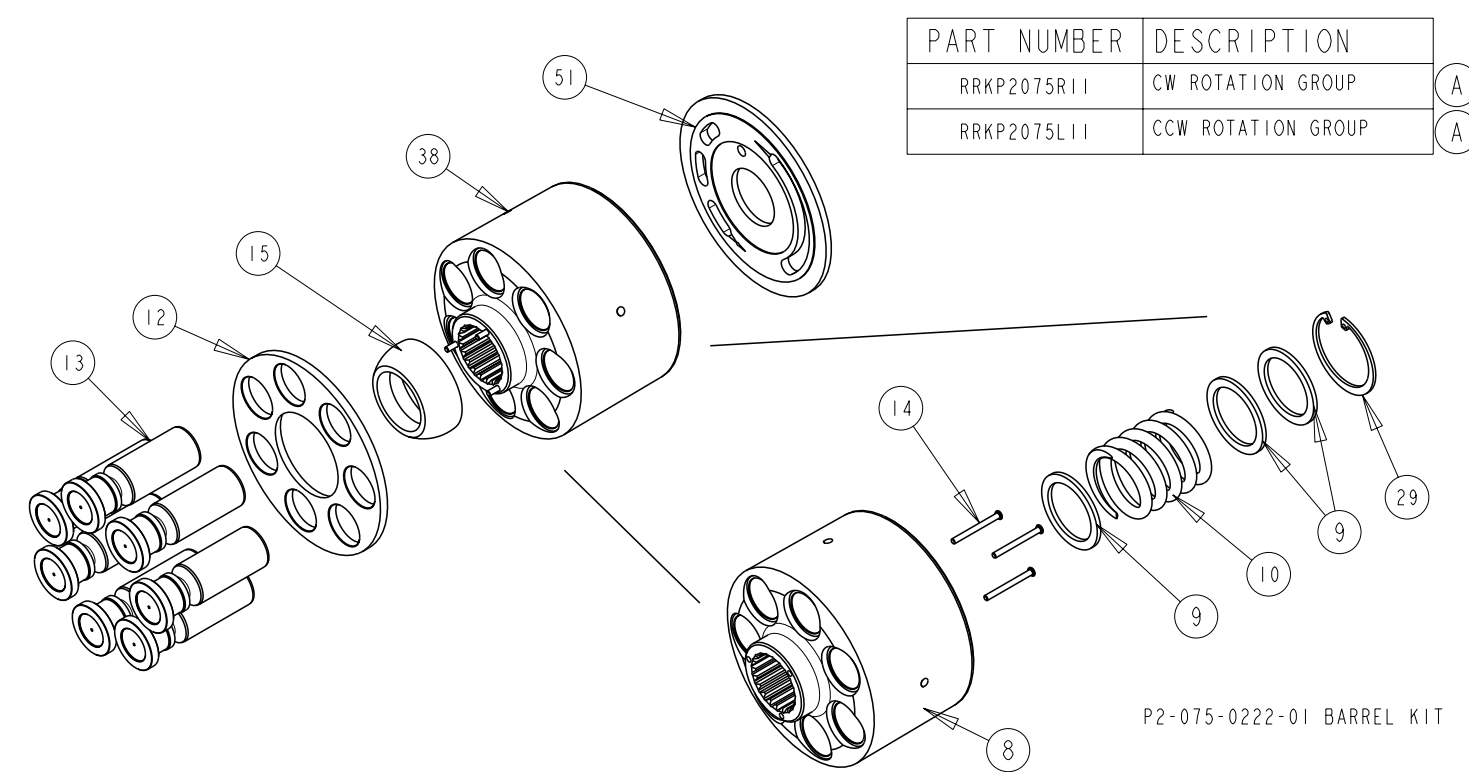

TITLE	DRAWING NUMBER	REVISION	STATUS	SHEET
SERVICE PARTS P2075 DESIGN SERIES II	P2-075-0403	A	PR	5 OF 7

SHAFT ASSEMBLY KITS ITEM 57

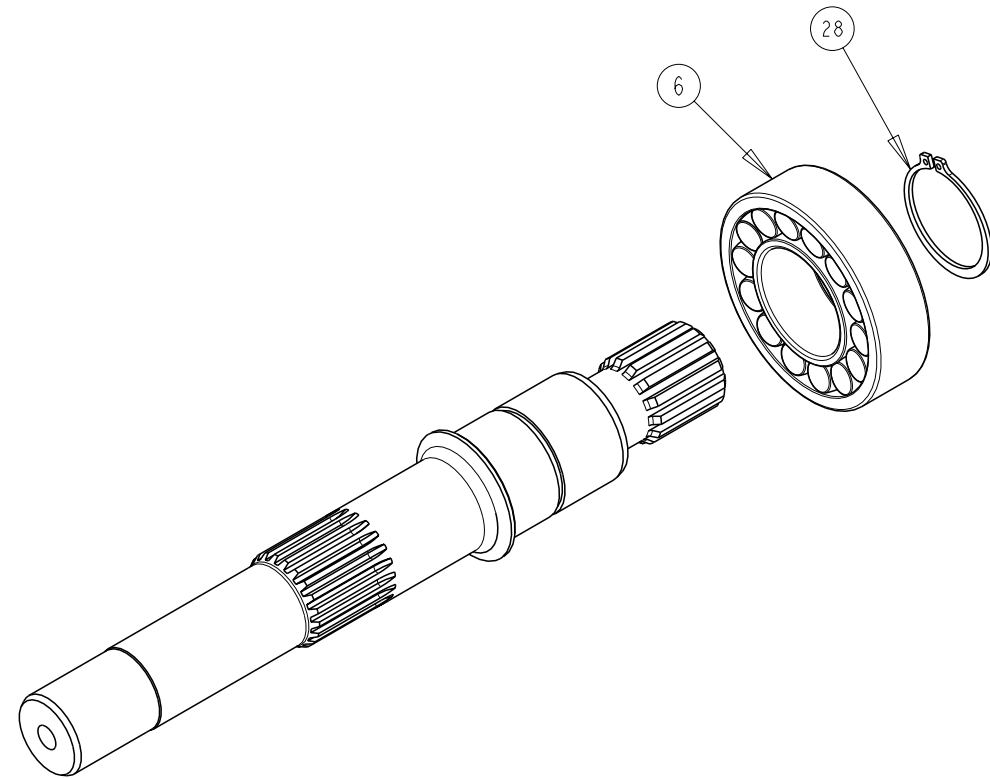

SHAFT ASSEMBLY INCLUDES, SHAFT, BEARING, AND SNAP RING

SHAFT ONLY	SHAFT ASSEMBLY	DESCRIPTION
P2-075-3512	P2-075-0225-35	C SPLINE
P2-075-3525	P2-075-0225-36	C SPLINE THRU
P2-075-3526	P2-075-0225-37	CC SPLINE
P2-075-3527	P2-075-0225-38	CC SPLINE THRU
P2-075-3532	P2-075-0225-45	C KEY
P2-075-3533	P2-075-0225-46	C KEY THRU
P2-075-3534	P2-075-0225-47	CC KEY
P2-075-3535	P2-075-0225-48	CC KEY THRU
P2-075-3542	P2-075-0225-55	C SPLINE NO UNDERCUT
P2-075-3520	P2-075-0225-56	C SPLINE THRU NO UNDERCUT
P2-075-3543	P2-075-0225-57	CC SPLINE NO UNDERCUT
P2-075-3544	P2-075-0225-58	CC SPLINE THRU NO UNDERCUT

DRAWN BY	DATE	CHANGED BY	DATE	ECN NUMBER
E. BOONE	15APR02	B. LARKIN	20MAY02	133522

COVER ASSEMBLY KITS ITEM 55

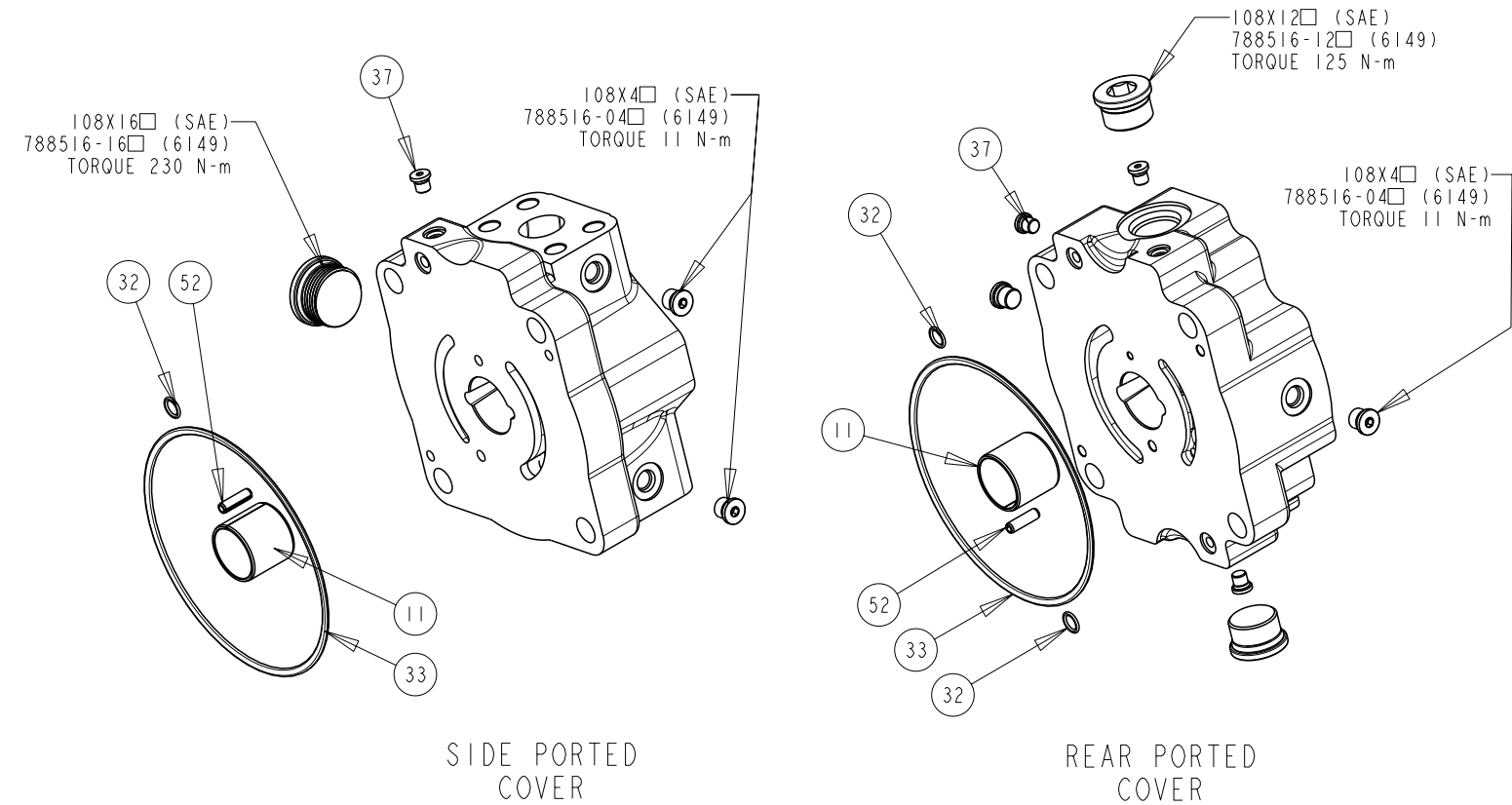

SIDE PORTED
COVER

REAR PORTED
COVER

COVER ONLY	COVER ASSY	DESCRIPTION
P2-075-1013-01	P2-075-0226-01	SIDE PORTED, CCW, UNC
P2-075-1013-02	P2-075-0226-02	SIDE PORTED, CCW, UNC, THRU
P2-075-1013-03	P2-075-0226-03	SIDE PORTED, CCW, METRIC
P2-075-1013-04	P2-075-0226-04	SIDE PORTED, CCW, METRIC, THRU
P2-075-1014-01	P2-075-0226-05	SIDE PORTED, CW, UNC
P2-075-1014-02	P2-075-0226-06	SIDE PORTED, CW, UNC, THRU
P2-075-1014-03	P2-075-0226-07	SIDE PORTED, CW, METRIC
P2-075-1014-04	P2-075-0226-08	SIDE PORTED, CW, METRIC, THRU
P2-075-1017-01	P2-075-0226-17	REAR PORTED, CW, UNC
P2-075-1017-02	P2-075-0226-18	REAR PORTED, CW, METRIC
P2-075-1017-01	P2-075-0226-19	REAR PORTED, CCW, UNC
P2-075-1017-02	P2-075-0226-20	REAR PORTED, CCW, METRIC

TITLE	SERVICE PARTS P2075 DESIGN SERIES II	DRAWING NUMBER	P2-075-0403	REVISION	A	STATUS	PR	SHEET 6 OF 7
-------	---	----------------	-------------	----------	---	--------	----	--------------

DRAWN BY	E. BOONE	DATE	15APR02	CHANGED BY	B. LARKIN	DATE	20MAY02	ECN NUMBER	133522
----------	----------	------	---------	------------	-----------	------	---------	------------	--------

TORQUE CONTROL CARTRIDGE

P2-000-0803 - ITEM 63

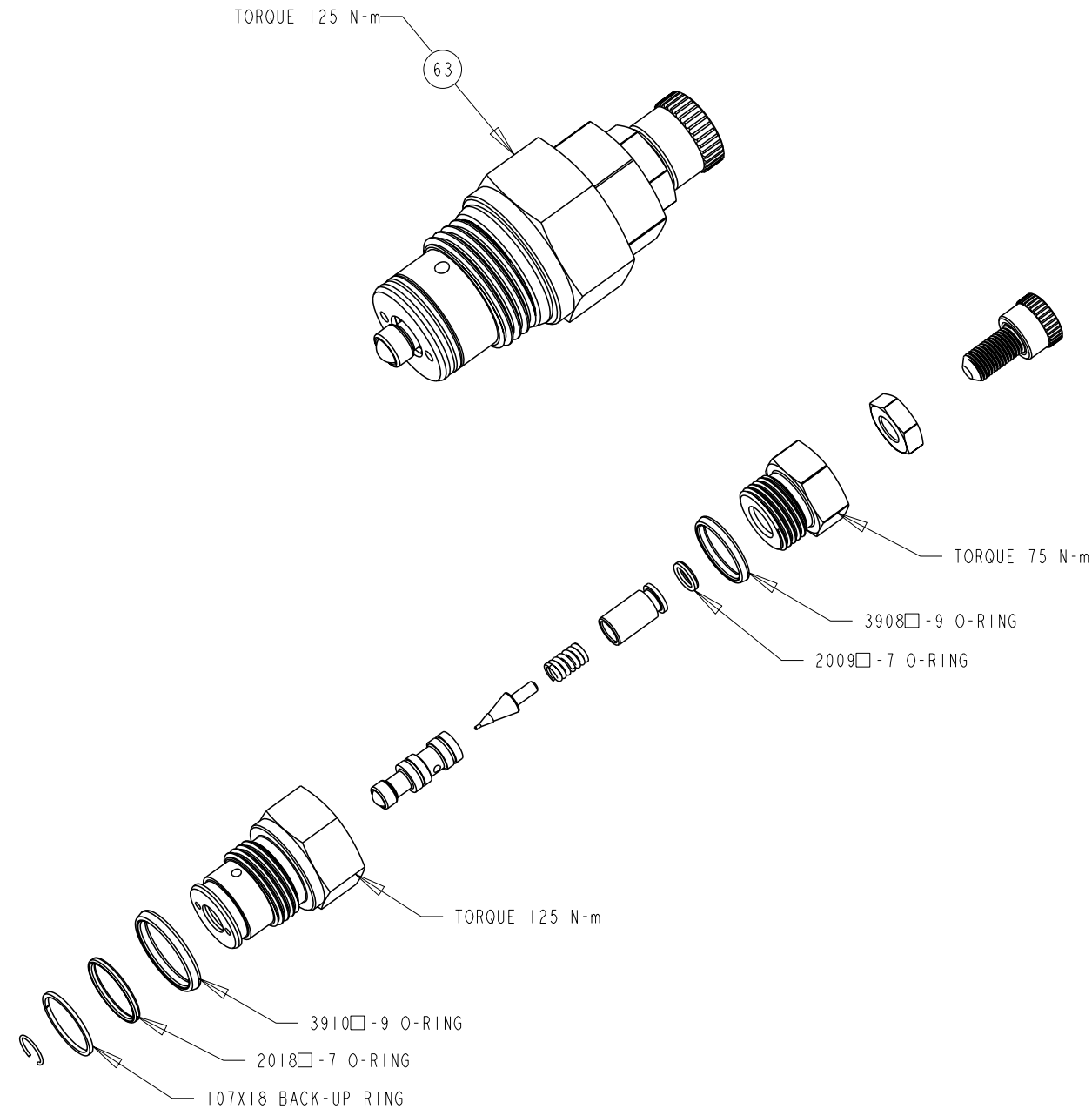

ASSEMBLY, DIS-ASSEMBLY AND REPAIR NOTES

DISASSEMBLY STEPS FOR ENTIRE PUMP

1. REMOVE COVER SCREWS AND COVER
2. REMOVE ROTATING GROUP
3. REMOVE SHAFT SEAL CARRIER
4. REMOVE SHAFT
5. REMOVE BIAS SPRING PLUG, SPRING AND RETAINER
6. REMOVE MAX. VOLUME ASSY
7. REMOVE SERVO PISTON ASSY.
NOTE NUMBER OF SPACING WASHERS (ITEM #7) BETWEEN SERVO PISTON AND LINK PISTON. RE-ASSEMBLY WITH SAME AMOUNT.
8. REMOVE SWASHPLATE ASSEMBLY

SHAFT SEAL REPLACEMENT

1. REMOVE SEAL CARRIER ONLY
2. REMOVE OLD SEAL
3. INSPECT SHAFT
4. IF SHAFT IS WORN INSTALL NEW SEAL IN INNER LOCATION FOR SINGLE SEAL APPLICATIONS (SEE SHEET 1).
REPLACE SHAFT FOR DUAL SEAL APPLICATIONS

