



# Modular electrical linear drives OSP-E

Operating Instructions

*ORIGA SYSTEM PLUS*

aerospace  
climate control  
electromechanical  
filtration  
fluid & gas handling  
hydraulics  
pneumatics  
process control  
sealing & shielding



ENGINEERING YOUR SUCCESS.

[www.comoso.com](http://www.comoso.com)



## Content

<b>1</b>	<b>Foreword to the Operating Instructions</b>	<b>4</b>
<b>2</b>	<b>Safety</b>	<b>5</b>
<b>3</b>	<b>Warranty</b>	<b>6</b>
<b>4</b>	<b>Transport and Assembly</b>	<b>6</b>
	4.1 Transport.....	6
	4.2 Interim storage .....	7
	4.3 Assembly .....	7
<b>5</b>	<b>Commissioning</b>	<b>7</b>
<b>6</b>	<b>After sales service</b>	<b>7</b>
<b>7</b>	<b>Belt drives OSP-E..BHD / OSP-E..BV / OSP-E..B</b>	<b>8</b>
	7.1 Technical data .....	8
	7.2 Structural arrangement and operating mode .....	12
	7.3 Maintenance / repair .....	15
<b>8</b>	<b>Spindle drives OSP-E..SB / OSP-E..ST / OSP-E..SBR / OSP-E..STR</b>	<b>24</b>
	8.1 Technical data .....	24
	8.2 Structural arrangement and operating mode .....	27
	8.3 Maintenance / repair .....	29
<b>9</b>	<b>Accessories</b>	<b>34</b>
	9.1 Multi-axle system .....	34
	9.2 Linear guides.....	34
	9.3 Mountings and sensors .....	34
	9.4 Couplingbox and coupling.....	34
	9.5 Synchronous belt drive with configuration capability.....	37
<b>10</b>	<b>Manufacturer's statement</b>	<b>39</b>
<b>11</b>	<b>Spare part lists</b>	<b>40</b>
	11.1 OSP-E..BHD (Recirculating ball bearing guide) .....	40
	11.2 OSP-E..BHD (Roller Guide).....	42
	11.3 OSP-E..BV.....	44
	11.4 OSP-E..B .....	46
	11.5 OSP-E..B (Bi-Parting version).....	48
	11.6 OSP-E..SB .....	50
	11.7 OSP-E..ST.....	52
	11.8 OSP-E..SB .....	54
	11.9 OSP-E..STR.....	55

## Operator's responsibilities

The operator/organisation in charge is responsible for:

- Compliance with EN 89/655 replaced by 2001/45EWG and its national implementation,
- Compliance with 89/392/EEC in the version 91/368/EEC and 93/44/EEC
- Compliance with the national regulations for working safety applicable.
- Using the OSP-E for the intended purpose only.
- Compliance with all rules and regulations of these Operating Instructions.

It is not permitted to start the OSP-E until it has been ascertained that the machine into which the unit has been assembled fully complies with the provisions of the EC Machines Directive .

## 1 Foreword to the Operating Instructions

The purpose of these Operating Instructions is to assist you in familiarising yourself with the OSP-E and to make use of the functions it has been designed for.

The Operating Instructions contain important advice so that you can use the OSP-E safely, reliably and economically. Observance of these Operating Instructions will help you to avoid danger, reduce repair costs and downtime as well as to increase reliability and the service life of the OSP-E.









These Operating Instructions need to be read and applied by all persons working with the OSP-E, including:

- operating the unit, including setup work, trouble shooting during the work sequence, removal of production waste, servicing, handling as well as removing waste of hazardous materials (operating and auxiliary materials);
- maintenance (preventive maintenance, inspection, repairs)

In addition to the Operating Instructions and the mandatory regulations for accident prevention and environmental protection applicable in the user country and at the location of deployment , the standard technical rules and regulations for safe and professional work shall also be observed.

### Explanation of symbols and instruction notes

Instruction notes marked with these symbols help to prevent physical injury and harm for persons. All users shall be informed of all such instruction notes.

Symbol	Explanation	Symbol	Explanation
	Attention: Safety-relevant passages of the Operating Instructions will indicate this symbol		Attention: Danger of lacerations
	Information: Symbol for tips and instructions to facilitate working with the machine and to prevent damage		Important: Wear protective goggles
	Attention: Falling loads		Important: Wear protective gloves
	Attention: Danger resulting from crushing		Note: Accessories available

### Copyright

Parker-Origa GmbH has the copyright to these Operating. Instructions Copyright 2008®.

No part of these Operating Instructions may be copied or distributed or used in any way or divulged to third parties for competitive purposes. Any infringement may result in legal action.

### The identification plate

This identification plate is located at the OSP-E in the groove of the cylinder barrel.

### Product observation

It is our aim to have safe and reliable products that represent state-of-the-art technology. For this reason, we constantly monitor our products even after delivery. Please inform us immediately of any repeating faults or problems with the OSP-E.

## 2 Safety

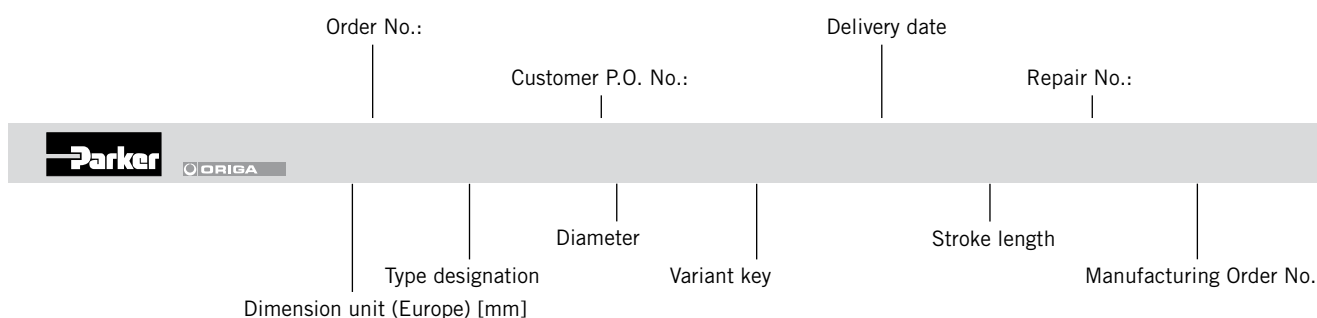

### Use in accordance with the design purpose

**We will only warrant the operating safety of the OSP-E if it is used in accordance with the design purpose.**

The following usage is in accordance with the design purpose:

- moving loads,
- applying force.

The OSP-E is powered by electric motors.

Also to be taken into account:

- The conditions as stated and stipulated in the order confirmation,
- the operating instructions

If the OSP-E is used for any other purposes, this constitutes a use not in accordance with the design purpose.

This may result in material damage and personal injury for which we cannot be held responsible or liable in any way. The user is entirely responsible for any risk arising from such a use.

### The Operating Personnel

The operator of the overall plant needs to ensure that only authorised and qualified specialised personnel are allowed to work with and at the OSP-E. Authorised personnel are trained specialised personnel of the user, the manufacturer and the service partner.

### Working with an awareness of safety

The contents of these Operating Instructions, particularly the chapter on "Safety Instructions" must be duly observed under all circumstances.

Before commencing work, all personnel assigned to work with the OSP-E must have read and thoroughly understood the Operating Instructions - and the chapter on Safety in particular. Doing so while at work is too late !! This also applies in particular to personnel working occasionally on the OSP-E, e.g., during set-up and maintenance.

At appropriate intervals, check the safety-awareness of the personnel at work with due observance of the Operating Instructions.

### The following is not permitted:

- carrying out independent modifications of the OSP-E,
- using working methods that impair the safety of the OSP-E.

### Observe at the OSP-E:

- All attached safety instructions

Maintain these instructions in a fully legible condition.

Observe also the manufacturer's instructions on lubricants, solvents and cleaning agents.

### Conversions and alterations

The linear drives shall not be modified in its construction and safety aspects, without the prior written approval of **Parker-Origa GmbH**. Any such modifications carried out without approval will rule out all liability on the part of **Parker-Origa GmbH**.

In principle, no safety and protection devices/equipment shall be dismantled or put out of operation.

When installing special attachments, the assembly regulations of the manufacturer shall be observed as required.

The following regulatory instruments must be observed as a matter of course:

- relevant rules and regulations for accident prevention,
- generally recognised safety regulations,
- EU-Directives and
- country-specific provisions.

## Spare parts

The use of original spare parts and accessories authorised by the manufacturer is an important aspect for your safety. The use of other parts may change the characteristics of the OSP-E.

We accept no liability for any consequences resulting from the use of such parts.

## 3 Warranty

We reserve the right to make alterations to these Operating Instructions as well as to technical details with reference to data and illustrations as contained in these Operating Instructions.

**Parker-Origa GmbH** issues no quality and durability guarantees or any guarantees for the suitability for certain purposes unless these are expressly agreed in writing.

Public statements, statements of quality or advertising are not statements of characteristics.

If the user wants to make a claim under the warranty, he needs to notify the fault immediately and describe it precisely in his statement of complaint. Under no circumstances is **Parker-Origa GmbH** responsible for damage to the product itself or for consequential damage caused by the product, as caused by incorrect and faulty handling of the product. Insofar as **Parker-Origa GmbH** is responsible for a fault,

**Parker-Origa GmbH** may, at its discretion, either repair/modify the product or replace the item with a new one.

All OSP-E are provided with an identification plate within the framework of ISO 9000, that is attached to an OSP-E. This identification plate shall not be removed or destroyed in any way.

A liability of Messrs **Parker-Origa GmbH** – irrespective of the legal reason – exists only in the event of intentional or gross negligence, culpable injury to life, body, health, in the event of deficiencies with malicious intent of deception or faults the absence of which has been expressly guaranteed.

Furthermore, the company is liable to the extent stipulated by the product liability law regarding personal injury or material damage on objects used privately. In the event of culpable violation of essential contractual obligations, **Parker-Origa GmbH** is liable also in the case of minor negligence, however, limited to the damage that could be foreseen under the contract.

Any other claims are ruled out.

No warranty shall apply in the event of non-observance of these Operating Instructions, the relevant legal provisions as well as further instructions of the supplier.

In particular, we are not responsible for stoppages caused by modifications by the customer or other persons. In such cases, we charge the normal repair costs. These are also charged for an inspection of the equipment where no fault can be found on the equipment.

This regulation also applies during the warranty period.

Users have no rights regarding the supply of previous equipment versions or regarding the upgrading of equipment to the current version.

## 4 Transport and Assembly

### 4.1 Transport

The linear drives OSP-E are high-precision equipment. Strong and abrupt jolts/bumps can damage the mechanical system or affect the functioning. In order to avoid damage during transport, the equipment is fixed in appropriate protective packaging.



#### Danger caused by falling load

Incorrect transport and assembly of the OSP-E can:

- endanger human life,
- result in material damage.

#### Transport of the packaged OSP-E with a crane or a forked-lift truck.

- Apply slinging as shown, and position the fork-lift truck as shown.

#### Transport of the OSP-E with a crane

- Apply slinging as shown.

#### Information



Transport damage and missing parts are to be reported immediately and in writing to the transport company or to Parker-Origa GmbH or to the delivery company.

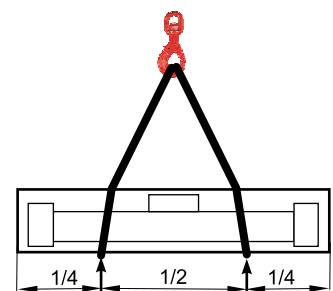
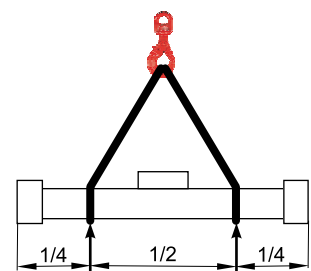

## 4.2 Interim storage

Where interim storage is involved, you must observe the following:

- dry, dust- and vibration-free storage,
- on a flat surface,
- outdoors under a suitable covering.



**You must avoid deflection (bending) of the OSP-E !**

## 4.3 Assembly

Before assembly, all transport devices must be removed and disposed of as required.

The assembly itself must be carried out in such a way that

- the applicable rules and regulations are observed as required,
- the OSP-E is installed without distortion or warping,
- all connections and operating parts are accessible,
- the company name is legible on the red cover strip.



**Any potential hazards that may exist between ORIGA products and customer's items of equipment must be eliminated by the user as required.**

### Notes for using the OSP-E

#### Mechanical



- Secure the payload only at the threaded holes on the driver and/or at the piston rod thread.
- Place the payload in such a way that the bending moments at the driver are below the values that are stated in the catalogue OSP-E.
- Use central supports for long drives.

#### Electrical

- Exact positioning of the load is effected by the control unit.
- Do not locate the sensor close to ferritic parts or to moving loads .
- Use the most favourable mounting slot on the circumference of the cylinder profile.

## 5 Commissioning

The linear drive can produce quick linear movements with high force. Failure to observe the safety regulations can cause bodily injury as a result of trapping, or damage as a result of collision with other plant parts.



### Danger of crushing

#### Inspect before start-up:

- The correct connection conditions, and
- that there nothing in the way of the moving load.

During the first start-up, check the function of proximity and/or limit switches. First, the linear drive should be allowed to run through the entire moving zone at low speed in order to detect any possible collision areas. These must be removed immediately.

## 6 After sales service

### Spare parts and after sales service addresses



Refer to the last page of these Operating Instructions

### Spare parts list

For the purposes of preventive maintenance for the linear drives, we offer seal kit sets, service packages and spare parts (refer to **Chapter 11**).

## 7 Belt drives OSP-E..BHD / OSP-E..BV / OSP-E..B

### 7.1 Technical data

#### 7.1.1 General



Detailed information on

- dimensions,
  - space requirement,
  - and weights
- are shown in the **OSP-E catalogue**.

The following applies for all linear drives of the product series OSP-E with belt drive:

- Temperature range: -30°C to +80°C.
- Installation location: BHD, B = any  
BV = vertical

**We reserve the right to make technical alterations !**

#### 7.1.2 OSP-E..BHD

**BHDII: Linear drive with toothed belt and integrated recirculating linear ball bearing guide.**

Performance overview						
Characteristic	Unit	Description				
Series		<b>OSP-E20BHD</b>	<b>OSP-E25BHD</b>	<b>OSP-E32BHD</b>	<b>OSP-E50BHD</b>	
Max. speed	[m/s]	3.0	5.0	5.0	5.0	
Linear motion per revolution of the drive shaft with integrated gear	[mm]	125	180	240	350	
	[mm]	-	220	280	360	
Max. speed of the drive shaft	[min <sup>-1</sup> ]	2 000	1 700	1 250	860	
Maximum effective action force F <sub>A</sub> with reference to the drive torque	< 1 m/s	[N]	550	1 070	1 870	3 120
	1 - 3 m/s	[N]	450	890	1 560	2 660
	> 3-10 m/s	[N]	-	550	1 030	1 940
No-load torque	[Nm]	0.6	1.2	2.2	3.2	
Max. acceleration /deceleration	[m/s <sup>2</sup> ]	50	50	50	50	
Repeatability	[mm/m]	± 0.05	± 0.05	± 0.05	± 0.05	
Max. standard stroke length	[mm]	5760	5700	5600	5500	
Tightening torque clamping hub	[Nm]	4,8	9,5	17	40	

Max. permissible torque on the drive shaft															
Speed / stroke															
OSP-E20BHD				OSP-E25BHD				OSP-E32BHD				OSP-E50BHD			
Speed [m/s]	Torque [Nm]	Stroke [m]	Torque [Nm]	Speed [m/s]	Torque [Nm]	Stroke [m]	Torque [Nm]	Speed [m/s]	Torque [Nm]	Stroke [m]	Torque [Nm]	Speed [m/s]	Torque [Nm]	Stroke [m]	Torque [Nm]
1	11	1	11	1	31	1	31	1	71	1	71	1	174	1	174
2	10	2	11	2	28	2	31	2	65	2	71	2	159	2	174
3	9	3	8	3	25	3	31	3	59	3	60	3	153	3	138
4		4	7	4	23	4	25	4	56	4	47	4	143	4	108
5		5	5	5	22	5	21	5	52	5	38	5	135	5	89



**Important:**

The maximum allowable torque at the drive shaft is the lowest value of the speed- or stroke-dependent torque value (refer to example page 11).



### 7.1.3 OSP-E..BHD

#### BHD: Linear drive with toothedbelt and integrated roller guide

Performance overview					
Characteristic		Unit	Description		
Series			OSP-E25BHD	OSP-E32BHD	OSP-E50BHD
Max. speed		[m/s]	10	10	10
Linear motion per revolution of the drive shaft		[mm]	180	240	350
Max. speed of the drive shaft		[min <sup>-1</sup> ]	3 000	2 500	1 700
Maximum effective action force with reference to the drive torque	< 1 m/s:	[N]	1 070	1 870	3 120
	1 - 3 m/s	[N]	890	1 560	2 660
	> 3-10 m/s	[N]	550	1 030	1 940
No-load torque		[Nm]	1.2	2.2	3.2
Max. acceleration /deceleration		[m/s <sup>2</sup> ]	40	40	40
Repeatability		[mm/m]	± 0.05	± 0.05	± 0.05
Max. standard stroke length		[m]	7	7	7
Tightening torque clamping hub		[Nm]	9,5	17	40

#### Max. allowable torque at the drive shaft Speed / stroke

OSP-E25BHD				OSP-E32BHD				OSP-E50BHD			
Speed [m/s]	Torque [Nm]	Stroke [m]	Torque [Nm]	Speed [m/s]	Torque [Nm]	Stroke [m]	Torque [Nm]	Speed [m/s]	Torque [Nm]	Stroke [m]	Torque [Nm]
1	31	1	31	1	71	1	71	1	174	1	10,0
2	28	2	31	2	65	2	71	2	159	2	10,0
3	25	3	31	3	59	3	60	3	153	3	138
4	23	3	25	4	56	4	47	4	143	4	108
5	22	5	21	5	52	5	38	5	135	5	89
6	21	6	17	6	50	6	32	6	132	6	76
7	19	7	15	7	47	7	28	7	126	7	66
8	18			8	46			8	120		
9	17			9	44			9	116		
10	16			10	39			10	108		



#### Important:

The maximum allowable torque at the drive shaft is the lowest value of the speed- or stroke-dependent torque value (refer to example page 11).

# Modular electrical linear drives OSP-E

## 7.1.4 OSP-E..BV

### Vertical linear drive with with toothed belt and inegrated recirculating linear ball bearing guide

Performance overview				
Characteristic		Unit	Description	
Series			OSP-E20BHD	OSP-E25BHD
Max. speed		[m/s]	3.0	5.0
Linear motion per revolution of the drive shaft		[mm]	108	160
Max. speed of the drive shaft		[min <sup>-1</sup> ]	1 700	1 875
Maximum effective action force $F_A$ with reference to the drive torque	< 1 m/s:	[N]	650	1 430
	1 - 3 m/s:	[N]	890	1 560
	> 3-5 m/s:	[N]	-	1 050
No-load torque		[Nm]	0.6	1.2
Max. acceleration /deceleration		[m/s <sup>2</sup> ]	20	20
Repeatability		[mm/m]	± 0.05	± 0.05
Max. standard stroke length		[mm]	1 000	1 000
Tightening torque clamping hub		[Nm]	4.8	9.5
Recomended permissible mass		[kg]	10	20

Max. allowable torque at the drive shaft Speed / stroke							
OSP-E20BHD				OSP-E25BHD			
Speed . [m/s]	Torque [Nm]	Stroke [m]	Torque [Nm]	Speed [m/s]	Torque [Nm]	Stroke [m]	Torque [Nm]
1	19	1	17	1	36	1	36
2	17	2	10.5	2	30		36
3	15.5			3	30		
				4	28		
				5	27		



#### Important:

The maximum allowable torque at the drive shaft is the lowest value of the speed- or stroke-dependent torque value (refer to example page11).

## 7.1.5 OSP-E..B

## Linear drive with toothed belt and internal plain bearing guide

Performance overview					
Characteristic	Unit	Description			
Series		OSP-E25B	OSP-E32B	OSP-E50B	
Max. speed	[m/s]	2	3	5	
Linear motion per revolution of the drive shaft	[mm]	60	60	100	
Max. speed of the drive shaft	[min <sup>-1</sup> ]	2 000	3 000	3 000	
Maximum effective action force $F_A$ with reference to the drive torque	< 1 m/s:	[N]	50	150	425
	1 - 2 m/s:	[N]	50	120	375
	> 2 m/s:	[N]	-	100	300
Max. acceleration /deceleration	[m/s <sup>2</sup> ]	10	10	10	
Repeatability	[mm/m]	± 0.05	± 0.05	± 0.05	
Max. standard stroke length	[m]	3.0	5.0	5.0	
Bi-Parting version		2 x 1.5	2 x 2.5	2 x 2.5	
No-load torque	[Nm]	0.4	0.5	0.6	

Max. allowable torque at the drive shaft Speed / stroke											
OSP-E25B				OSP-E32B				OSP-E50B			
Speed [m/s]	Torque [Nm]	Stroke [m]	Torque [Nm]	Speed [m/s]	Torque [Nm]	Stroke [m]	Torque [Nm]	Speed [m/s]	Torque [Nm]	Stroke [m]	Torque [Nm]
1	0.9	1	0.9	1	2.3	1	2.3	1	10.0	1	10.0
2	0.9	2	0.9	2	2.0	2	2.3	2	9.5	2	10.0
		3	0.9	3	1.8	3	2.3	3	9.0	3	9.0
						4	2.3	4	8.0	4	7.0
						5	1.8	5	7.5	5	6.0

**Important:**

The maximum allowable torque at the drive shaft is the lowest value of the speed- or stroke-dependent torque value.

**Example:**

OSP-E32B stroke 2 m, requires speed 3 m/s;

From table OSP-E..B: Speed 3 m/s means 1.8 Nm and stroke 2 m means 2.3 Nm.

The maximum torque in this application is 1.8 Nm.

## 7.2 Structural arrangement and operating mode

### 7.2.0 General arrangement

The linear drives are used in all those places where loads are to be transported and/or have to be precision-positioned.

With a combination of several linear drives, a wide-surface covering or room-orientated arrangement can be realised.

- On a slotted aluminium profile with dovetail grooves, on the ends, the end cap required for the driving elements are mounted.
- In this barrel profile, a driver is moved where supporting rings are attached to both ends. These provide the lowest possible sliding friction.
- The attachment of the load material is connected by way of threaded holes on the driver.
- Dirt is prevented from getting into the aluminium profile by a outer band made of high quality stainless steel.
- An integrated permanent magnet at OSP-E..BHD and B is used for the purpose of position detection.  
A magnetic switch set is recommended for OSP-E..BV. The magnet must be fixed in the dovetail groove.
- The linear unit is attached by means of threaded holes on the end caps.

### 7.2.1 OSP-E..BHD

**BHDII: Linear drive with toothed belt and integrated recirculating linear ball bearing guide.**

#### Design Features

- Precision guide rail in steel.
- Drive plate on guiding slide with integrated linear guidance system for ball bearings.
- Toothed belt drive with integrated planetary gear (optional).
- Motor can be mounted from below or above (optional).

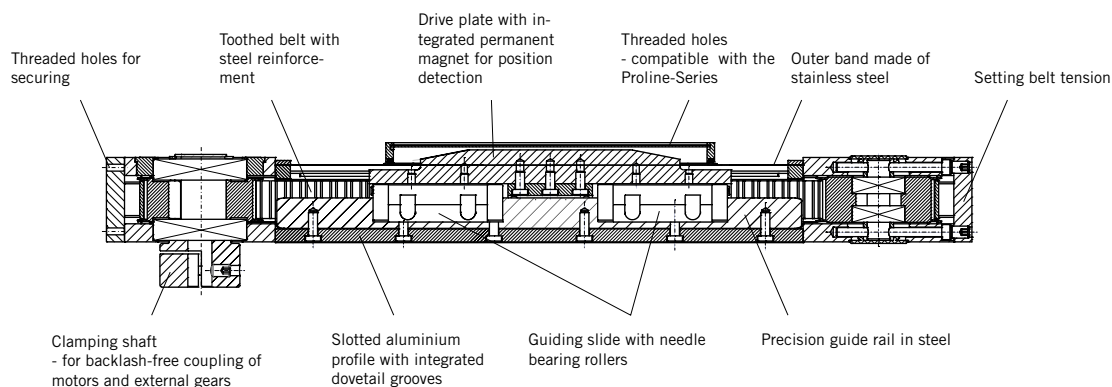

### 7.2.2 OSP-E..BHD

**BHD: Linear drive with toothed belt and integrated roller guide**

#### Design Features

- Guide rail in the aluminium profile and driver on needle-bearings
- Belt drive with integrated planetary gear (option).
- Motor attachment from above or below (option) possible

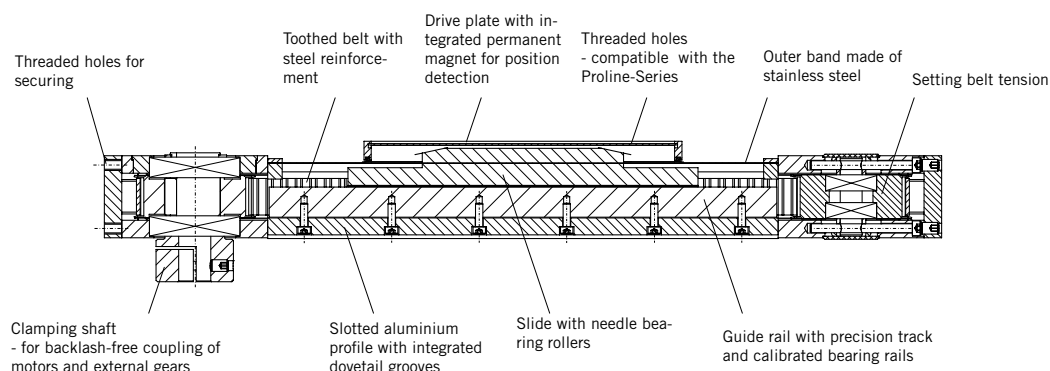

### 7.2.3 OSP-E..BV

#### Vertical Linear drive with toothed belt and integrated recirculating ball bearing guide

##### Design Features

- Linear drive for vertical movements in Z direction.
- Drive head fixed and movement through aluminium profile.
- Precision guide rail of steel.
- Fastening of the externally moving mass by means of anchor points at the end of the profile. (observe details given in the catalogue!)

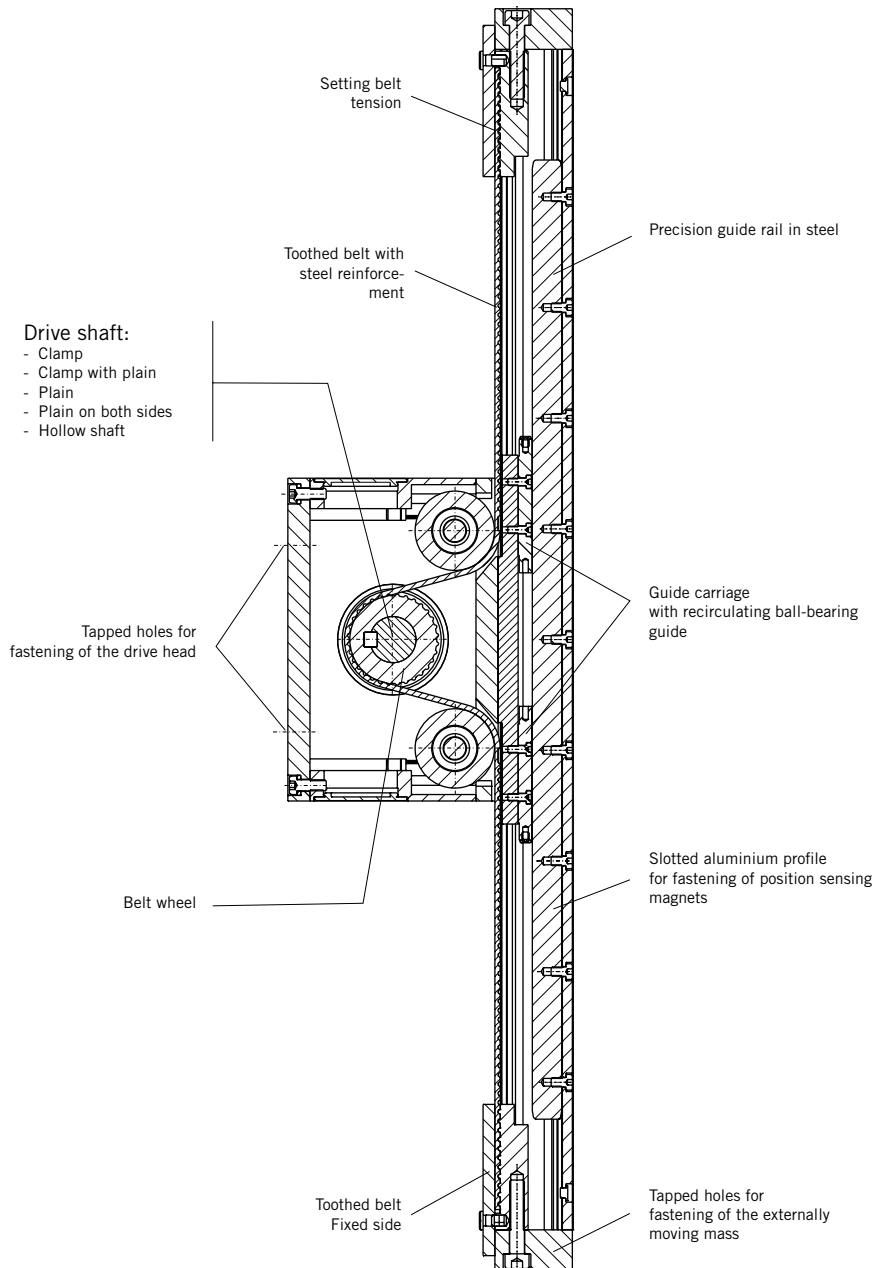

## 7.2.4 OSP-E..B

### Linear drive with toothed belt and internal plain bearing guide

#### Design Features

- Toothed belt drive for linear movements
- Toothed belt drive with threaded holes for lateral motor attachment

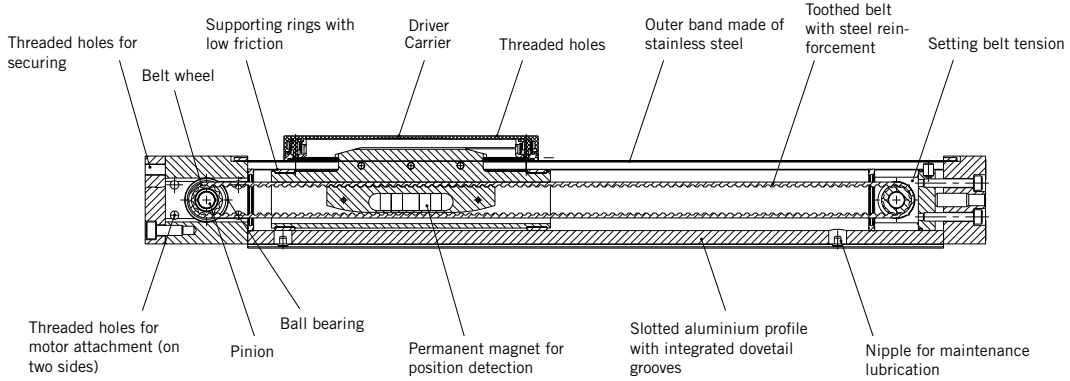

### OSP-E..B Bi-Parting version

#### Design Features

- Drive for synchronous counter movements
- Belt drive with threaded holes for lateral motor attachment

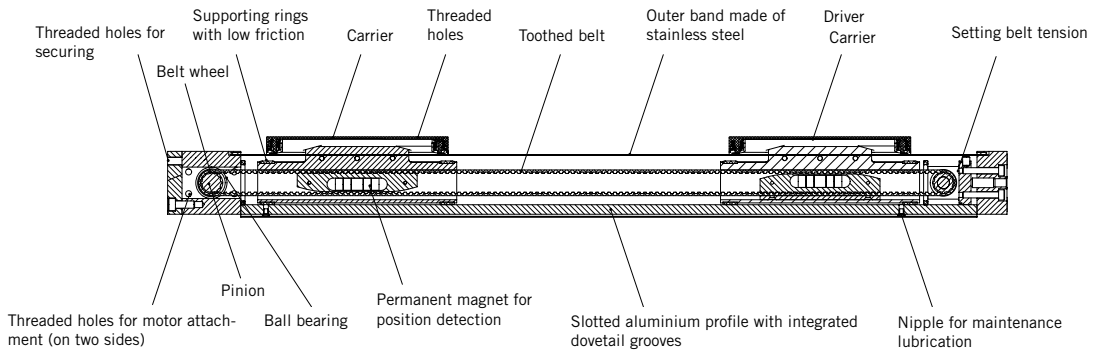

## 7.3 Maintenance / repair



### Attention

Maintenance and repair work shall only be carried out by specially trained and instructed persons !

### Attention

The machine or the working zone must be cordoned off for safety purposes as required !

### 7.3.1 Cleaning

The linear drive must be kept free from dirt particles at all times, particularly the surface between the outer band and the aluminium profile and/or the wipers at the carrier.

For cleaning, use only non aggressive cleansers and lint-free cloths.



### Attention

After every cleaning operation, the corresponding parts must be lubricated as required.

### 7.3.2 Lubrication

The roller guides and shaft bearings are lubricated for life.

We recommend an inspection of the linear drive after max. 3000 km or an operating period of 12 months, depending on the application.

The following aspects must be taken into account:

- Load
- Speed
- Temperature
- Surrounding condition of the linear drives.

#### Visual inspection for lubricating grease:

- Make sure that the outer band has a thin lubricating film on both sides.
- Make sure that the guide rail (OSP-E..BHD) is covered with a thin lubricating film as required. For this purpose, the clamping pieces for the outer band must be loosened so that this can be lifted up easily.

#### Lubrication of the running surfaces in the tube (OSP-E..B):

On the downward facing side of the linear drive, there are two grease nipples for lubricating the running surfaces. In order to perform lubrication with a grease gun, the driver must be moved into its corresponding greasing position (if necessary, inching movement in the direction of the mechanical limit position of the drive).

Refer to the table for the clearance values.

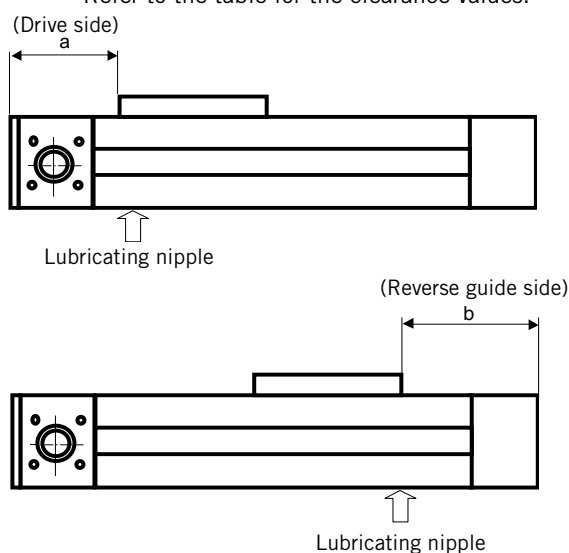

Type	Dimension a [mm]	Dimension b [mm]
OSP-E25B	64	71
OSP-E32B	73	79
OSP-E50B	98	103

#### Lubricant

- Parker-Origrease 2  
(HO-Grease 2 Ident N°.: #15071 Tube 45 gr)

## 7.3.3 Inspection of the belt tension

### OSP-E..BHD

#### Linear drive with toothed belt and integrated guide

- Move the slide far enough to the drive side until the clearance between profile of the driver edge and the centre of the pinion of the running side (opposite drive side) is 500 mm (or 250 mm for short stroke lengths).
- Take off the lateral cover strips (in the aluminium barrel profile).
- Through the side bore in the aluminium profile it is possible to measure the belt tension
- For a correct belt tension, you should be able to deflect the belt by 6 to 7 mm for an exposed belt length of 500 mm, and 3 to 3.5 mm for an exposed belt length of 250 mm.

Use a force-measuring gauge (**dynamometer FDN200 with testpin ident-no. 16187**) to read the following force:

Linear drive	Size 20	Size 25	Size 32	Size 50
Force	27N ± 1N	35N ± 0,5N	60N ± 1N	94N ± 2N

If the measured value is below the value in the table shown above, then the belt must be replaced.

- Replace the lateral cover strips (in the aluminium profile).

### OSP-E..B

#### Linear drive with toothed belt and internal plain bearing guide

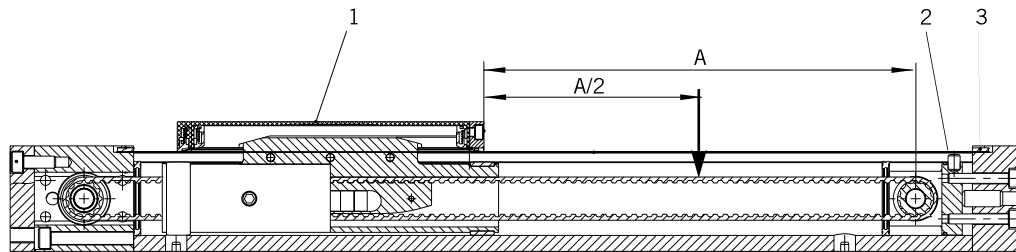

- Push the driver (1) onto the drive side.
- Release the clamping piece (3) for the outer band (2) so that the outer band can be lifted up and the slot between driver and running side is exposed.
- Move the driver far enough so that 500 mm (or 250 mm for short stroke lengths) of the belt is exposed between the profile of the driver edge and the centre of the pinion of the running side (opposite drive side) (Dimension A).
- In order to measure the belt tension, press down the belt in the centre of the exposed length in the direction of the slot (e.g. 250 mm or 125, measured from the edge of the carrier).
- For a correct belt tension, you should be able to deflect the belt by 6 to 7 mm for an exposed belt length of 500 mm, and 3 to 3.5 mm for an exposed belt length of 250 mm.

With a force-measuring gauge (**dynamometer FDN200 with testpin ident-no. 16187**) it should be possible to read the following force:

Linear drive	Size 25	Size 32	Size 50
Force	7.5N ± 0,5N	13N ± 1N	23N ± 2N

If no force-measuring gauge is available, you can carry out the test with a weight of 0.7 kg (size 25), 1.3 kg (size 32) or 2.5 kg (size 50) which is placed through the slot onto the belt.

The belt should normally deflect by max. 7 mm and min. 6 mm for an exposed belt length of 500 and max. 3.5 mm and min 3 mm for a 250 mm exposed belt length.

If the measured value is below the value in the table shown above, then the belt must be replaced.

- Reposition the outer band into place and fix with the clamping piece

### OSP-E..BV

#### Vertical linear drive with tooth belt and integrated recirculating ball bearing guide



#### Attention

The toothed belt tension adjusted by the manufacturer must not be modified.

It is not required to adjust the tension.



### 7.3.4 Tensioning the belt

#### OSP-E..BHD

##### Linear drive with toothed belt and integrated guide

- Release the set screws (3).
- Release the socket head screws (4) and remove cover (2).
- Tighten uniformly the socket head screws (1) in order to tighten the belt by moving the axle (5).
- After achieving the required belt tension, mount the cover (2) again and screw tight as required.
- Fix the position of the socket head screws (1) by tightly turning the set screws (3).

During tensioning, check the belt tension according to Chapter 7.3.3

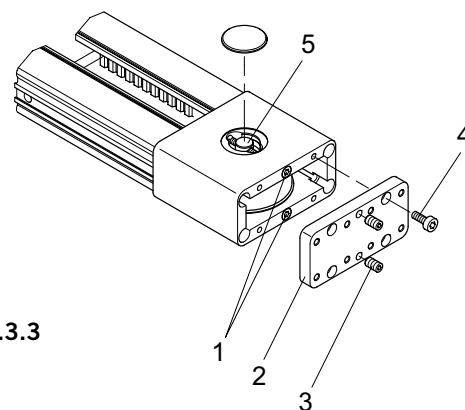

#### OSP-E..B

##### Linear drive with toothed belt and plain bearing guide

- Release the set screw (3)
- Tighten the socket head screws (2) and (4) uniformly in order to tension the belt by moving the bearing housing (1).
- After obtaining the required belt tension, fix the position of the bearing housing by tightly turning the set screw (3).

Thread size	Tightening torques socket head screws / threaded pins
M 5	6 ± 1Nm
M 6	10 ± 1,5Nm

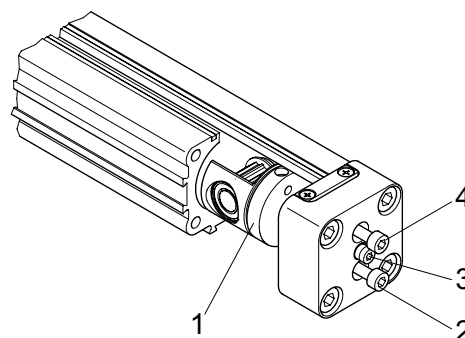

During tensioning, check the belt tension according to Chapter 7.3.3.

#### Attention

Avoid a slanted position of the axle (5) by uniformly tightening the socket head screws (1).

## Modular electrical linear drives OSP-E

### 7.3.5 Replacing the belt

#### OSP-E..BHD

Linear drive with toothed belt and integrated guide

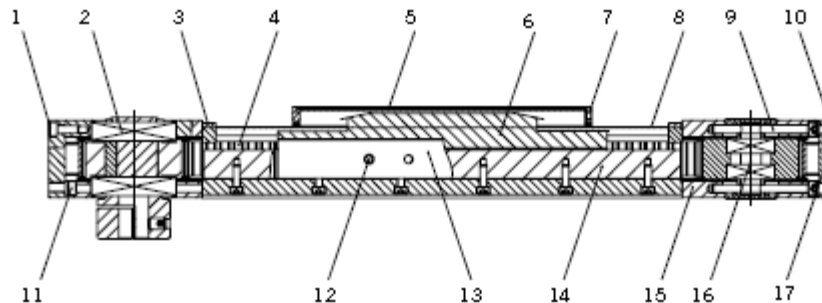

- ✦ Release and remove motor/drive unit as well as all other components attached.
  - ✦ Release and remove the components mounted on the carrier (6).
  - ✦ Release and remove the two bracing screws (7) so that the bearing housing lies loosely in the aluminium profile (5).
  - ✦ Remove the clamping pieces (3) so that the outer band (7) can be removed.
  - ✦ Release/remove the four fastening screws (10) and take off the cover plate (17).
  - ✦ Slightly loosen the two belt bracing screws (9) in order to relieve the belt wheel (16).
  - ✦ Release and remove the four fastening screws of the end cap (15).
  - ✦ Remove the end cap (15) to the rear to such an extent until the belt (4) can be pressed together by hand in order to be able to lead it through the slot of the aluminium profile (if necessary, loosen further the belt bracing screws).
  - ✦ Remove the fastening screws (1) and take off the cover plate.
  - ✦ Remove the fastening screws (11) and remove the drive end cap.
- OSP-E..BHD with recirculating linear ball bearings: Pull the slide with linear guidance system (6) to the end of the guide rail (14) at the drive housing (2). Carefully insert transportation lock for balls from the service kit into the sliding carriages. After that, completely remove carriage (6), toothed belt (4) and housing (15).
- ✦ OSP-E..BHD with roller guide: remove drive housing (2) including carrier with roller guide (6), toothed belt (4) and housing (15).
  - ✦ Remove socket head screws (12) in order to be able to remove the belt clamping plate (13).
  - ✦ The belt can now be removed



#### Attention

Check the dismantled parts for wear and replace if necessary.

Observe direction of movement with belt and carrier assembly! (Clamping in the carrier)

Do not twist the belt. Observe position of the drive end cap.

The new belt to be installed must be checked for correct length and, if necessary, shortened according to the following table.

Size	Belt length OSP-E..BHD
20	2 x Stroke length + 639 mm
25	2 x Stroke length + 830 mm
32	2 x Stroke length + 960 mm
50	2 x Stroke length + 1310 mm

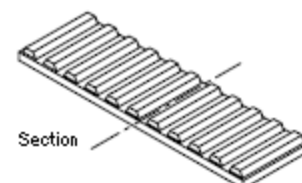

#### Information

The cut for the shortening of the belt must be made in the valley between two peaks.

The belt for the linear drive OSP-E..BP is to be divided according to the following table.

**Important:**

applies only for OSP-E..BHD..BP  
(Option carrier: bi-directional: synchronous counter movement)

- ✦ Divide belt in the middle
- ✦ Shorten the belt according to the following table

Sorting of tooth belt, bi-parting		
Size	Teeth	
	Drive side	Reverse Guide side
20	3	4
25	2	1
32	4	3
50	6	5

**Information**

After assembly, the clearance dimension (A) on both sides must be checked and corrected if necessary by offsetting the belt.

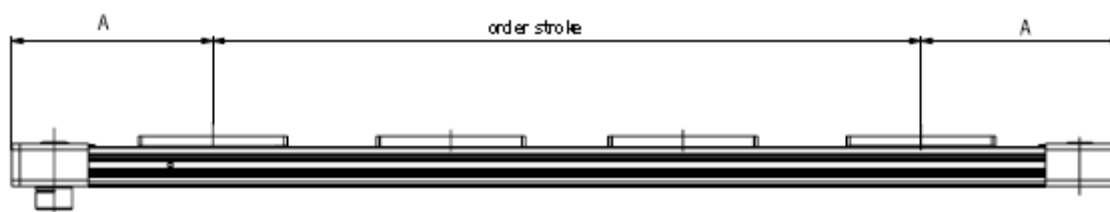

Size	Clearance Dimension A
20	185 mm
25	218 mm
32	262 mm
50	347 mm

The belt is mounted in the dismantled condition of the linear drive.

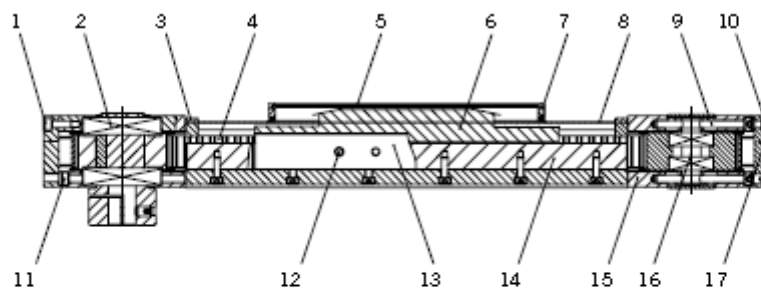

- ✦ Place the belt (4) around the belt wheels.
- ✦ Locate the belt (4) into the clamping strip (13) on both sides in such a way that, in each case, at least six teeth (size 25 and 32) and ten teeth (size 50) engage.
- ✦ Secure the clamping strip with screws at the roller shoe couple (secure with thread lock).
- ✦ Press together the belt between end cap (15) and carrier (6) and place in the slot of the aluminium profile OSP-E..BHD with recirculating ball bearing system: Carefully slide carriage with linear guidance system (6) onto the guide rail (14) and remove transportation lock for balls. Install carriage (6), drive housing (2) and linear guidance housing (15)
- ✦ OSP-E..BHD with roller guides: Push carriage with roller guides (6) onto the guide rail (14) and install drive housing (2) and housing for linear guidance (15).

# Modular electrical linear drives OSP-E

- Secure the drive end cap (2) with the four hex screws (11) at the aluminium profile (15).
- Mount the end cap (15) with hex screws at the aluminium profile.
- Tension the belt (8) in accordance with Chapter 7.3.4.
- Push the outer band (8) through the carrier(6) and screw tight on both sides with the clamping pieces (3) at the aluminium profile.
- Carefully mount and screw tight cover sheet (5) und cover with wiper (7).
- Secure both covers with hex screws to the individual casings.
- Mount again motor/drive unit as well as all other components attached to it (tightening torques clamping hub, refer to table for load values chapter 7.1 ff).
- The components attached to the carrier are to be mounted again.

Thread size	Tightening torques socket head screws
M 3	1.2 ± 0.2 Nm
M 4	3 ± 0.5 Nm
M 5	5,5 ± 0.8 Nm
M 6	10 ± 1.5 Nm

Thread size	Tightening torques countersunk screws
M 3	0,5 ± 0.1 Nm
M 4	2,2 ± 0.1 Nm

## OSP-E..BV

### Vertical linear drive with toothed belt and integrated recirculating ball bearing guide

If the toothed belt must be replaced, ask the manufacturer of the drive for possible repair.

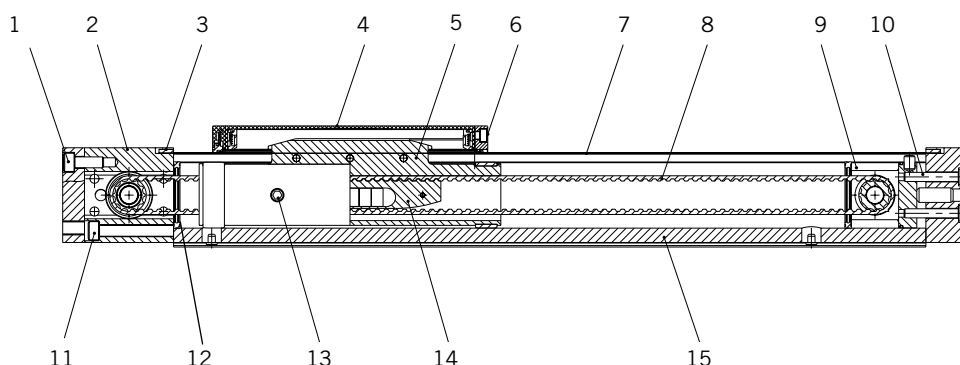
**OSP-E..B****Linear drive with toothed belt and internal plain bearing guide**

- Release and remove motor/drive unit as well as all other components attached.
- Release and remove the components mounted on the carrier (5).
- Release and remove the two bracing screws (10) so that the bearing housing (9) lies loosely in the aluminium profile (15).
- Remove the fastening screws (6) on both sides and take off carefully the covering (4) with the wipers (snap-in type). Make sure that the wipers and springs maintain their positions.
- Remove the clamping pieces (3) so that the outer band (7) can be removed.
- Remove the fastening screws (1) and take off the cover plate.
- Remove the fastening screws (11).
- Remove the drive end cap (2) including carrier (5) and bearing housing (9).
- Remove socket head screws (13) in order to be able to remove the belt clamping plate (14).
- The belt (8) can now be removed.

**Attention**

Check the dismantled parts for wear and replace if necessary.

The belt shall not be buckled as this can lead to damage.

When assembling belt and carrier, observe correct direction of movement ! (clamping in carrier)

Do not twist the belt. Observe the position of the drive casing.

The new belt to be installed must be checked for correct length and, if necessary, shortened according to the following table.

Size	OSP-E..B
25	2 x stroke length + 390 mm
32	2 x stroke length + 485 mm
50	2 x stroke length + 670 mm

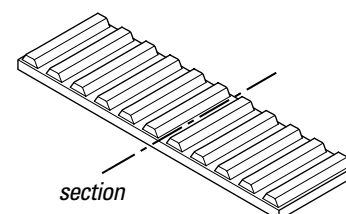
**Information**

The cut for the shortening of the belt must be made in the valley between two peaks.

The belt for the linear drive OSP-E..B in Bi-Parting version is to be divided according to the following table.

Size	Belt length	
	Drive side	Reverse guide side
25	stroke length + 200 mm	stroke length + 180 mm
32	stroke length + 252 mm	stroke length + 222 mm
50	stroke length + 345 mm	stroke length + 315 mm





## Information

After assembly, the clearance dimension (A) on both sides must be checked and, if required, corrected by shifting the belt.

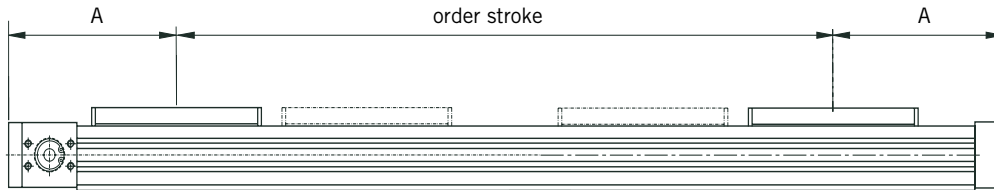

OSP-E..B	
Size	clearance dimension A
25	125 mm
32	150 mm
50	200 mm

## Mounting of the belt

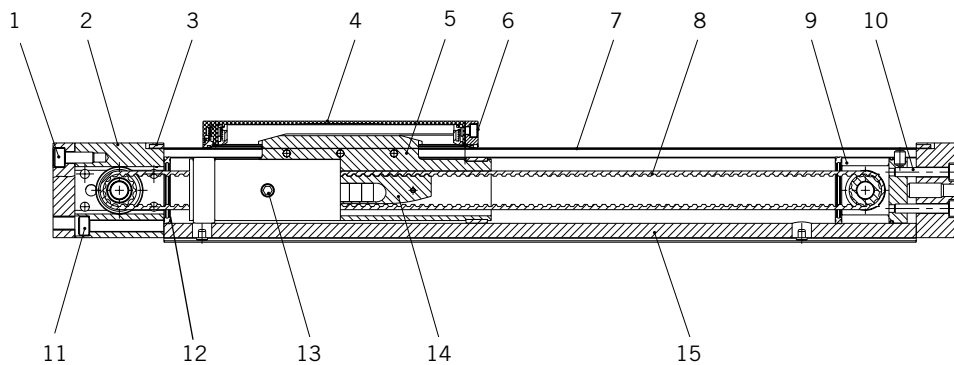

- Place belt (8) around the drive belt wheel.
- Move the X-rings over the belt (8) as these cannot be mounted after.
- Move the belt end, which is not to be clamped, correctly positioned through the carrier (5) and around the second belt wheel (do not forget the X-rings).
- Put in the belt clamping plate (14) into the carrier (5).

## OSP-E..B

- Place in the belt (8) into the belt clamping plate (14) on both sides in such a way that no tooth remains free (belt ends meet in the middle).

## OSP-E..B Bi-Parting version

- Place in the belt (8) into the belt clamping plate (14) on both sides in such a way that the middle tooth of the clamping plate remains free.
- With the screws (13) secure the belt clamping plate to the carrier (5) (and secure with thread lock).
- Move the bearing housing (9) and the carrier (5) into the aluminium profile (15)..

## Attention



**Do not twist the belt. Observe the position of the drive casing (2).**

**When assembling belt and carrier, observe correct direction of movement ! (clamping in carrier**

- With the help of the supporting rings and the slide rails, bring the carrier (5) into its correct position.
- Secure the drive end cap (2) with the four hex screws (11) at the aluminium profile (15).
- Secure the cover plate with the two hex screws (1) at the drive end cap (2).

- Tension the belt (8) in accordance with Chapter 7.3.4.
- Push the outer band (7) through the carrier and screw tight on both sides with the clamping pieces at the aluminium profile.
- With great care, mount the covering (4) with the wipers (snap-in type) and screw tight as required. Make sure that the wipers and springs maintain their positions.
- Motor/drive unit and all attached components are to be mounted again.
- The components attached to the carrier are to be mounted again.

Thread size	Tightening torques socket head screws
M 3	1.2 ± 0.2 Nm
M 4	3 ± 0.5 Nm
M 5	5.5 ± 0.8 Nm
M 6	10 ± 1.5 Nm

Thread size	Tightening torques countersunk screws
M 3	0.5 ± 0.1 Nm
M 4	2.2 ± 0.1 Nm

### 7.3.6 Replace wiper / outer band

If the wipers are worn, these must be replaced accordingly.

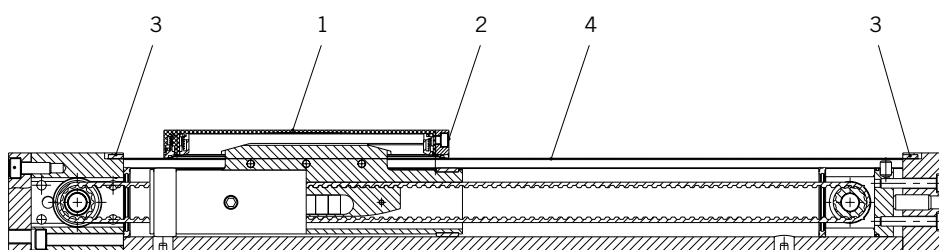

- Loosen and remove the components mounted on the carrier.
- Remove the fastening screws (2) on both sides and take off carefully the covering (1) with the wipers (snap-in type). Make sure that the wipers and springs maintain their positions.
- The new wipers can now be mounted again.

**If the outer band has visible damage so that dirt can get into the aluminium profile, it must be replaced immediately.**

- Dismantle wipers.
- Remove clamping pieces (3) so that the outer band (4) can be removed and replaced

Thread size	Tightening torques countersunk screws
M 3	0,5 ± 0.1 Nm
M 4	2,2 ± 0.1 Nm

### 7.3.7 Replace bearing strips / bearing rings

The clearance between the bearing strips (2) and the aluminium profile should be maximum 0.2 mm. Any excess of this value means that the bearing strips must be replaced.

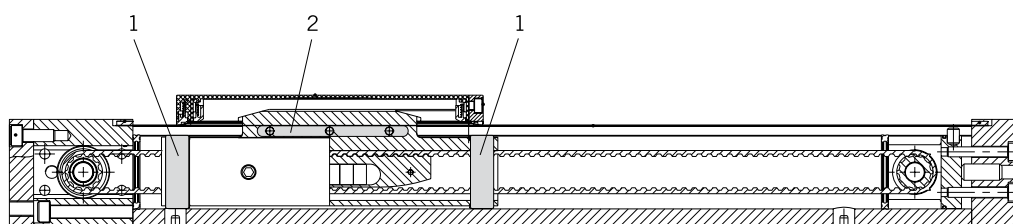

- Dismantle the drive in accordance with Chapter 7.3.4 (do not dismantle the belt !)
- Remove both bearing strips (2) and replace with new bearing strips of the same colour.
- Inspect the supporting rings (1) for wear and, if necessary, replace with new supporting rings of the same thickness.

## 7.3.8 Check the bearings

If there is increased noise development with the movement of the linear drives, the bearings must be inspected for wear.

Such an inspection should be carried out every 3000 km running performance or every 12 months.

- Loosen and remove motor/drive unit as well as all other components attached.
- Inspect belt and guides for possible dirt (loosen outer band and lift up for visual inspection).
- Turn drive shaft by hand in both directions. This should be possible without jolts and with easy movement. In order to check the running behaviour in a better way, if necessary, mount coupling on drive axle. Observe torque for no-load run ! (see page 8/10)
- If this is not possible, the linear drive must be dismantled and the damaged bearing replaced.

## 8 Spindle drives OSP-E..SB / OSP-E..ST / OSP-E..SBR / OSP-E..STR

---

### 8.1 Technical data

#### 8.1.1 General



Detailed information on

- dimensions,
- space requirement,
- weights

are shown in the OSP-E catalogue.

For all linear drives of the product series OSP-E, the following applies:

#### Temperature ranges:

- OSP-E..SB -20°C to +80°C.
- OSP-E..ST -20°C to +70°C.
- OSP-E..SBR -20°C to +80°C.
- OSP-E..STR -20°C to +70°C.

Installation location: no specific requirements

**We reserve the right to make technical alterations !**



### 8.1.2 OSP-E..SB

#### Linear drive with ball screw drive and internal plain bearing guide

Performance overview								
Characteristic	Unit	Description						
Series		<b>OSP-E25SB</b>	<b>OSP-E32SB</b>		<b>OSP-E50SB</b>			
Pitch	[mm]	5	5	10	5	10	25	50
Max. speed	[m/s]	0.25	0.25	0.5	0.25	0.5	1.25	2.5
Linear motion per revolution of the drive shaft	[mm]	5	5	10	5	10	25	50
Max. speed of the drive shaft	[min <sup>-1</sup> ]	3 000	3 000		3 000			
Maximum effective action force $F_A$ with reference to the drive torque	[N]	250	600		1 500			
	[Nm]	0.35	0.75	1.3	1.7	3.1	7.3	14.6
No-load torque	[Nm]	0.2	0.2	0.3	0.3	0.4	0.5	0.6
Max. allowable drive torque at the drive shaft	[Nm]	0.6	1.5	2.8	4.2	7.5	20	20
Repeatability	[mm/m]	± 0.05	± 0.05		± 0.05			
Max. standard stroke length	[m]	1.1	2.0		3.2			

### 8.1.3 OSP-E..ST

#### Linear drive with trapezoidal screw drive and internal plain bearing guide

Performance overview				
Characteristic	Unit	Description		
Series		<b>OSP-E25ST</b>	<b>OSP-E32ST</b>	<b>OSP-E50ST</b>
Pitch	[mm]	4	4	6
Max. speed	[m/s]	0.1	0.1	0.15
Linear motion per revolution of the drive shaft	[mm]	4	4	6
Max. speed of the drive shaft	[min <sup>-1</sup> ]	1 500	1 500	1 500
Maximum effective action force $F_A$ with reference to the drive torque	[N]	600	1 300	2 500
	[Nm]	1.35	3.2	8.8
No-load torque	[Nm]	0.3	0.4	0.5
Max. allowable drive torque at the drive shaft	[Nm]	1.55	4.0	9.4
Self-locking $F_L$	[N]	600	1300	2500
Repeatability	[mm/m]	± 0.5	± 0.5	± 0.5
Max. standard stroke length	[m]	1.1	2.0	2.5

## 8.1.4 OSP-E..SBR

Linear drive with ball screw drive, internal plain bearing guide and piston rod

Performance overview							
Characteristic	Unit						
Series		OSP-E25SBR	OSP-E32SBR		OSP-E50SBR		
Pitch	[mm]	5	5	10	5	10	25
Max. speed	[m/s]	0.25	0.25	0.5	0.25	0.5	1.25
Linear motion per revolution of the drive shaft	[mm]	5	5	10	5	10	25
Max. speed of the drive shaft	[min <sup>-1</sup> ]	3 000	3 000		3 000		
Maximum effective action force $F_A$ with reference to the drive torque	[N]	250	550	1090	750	990	1680
	[Nm]	0.3	0.65	2.6	0.9	2.4	10
No-load torque	[Nm]	0.2	0.2	0.3	0.3	0.4	0.5
Max. allowable drive torque at the drive shaft	[Nm]	0.6	1.5	2.8	4.2	7.5	20
Repeatability	[mm/m]	± 0.05	± 0.05		± 0.05		
Max. standard stroke length	[mm]	500	500		500		

## 8.1.5 OSP-E..STR

Linear drive with trapezoidal screw drive, internal plain bearing guide and piston rod

Performance overview				
Characteristic	Unit			
Series		OSP-E25STR	OSP-E32STR	OSP-E50STR
Pitch	[mm]	3	4	5
Max. speed	[m/s]	0.075	0.1	0.125
Linear motion per revolution of the drive shaft	[mm]	3	4	5
Max. speed of the drive shaft	[min <sup>-1</sup> ]	1 500	1 500	1 500
Maximum effective action force $F_A$ with reference to the drive torque	[N]	800	1 600	3 300
	[Nm]	1.35	3.4	9.25
No-load torque	[Nm]	0.3	0.4	0.5
Max. allowable drive torque at the drive shaft	[Nm]	1.7	4.4	12
Self-locking FI	[N]	800	1600	3300
Repeatability	[mm/m]	± 0.5	± 0.5	± 0.5
Max. standard stroke length	[m]	0.5	0.5	0.5

## 8.2 Structural arrangement and operating mode

### 8.2.1 General arrangement

The linear drives are used in all those places where loads are to be transported and/or have to be precision-positioned.

With a combination of several linear drives, a wide-surface covering or room-orientated arrangement can be realised.

- On a slotted aluminium profile with dovetail grooves, on the ends, the end cap required for the driving elements are mounted.
- In this barrel profile, a carrier is moved where supporting rings are attached to both ends. These provide the lowest possible sliding friction.
- The attachment of the load material is connected by way of threaded holes at the carrier.
- Dirt is prevented from getting into the aluminium profile by an outer band made of high quality stainless steel.
- An integrated permanent magnet is used for the purpose of position detection.
- On the side of the drive shaft there are end cap screws with internal threads for securing the coupling housing and the flange plate.

### 8.2.2 OSP-E..SB

#### Linear drive with ball screw drive, internal plain bearing guide and piston rod

##### Design Features

- Ball screw drive
- internal plain bearing guide

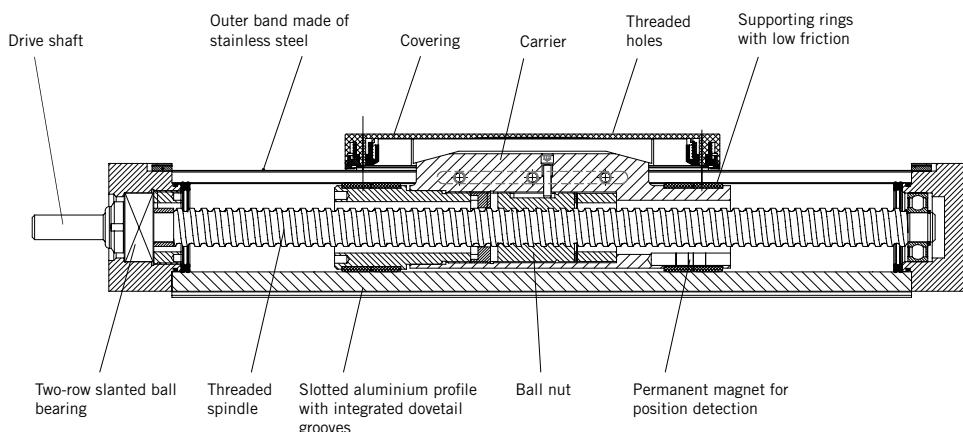

### 8.2.3 OSP-E..ST

#### Linear drive with trapezoidal screw drive, internal plain bearing guide and piston rod

##### Design Features

- Trapezoidal thread drive
- self locking

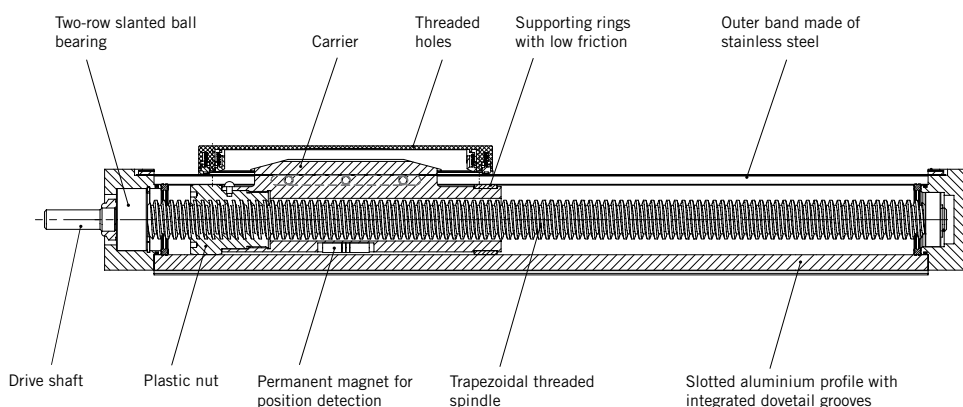

## 8.2.4 OSP-E..SBR

### Linear drive with ball screw drive, internal plain bearing guide and piston rod

#### Design Features

- Ball screw spindle
- Piston rod made of stainless steel

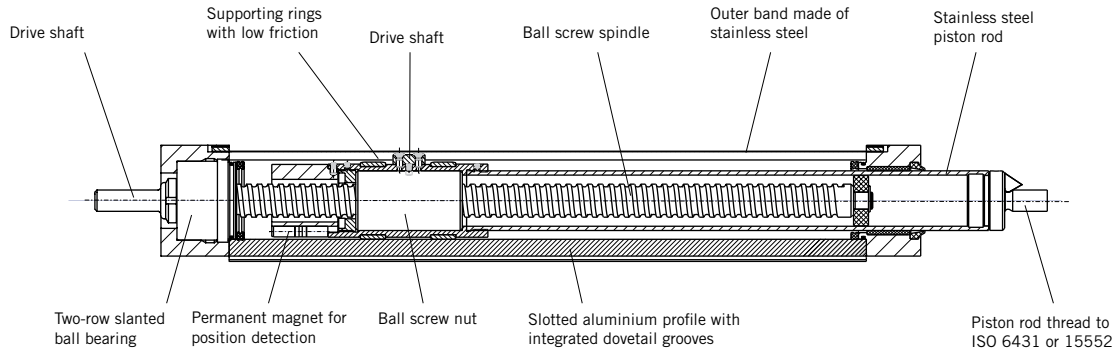

## 8.2.5 OSP-E..STR

### Linear drive with trapezoidal screw drive, internal plain bearing guide and piston rod

#### Design Features

- Trapezoidal thread drive
- Piston rod made of stainless steel

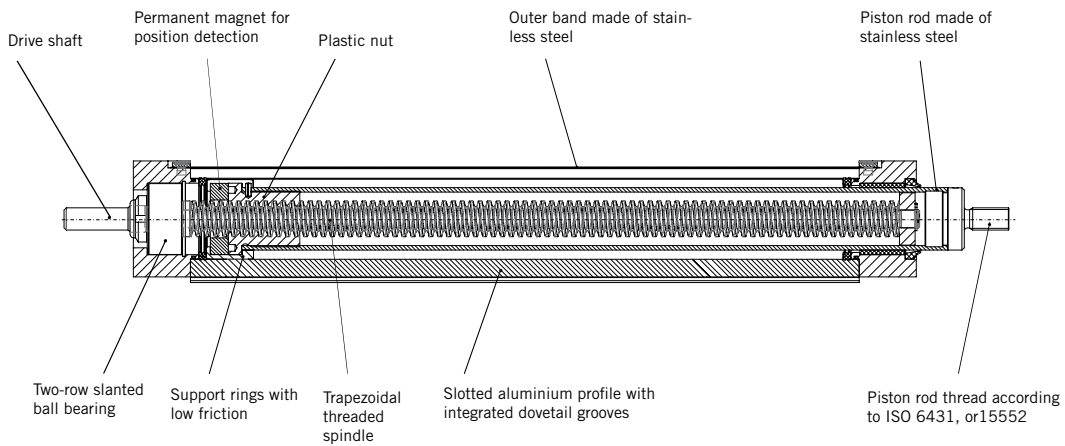

## 8.3 Maintenance / repair



### Attention

Maintenance and repair work shall only be carried out by specially trained and instructed persons !  
The machine or the working zone must be cordoned off for safety purposes as required !

### 8.3.1 Cleaning

The linear drive must be kept free from dirt particles at all times, particularly the surface between the outer band and the aluminium profile and/or the wipers at the carrier.

For cleaning, use only non aggressive cleansers and lint-free cloths.



### Attention

After every cleaning operation, the corresponding parts must be lubricated as required.

### 8.3.2 Lubrication

The shaft bearings have life-long lubrication.

The following aspects of the linear drives must be taken into account:

- Load
- Speed
- Temperature
- Surrounding condition

#### Lubricant for trapezoidal and ball screw spindle as well as cylinder tube

- Parker-Origre-grease 2 (HO-Grease 2 Ident N°.: #15071 Tube 45 gr)

#### Inspection interval for linear drive OSP-E..SB and OSP-E..SBR

Carry out a visual inspection after an operating period of max. 3000 km or 12 months.

#### Inspection interval for linear drive OSP-E..ST and OSP-E..STR

Carry out a visual inspection after an operating period of max. 300 km or 24 months.

#### Visual inspection for lubricating grease

- Make sure that the outer band/piston rod has always a thin lubricating film on both sides.
- Make sure that the spindles are covered with a thin lubricating film. For this purpose, the clamping pieces for the outer band must be loosened so that this can be lifted up easily.

#### Lubricating the drive OSP-E..SB and OSP-E..ST

- Push the carrier (1) into the central position.
- Loosen clamping pieces (2) and lift up the outer band (3).
- Place a line of grease on the threaded spindle and the inside of the tube.
- Push the driver backward and forward a few times by hand to over the entire guide length.
- Tightly clamp the outer band again.

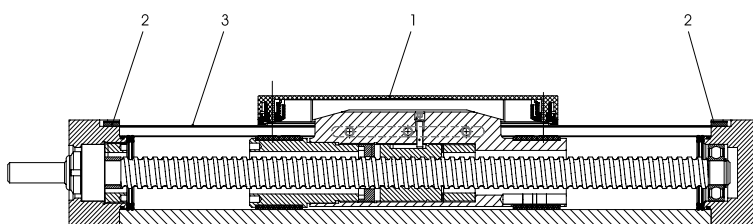

Thread size	Tightening torques countersunk screws
M 3	0,5 ± 0,1 Nm
M 4	2,2 ± 0,1 Nm

## Lubricating the spindle of linear drive OSP-E..SBR and OSP-E..STR

- Remove the motor / drive unit from the drive shaft (1).
- Move the piston rod (29) by hand into the extended position.
- Release the countersunk screws (4) and clamping piece (5). Lift the cover band (14).
- Dispense a continuous string of grease on to the threaded spindle (13) and the inside of the tube (22)).
- Move the piston rod (29) by hand several times through the complete stroke.
- Reposition the cover band (14). Put the clamping piece (5) back into place and insert the counter-sunk screws (4), tightening them to the appropriate torque.
- After the lubrication the motor / drive unit is ready to be mounted again.

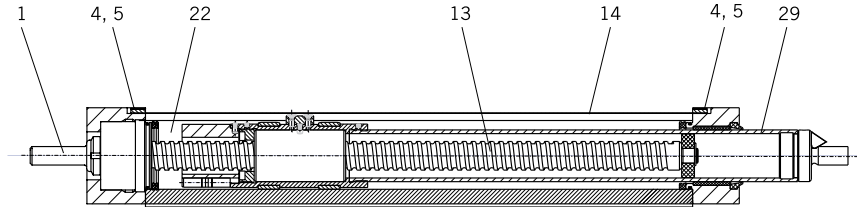

Thread size	Tightening torques countersunk screws
M 3	0,5 ± 0,1 Nm
M 4	2,2 ± 0,1 Nm

### 8.3.3 Check axle backlash of drive spindles

#### Inspection of the axle backlash of the drive spindles

- The axle backlash of the drive spindles is determined by axially moving the carrier (1) (OSP-E..SB / OSP-E..ST) and/or the piston rod (2) (OSP-E..SBR / OSP-E..STR) at machine standstill.

The determined clearance should not exceed:

- **OSP-E..S** 0.2 mm
- **OSP-E..ST** 0.5 mm
- **OSP-E..SBR** 0.2 mm
- **OSP-E..STR** 0.5 mm



#### Attention

If the allowable backlash clearance is exceeded, the spindle nuts and/or the spindles must be replaced.

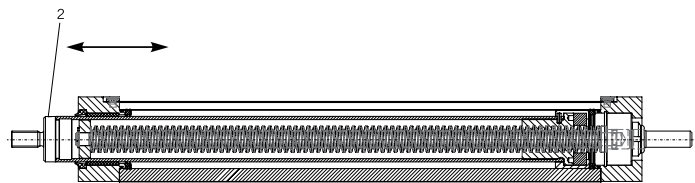
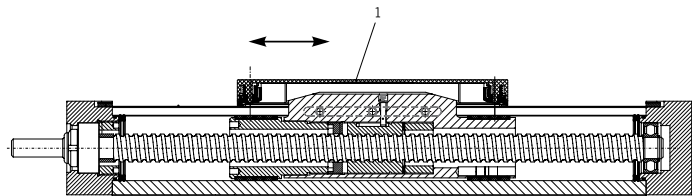

### 8.3.4 Replacing the spindle nut / spindle

#### OSP-E..SB

Linear drive with ball screw drive and internal plain bearing guide



#### Information

The exchange of the ball screw spindle requires perfect coordination. The ball screw nut must be adjusted precisely in order to avoid premature wear due to faulty installation.

The spindle must only be repaired by Parker-Origa GmbH or separately instructed personnel.

## OSP-E..ST

## Linear drive with trapezoidal screw drive and internal plain bearing guide

## Dismantling spindle / spindle nut

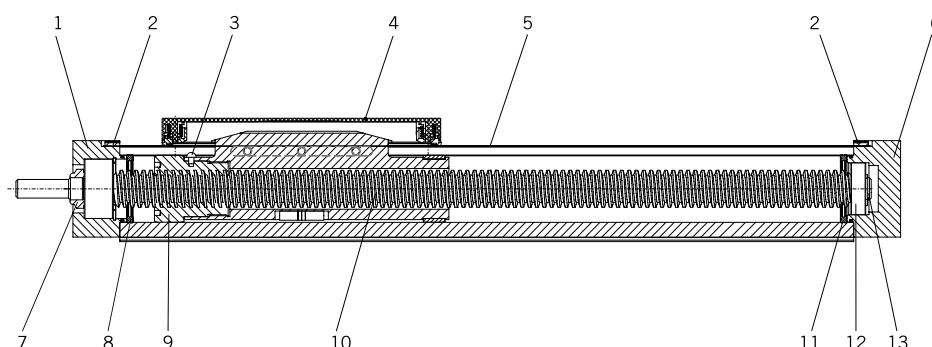

- Release and remove motor/drive unit as well as all other components attached.
- Release and remove the components mounted on the carrier (4).
- Release clamping pieces (2) and remove clamp.
- Remove outer band (5).
- By releasing the fastening screws, separate the end cap (6) from the aluminium profile and remove from the spindle.
- Separating the end cap (1) from the aluminium profile by loosening the fastening screws.
- Take out the carrier (4) with the trapezoidal threaded spindle from the aluminium profile.
- Remove circlip (13), ball bearing (12) and X-ring (11).
- Turn out carrier with spindle nut (9).
- Remove locking screw (3).
- Replace spindle nut (9).
- In order to change the trapezoidal threaded spindle (10), loosen the locking nut (7), remove end cap (1) with ball bearing (drive side) and X-ring (8)

## Installing the spindle nut

- Screw in the new spindle nut up to the stop in the carrier.
- Drill hole for locking screw (3) in spindle nut (anti-rotation) in accordance with the following table.

Size	Diameter	Depth
25	2,2 mm	5 mm
32	2,5 mm	5 mm
50	3,1 mm	5 mm

**Attention**

**Do not drill into the thread itself !**

- Screw in the locking screw (3)

## Installing the trapezoidal threaded spindle

- Turn the trapezoidal threaded spindle (10) into the spindle nut (9).
- The assembly of the spindle and ball screw nut is carried out in the reverse sequence of the disassembly.

Thread size	Tightening torques countersunk screws
M 3	0.5 ± 0.1 Nm
M 4	2.2 ± 0.1 Nm

Thread size	Tightening torques socket head screws
M 3	1,2 ± 0.2 Nm
M 4	3 ± 0.5 Nm
M 5	5,5 ± 0.8 Nm
M 6	10 ± 1.5 Nm

Thread size	Tightening torques locking nut
M 8	10 ± 1.5 Nm
M 12	24 ± 2 Nm
M 17	30 ± 2 Nm

## OSP-E..STR

### Linear drive with trapezoidal screw drive, internal plain bearing guide and piston rod

#### Dismantling the spindle / spindle nut

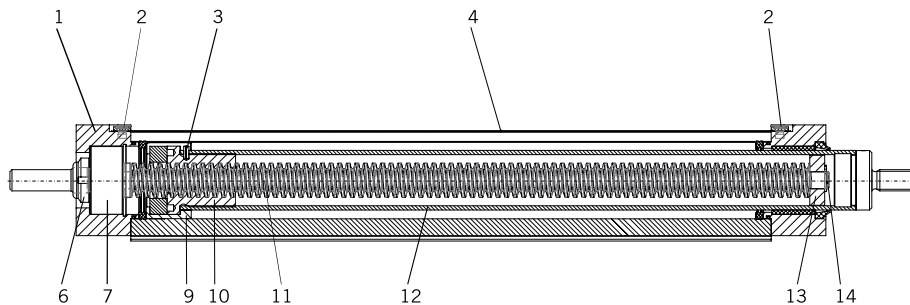

- Release and remove motor/drive unit as well as all other components attached.
- Release clamping pieces (2) and remove clamp.
- Remove outer band (4).
- By loosening the fastening screws, separate the drive end cap (1) from the aluminium profile and take out completely the spindle (11) with the piston rod (12).
- Remove the supporting ring (9).
- Remove the locking pin (3).
- Turn out the spindle nut (10) from the piston rod and take out the spindle.
- Remove retaining ring (14) and supporting bearing (13).
- Turn out the spindle nut.
- In order to change the trapezoidal spindle (11), loosen the locking nut (6) and remove the drive end cap (1) with ball bearing (7)

#### Installing the spindle nut / trapezoidal threaded spindle

- Screw a new spindle nut onto the trapezoidal threaded spindle.
- Screw in the spindle nut up to the stop into the piston rod profile.
- Drill a hole for locking pin (3) in spindle nut (anti-rotation) in accordance with the following table.

Size	Diameter	Depth
25	2.5 mm	4 mm
32	2.5 mm	4 mm
50	3 mm	6 mm

#### Attention

##### Do not drill into the thread itself !

- Screw in the locking screw (3).
- Assemble the dismantled parts again in reverse order (torques, refer to OSP-E..ST, above).





### 8.3.5 Replacing the wiper / outer band

If the wipers are worn down (OSP-E..S and OSP-E..ST), these must be replaced accordingly.

- Loosen and remove the components mounted on the carrier.

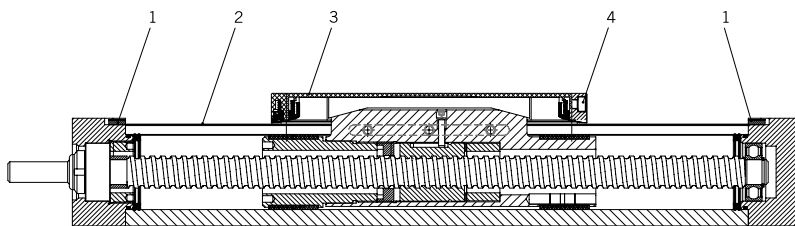

- Remove the fastening screws (4) on both sides and take off carefully the covering (3) with the wipers (snap-in type). Make sure that the wipers and springs maintain their positions.
- The new wipers can now be mounted again.

**If the outer band has visible damage so that dirt can get into the aluminium profile, it must be replaced immediately.**

- Dismantle wipers (OSP-E..S and OSP-E..ST).
- Remove clamping pieces (1) so that the outer band (2) can be removed and replaced.

Thread size	Tightening torques countersunk screws
M 3	0.5 ± 0.1 Nm
M 4	2.2 ± 0.1 Nm

### 8.3.6 Replacing bearing strips (OSP-E..S and OSP-E..ST) / supporting rings

The clearance between the bearing strips (1) and the aluminium profile should be maximum 0.2 mm. Any excess of this value means that the slide rails must be replaced.

- Dismantle drive according to Chapter 8.3.4 (do not dismantle spindle and nut !)

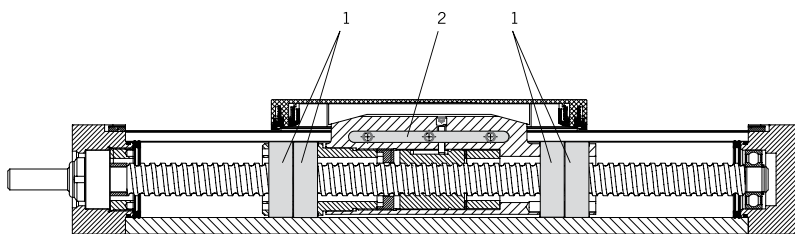

- Remove both bearing strips (2) and replace with new bearing strips of the same colour.
- Check both supporting rings (1) for wear and replace, if necessary, by new supporting rings with the same thickness.

### 8.3.7 Checking the bearings

If there is increased noise development with the movement of the linear drives, the bearings must be inspected for wear.

We recommend an inspection of the linear drives (**OSP-E..ST** and **OSP-E..STR**) after an operating duration of max. 300 km or 24 months.

An inspection of the linear drive **OSP-E..SB** and **OSP-E..SBR** should be carried out after an operating duration of max. 3000 km or 12 months.

- Release and remove motor/drive unit as well as all other components attached.
- Check the spindles and guides for possible dirt (loosen outer band and lift up for visual inspection).
- Turn drive shaft by hand in both directions. This should be possible without jolts and with easy movement. In order to check the running behaviour in a better way, if necessary, mount coupling on drive axle. Observe torque for no-load run ! (see cap. 7.1...)
- If this is not possible, the linear drive must be dismantled and the damaged bearing replaced.

## 9 Accessories

### 9.1 Multi-axle system

With the use of **Parker-Origa** adapter plates, profile attachments and/or intermediate drive shafts, the connection of linear drives in a multi-axle arrangement is possible.  
Further information on this subject can be found in the OSP-E catalogue.

### 9.2 Linear guides

The **Origa System Plus-OSP** offers the possibility of adapting various types of guides to the linear drive.  
Further information on this subject is available in the OSP-E catalogue or in the separate operating instructions for guides and brakes.

### 9.3 Mountings and sensors

With the help of the comprehensive range of **Parker-Origa** accessories for mounting components, the linear drives can be secured depending on the surrounding conditions.

With the **Parker-Origa** sensors, a non-contact scanning of the linear drives is achieved at end and/or intermediate positions.

Further information on this subject can be found in the OSP-E catalogue.

### 9.4 Couplingbox and coupling

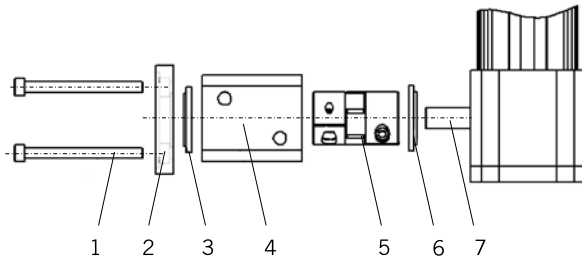

#### 9.4.1 OSP-E belt drive

- Push the location ring (6) over the drive shaft (7) until this is positioned in the cover of the drive. Observe and ensure correct location of the location ring !
- Connect the coupling (5) with the drive shaft (7) in such a way that there is a defined clearance "X", as stated in the table
- or make sure that the hex screw at the motor end of the coupling is accessible through the window in the coupling housing (4).
- Secure coupling (5) to the drive shaft (7).
- Push the coupling housing (4) onto the location ring (6).

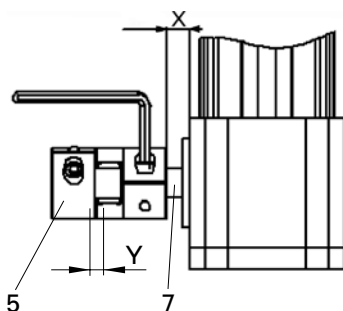

Size	Dimension „X“	Dimension „Y“	Tightening torque
OSP-E20BHD	6,4 mm	2 mm	10,5 Nm
OSP-E20BV	6,4 mm	2 mm	10,5 Nm
OSP-E25BV	13 mm	2 mm	10,5 Nm
OSP-E25B	14 mm	1 mm	0,76 Nm
OSP-E32B	10 mm	1,5 mm	1,34 Nm
OSP-E50B	5 mm	2 mm	10,5 Nm

- Place location ring (3) into the coupling housing. Observe and ensure correct location of the location ring !

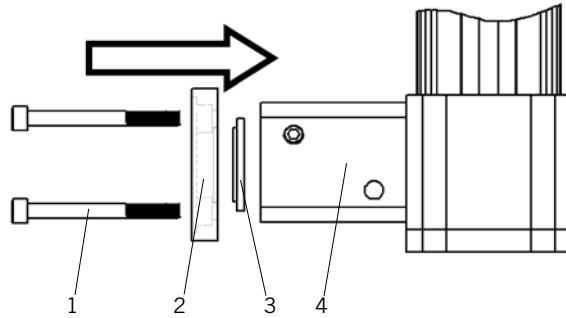

- Fix-position the motor flange (2) at the coupling housing (4).
- Secure the coupling unit at the linear drive with the screws (1).
- Tightly screw the motor to the motor flange (2).
- Tighten the screws of the coupling through the window of the coupling case (4). Use a screw driver to assist in the alignment of the screws. This can be inserted into the notch at the coupling and the coupling can then be turned into the desired position.
- Insert the plugs into the coupling housing to prevent the penetration of dirt.

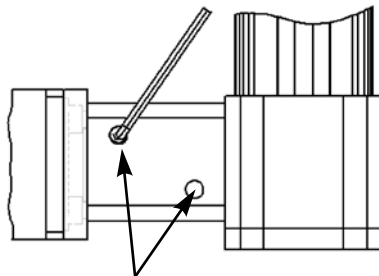

**Attention**

Some motor systems (e.g., Servo) are to be adjusted in advance before they are connected up to the drive.

**9.4.2 OSP-E spindle drive**

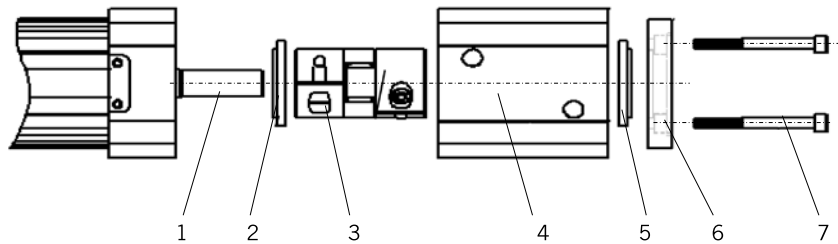

- Push the location ring (2) over the drive shaft (1) until this is positioned in the cover of the drive. Observe and ensure correct location of the location ring !
- Connect the coupling (3) with the drive shaft (1) in such a way that there is a defined clearance "X", as stated in the table
- or make sure that the hex screw at the motor end of the coupling is accessible through the window in the coupling housing (4).

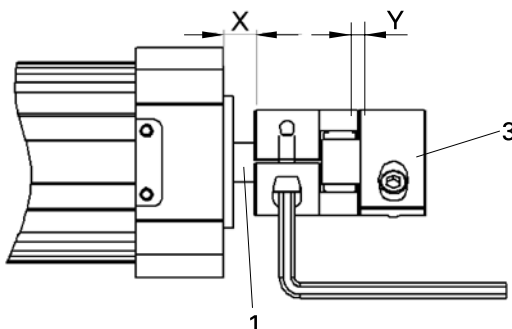

Size	Dimension „X“	Dimension „Y“	Tightening torque
25	5 mm	1 mm	0,76 Nm
32	15 mm	1,5 mm	1,34 Nm
50	13 mm	2 mm	10,5 Nm

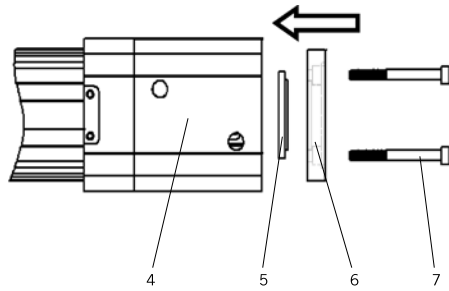

- Secure coupling (3) on the drive shaft.
- Push the coupling housing (4) onto the location ring of the drive (6).
- Place fitting ring (5) into the coupling housing. Observe and ensure correct location of the location ring !
- Fix-position the motor flange (6) at the coupling housing (4).
- Secure the coupling unit at the linear drive with the screws (7).
- Tightly screw the motor to the motor flange (6).
- Tighten the screws through the window of the coupling housing. Use a screw driver to assist in the alignment of the screws. This can be inserted into the notch at the coupling and the coupling can then be turned into the desired position.

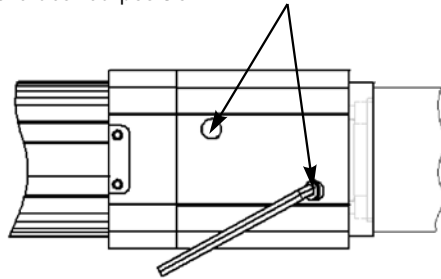

- Insert the plugs into the coupling housing to prevent the penetration of dirt.



## Attention

Some motor systems (e.g., Servo) are to be adjusted in advance before they are connected up to the drive.

## 9.5 Synchronous belt drive with configuration capability

### 9.5.1 Design Features

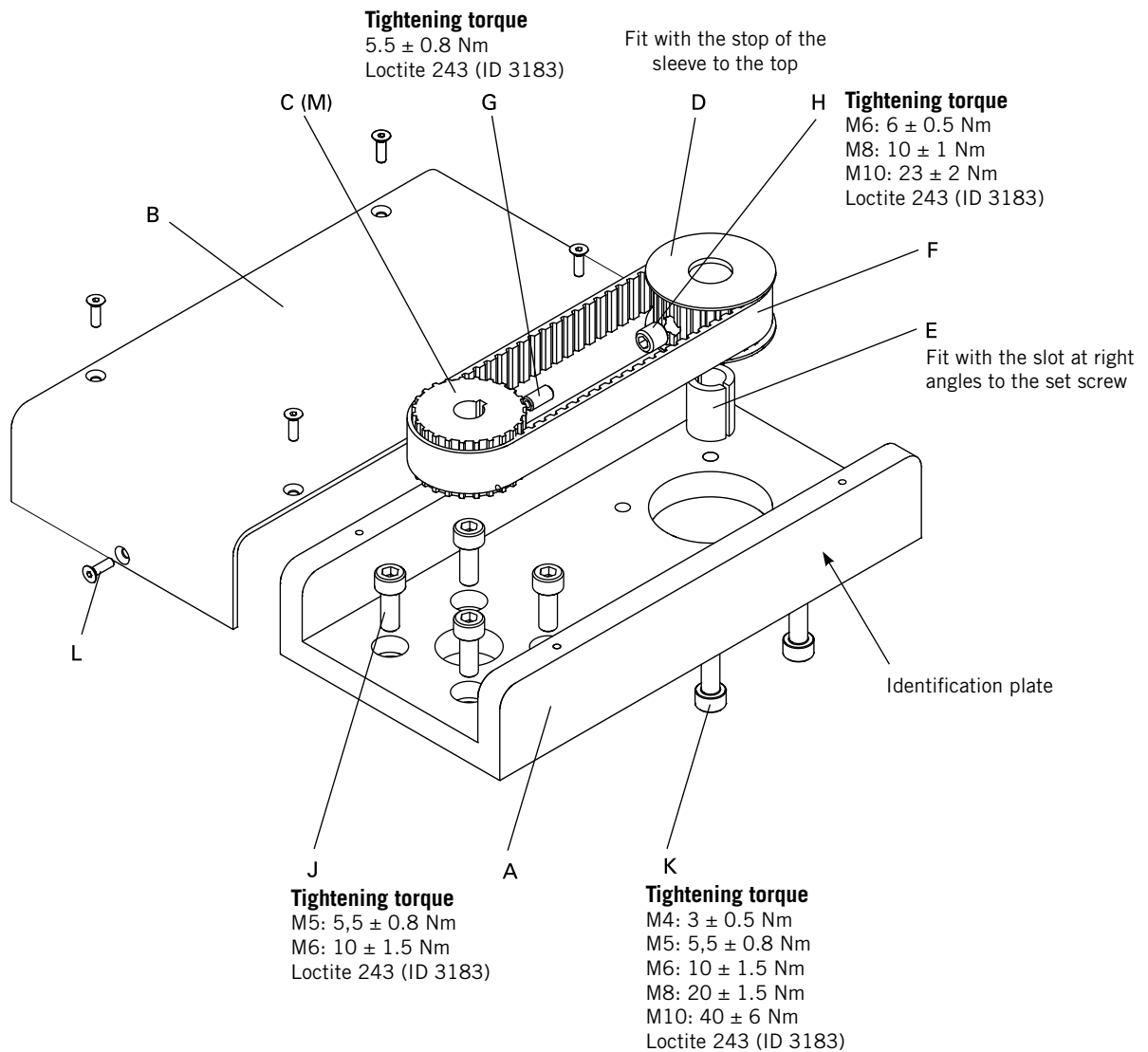

POS	DESIGNATION
A	FLANGE PLATE
B	COVER
C	COG BELT WHEEL A T5 DRIVE SIDE
D	COG BELT WHEEL A T5 MOTOR SIDE
E	CLAMPING SLEEVE
F	COG BELT
G	SOCKET SET SCREW DRIVE SIDE
H	SOCKET SET SCREW MOTOR SIDE
J	SOCKET HEAD CAP SCREW DRIVE SIDE
K	SOCKET HEAD CAP SCREW MOTOR SIDE
L	COUNTERSUNK SCREW M3 X 10 DIN 7991
	IDENTIFICATION PLATE

#### Parts for the option „smooth drive shaft“

POS	DESIGNATION
C	COG BELT WHEEL ACTUATOR A T5 DRIVE SIDE
M	CLAMPING SLEEVE

## 9.5.2 Sequence of assembly:

### Pay attention to tightening torque.

- Fit the motor to the flange plate.
- Fit the linear drive to the flange plate ensuring that the axles centres are set at the correct distance apart. (See table)
- Push on belt wheels and feed on timing belt. (See drawing)
- Set the clearance between the belt wheel and flange face to 1.5+/- 0.5mm and tighten the locking screws.
- Install toothed belts and correct centre distance if necessary.
- Fit the cover plate.

Size	OSP-E25		OPS-E32		OSP-E50	
Transmission ratio	1:1	2:1	1:1	2:1	1:1	2:1
Axle-centres [mm]	110	109.3	110	111.4	135	133.7

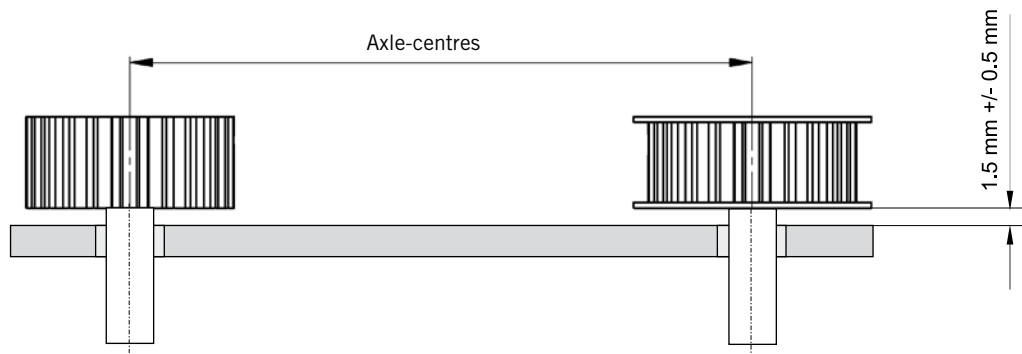

## 10 Manufacturer's statement



### Manufacturer's Declaration

in accordance with EU-Directives Machinery (89/392/ EC, replaced by 98/37/EU appendix II B)

The design of the OSP-E:

Types: **OSP-E..BHD / OSP-E..BV / OSP-E..B**  
**OSP-E..SB / OSP-E..ST / OSP-E..SBR / OSP-E..STR**

is developed, designed and manufactured in compliance with Guidelines 98/37/EU and is the sole responsibility of

Company:

**Parker-Origa GmbH**  
**Industriestraße 8**  
**DE-70794 Filderstadt**

To the OSP-E following related standards apply:

- DIN EN ISO 12100, Safety of Machines Plant and Machinery
- DIN EN 60204.1, Equipment for Industrial Machines

Full technical documentation is available.

**Commissioning of the OSP-E is forbidden until it has been established that the machine/plant in which it is to be installed complies with the requirements of the EU Machines Directives.**

Filderstadt, august 2006

Johann Asperger  
Managing Director

Dr. Robert Eschmann  
Dep. for Research and Development

## 11 Spare part lists

### 11.1 OSP-E..BHD

**BHDII: Linear drive with toothed belt and integrated recirculating ball bearing guide**

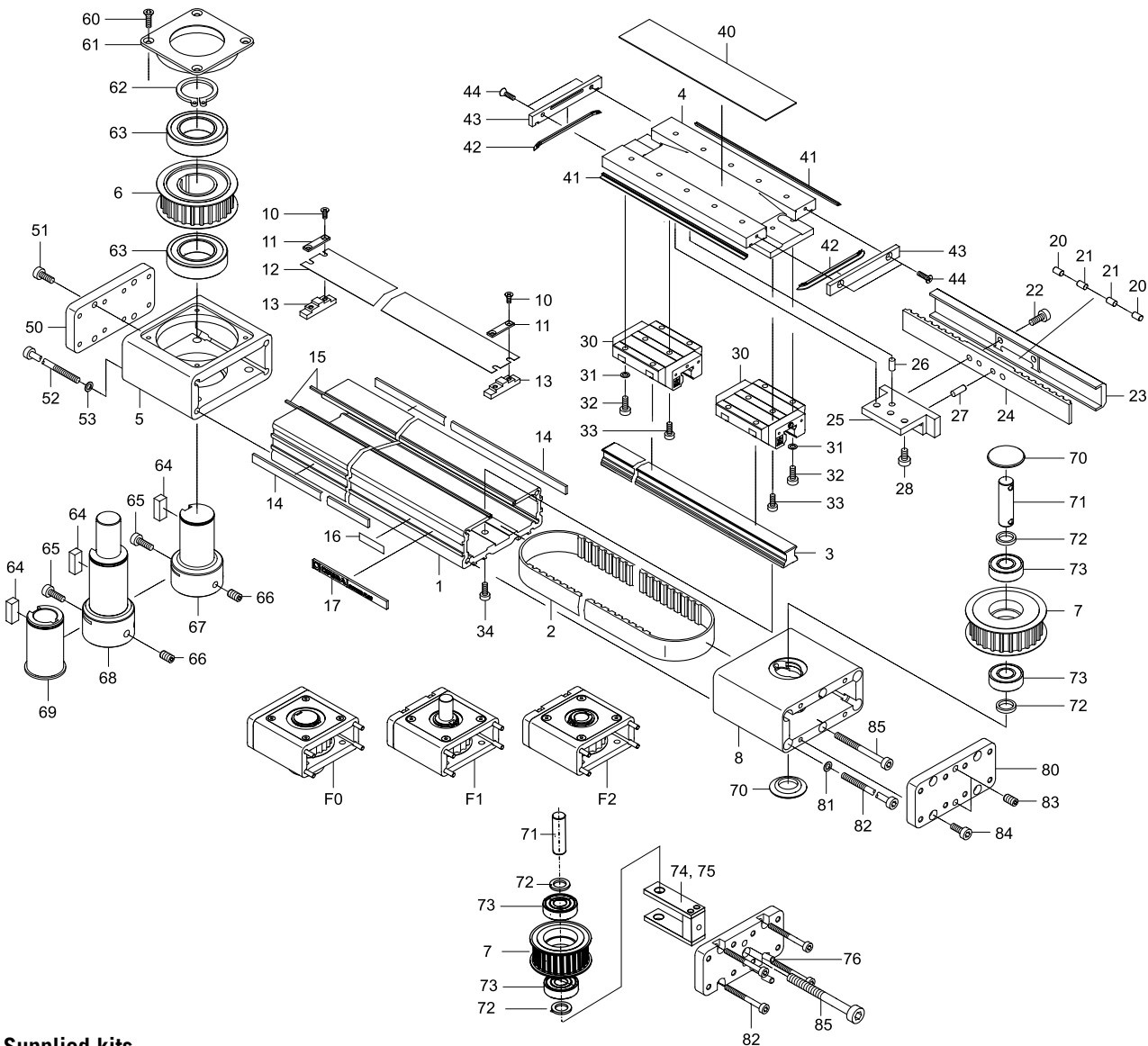

#### Supplied kits

Description	Order No.				Contents
	OSP-E20BHD	OSP-E25BHD	OSP-E32BHD	OSP-E50BHD	
Service kit	16317	15266	15267	15268	2, 10, 11, 12, 13, 70
Outer-band-kit	16316	15271	15272	15273	10, 11, 12, 13
End cap kit - run end	16145	12930	12931	12932	7, 70, 71, 72, 73, 8, 80, 81, 82, 83, 84, 85
End cap kit - drive clamp shaft	16144	12927	12928	12929	5, 50, 51, 52, 53, 6, 60, 61, 62, 63, 64, 65, 66, 67
End cap kit - drive clamp shaft and plain shaft	16148	15093	15095	15097	5, 50, 51, 52, 53, 6, 60, 61, 62, 63, 64, 65, 66, 68
End cap kit - plain shaft	16185	16318	16319	16320	5,50,51,52,53,6,60,61,62,63,64,90
End cap kit - drive hollow shaft	16147	15094	15096	15098	5, 50, 51, 52, 53, 6, 60, 61, 62, 63, 64, 65, 66, 69



POS.	DESCRIPTION	POS.	DESCRIPTION
1	CYLINDER BARREL OSP-E..BHD	44	COUNTERSUNK SCREW DIN 7991
2	TOOTH BELT OSP-E..BHD	50	COVER PLATE ACTUATOR FOR OSP-E..BHD
3	GUIDE RAIL OSP-E..BHD	51	SOCKET HEAD CAP SCREW DIN 912
4	CARRIER OSP-E..BHD	52	SOCKET HEAD CAP SCREW DIN 912
5	CAP ACTUATOR OSP-E..BHD	53	WASHER
6	TOOTH BELT WHEEL ACTUATOR OSP-E..BHD	60	COUNTERSUNK SCREW DIN 7991
7	TOOTH BELT WHEEL CIRCULATION OSP-E..BHD	61	COVER CAP ACTUATOR OSP-E..BHD
8	END CAP RUN END OSP-E..BHD	62	WASHER DIN 471
10	COUNTERSUNK SCREW DIN 7991	63	BALL BEARING
11	CLAMPING PIECE FOR OUTER BAND OSP-E..BHD	64	KEY DIN 6885
12	OUTER BAND OSP-E..BHD	65	SOCKET HEAD CAP SCREW DIN 912
13	CLAMPING PIECE FOR INNER BAND OSP-E..BHD-II	66	SOCKET SET SCREW DIN 913
14	COVER RAIL	67	CLAMP SHAFT
15	MAGNETIC STRIP	68	CLAMP SHAFT WITH PLAIN SHAFT
16	IDENTIFICATION PLATE	69	HOLLOW SHAFT WITH KEYWAY
17	COVER RAIL- LABEL	70	COVER CAP (NOT OSP-E20BHD)
20	STEEL BOLT (2*OSP-E20BHD, 25BHD, 32BHD / 3*OSP-E50BHD)	71	AXLE CIRCULATION OSP-E..BHD
21	MAGNET (1*OSP-E20BHD / 6*OSP-E25BHD / 2*OSP-E32BHD / 3*OSP-E50BHD)	72	DISTANCE RING OSP-E..BHD
22	SOCKET HEAD CAP SCREW DIN 6912	73	BALL BEARING
23	CLAMPING PLATE OSP-E..BHD	80	COVER PLATE CIRCULATION OSP-E..BHD
24	TOOTH BELT KEYLOCK OSP-E..BHD	81	WASHER
25	TOOTH BELT SHACKLE PLATE OSP-E..BHD-II	82	SOCKET HEAD CAP SCREW DIN 912
26	ROLL PIN DIN 6325 ONLY OSP-E32BHD AND OSP-E50BHD	83	SOCKET SET SCREW DIN 913
27	ROLL PIN DIN 7	84	SOCKET HEAD CAP SCREW DIN 912
28	SOCKET HEAD CAP SCREW DIN 7984	85	SOCKET HEAD CAP SCREW DIN 912
30	GUIDED CARRIAGE OSP-E..BHD		
31	WASHER		
32	SOCKET HEAD CAP SCREW DIN 912		
33	SOCKET HEAD CAP SCREW DIN 7984		
34	SOCKET HEAD CAP SCREW DIN 7984		
40	COVER OSP-E..BHD		
41	SIDE WIPER		
42	WIPER GABLE END		
43	WIPER COVER		

# Modular electrical linear drives OSP-E

## 11.2 OSP-E..BHD

**BHD: Linear drive with toothed belt and integrated roller guide**

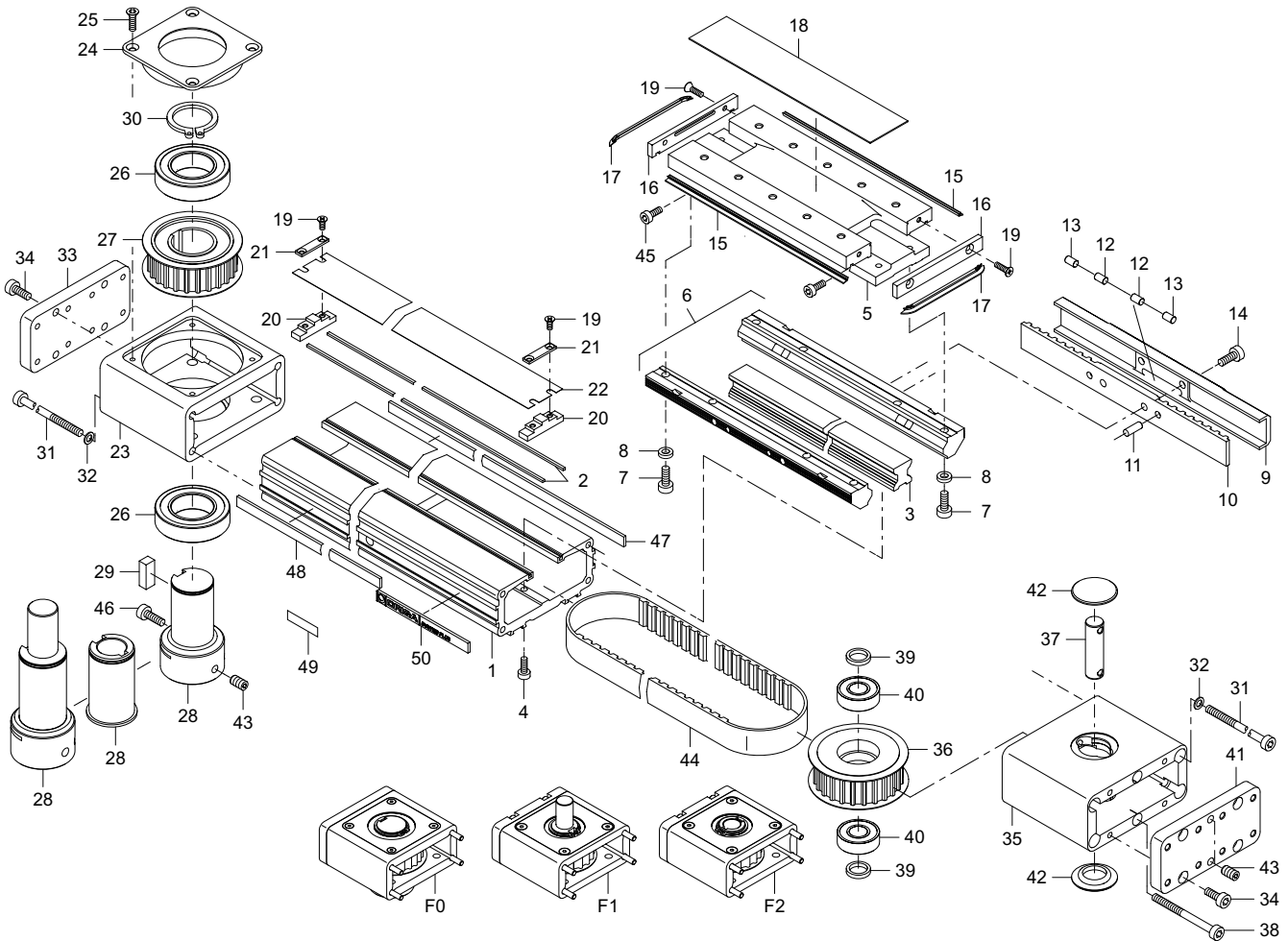

### Supplied kits

Description	Order No.			Contents
	OSP-E25BHD	OSP-E32BHD	OSP-E50BHD	
Service kit	15266	15267	15268	19, 20, 21, 22, 42, 44
Outer-band-kit	15271	15272	15273	19, 20, 21, 22
End cap kit - run end	12930	12931	12932	31, 32, 34, 35, 36, 37, 38, 39, 40, 41, 42, 43
End cap kit - drive clamp shaft	12927	12928	12929	23, 24, 25, 26, 27, 28, 29, 30, 31, 32, 33, 34, 43, 46
End cap kit - clamp shaft with plain shaft	15093	15095	15097	23, 24, 25, 26, 27, 28, 29, 30, 31, 32, 33, 34, 43, 46
End cap kit - drive plain	16318	16319	16320	5,50,51,52,53,6,60,61,62,63,64,90
End cap kit - drive hollow shaft	15094	15096	15098	23, 24, 25, 26, 27, 28, 29, 30, 31,32, 33, 34

POS.	DESCRIPTION
1	CYLINDER BARREL OSP-E..BHD CUT TO LENGTH
2	MAGNET BAND
3	DOUBLE RAIL FD15K OSP-E..BHD CUT TO LENGTH
4	CYLINDER SCREW DIN 912
5	CARRIER OSP-E..BHD
6	ROLLER SHOE PAIR OSP-E..BHD
7	CYLINDER SCREW DIN 912
8	LOCKING DISK
9	CLAMPING PLATE OSP-E..BHD
10	BELT LOCK OSP-E..BHD
11	CYLINDRICAL PIN DIN 7
12	MAGNET
13	STEEL BOLT OSP-E32BHD / OSP-E50BHD
14	CYLINDER SCREW DIN 6912
15	WIPER SIDE OSP-E..BHD CUT TO LENGTH
16	WIPER COVER OSP-E..BHD
17	WIPER END OSP-E..BHD CUT TO LENGTH
18	COVERING OSP-E..BHD
19	COUNTERSUNK SCREW DIN 7991
20	CLAMPING PIECE INTERN OSP-E..BHD
21	CLAMPING PIECE OUTER BAND OSP-E..BHD
22	OUTER BAND CUT TO LENGTH OSP-E..BHD
23	COVER DRIVE FOR OSP-E..BHD CLAMP SHAFT
24	COVERING COVER DRIVE OSP-E..BHD
25	COUNTERSUNK SCREW DIN 7991
26	BALL BEARING
27	BELT WHEEL DRIVE FOR OSP-E..BHD
28	CLAMP SHAFT OSP-E..BHD / HOLLOW SHAFT
29	ADJUSTING SPRING DIN 6885
30	LOCKING DISK DIN 471

POS.	DESCRIPTION
31	CYLINDER SCREW DIN 912
32	LOCKING DISK
33	COVER PLATE DRIVE FOR OSP-E..BHD KL.
34	CYLINDER SCREW DIN 912
35	COVER REVERSE GUIDE OSP-E..BHD
36	BELT WHEEL REVERSE GUIDE FOR OSP-E..BHD
37	AXLE REVERSE GUIDE FOR OSP-E..BHD
38	CYL. SCREW DIN 912
39	DISTANCE RING FOR OSP-E..BHD
40	BALL BEARING
41	COVER PLATE REVERSE GUIDE FOR OSP-E..BHD
42	COVER CAP
43	THREADED PIN DIN 916
44	BELT OSP-E..BHD CUT TO LENGTH
45	CYLINDER SCREW DIN 7984
46	CYLINDER SCREW DIN 912
47	COVER RAIL METER GOODS
48	COVER RAIL METER GOODS
49	IDENTIFICATION PLATE
50	COVER RAIL FOR NAMEPLATE

## 11.3 OSP-E..BV

Vertical linear drive with tooth belt and integrated recirculating ball bearing guide

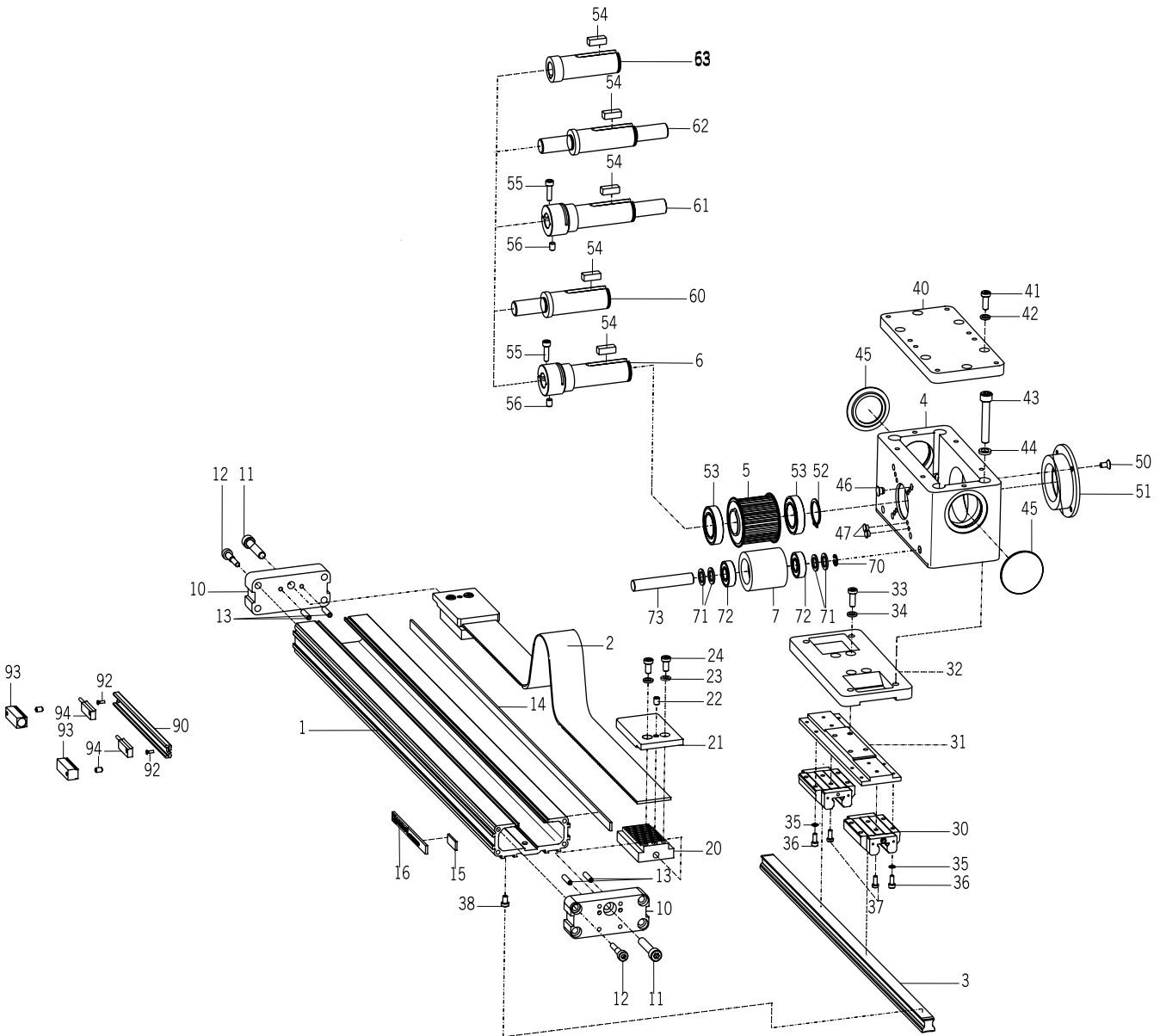

POS.	DESCRIPTION	POS	DESCRIPTION
1	CYLINDER BARREL OSP-E..BV	42	LOCK WASHER
2	TOOTHED BELT OSP-E..BV	43	SOCKET HEAD CAP SCREW DIN 912
3	GUIDE RAIL OSP-E..BV	44	LOCK WASHER
4	CAP ACTUATOR OSP-E..BV	45	COVER CAP GPN 910/4010
5	TOOTHED BELT DRIVE OSP-E..BV	46	PLUG 7 D
6	CLAMP SHAFT	47	PLUG M6
7	TOOTH BELT WHEEL CIRCULATION OSP-E..BV	50	COUNTERSUNK SCREW DIN 7991
10	COVER PLATE OSP-E..BV	51	COVER CAP ACTUATOR OSP-E..BV
11	SOCKET HEAD CAP SCREW DIN 912	52	LOCK WASHER DIN 471
12	SCREW FOR COVER	53	BALL BEARING
13	SOCKET SET SCREW DIN 916	54	KEYWAY
14	COVER RAIL	55	SOCKET HEAD CAP SCREW DIN 912
15	IDENTIFICATION PLATE	56	SOCKET SET SCREW DIN 913
16	COVER RAIL IDENTIFICATION PLATE	60	SHAFT WITH PLAIN
20	BELT LOCK OSP-E..BV	61	CLAMP SHAFT WITH PLAIN SHAFT
21	CLAMPING PLATE OSP-E..BV	62	CLAMP SHAFT WITH PLAIN SHAFT DOUBLE SIDED
22	CYLINDRICAL PIN DIN 6325	63	HOLLOW SHAFT WITH KEYWAY
24	SOCKET HEAD CAP SCREW DIN 7984	70	LOCK WASHER DIN 472
30	GUIDED CARRIAGE OSP-E..BV	71	DISTANCE RING
31	CARRIER PLATE OSP-E..BV	72	BALL BEARING
32	COVER PLATE OSP-E..BV	73	KEEPER
33	SOCKET HEAD CAP SCREW DIN 7984	90	LOCK RAIL
34	LOCK WASHER	92	SOCKET HEAD CAP SCREW
35	LOCK WASHER	93	MAGNET
36	SOCKET HEAD CAP SCREW DIN 912	94	KL3087 (RS-S NC)
37	SOCKET HEAD CAP SCREW DIN 6912		
38	SOCKET HEAD CAP SCREW DIN 7984		
40	COVER PLATE DRIVE OSP-E..BV		
41	SOCKET HEAD CAP SCREW DIN 7984		

## 11.4 OSP-E..B

### Linear Drive with toothed belt and internal plain bearing guide

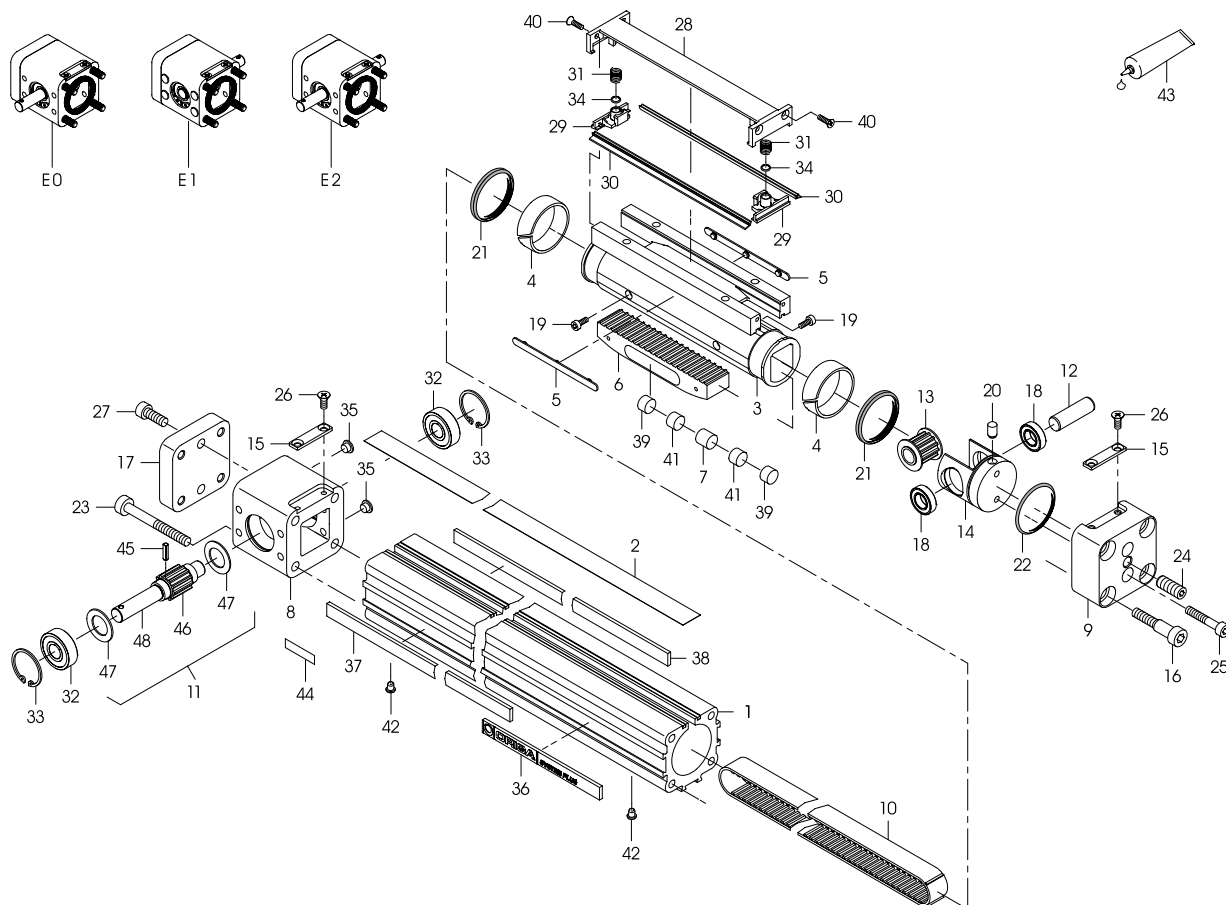

### Supplied kits

Description	Order No.			Contents
	OSP-E25B	OSP-E32B	OSP-E50B	
Seal kit	12110	12111	12112	4, 5, 19, 21, 22, 28, 29, 30, 31, 34, 40, 43
Service kit	15247	15248	15249	Seal kit + 2, 10
Carrier kit	12172	12173	12174	3, 4, 5, 6, 7, 19, 28, 29, 30, 31, 34, 39, 40, 41
End cap kit running unit	12113	12117	12121	9, 12, 13, 14, 15, 16, 18, 20, 21, 22, 24, 25, 26
End cap kit shaft 0	12114 / 15277*	12118 / 15280*	12122 / 15283*	8, 15, 17, 21, 23, 26, 27, 32, 33, 35, 45, 46, 47, 48
End cap kit shaft 1	12115 / 15278*	12119 / 15281*	12123 / 15284*	8, 15, 17, 21, 23, 26, 27, 32, 33, 35, 45, 46, 47, 48
End cap kit shaft 2	12116 / 15279*	12120 / 15282*	12124 / 15285*	8, 15, 17, 21, 23, 26, 27, 32, 33, 35, 45, 46, 47, 48

\*) Stainless steel version

POS.	DESCRIPTION	POS.	DESCRIPTION
1	CYLINDER BARREL OSP-E..B CUT TO LENGTH	30	SIDE WIPER CUT TO LENGTH ON SIDE
2	OUTER BAND CUT TO LENGTH OSP-E..B	31	THRUST SPRING FOR WIPER
3	CARRIER OSP-E..B	32	BALL BEARING
4	SUPPORT RING OSP-E..B	33	CIRCLIP DIN 472
5	BEARING STRIP OSP-E..B	34	O-RING
6	MAGNET HOUSING FOR OSP-E..B	35	PLUG PLASTIC FOR SECURING BOREHOLES
7	MAGNET 10D X 3L FOR OSP-E..B	36	COVER RAIL FOR NAMEPLATE
8	DRIVE END CAP FOR OSP-E..B	37	COVER RAIL METER GOODS
9	RUN END CAP FOR OSP-E..B	38	COVER RAIL METER GOODS
10	BELT OSP-E..B CUT TO LENGTH	39	BOLT FOR MAGNET
11	SHAFT ONE-SIDE OSP-E32B / OSP-E50B	40	COUNTERSUNK SCREW DIN 7991
12	AXLE REVERSE GUIDE FOR OSP-E..B	41	MAGNET OSP-E32B
13	BELT WHEEL REVERSE GUIDE FOR OSP-E..B	42	GREASE NIPPLE A1
14	BEARING HOUSING FOR OSP-E..B	43	GREASE FOR GUIDE
15	CLAMPING PIECE EXTERN	44	IDENTIFICATION PLATE OSP
16	SCREW FOR COVER	45	BRACING PIN DIN 7343 OSP-E25B
17	COVER PLATE FOR OSP-E..B	46	BELT WHEEL DRIVE FOR OSP-E25B
18	BALL BEARING	47	DISTANCE RING FOR OSP-E25B
19	CYLINDER SCREW	48	SHAFT ONE SIDE OSP-E25B
20	CYLINDRICAL PIN DIN 6325		
21	X-RING		
22	O-RING		
23	CYLINDER SCREW DIN 912		
24	THREADED PIN DIN 916		
25	CYLINDER SCREW DIN 912		
26	COUNTERSUNK SCREW DIN 963		
27	CYLINDER SCREW DIN 912		
28	COVER		
29	WIPER		

## 11.5 OSP-E..B

Linear Drive with toothed belt and internal plain bearing guide

Bi-Parting version

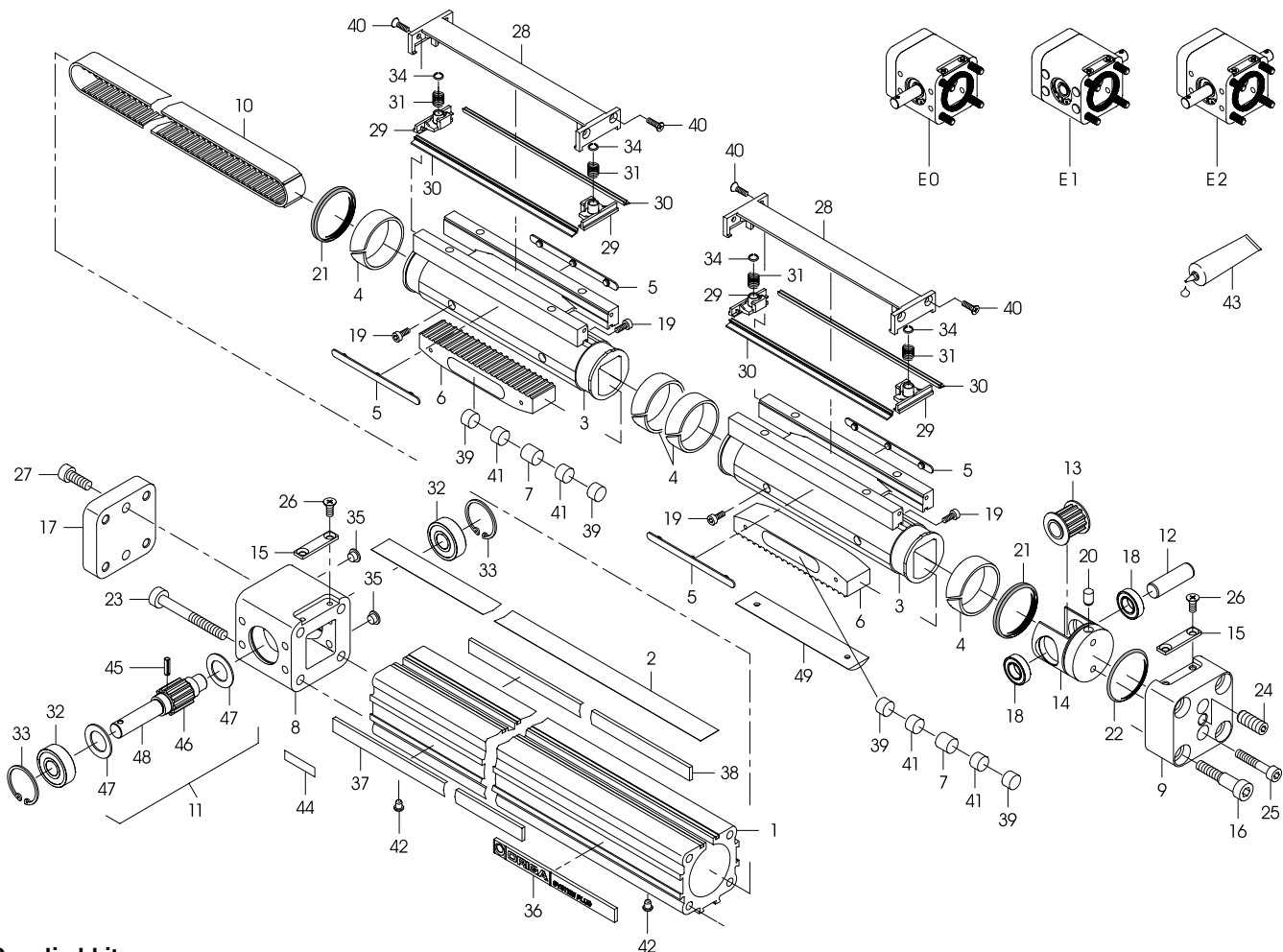

### Supplied kits

Description	Order No.			Contents
	OSP-E25BP	OSP-E32BP	OSP-E50BP	
Seal kit	2 x 12110	2 x 12111	2 x 12112	4, 5, 19, 21, 22, 28, 29, 30, 31, 34, 40, 43
Service kit	15289	15290	15291	Seal kit + 2, 10
Carrier kit	15253	15254	15255	3, 4, 5, 6, 7, 19, 28, 29, 30, 31, 34, 36, 40, 41, 49
End cap kit running unit	12113	12117	12121	9, 12, 13, 14, 15, 16, 18, 20, 21, 22, 24, 25, 26
End cap kit shaft 0	12114 / 15277*	12118 / 15280*	12122 / 15283*	8, 15, 17, 21, 23, 26, 27, 32, 33, 35, 45, 46, 47, 48
End cap kit shaft 1	12115 / 15278*	12119 / 15281*	12123 / 15284*	8, 15, 17, 21, 23, 26, 27, 32, 33, 35, 45, 46, 47, 48
End cap kit shaft 2	12116 / 15279*	12120 / 15282*	12124 / 15285*	8, 15, 17, 21, 23, 26, 27, 32, 33, 35, 45, 46, 47, 48

\*] Stainless steel version



POS.	DESCRIPTION	POS.	DESCRIPTION
1	CYLINDER BARREL OSP-E..BP CUT TO LENGTH	30	WIPER CUT TO LENGTH ON SIDE
2	OUTER BAND CUT TO LENGTH OSP-E..BP	31	SPRING
3	CARRIER OSP-E..BP	32	BALL BEARING
4	SUPPORT RING OSP-E..BP	33	CIRCLIP DIN 472
5	BEARING STRIP OSP-E..BP	34	O-RING
6	MAGNET HOUSING FOR OSP-E..BP	35	PLUG PLASTIC FOR SECURING BOREHOLES
7	MAGNET 10D X 3L FOR OSP-E..BP	36	COVER RAIL FOR NAMEPLATE
8	DRIVE END CAP FOR OSP-E..BP	37	COVER RAIL METER GOODS
9	RUN END CAP FOR OSP-E..BP	38	COVER RAIL METER GOODS
10	BELT OSP-E..B CUT TO LENGTH	39	BOLT FOR MAGNET OSP-E..BP
11	SHAFT ONE SIDE OSP-E32B / OSP-E50BP	40	COUNTERSUNK SCREW DIN 7991
12	AXLE REVERSE GUIDE FOR OSP-E..B	41	MAGNET OSP-E32BPP
13	BELT WHEEL REVERSE GUIDE FOR OSP-E..BP	42	GREASE NIPPLE A1
14	BEARING HOUSING FOR OSP-E..BP	43	GREASE FOR GUIDE
15	CLAMPING PIECE EXTERN	44	IDENTIFICATION PLATE OSP
16	SCREW FOR COVER	45	LOCK PIN DIN 7343 FOR OSP-E25BP
17	COVER PLATE FOR OSP-E..BP	46	WHEEL BELT DRIVE FOR OSP-E25BP
18	BALL BEARING	47	DISTANCE RING FOR OSP-E25BP
19	CYLINDER SCREW DIN 912	48	SHAFT ONE SIDE OSP-E25BP
20	CYLINDRICAL PIN DIN 6325	49	FILLING OUT PLATE FOR OSP-E..BP
21	X-RING		
22	O-RING		
23	CYLINDER SCREW DIN 912		
24	THREADED PIN DIN 916		
25	CYLINDER SCREW DIN 912		
26	COUNTERSUNK SCREW DIN 963		
27	CYLINDER SCREW DIN 912		
28	COVER		
29	WIPER		

# Modular electrical linear drives OSP-E

## 11.6 OSP-E..SB

### Linear drive with ball screw drive and internal plain bearing guide

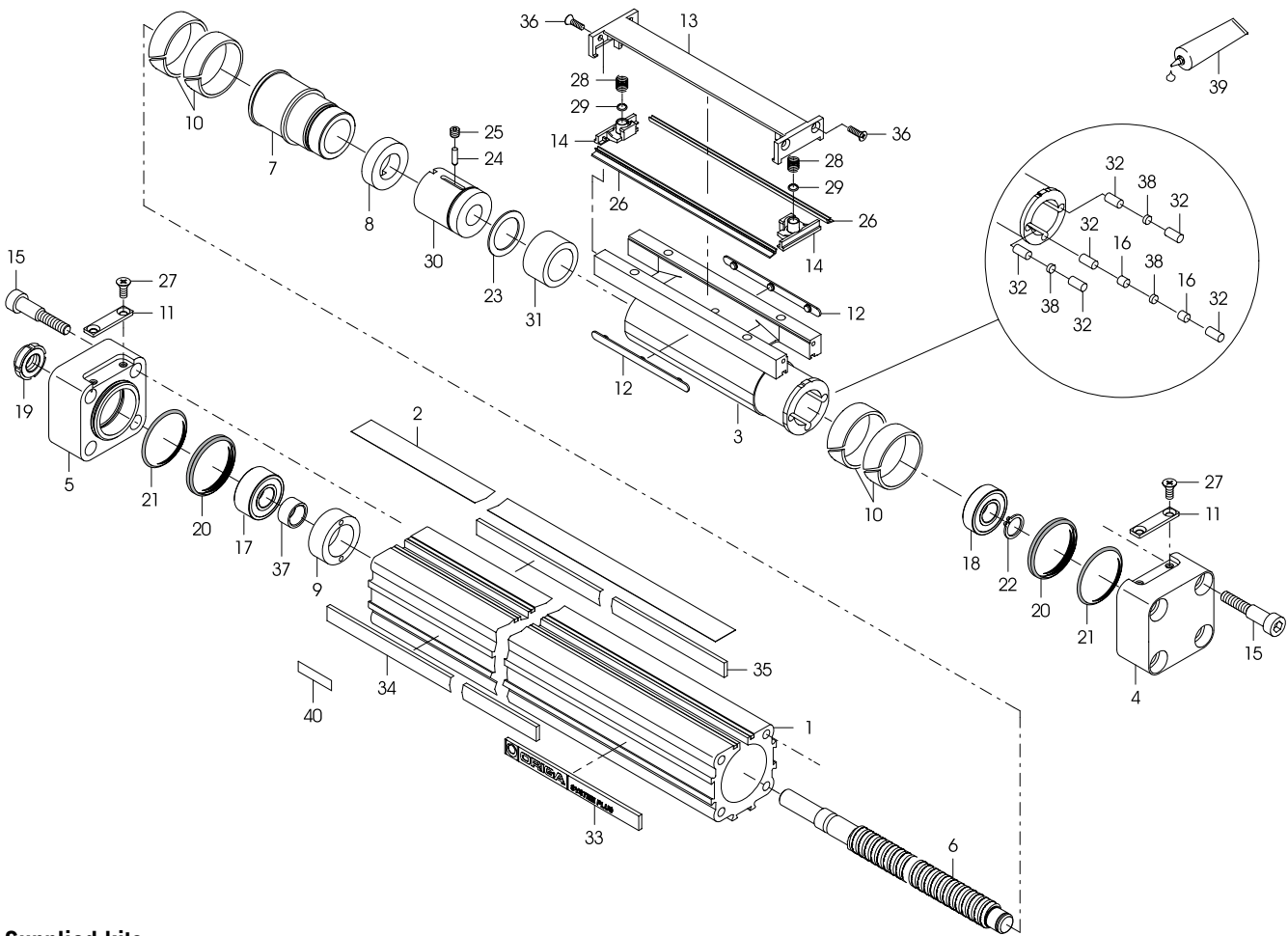

### Supplied kits

Description	Order No.			Contents
	OSP-E25S	OSP-E32S	OSP-E50S	
Seal kit	12125	12126	12127	10, 12, 13, 14, 20, 21, 26, 28, 29, 36, 39
Service pack	15250	15251	15252	Seal kit + 2
Carrier kit spindle 5 mm	12166	12168	12916	3, 7, 8, 10, 12, 13, 14, 16, 23, 24, 25, 26, 28, 29, 32, 36, 38
Carrier kit spindle 10 mm	-	12168	12916	3, 7, 8, 10, 12, 13, 14, 16, 23, 24, 25, 26, 28, 29, 32, 36, 38
Carrier kit spindle 25 mm	-	-	12916	3, 7, 8, 10, 12, 13, 14, 16, 23, 24, 25, 26, 28, 29, 32, 36, 38
Carrier kit spindle 50 mm	-	-	12916	3, 7, 8, 10, 12, 13, 14, 16, 23, 24, 25, 26, 28, 29, 32, 36, 38
Ball Screw Drive 5 mm	15256	15257	15259	6, 30
Ball Screw Drive 10 mm	-	15258	15260	6, 30
Ball Screw Drive 25 mm	-	-	15261	6, 30
Ball Screw Drive 50 mm	-	-	15262	6, 30
End cap kit run unit spindle	12129	12131	12133	4, 11, 15, 18, 20, 21, 22, 27
End cap kit actuator spindle	12128	12130	12132	5, 9, 11, 15, 17, 20, 21, 27

POS.	DESCRIPTION
1	CYLINDER BARREL CUT TO LENGTH OSP-E..S
2	OUTER BAND CUT TO LENGTH OSP-E..S
3	CARRIER OSP-E..S
4	END CAP FOR OSP-E..S
5	END CAP DRIVE FOR OSP-E..S
6	BALL THREADED SPINDLE
7	LOCKING NUT OSP-E..S
8	ADJUSTING NUT OSP-E..S
9	CLAMPING RING OSP-E..S
10	SUPPORT RING OSP-E..S
11	CLAMPING PIECE EXTERN
12	BEARING STRIPS OSP-E..S
13	COVER
14	WIPER
15	SCREW FOR COVER
16	MAGNET OSP-E..S
17	BALL BEARING
18	BALL BEARING
19	NUT
20	X-RING
21	O-RING
22	CIRCLIP DIN 471
23	FITTING DISK DIN 988

POS.	DESCRIPTION
24	NEEDLE ROLL NRB
25	THREADED PIN DIN 913
26	SIDE WIPER CUT TO LENGTH ON SIDE
27	COUNTERSUNK SCREW DIN 963
28	THRUST SPRING FOR WIPER
29	O-RING
30	BALL THREADED NUT FOR OSP-E..S
31	DISTANCE RING
32	STEEL BOLT
33	COVER RAIL FOR NAMEPLATE
34	COVER RAIL METER GOODS
35	COVER RAIL METER GOODS
36	COUNTERSUNK SCREW DIN 7991
37	SLEEVE
38	MAGNET
39	GREASE FOR GUIDE
40	IDENTIFICATION PLATE

## 11.7 OSP-E..ST

Linear drive with trapezoidal screw drive and internal plain bearing guide

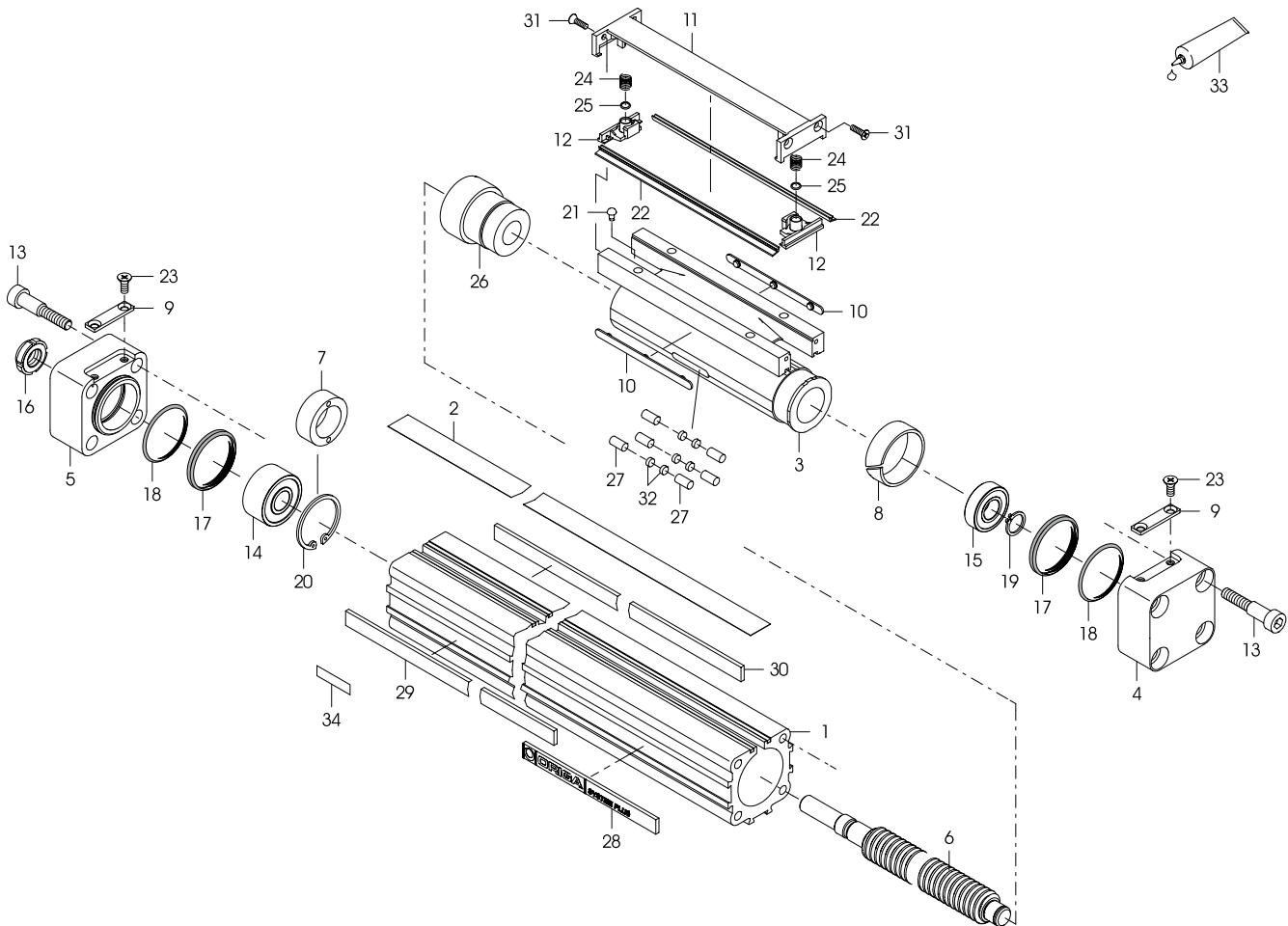

### Supplied kits

Description	Order No.			Contents
	OSP-E25ST	OSP-E32ST	OSP-E50ST	
Seal kit	12125	12126	12127	8, 10, 11, 12, 17, 18, 22, 24, 25, 31, 33
Service pack	15250	15251	15252	seal kit + 2
Carrier kit	12816	12825	12834	3, 8, 10, 11, 12, 21, 22, 24, 25, 26, 27, 31, 32
End cap kit run unit spindle	12129	12131	12133	4, 9, 13, 15, 17, 18, 19, 23
End cap kit actuator spindle	12128	15617	15618	5, 9, 13, 14, 17, 18, 20, 23

POS.	DESCRIPTION
1	CYLINDER BARREL CUT TO LENGTH OSP-E..ST
2	OUTER BAND CUT TO LENGTH OSP-E..ST
3	CARRIER OSP-E..ST
4	END CAP FOR OSP-E..ST
5	END CAP DRIVE FOR OSP-E..ST
6	TRAPEZOIDAL THREADED SPINDLE OSP-E..ST CUT TO LENGTH
7	CLAMPING RING OSP-E25ST
8	SUPPORT RING OSP-E..ST
9	CLAMPING PIECE EXTERN
10	SLIDE RAIL OSP-E..ST
11	COVER
12	WIPER
13	SCREW FOR COVER
14	BALL BEARING
15	BALL BEARING
16	NUT
17	X-RING
18	O-RING
19	CIRCLIP DIN 471
20	CIRCLIP OSP-E32ST / OSP-E50ST

POS.	DESCRIPTION
21	SCREW
22	SIDE WIPER CUT TO LENGTH ON SIDE
23	COUNTERSUNK SCREW DIN 963
24	THRUST SPRING FOR WIPER
25	O-RING
26	TRAPEZOIDAL THREADED NUT FOR OSP-E..ST
27	STEEL BOLT
28	COVER RAIL FOR NAMEPLATE
29	COVER RAIL METER GOODS
30	COVER RAIL METER GOODS
31	COUNTERSUNK SCREW DIN 7991
32	MAGNET FOR OSP-E..ST
33	GREASE
34	IDENTIFICATION PLATE

## 11.8 OSP-E..SB

### Linear drive with ball screw drive and internal plain bearing guide

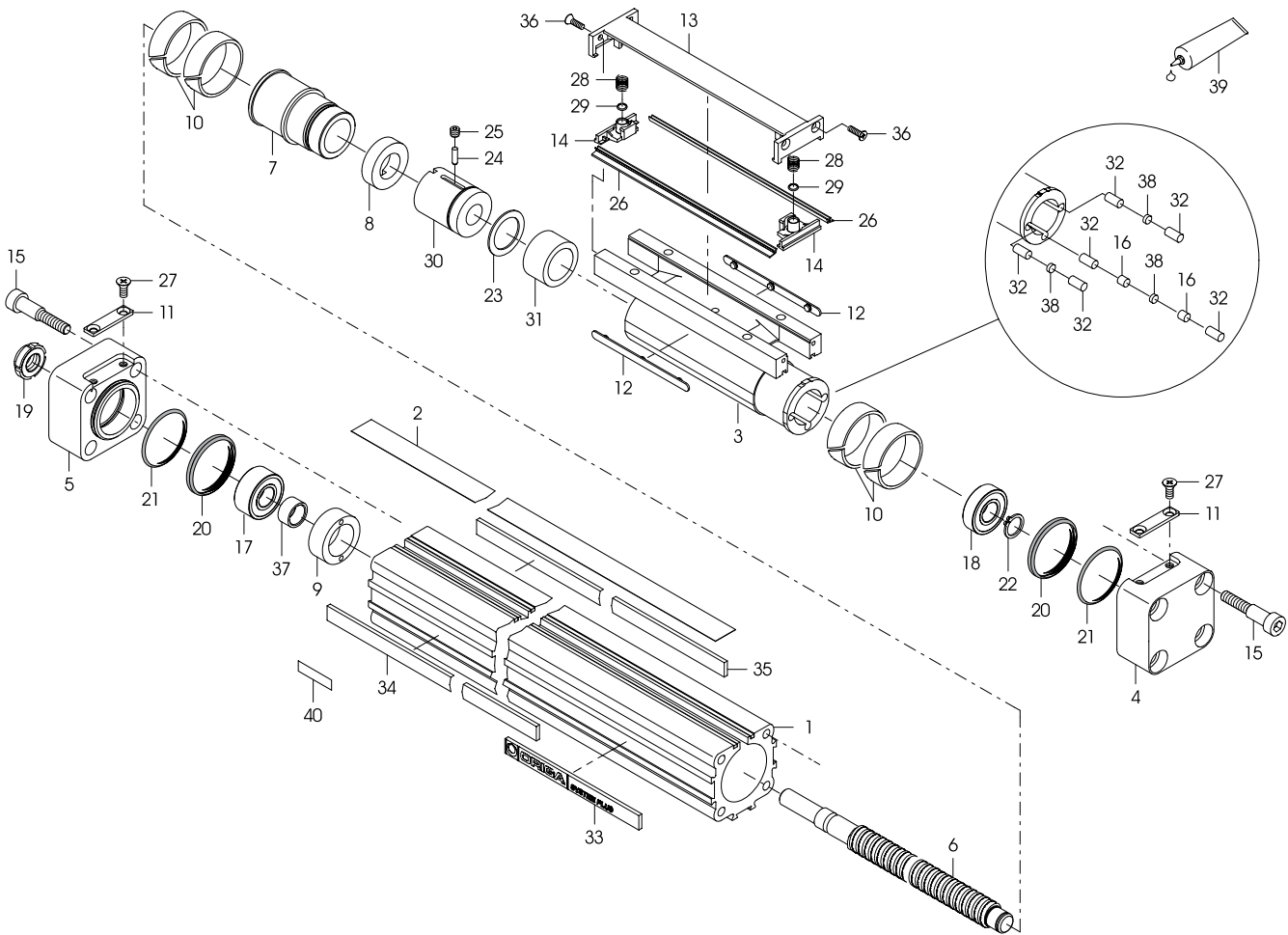

POS.	DESCRIPTION
1	CYLINDER BARREL OSP-E..SBR CUT TO LENGTH
2	BALL SCREW
3	PISTON ROD
4	SUPPORT RING OSP-E..SBR
5	BALL SCREW NUT
6	ADJUSTING NUT
7	END CAP DRIVE FOR OSP-E..SBR
8	END CAP PISTON SIDE OSP-E..SBR
9	COUNTERSUNK SCREW DIN 965
10	CLAMPING PIECE EXTERN
11	SCREW FOR COVER
12	LOCKING NUT
13	BALL BEARING
14	SLEEVE OSP-E32SBR
15	CLAMPING RING
16	O-RING
17	X-RING
18	WIPER
19	SEALING RING DIN 471
20	SUPPORT BEARING
21	SLIDE BEARING
22	PISTON ROD SECUREMENT
23	COVER RAIL FOR NAMEPLATE

POS.	DESCRIPTION
24	IDENTIFICATION PLATE
25	COVER RAIL METER GOODS
26	OUTER BAND CUT TO LENGTH
30	NUT SLEEVE
31	BEARING STRIPL
32	COUNTERSUNK SCREW DIN 965
33	TURNING LOCK
34	SOCKET SET SCREW DIN 914
35	SOCKET SET SCREW DIN 916
40	MAGNET HOLDER OSP-E32/50SBR
41	STEEL BOLT OSP-E32/50SBR
42	MAGNET OSP-E32/50SBR
43	MAGNET OSP-E32SBR
50	MAGNET OSP-E25SBR
51	ADJUSTING WASHER OSP-E25SBR
52	SEALING RING DIN 471 OSP-E25SBR
99	PARKER-ORIGA GREASE 2

## 11.9 OSP-E..STR

Linear drive with trapezoidal screw drive, internal plain bearing guide and piston rod

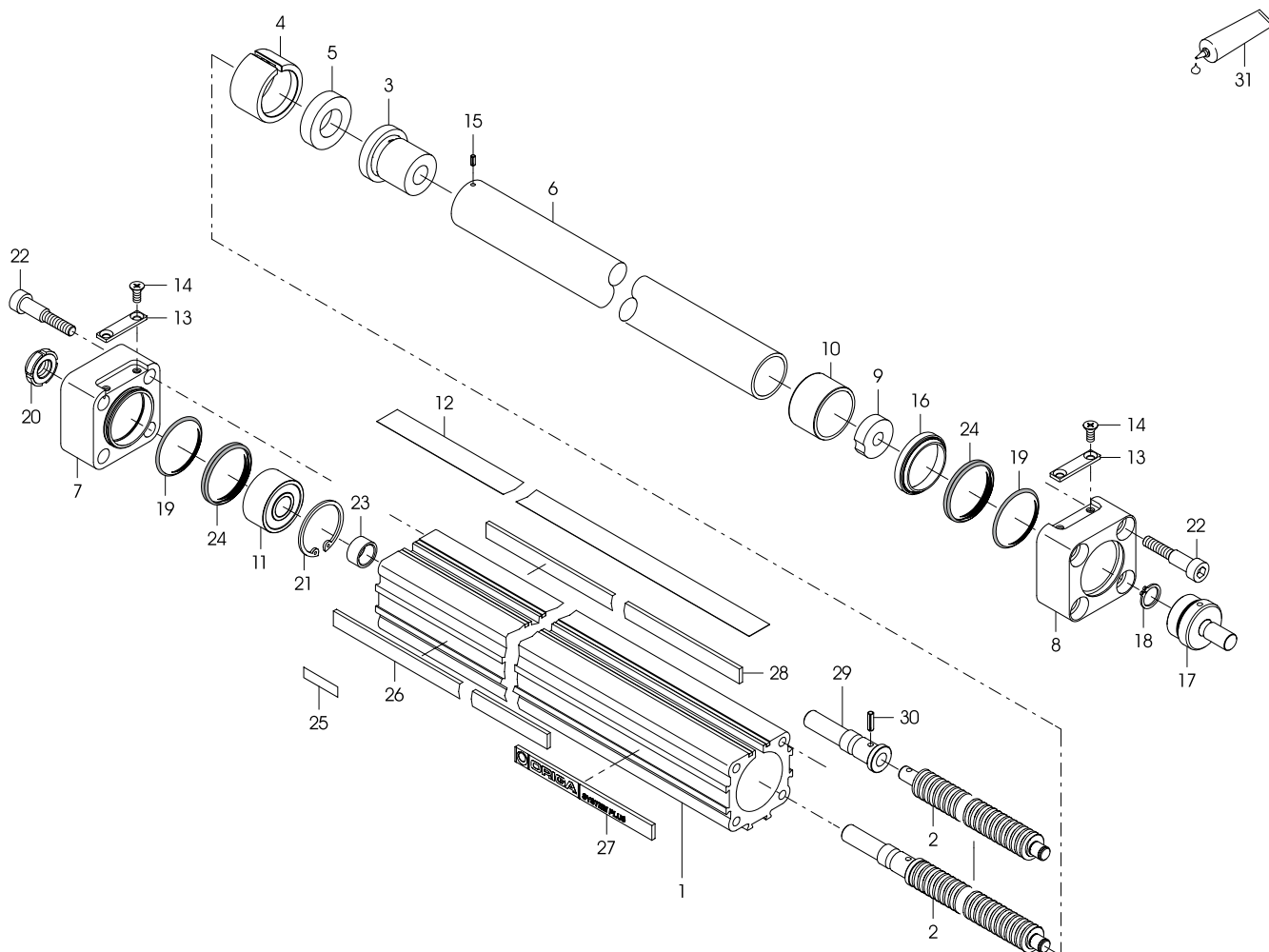

### POS. DESCRIPTION

1	CYLINDER BARREL OSP-E..SR CUT TO LENGTH
2	TRAPEZOIDAL THREADED SPINDLE OSP-E..ST CUT TO LENGTH
3	NUT TR16X4 OSP-E..SR
4	SUPPORT RING OSP-E..SR
5	MAGNET FOR OSP-E..SR
6	PISTON ROD OSP-E..SR CUT TO LENGTH
7	END CAP DRIVE FOR OSP-E..SR
8	END CAP PISTON SIDE OSP-E..SR
9	SUPPORT BEARING OSP-E..SR
10	SLIDE BEARING
11	BALL BEARING
12	OUTER BAND CUT TO LENGTH OSP-E..SR
13	CLAMPING PIECE EXTERN OSP-E..SR
14	COUNTERSUNK SCREW DIN 965
15	BRACING PIN DIN 8752
16	WIPER
17	PISTON ROD SECUREMENT OSP-OSP-E..SR
18	CIRCLIP DIN 471

### POS. DESCRIPTION

19	O-RING
20	LOCKING NUT
21	CIRCLIP DIN 472
22	SCREW FOR COVER
23	SLEEVE FOR OSP-E32SR
24	X-RING
25	IDENTIFICATION PLATE
26	COVER RAIL METER GOODS
27	COVER RAIL FOR NAMEPLATE
28	COVER RAIL METER GOODS
29	SHAFT OSP-E32SR
30	BRACING PIN DIN 8752 OSP-E32SR
31	GREASE

# Sales Offices Worldwide Your competent partner with global service

## and distribution.

**AE – United Arab Emirates**  
Dubai

Tel: +971 4 8875600  
parker.me@parker.com

**AR – Argentina**, Buenos Aires  
Tel: +54 3327 44 4129

**AT – Austria**, Wiener Neustadt  
Tel: +43 (0)2622 23501-0  
parker.austria@parker.com

**AT – Austria**, Wiener Neustadt  
(Europa Oriental)  
Tel: +43 (0)2622 23501 970  
parker.easteurope@parker.com

**AT – Austria**, Wiener Neustadt  
Parker Origa Pneumatik GmbH  
Tel: +43 2622 26071-269  
info-hoat-sales.pn@parker-origa.com

**AU – Australia**, Castle Hill  
Tel: +61 (0)2-9634 7777

**AZ – Azerbaijan**, Baku  
Tel: +994 50 2233 458  
parker.azerbaijan@parker.com

**BE/LX – Belgium**, Nivelles  
Tel: +32 (0)67 280 900  
parker.belgium@parker.com

**BR – Brazil**, Cachoeirinha RS  
Tel: +55 51 3470 9144

**BY – Belarus**, Minsk  
Tel: +375 17 209 9399  
parker.belarus@parker.com

**CA – Canada**, Milton, Ontario  
Tel: +1 905 693 3000

**CH – Swiss**, Etoy  
Tel: +41 (0) 21 821 02 30  
parker.switzerland@parker.com

**CH – Swiss**, Otelfingen  
Parker Origa AG  
Tel: +41 44 846 6860  
info-hoch-sales@parker-origa.com

**CN – China**, Shanghai  
Tel: +86 21 5031 2525

**CZ – Czechia**, Klecany  
Tel: +420 284 083 111  
parker.czechrepublic@parker.com

**DE – Germany**, Kaarst  
Tel: +49 (0)2131 4016 0  
parker.germany@parker.com

**DK – Denmark**, Ballerup  
Tel: +45 43 56 04 00  
parker.denmark@parker.com

**ES – Spain**, Madrid  
Tel: +34 902 33 00 01  
parker.spain@parker.com

**FI – Finland**, Vantaa  
Tel: +358 (0)20 753 2500  
parker.finland@parker.com

**FR – France**  
Tel: +33 (0)4 50 25 80 25  
parker.france@parker.com

**FR – France**, Courtaboeuf Cedex  
Parker Origa SAS  
Tel: +33 1 69 29 22 00  
info-hofr-sales@parker-origa.com

**GR – Greece**, Atenas  
Tel: +30 210 933 6450  
parker.greece@parker.com

**HK – Hong Kong**  
Tel: +852 2428 8008

**HU – Hungary**, Budapest  
Tel: +36 1 220 4155  
parker.hungary@parker.com

**IE – Ireland**, Dublin  
Tel: +353 (0)1 466 6370  
parker.ireland@parker.com

**IN – India**, Mumbai  
Tel: +91 22 6513 7081-85

**IT – Italy**, Corsico (MI)  
Tel: +39 02 45 19 21  
parker.italy@parker.com

**IT – Italy**, Pioltello (MI)  
Parker Origa SRL  
Tel: +39 02 92 16 65 53  
info-hoit-sales@parker-origa.com

**JP – Japan**, Fujisawa  
Tel: +(81) 4 6635 3050

**KR – Korea**, Seúl  
Tel: +82 2 559 0400

**KZ – Kazakhstan**, Almaty  
Tel: +7 7272 505 800  
parker.easteurope@parker.com

**LV – Latvia**, Riga  
Tel: +371 6 745 2601  
parker.latvia@parker.com

**MX – Mexico**, Apodaca  
Tel: +52 81 8156 6000

**MY – Malaysia**, Subang Jaya  
Tel: +60 3 5638 1476

**MY – Malaysia**, Penang  
Parker Origa Sdn Bhd  
Tel: +60 4 508 10 11  
info-hosg-sales@parker-origa.com

**NL – Netherlands**, Oldenzaal  
Tel: +31 (0)541 585 000  
parker.nl@parker.com

**NL – Netherlands**, SL Moerdijk  
Parker Origa B.V.  
Tel: +31 168 356 600  
info-honl-sales@parker-origa.com

**NO – Norway**, Ski  
Tel: +47 64 91 10 00  
parker.norway@parker.com

**NO – Norway**, Drammen  
Parker Origa AS  
Tel: +47 3 288 08 40  
info-hose-sales@parker-origa.com

**NZ – New Zealand**  
Mt Wellington  
Tel: +64 9 574 1744

**PL – Poland**, Varsovia  
Tel: +48 (0)22 573 24 00  
parker.poland@parker.com

**PT – Portugal**, Leca da Palmeira  
Tel: +351 22 999 7360  
parker.portugal@parker.com

**RO – Romania**, Bucarest  
Tel: +40 21 252 1382  
parker.romania@parker.com

**RU – Russia**, Moscow  
Tel: +7 495 645-2156  
parker.russia@parker.com

**SE – Sweden**, Spånga  
Tel: +46 (0)8 59 79 50 00  
parker.sweden@parker.com

**SE – Sweden**, Kungsör  
Parker Origa AB  
Tel: +46 227 411 00  
info-hose-sales@parker-origa.com

**SG – Singapor**  
Tel: +65 6887 6300

**SG – Singapor**  
Parker Origa PTE Ltd.  
Tel: +65 6483 2959  
info-hose-sales@parker-origa.com

**SK – Slovakia**, Banská Bystrica  
Tel: +421 484 162 252  
parker.slovakia@parker.com

**SI – Slovenia**, Novo Mesto  
Tel: +386 7 337 6650  
parker.slovenia@parker.com

**TH – Thailand**, Bangkok  
Tel: +662 717 8140

**TR – Turkey**, Istanbul  
Tel: +90 216 4997081  
parker.turkey@parker.com

**TW – Taiwan**, Taipei  
Tel: +886 2 2298 8987

**UA – Ukraine**, Kiev  
Tel: +380 44 494 2731  
parker.ukraine@parker.com

**UK – United Kingdom**, Gloucester  
Parker Origa Ltd.  
Tel: +44 8700 600655  
info-hogb-sales@parker-origa.com

**UK – United Kingdom**, Warwick  
Tel: +44 (0)1926 317 878  
parker.uk@parker.com

**US – United States of America**,  
Cleveland  
Tel: +1 216 896 3000

**US – United States of America**  
Parker Origa Corporation  
Tel: +1 630 871 830-0  
info-hous-sales@parker-origa.com

**VE – Venezuela**, Caracas  
Tel: +58 212 238 5422

**ZA – South Africa**,  
Kempton Park  
Tel: +27 (0)11 961 0700  
parker.southafrica@parker.com

**Parker-Origa GmbH**  
Industriestr. 8  
70794 Filderstadt, Deutschland  
Tel. +49 7185 17030  
Fax +49 7158 64870  
www.parker-origa.com

