



PARKER CALZONI Radial Piston Motor Type MRT, MRTE, MRTF



RCOe 2301/10.04

DENISON CALZONI

TABLE OF CONTENTS - MOTOR TYPE MRT - MRTE - MRTF

CONTENS	PAG.
TABLE OF CONTENTS	2
GENERAL CHARATERISTICS	3
FUNCTIONAL DESCRIPTION	4
TECHINICAL DATA	5
FLUID SELECTION	6
FLUSHING PROCEDURE	7
OPERATING DIAGRAM MOTOR TYPE MRT 7100 MRTF 8100 MRTE 8500	8
OPERATING DIAGRAM MOTOR TYPE MRT 9000 MRTF 9900 MRTE 10800	9
OPERATING DIAGRAM MOTOR TYPE MRT 14000 MRTF 15500 MRTE 16500	10
OPERATING DIAGRAM MOTOR TYPE MRT 17000 MRTF 18000 MRT 19500	11
OPERATING DIAGRAM MOTOR TYPE MRTE 20000 MRTF 21500 MRTE 23000	12
OPERATING DIAGRAM (RUNNING PRESSURE DIFFERENCE AT NO LOAD)	13-14
OPERATING DIAGRAM (MOTOR /PUMP: BOOST PRESSURE)	14-15
MOTOR DIMENSIONS	16-19
COMPONENTS FOR SPEED CONTROL	20-21
INSTALLATION NOTES	22
ORDERING CODE	23
SALES AND SERVICE LOCATIONS WORLDWIDE	24

GENERAL CHARACTERISTICS

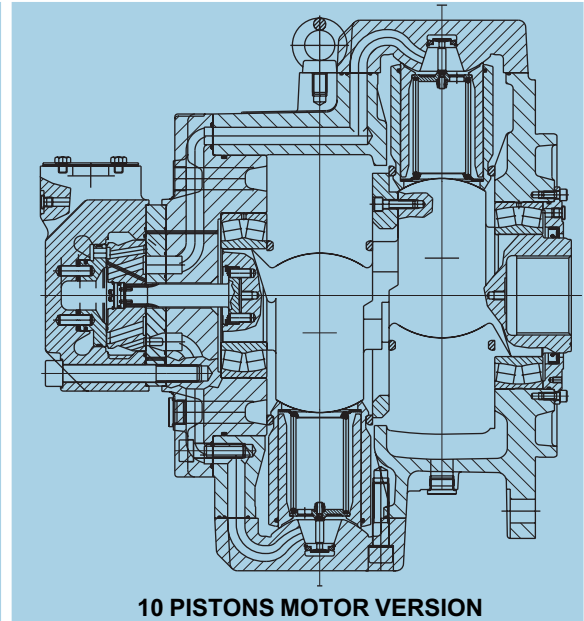
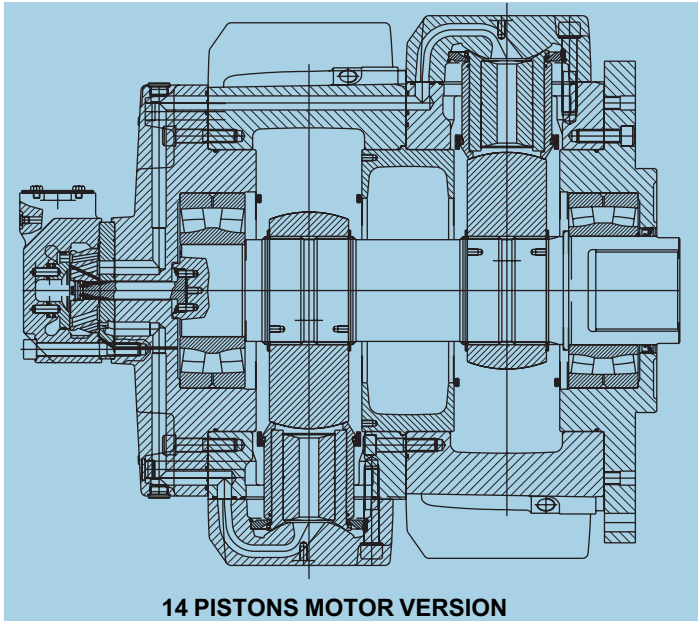

CONSTRUCTION	Fixed displacement radial piston motor
TYPE	MRT, MRTE, MRTF
MOUNTING	Front flange mounting
CONNECTION	Connection flange
MOUNTING POSITION	Any (please note the installation notes on page 22)
DIRECTION OF ROTATION	Clockwise, anti-clockwise -reversible
FLUID	HLP mineral oils to DIN 51 524 part 2; Fluid type HFB, HFC and Bio-fluids on enquiry. FPM seals are required with phosphorous acid-Ester (HFD)
FLUID TEMPERATURE RANGE	t °C – 30° a + 80°
VISCOSITY RANGE ¹⁾	ν mm ² /s 18 to 1000: Recommended operating range 30 to 50 mm ² /s (see fluid selection on page 6)
FLUID CLEANLINESS	Maximum permissible degree of contamination of fluid NAS 1638 Class 9. We therefore recommend a filter with a minimum retention rate of $\beta_{10} \geq 75$. To ensure a long life we recommend class 8 to NAS 1638. This can be achieved with a filter, with a minimum retention rate of $\beta_5 \geq 100$.

1) For different valves of viscosity please contact PARKER Calzoni

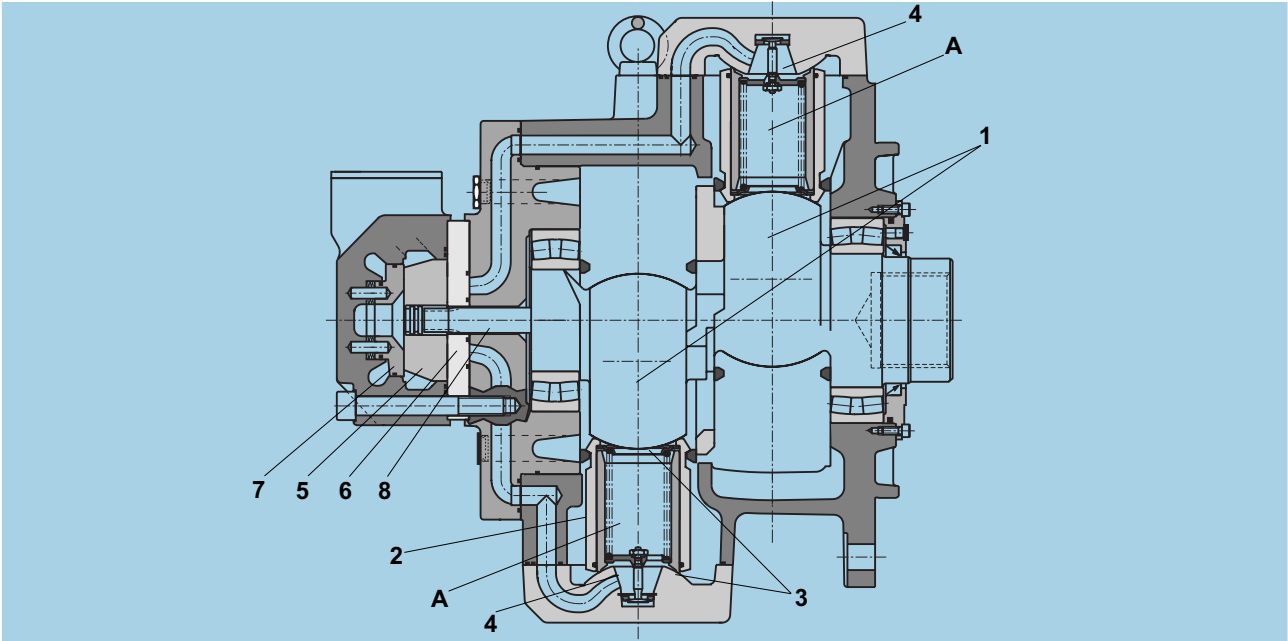

FUNCTIONAL DESCRIPTION

The outstanding performance, which is already known in our MR - MRE series motors, is the result of an original and patented design. The principle is to transmit the effort from the stator to the rotating shaft (1) by means of a pressurized column of oil (A) instead of the more common connecting rods, pistons, pads and pins. This oil column is contained by a telescopic cylinder (2) with a mechanical connection at the lips at each end which seal against the spherical surfaces (3) of the cylinder-heads (4) and the spherical surface of the rotating shaft (1). These lips retain their circular cross section when stressed by the pressure so there is no alteration in the sealing geometry. The particular selection of materials and optimisation of design has minimized both the friction and the leakage. Another advantage of this design stems from the elimination of any connecting rods, the cylinder can only expand and retract linearly so there are no transverse components of the thrust. This means no oval wear on the moving parts and no side forces on the cylinder joints. A consequence of this novel design as a 10 piston motor is the significant reduction in dimensions. Especially the diameter is limited to a value of motors with half of its capacity. Performances reached by this motor type are improved with reference to other motors of same displacement. Another advantage stems from the geometrical arrangement of the 10 - 14 pistons, that results in a static balance of the motor shaft and in a great reduction of the reaction forces on the bearings with consequent large extension of their life time.

TIMING SYSTEM

The timing system is realized by means of a rotary valve (5) driven by the rotary valve driving shaft (8) that it is connected to the rotating shaft. The rotary valve rotates between the rotary valve plate (6) and the reaction ring (7) which are fixed with the motor's housing. This timing system is also of a patented design being pressure balanced and self compensating for thermal expansion. The motor sizes from MRTE 16500 to MRTE 23000 are available with large timing system option that allows higher motor power performances as well as the possibility to have a throughhollow shaft (see pages 5, 18-19).

EFFICIENCY

The advantages of this type of valve coupled with a revolutionary cylinder arrangement produce a motor with extremely high values of mechanical and volumetric efficiency. The torque output is smooth even at very low speed and the motor gives a high performance starting under load.

TECHNICAL DATA - MOTOR TYPE MRT - MRTE - MRTF

STANDARD TIMING TECHNICAL DATA

Size Motor version	Displacement	Moment inertia of rotating parts	Theoretical specific torque	Min. start. torque % Theoretical torque	Maximum Pressure					Speed range		Maximum output power		Weight
					input					flushing		flushing		
					cont.	int.	peak	A+B *	Drain	without	with	without	with	
					p	p	p	p	p	n	n	P	P	
	V	J		%	p	p	p	p	p	n	n	P	P	m
	cm ³	kg m ²	Nm/bar		bar	bar	bar	bar	bar	rpm	rpm	kW	kW	kg
MRT 7100	7104,4	0,82	113,1	91	250	300	420	400	5 (15 bar with "F1" shaft seal)	0,5-75	0,5-150	226	330	920
MRTF 7800	7808,4	0,82	124,3	91	210	250	350	400		0,5-70	0,5-130	191	280	920
MRTE 8500	8517,3	0,82	135,6	91	210	250	350	400		0,5-60	0,5-120	198	290	920
MRT 9000	9005,5	1,32	143,4	91	250	300	420	400		0,5-70	0,5-130	253	370	920
MRTF 9900	9903,9	1,32	157,7	91	210	250	350	400		0,5-60	0,5-120	205	300	920
MRTE 10800	10802,4	1,32	172,0	91	210	250	350	400		0,5-65	0,5-110	212	310	920
MRT 14000	14010	126	223,0	91	250	300	420	400		0,5-50	0,5-80	238	355	3100
MRTF 15500	15277	126	243,1	91	210	250	350	400		0,5-40	0,5-75	204	305	3115
MRTE 16500	16543	126	263,3	91	210	250	350	400		0,5-40	0,5-70	206	308	3130
MRT 17000	16759	126	266,7	91	250	300	420	400		0,5-40	0,5-70	248	371	3100
MRTF 18000	18025	126	286,8	91	210	250	350	400		0,5-40	0,5-65	215	320	3115
MRT 19500	19508	126	310,5	91	250	300	420	400		0,5-35	0,5-60	248	371	3100
MRTE 20000	19788	126	314,9	91	210	250	350	400		0,5-35	0,5-60	212	316	3130
MRTF 21500	21271	126	338,5	91	210	250	350	400		0,5-30	0,5-55	209	311	3115
MRTE 23000	23034	126	366,6	91	210	250	350	400		0,5-30	0,5-50	205	306	3100

SPECIAL TIMING TECHNICAL DATA (please contact PARKER Calzoni)

Size Motor version	Displacement	Moment inertia of rotating parts	Theoretical specific torque	Min. start. torque % Theoretical torque	Maximum Pressure					Speed range		Maximum output power		Weight
					input					flushing		flushing		
					cont.	int.	peak	A+B *	Drain	without	with	without	with	
					p	p	p	p	p	n	n	P	P	
	V	J		%	p	p	p	p	p	n	n	P	P	m
	cm ³	kg m ²	Nm/bar		bar	bar	bar	bar	bar	rpm	rpm	kW	kW	kg
MRTE 16500	16543	126	263,3	91	210	250	350	400	5 (15 bar with "F1" shaft seal)	0,5-50	0,5-80	236	352	3130
MRT 17000	16759	126	266,7	91	250	300	420	400		0,5-50	0,5-80	284	425	3100
MRTF 18000	18025	126	286,8	91	210	250	350	400		0,5-50	0,5-80	248	370	3115
MRT 19500	19508	126	310,5	91	250	300	420	400		0,5-50	0,5-80	331	494	3100
MRTE 20000	19788	126	314,9	91	210	250	350	400		0,5-45	0,5-75	265	395	3130
MRTF 21500	21271	126	338,5	91	210	250	350	400		0,5-45	0,5-75	284	425	3115
MRTE 23000	23034	126	366,6	91	210	250	350	400		0,5-45	0,5-75	308	460	3100

(*) Please consult PARKER Calzoni

EXAMPLE: At a certain ambient temperature, the operating temperature in the circuit is 50°C. In the optimum operating viscosity range (v_{rec} : shaded section), this corresponds to viscosity grades VG 46 or VG 68; VG 68 should be selected.

IMPORTANT: The drain oil temperature is influenced by pressure and speed and is usually higher than the circuit temperature or the tank temperature. At no point in the system, however, may the temperature be higher than 80°C.

If the optimum conditions cannot be met due to the extreme operating parameters or high ambient temperature, we always recommend flushing the motor case in order to operate within the viscosity limits.

Should it be absolutely necessary to use a viscosity beyond the recommended range, you should first contact PARKER Calzoni for confirmation.

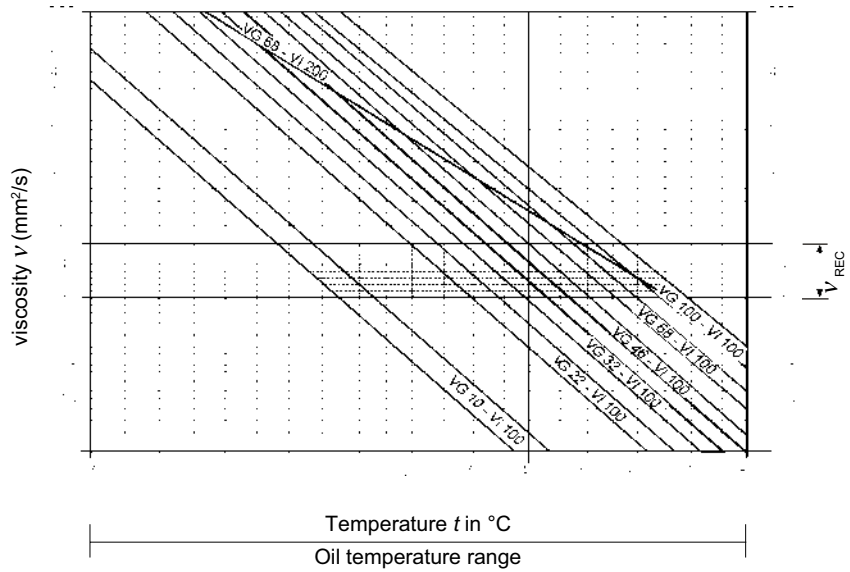

GENERAL NOTES

More detailed information regarding the choice of the fluid can be requested to PARKER Calzoni. Further notes on installation and commissioning can be found on page 34 of this data sheet. When operating with HF pressure fluids or bio-degradable pressure fluids possible limitations of the technical data must be taken into consideration, please see information sheet TCS 85, or consult PARKER Calzoni.

OPERATING VISCOSITY RANGE

The viscosity, quality and cleanliness of operating fluids are decisive factors in determining the reliability, performance and life-time of an hydraulic component. The maximum life-time and performance are achieved within the recommended viscosity range. For applications that go beyond this range, we recommend to contact PARKER Calzoni.

$$v_{rec} = \text{recommended operating viscosity } 30...50 \text{ mm}^2/\text{s}$$

This viscosity refers to the temperature of the fluid entering the motor, and at the same time to the temperature inside the motor housing (case temperature). We recommend to select the viscosity of the fluid based on the maximum operating temperature, to remain within the recommended viscosity range. To reach the value of maximum continuous power the operating viscosity should be within the recommended viscosity range of 30 - 50 cSt.

LIMITS OF VISCOSITY RANGE

For limit conditions the following is valid:

$$v_{min.abs.} = 10 \text{ mm}^2/\text{s} \text{ in emergency, short term}$$

$$v_{min.} = 18 \text{ mm}^2/\text{s} \text{ for continuous operation at reduced performances}$$

$$v_{max.} = 1000 \text{ mm}^2/\text{s} \text{ short term upon cold start}$$

CHOOSING THE TYPE OF FLUID ACCORDING TO THE OPERATING TEMPERATURE

The operating temperature of the motor is defined as the greater temperature between that of the incoming fluid and that of the fluid inside the motor housing (case temperature). We recommend that you choose the viscosity of the fluid based on the maximum operating temperature, to remain within the recommended viscosity range (see diagram). We recommend that the higher viscosity grade must be selected in each case.

FILTRATION

The motor life also depends on the fluid filtration. At least it must correspond to one of the following cleanliness.

- class 9 according to NAS 1638
- class 6 according to SAE, ASTM, AIA
- class 18/15 according to ISO/DIS 4406

In order to assure a longer life a cleanliness class 8 to NAS 1638 is recommended, achieved with a filter of $\beta_3=100$. In case the above mentioned classes can not be achieved, please consult us.

CASE DRAIN PRESSURE

The lower the speed and the case drain pressure, the longer the life of the shaft seal. The maximum permissible housing pressure is

$$p_{max} = 5 \text{ bar}$$

If the case drain pressure is higher than 5 bar it is possible to use a special 15 bar shaft seal (see page 23, Seals, Code "F1").

"FPM" SEALS

In case of operating conditions with high oil temperature or high ambient temperature, we recommend to use "FPM" seals (see page 23, Seals, Code "V1"). These "FPM" seals should be used with HFD fluids.

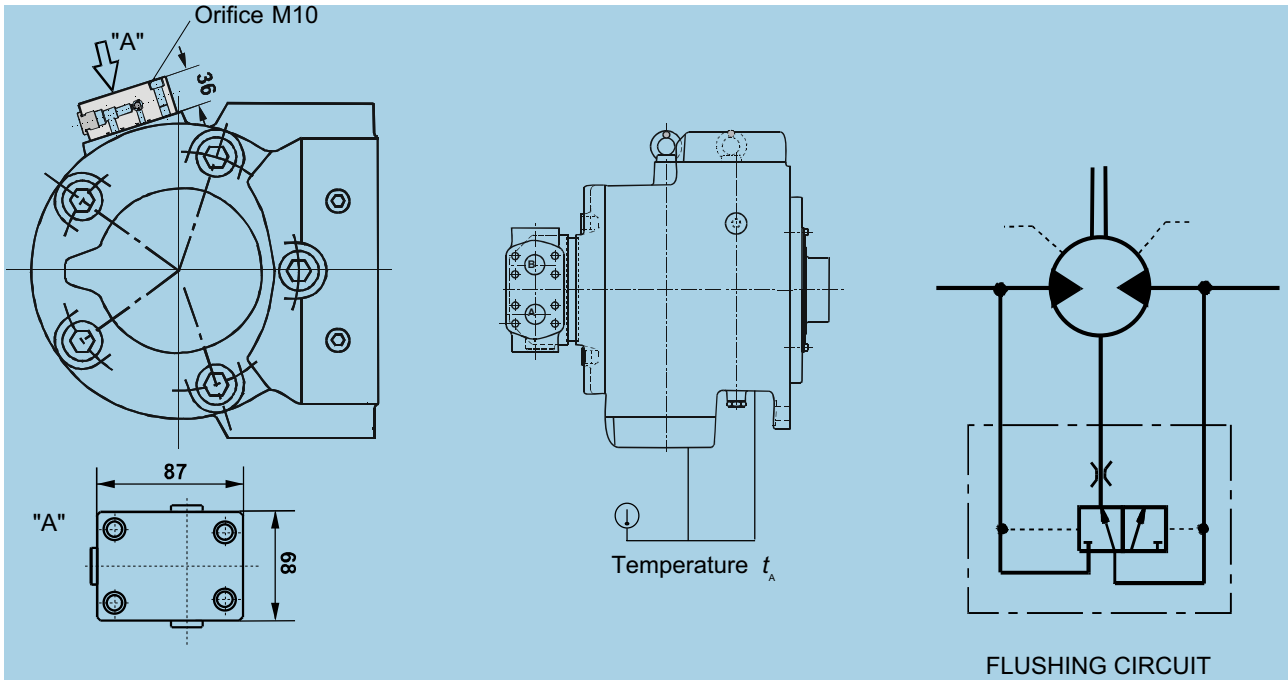

FLUSHING PROCEDURE

In order to achieve the maximum continuous performance values the flushing of the housing is necessary (see diagrams pages 8 to 12).

Under special conditions, in order to achieve the recommended operating viscosity of 30 - 50 mm²/s in the motor housing, the flushing of the motor may be necessary also in the "operating area without flushing" see page 6 and the "operating diagram" page 7 to 12.

NOTE1:

The oil temperature inside the motor housing is obtainable by adding 3° C to the motor housing surface temperature, measured between two cylinders (t_A , see figures).

FUNCTION:

The flushing valve takes the flushing flow always from the low pressure line of the motor. The diameter of the orifice has to be chosen in order to supply the recommended quantity of flushing flow of 23 l/min.

BACK PRESSURE (bar)	ORIFICE DIAMETER (mm)
3	4,8
6	4,0
9	3,6
15	3,2
20	3,0
25	2,9
30	2,8

NOTE2:

The flushing valve is delivered with a "closed" orifice.

Caution:

Flushing does not work until the "closed" orifice is replaced by the proper one.

OPERATING DIAGRAM - MOTOR TYPE MRT - MRTE - MRTF

OPERATING DIAGRAM

(average values) measured at $V = 36 \text{ mm}^2/\text{s}$; $t = 45^\circ \text{ C}$; $p_{\text{outlet}} = 0 \text{ bar}$

- 1 Output power
- 2 Intermittent operating area
- 3 Continuous operating area with flushing
- 4 Continuous operating area
- 5 Inlet pressure
- η_t Total efficiency
- η_v Volumeter efficiency

MRT 7100

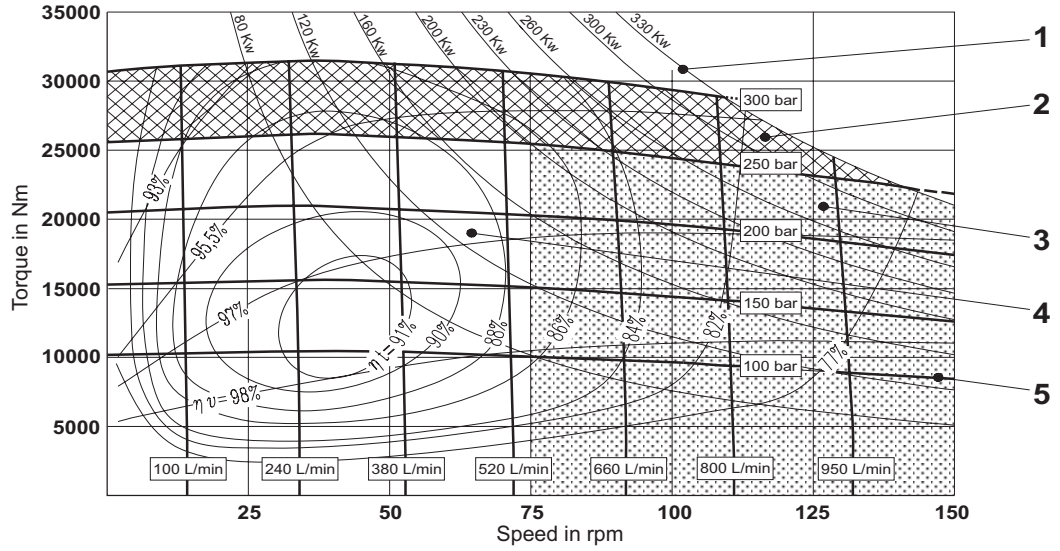

MRTF 7800

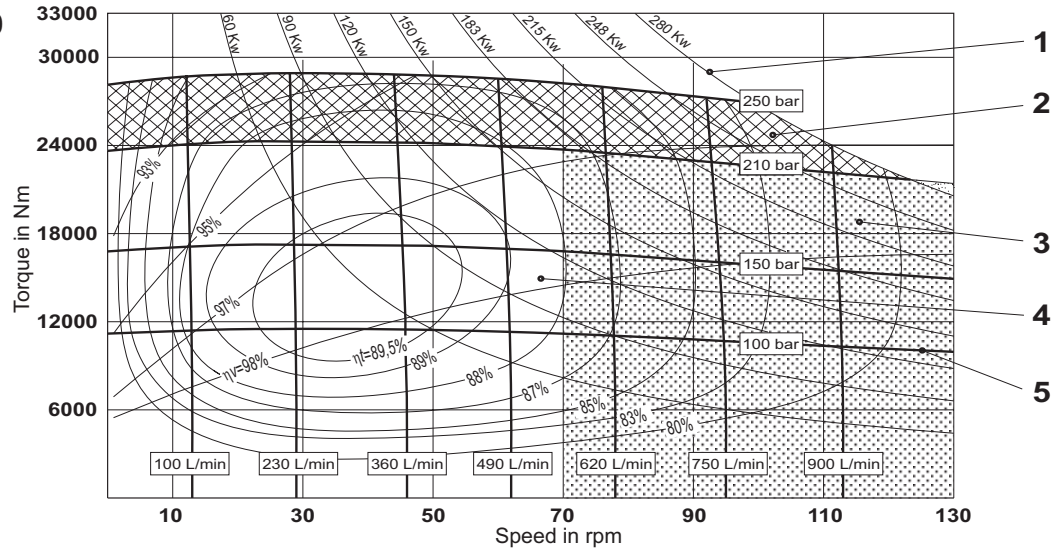

MRTE 8500

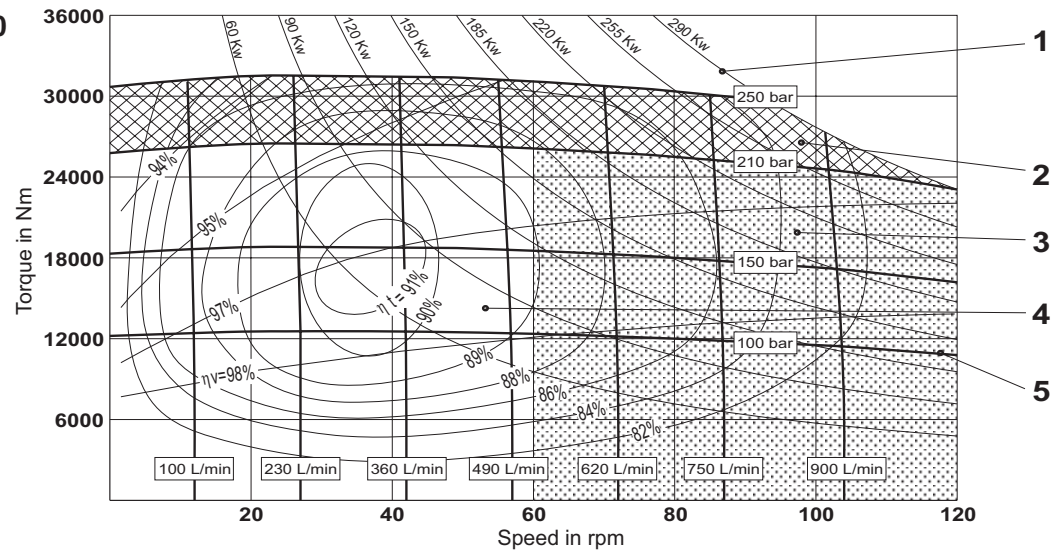

OPERATING DIAGRAM - MOTOR TYPE MRT - MRTE - MRTF

OPERATING DIAGRAM

(average values) measured at $V = 36 \text{ mm}^2/\text{s}$; $t = 45^\circ \text{ C}$; $p_{\text{outlet}} = 0 \text{ bar}$

- 1 Output power
- 2 Intermittent operating area
- 3 Continuous operating area with flushing
- 4 Continuous operating area
- 5 Inlet pressure
- η_t Total efficiency
- η_v Volumeter efficiency

MRT 9000

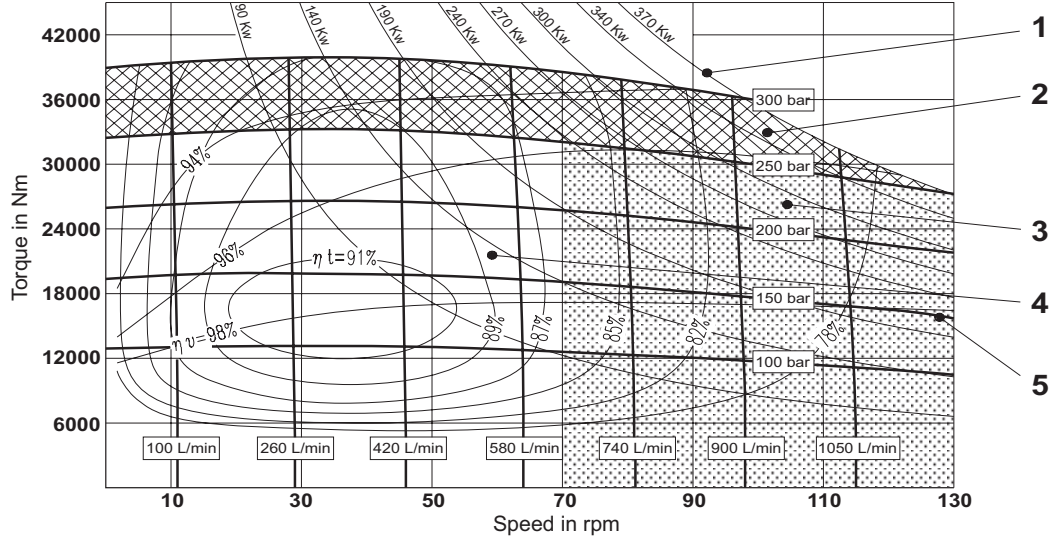

MRTF 9900

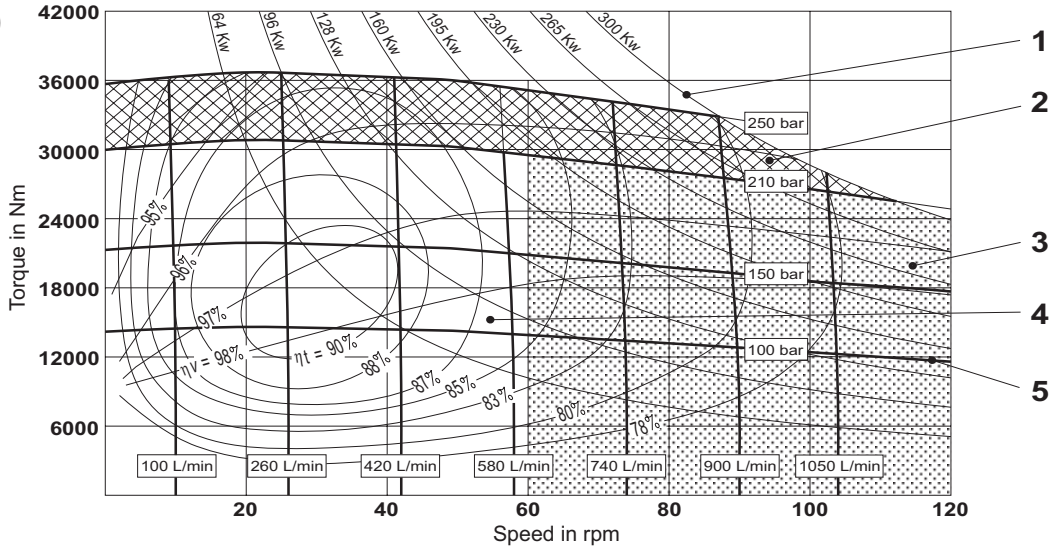

MRTE 10800

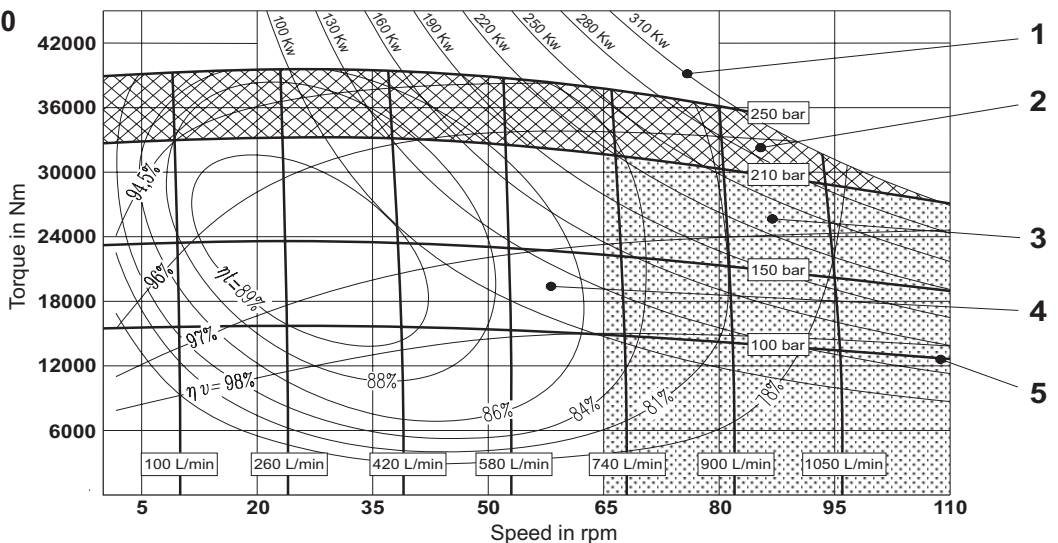

OPERATING DIAGRAM - MOTOR TYPE MRT - MRTE - MRTF

OPERATING DIAGRAM

(average values) measured at $V = 36 \text{ mm}^2/\text{s}$; $t = 45^\circ \text{ C}$; $p_{\text{outlet}} = 0 \text{ bar}$

- 1 Output power
- 2 Intermittent operating area
- 3 Continuous operating area with flushing
- 4 Continuous operating area
- 5 Inlet pressure
- η_t Total efficiency
- η_v Volumeter efficiency

MRT 14000

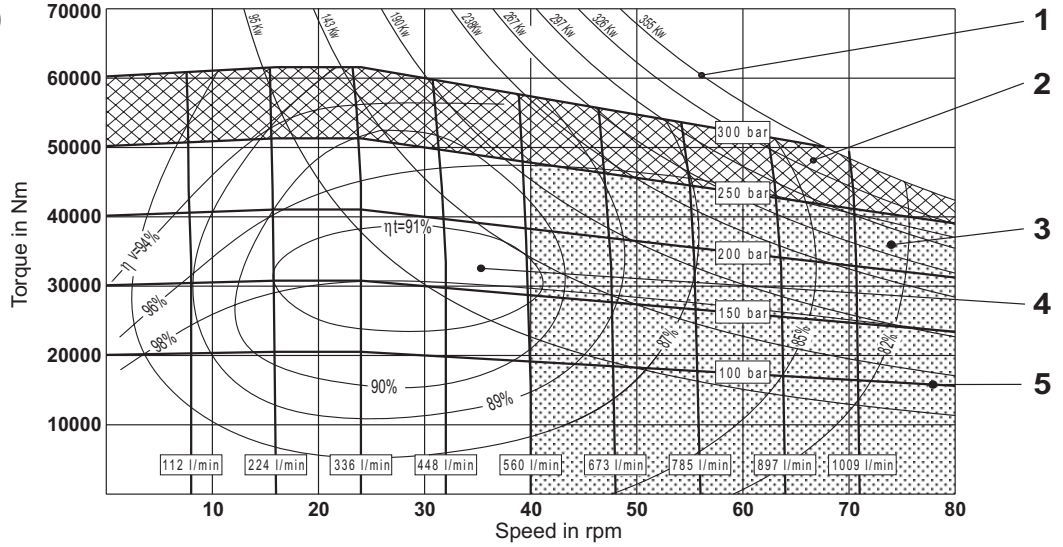

MRTF 15500

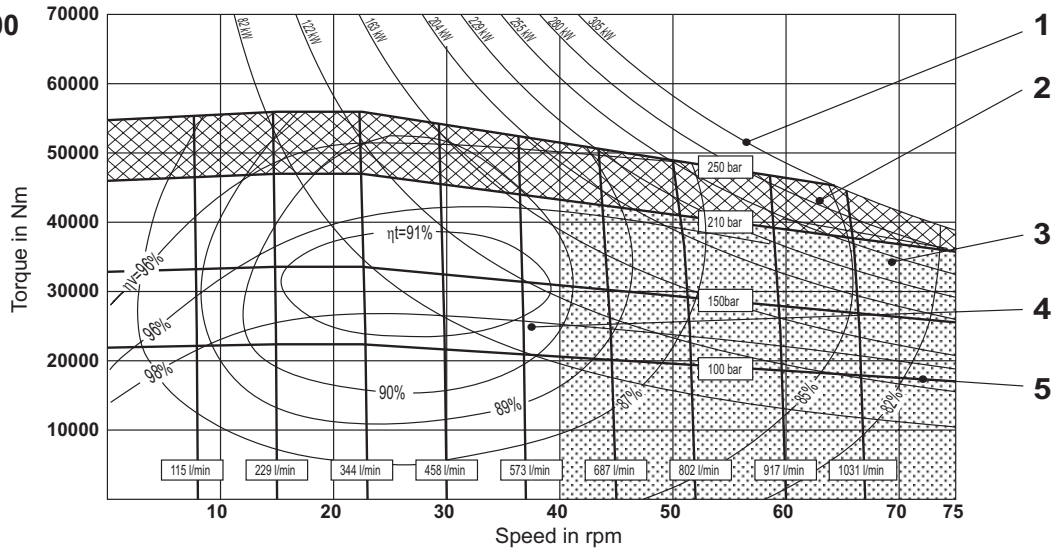

MRTE 16500

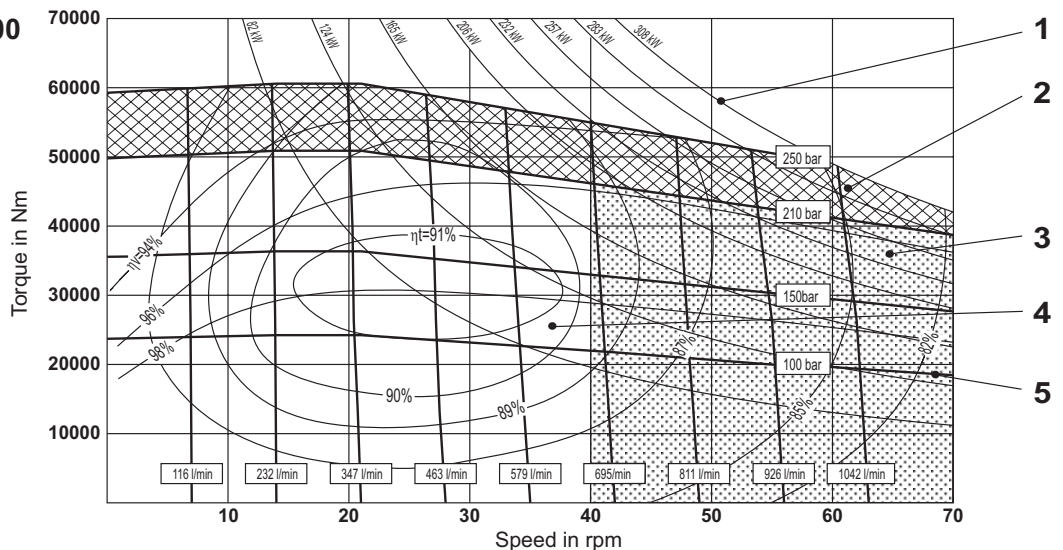

OPERATING DIAGRAM - MOTOR TYPE MRT - MRTE - MRTF

OPERATING DIAGRAM

(average values) measured at $V = 36 \text{ mm}^2/\text{s}$; $t = 45^\circ \text{ C}$; $p_{\text{outlet}} = 0 \text{ bar}$

- 1 Output power
- 2 Intermittent operating area
- 3 Continuous operating area with flushing
- 4 Continuous operating area
- 5 Inlet pressure
- η_t Total efficiency
- η_v Volumetric efficiency

MRT 17000

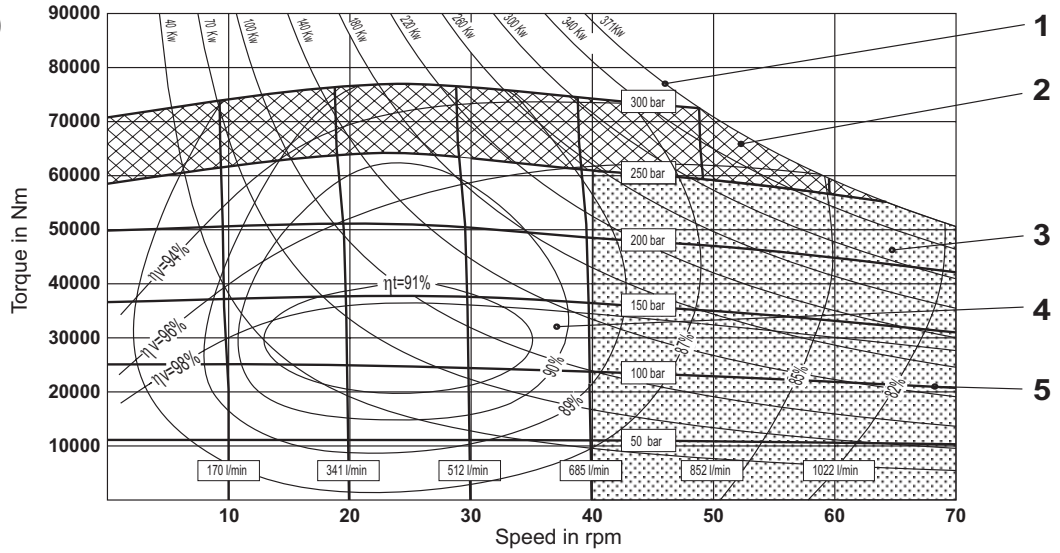

MRTF 18000

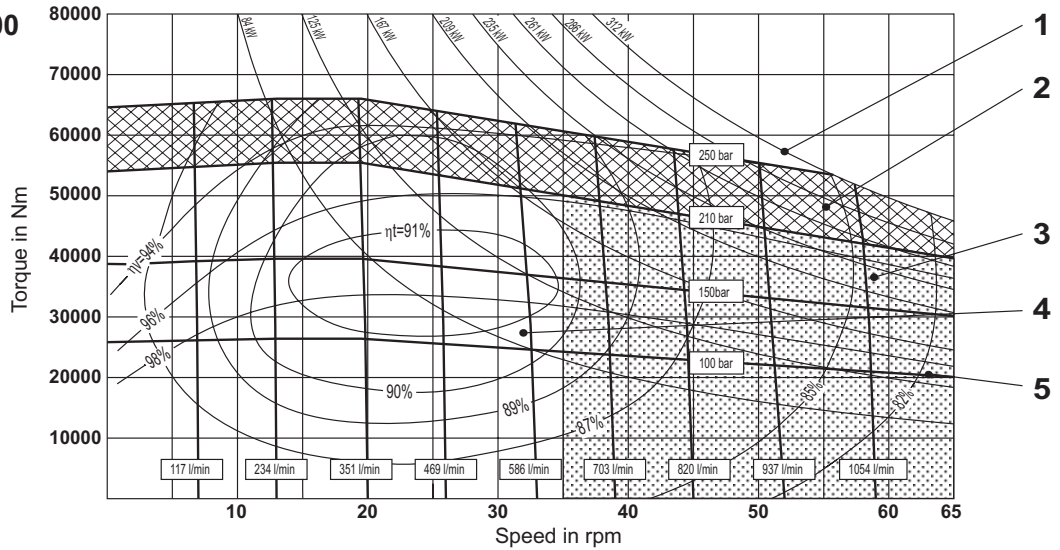

MRT 19500

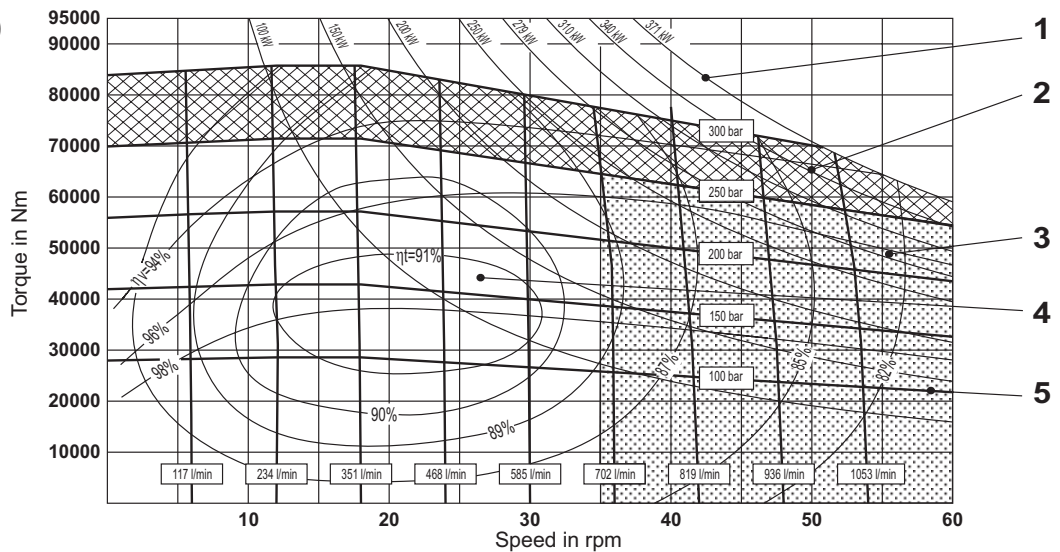

OPERATING DIAGRAM - MOTOR TYPE MRT - MRTE - MRTF

OPERATING DIAGRAM

(average values) measured at $V = 36 \text{ mm}^2/\text{s}$; $t = 45^\circ \text{ C}$; $p_{\text{outlet}} = 0 \text{ bar}$

- 1 Output power
- 2 Intermittent operating area
- 3 Continuous operating area with flushing
- 4 Continuous operating area
- 5 Inlet pressure
- η_t Total efficiency
- η_v Volumeter efficiency

MRTE 20000

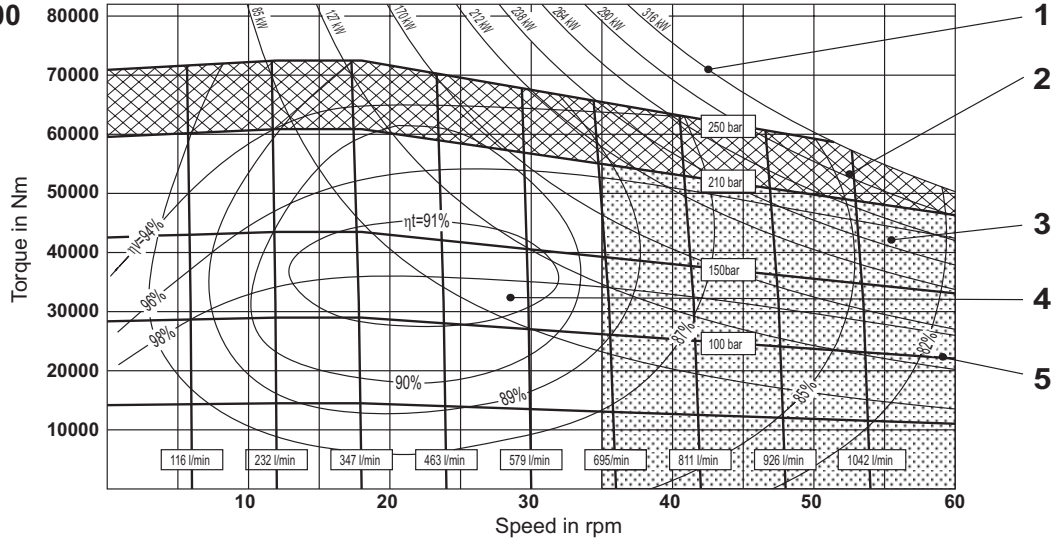

MRTF 21500

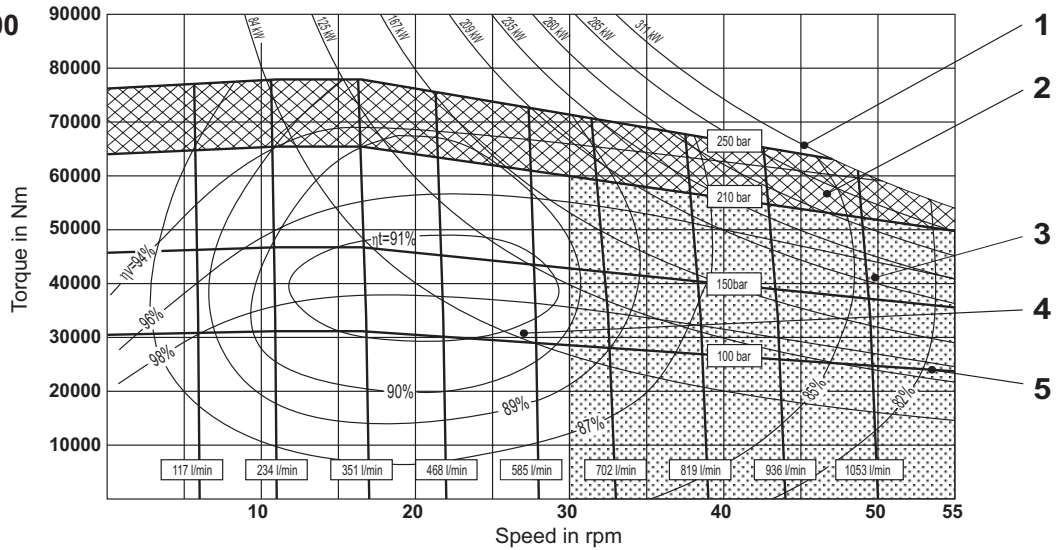

MRTE 23000

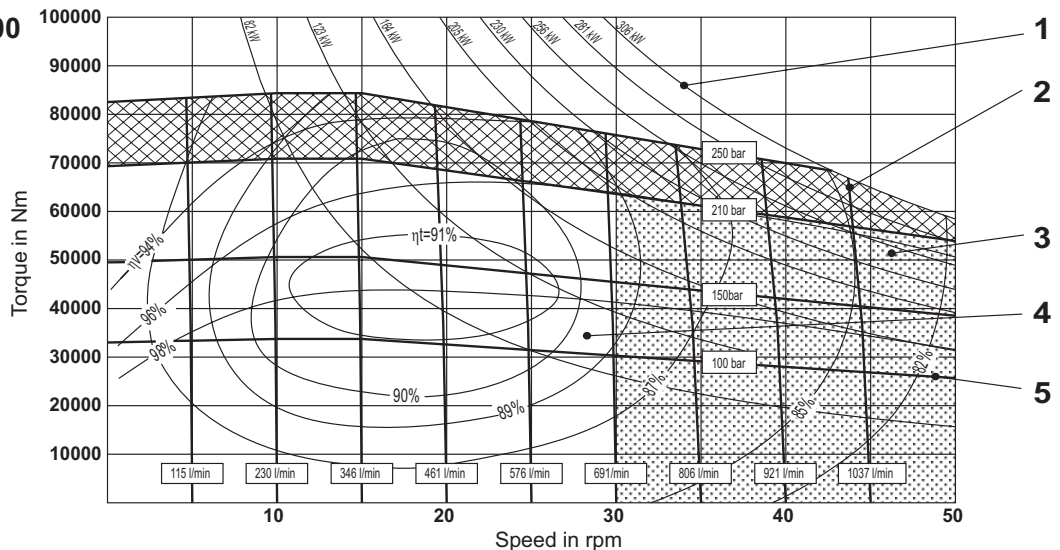

OPERATING DIAGRAM - MOTOR TYPE MRT - MRTE - MRTF

OPERATING DIAGRAM (average values) measured at $V = 36 \text{ mm}^2/\text{s}$; $t = 45^\circ \text{ C}$; $p_{\text{outlet}} = 0 \text{ bar}$

Min. required pressure difference Δp with idling speed (shaft unloaded)

**MRT - MRTE - MRTF
7100 - 8500**

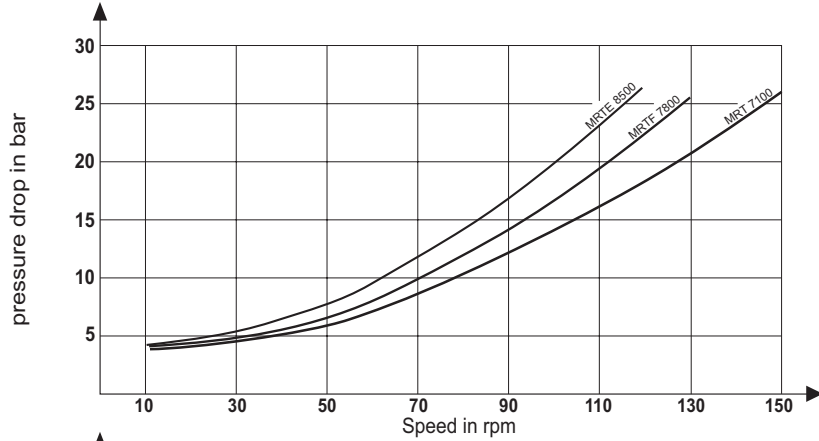

**MRT - MRTE - MRTF
9000 - 10800**

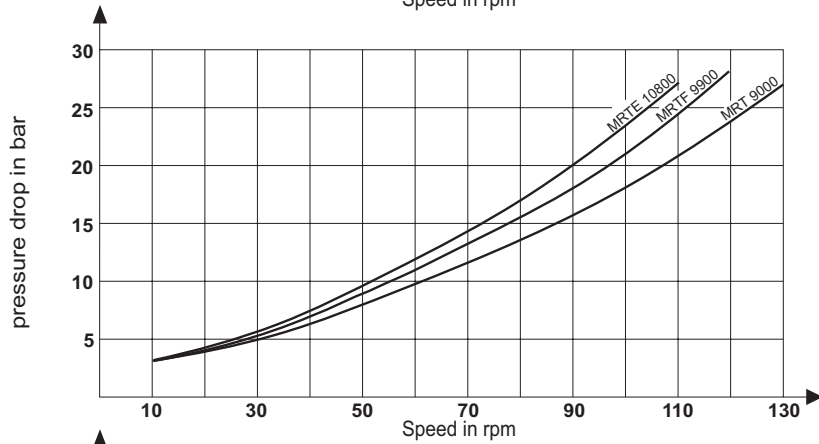

**MRT - MRTE - MRTF
14000 - 16500**

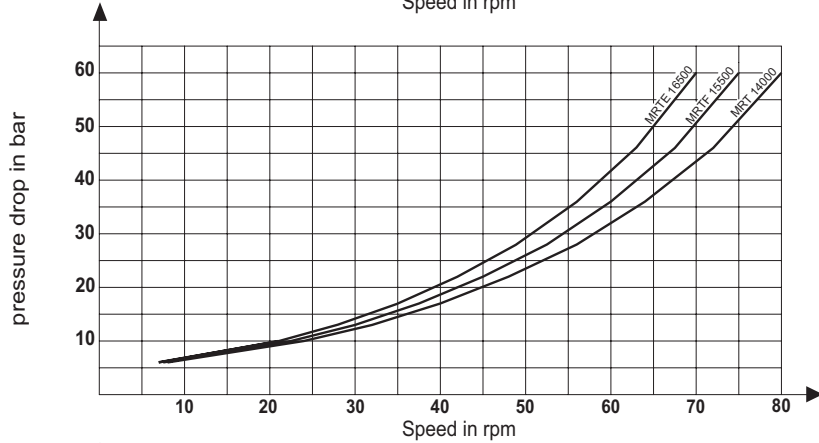

**MRT - MRTE - MRTF
17000 - 20000**

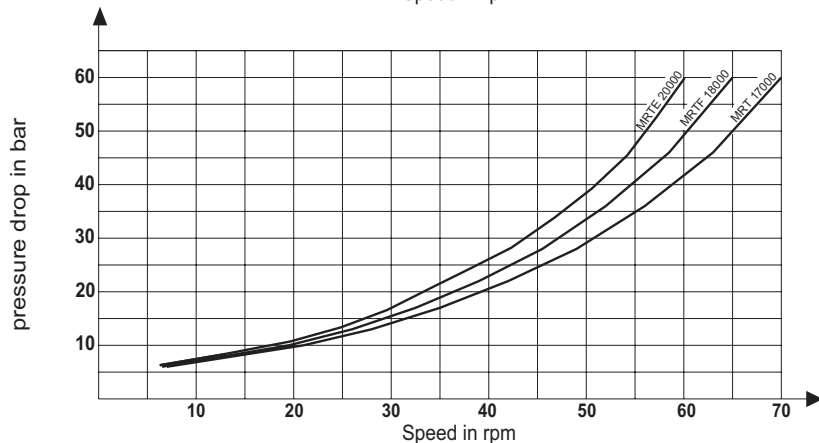

OPERATING DIAGRAM - MOTOR TYPE MRT - MRTE - MRTF

OPERATING DIAGRAM (average values) measured at $V = 36 \text{ mm}^2/\text{s}$; $t = 45^\circ \text{ C}$; $p_{\text{outlet}} = 0 \text{ bar}$
Min. required pressure difference Δp with idling speed (shaft unloaded)

MRT - MRTE - MRTF
19500 - 23000

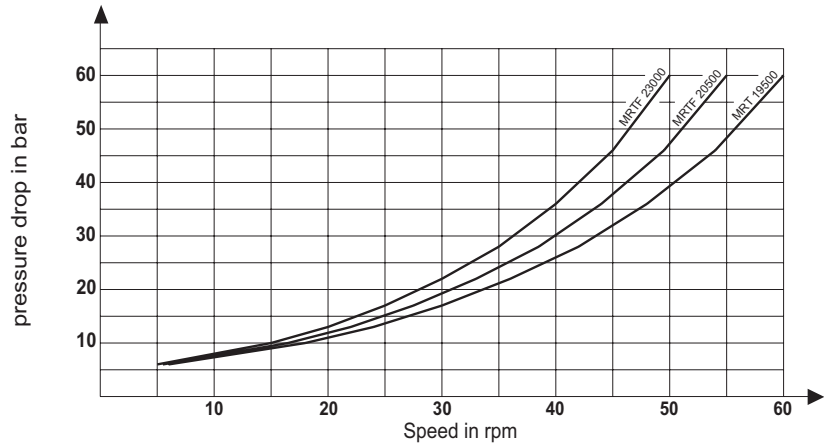

Minimum boost pressure during pump operation

MRT - MRTE - MRTF
7100 - 8500

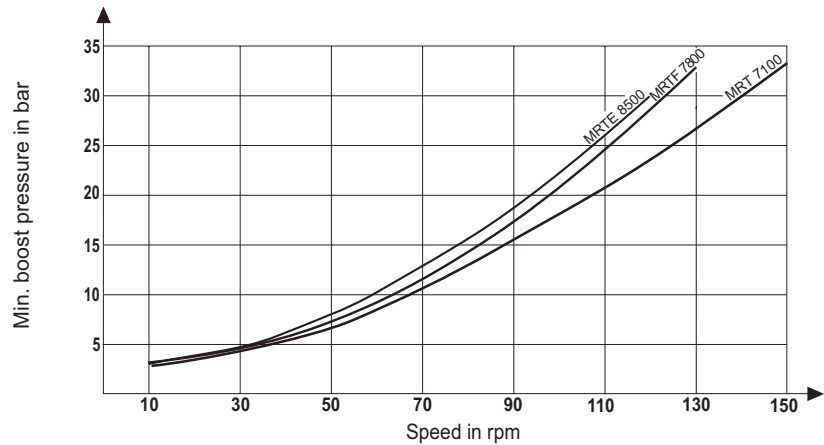

MRT - MRTE - MRTF
9000 - 10800

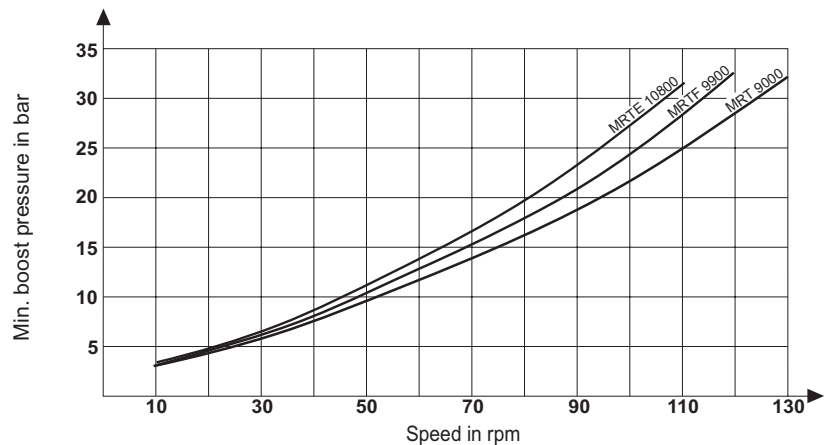

OPERATING DIAGRAM (average values) measured at $V = 36 \text{ mm}^2/\text{s}$; $t = 45^\circ \text{ C}$; $p_{\text{outlet}} = 0 \text{ bar}$

Minimum boost pressure during pump operation

**MRT - MRTE - MRTF
14000 - 16500**

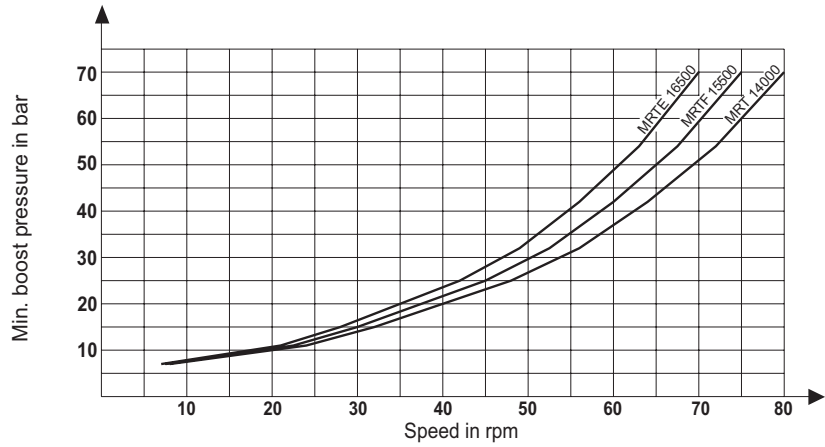

**MRT - MRTE - MRTF
17000 - 20000**

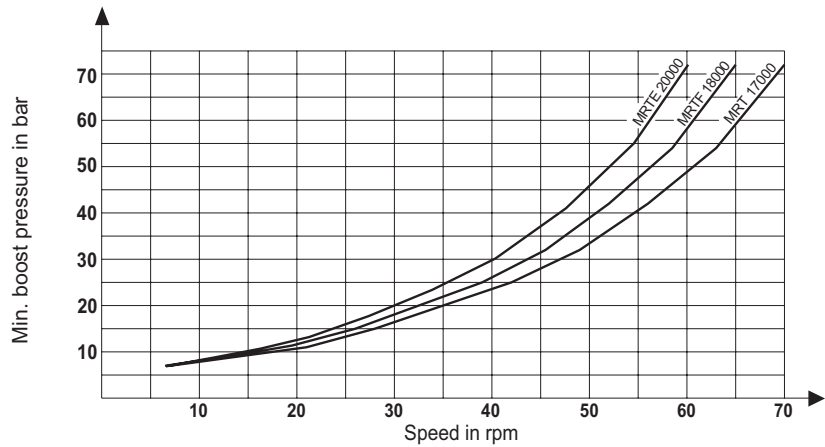

**MRT - MRTE - MRTF
19500 - 23000**

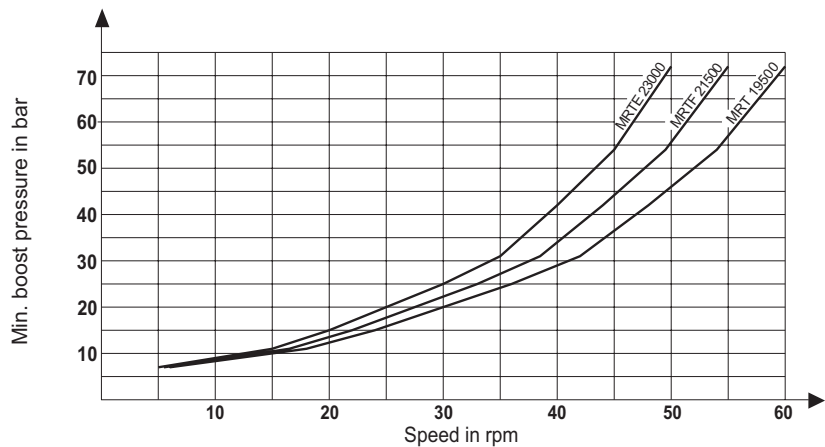

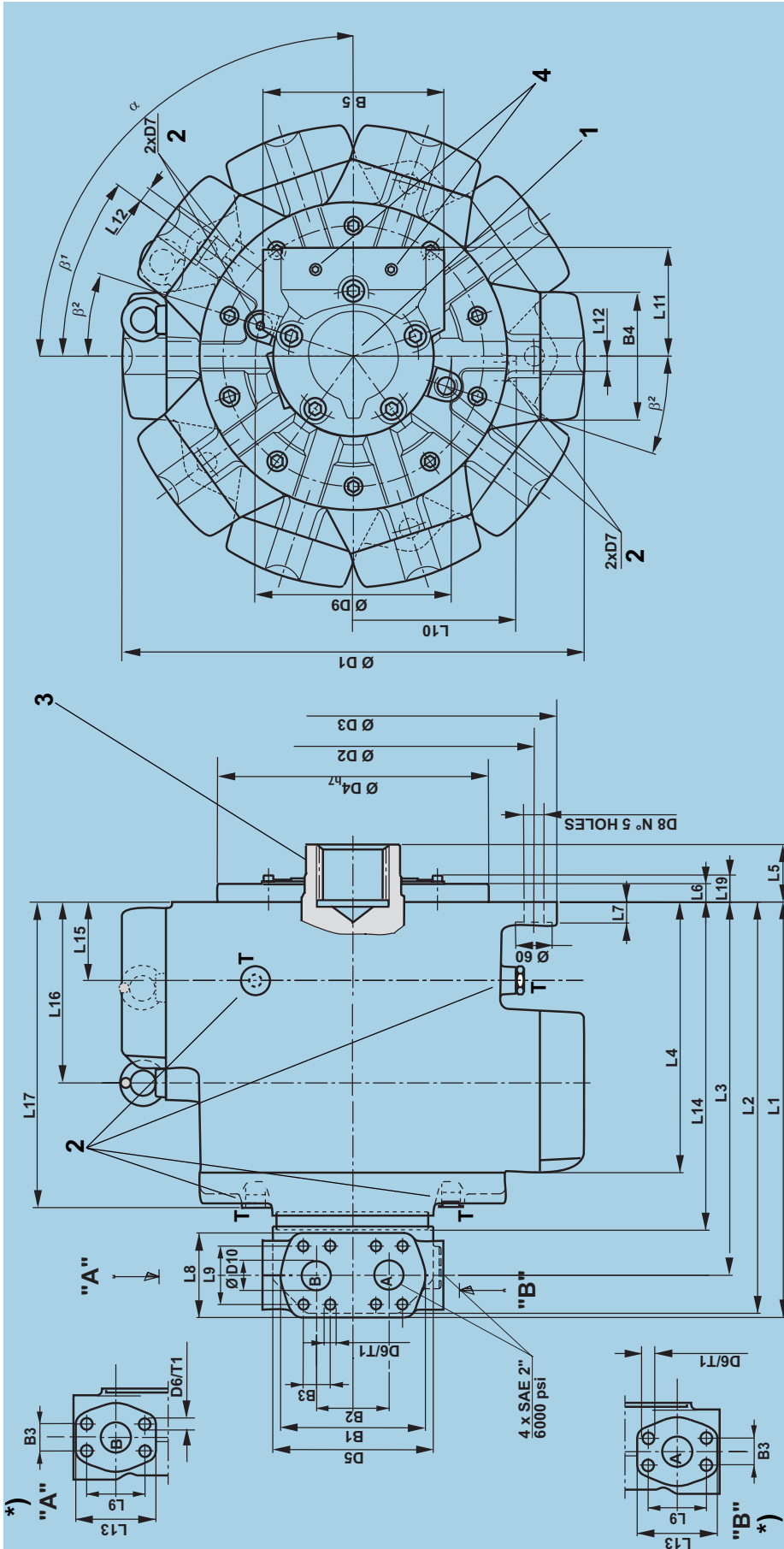

Dir. of Rotation (Viewed on shaft end)	Port inlet	ordering code (see page23)
clockwise	A	"N"
anti-clockwise	B	"S"
clockwise	B	"S"
anti-clockwise	A	"S"

- 2 Case drain port
BSP threads to ISO 228/1
- 3 See dimensions at page 17
- 4 Port 1/4" BSP threads to ISO 228/1
for pressure reading.

- 1 On request port flange can be rotated by 72°
- *) These SAE ports are present only in the
MRT 9000P, MRTF 9900P, MRTE 10800P,
MRT 14000Q, MTRF15500Q, MRTE16500,
MRT 17000Q, MRTF 18000Q, MRT 19500Q,
MRTE 20000Q, MRTF 21500Q e MRTE 23000Q

MOTOR DIMENSIONS - MOTOR TYPE MRT - MRTE - MRTF

MOTOR TYPE	L1	L2	L3	L4	L6	L7	L8	L9		L10	L11	L12	L13	L14	L15	L16	L17	L19	B1	B2	B3		B4	B5
								SAE 3000 psi	SAE 6000 psi												SAE 3000 psi	SAE 6000 psi		
MRT 7100 MRTF 7800 MRTE 8500 MRT 9000 MRTF 9900 MRTE 10800	688,5	681,5	618,5	448,5	30	35	140	77,77	96,8	270	180	25	133	541,5	130	300	503,5	44	240	120	42,88	44,4	212	300

MOTOR TYPE	∅ D1	∅ D2	∅ D3	∅ D4 _{tr}	∅ D5	D6		T1		D7	∅ D8	∅ D9	∅ D10	α	β ¹	β ²
						SAE 3000 psi	SAE 6000 psi	SAE 3000 psi	SAE 6000 psi							
MRT 7100 MRTF 7800 MRTE 8500 MRT 9000 MRTF 9900 MRTE 10800	766	600	676	450	266	M12	M20	28	40	G1"	33 (x5)	325	50	90°	36°	18°

Code F 1 - DIN 5480

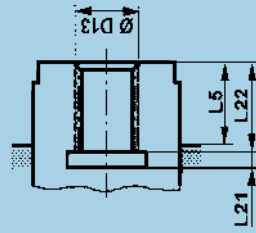

Code D 1 - DIN 5480

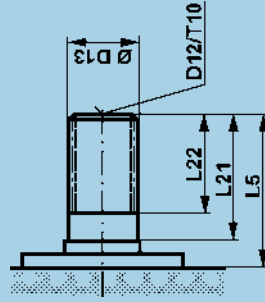

MOTOR TYPE	F1				D1			
	L5	L21	L22	∅ D13 DIN 5480	L5	L21	L22	∅ D13 DIN 5480
MRT 7100 MRTF 7800 MRTE 8500	50	14	76	N 110x3x35 - 9H	--	--	--	--
MRT 9000 MRTF 9900 MRTE 10800	95	14	86	N 120x4x28 - 9H	250	205	167	W 140x5x26 - 8f M12

NOTE: the threaded holes (D12/T10) for the shaft versions "D1" must be considered as service holes. In case the holes dimensions required by the application are different from the ones listed here above, please contact PARKER Calzoni.

MOTOR DIMENSIONS - MOTOR TYPE MRT - MRTE - MRTF

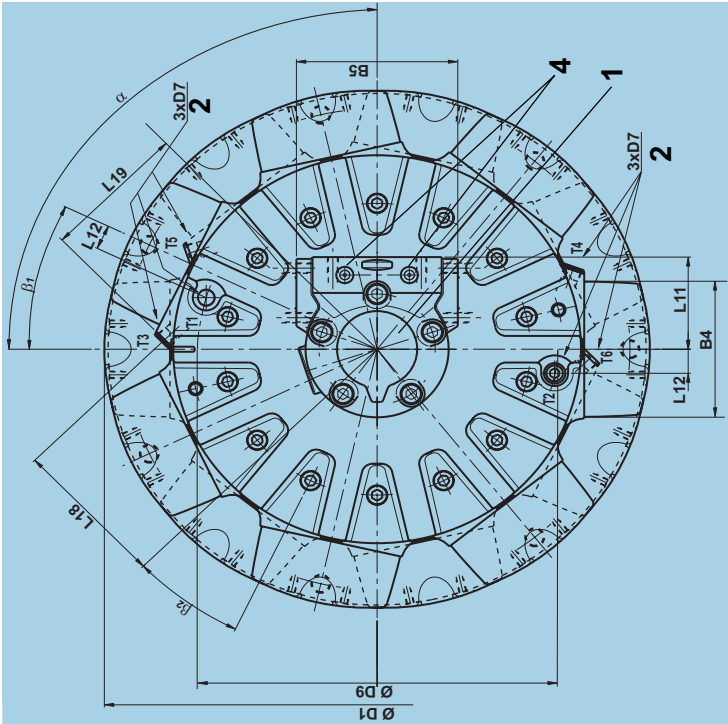

1 On request port flange can be rotated by 72°

*) These SAE ports are present only in the
MRT 14000Q, MTRF15500Q, MRTE16500, MRT 17000Q,
MRTF 18000Q, MRT 19500Q, MRTE 20000Q, MRTF 21500Q e
MRTE 23000Q

2 Case drain port BSP threads to ISO 228/1

3 See dimensions at page 19

4 Port 1/4" BSP threads to ISO 228/1 for pressure reading.

Dir. of Rotation (Viewed on shaft end)	Port inlet	ordering code (see page23)
clockwise	A	"N"
anti-clockwise	B	"S"
clockwise	B	"S"
anti-clockwise	A	"S"

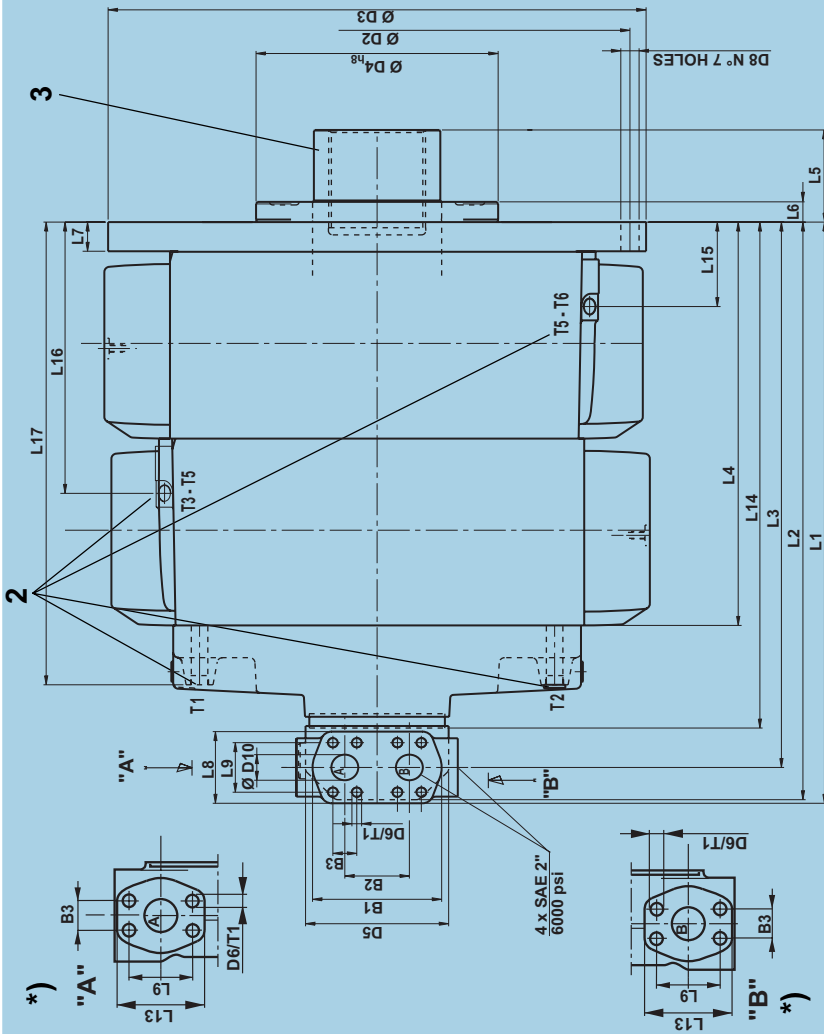

SPECIAL TIMING

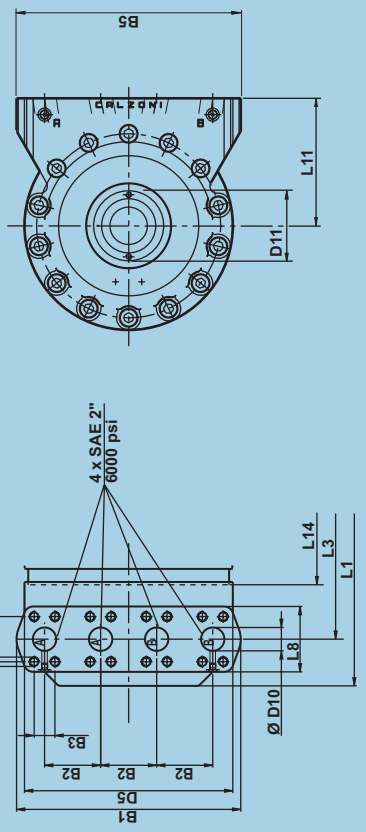

*) "A" B3 L9 L13 D6/T1 Ø D10 L8

*) "B" L9 L13 D6/T1 B3

MOTOR DIMENSIONS - MOTOR TYPE MRT - MRTE - MRTF

MOTOR TYPE	L1	L2	L3	L4	L5	L6	L7	L8	L9		L11	L12	L13	L14	L15	L16	L17	L18	L19	B1	B2	B3		B4	B5	α	β_1	β_2	
									SAE 3000 psi	SAE 6000 psi														SAE 3000 psi	SAE 6000 psi				
MRT 14000																													
MRTF 15500																													
MRTE 16500																													
MRT 17000																													
MRTF 18000	1135,5	1128,5	1065,5	788	80	39,5	58	140	77,77	96,8	180	47	133	988,5	165	530	904	289	270	240	120		42,88	44,4	270	300	90°	25°41'	20°
MRT 19500																													
MRTE 20000																													
MRTF 21500																													
MRTE 23000																													

MOTOR TYPE	\emptyset D1	\emptyset D2	\emptyset D3	\emptyset D4 ₁₇	\emptyset D5	D6		T1		D7	\emptyset D8	\emptyset D9	\emptyset D10	Code F 1 - DIN 5480			
						SAE 3000 psi	SAE 6000 psi	SAE 3000 psi	SAE 6000 psi					L5	L21	L22	\emptyset D13 DIN 5480
MRT 14000																	
MRTF 15500																	
MRTE 16500																	
MRT 17000																	
MRTF 18000	1014	856	930,5	450	266	M12	M20	28	40	G1"	34 (x7)	666,6	50	80	14	155	N 150x4x36 - 9H
MRT 19500																	
MRTE 20000																	
MRTF 21500																	
MRTE 23000																	

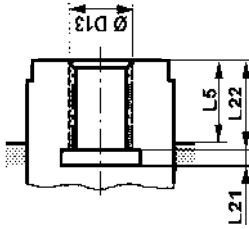

SPECIAL TIMING DIMENSIONS (please contact DENISON Calzoni)

Tipo e MOTOR TYPE	L1	L3	L5	L8	L9		L11	B1	B2	B3		B5	D6		T1		D7	\emptyset D9	\emptyset D10	\emptyset D11	Code F 1 - DIN 5480				
					SAE 3000 psi	SAE 6000 psi				SAE 3000 psi	SAE 6000 psi	SAE 3000 psi	SAE 6000 psi	SAE 3000 psi	SAE 6000 psi	SAE 3000 psi	SAE 6000 psi				L5	L21	L22	\emptyset D13 DIN 5480	
MRTE 16500																									
MRT 17000																									
MRTF 18000																									
MRT 19500	1177	1077	82	140	77,77	968	273	960,5	480	120	446	446	44,4	M12	M20	28	40	G1"	666,6	50	80	82	14	155	N 150x4x36 - 9H
MRTE 20000																									
MRTF 21500																									
MRTE 23000																									

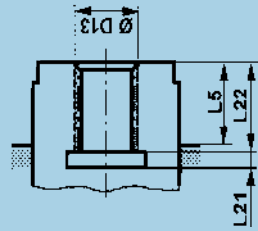

MECHANICAL
TACHOMETER DRIVE

TACHOGENERATOR
DRIVE

ENCODER
DRIVE

Code "C1"

Code "T1"

Code "Q1"

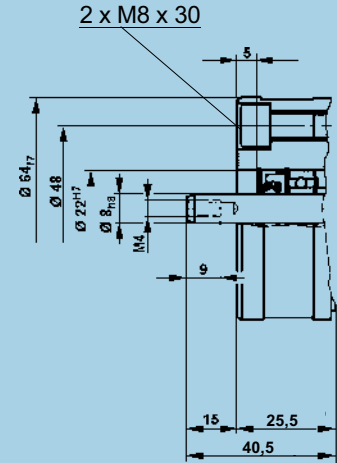
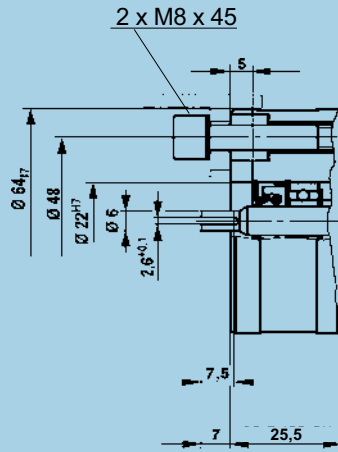
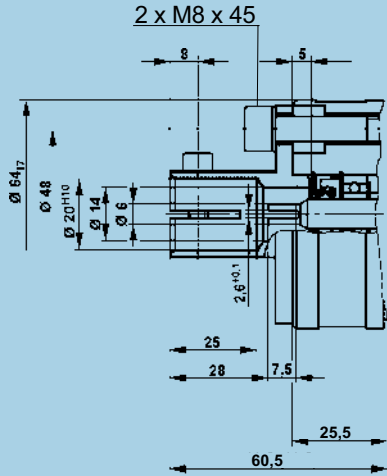

Timing standard

INCREMENTAL ENCODER
DIMENSIONS

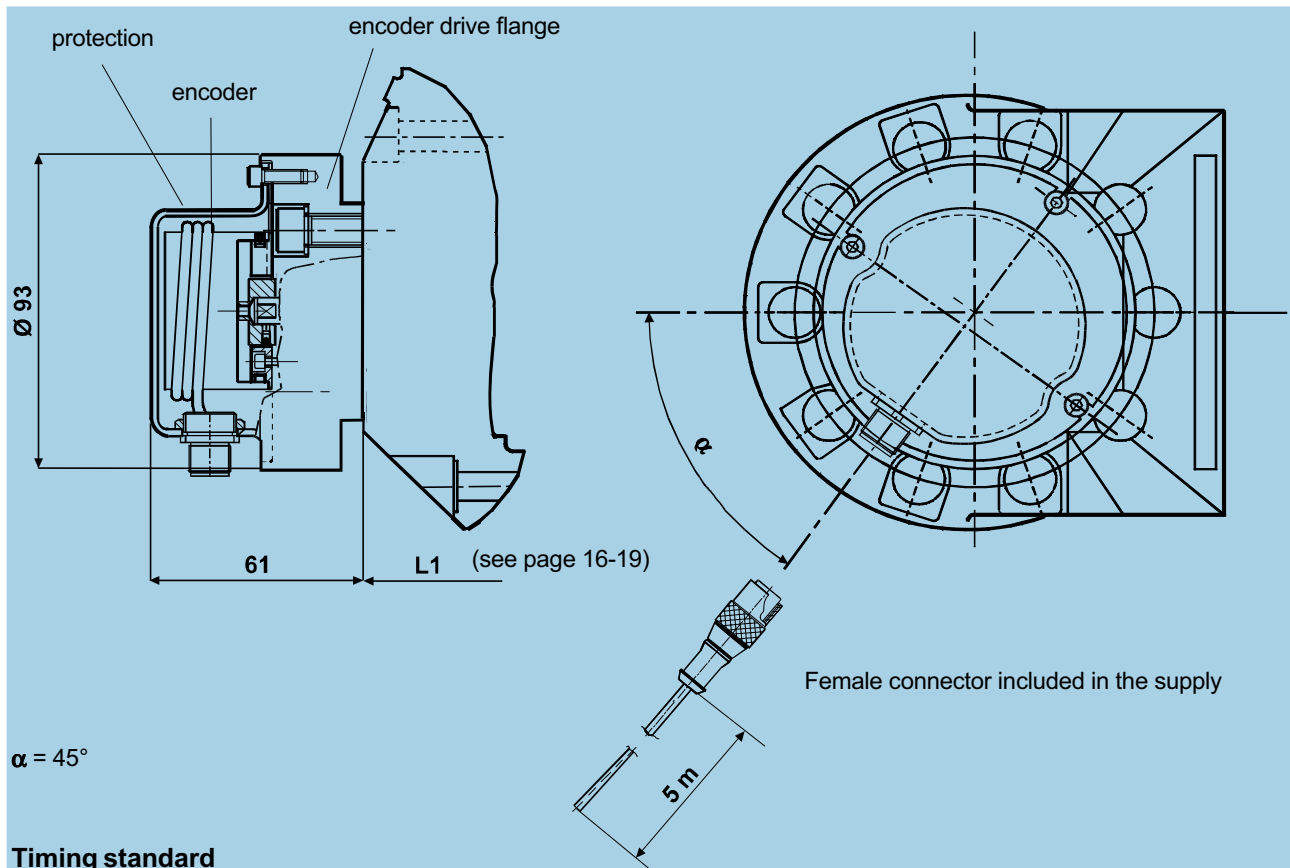

Timing standard

INCREMENTAL ENCODER
CONNECTION DIAGRAMS

Monodirectional

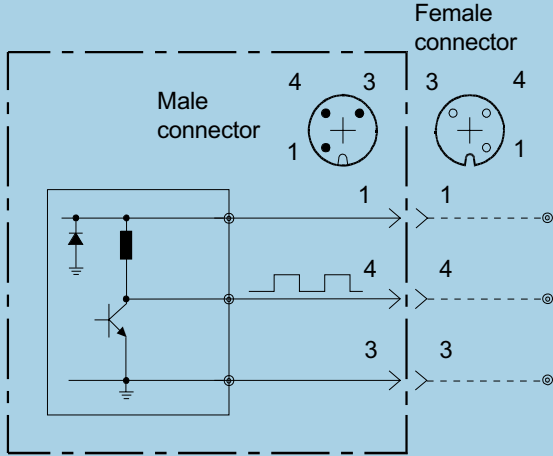

Bidirectional

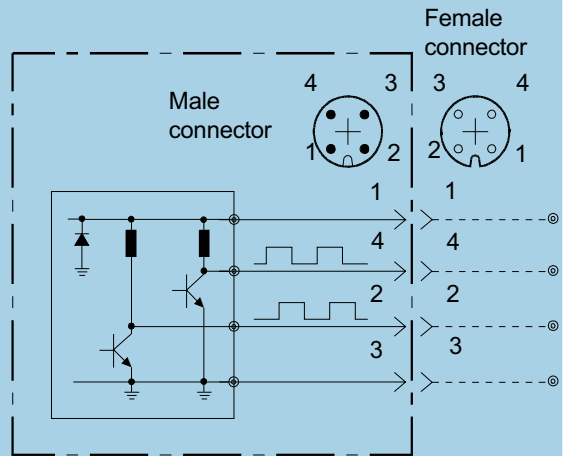

Color wires and function

Color wires and function		
1	Brown	Power Supply (8 to 24 Vdc)
2	White	Output B phase (MAX 10 mA - 24 Vcc)
3	Blue	Power Supply (0 Vdc)
4	Black	Output A phase (MAX 10 mA - 24 Vcc)

INCREMENTAL ENCODER
TECHNICAL DATA

Encoder type:	ELCIS mod. 478
Supply voltage:	8 to 24 Vcc
Current consumption:	120 mA max
Current output:	10 mA max
Output signal:	A phase- MONODIRECTIONAL A and B phase BIDIRECTIONAL
Response frequency:	100 KHz max
Number of pulses:	500 (others on request - max 2540)
Slew speed:	Always compatible with maximum motor speed
Operating temperature range:	from 0 to 70 °C
Storage temperature range:	from -30 to +85 °C
Ball bearing life:	1.5x10 ⁹ rpm
Weigth:	100 gr
Protection degree:	IP 67 (with protection and connector assembled)

Connectors:

MONODIRECTIONAL	RSF3/0.5 M (Lumberg)	male
	RKT3-06/5m (Lumberg)	female
BIDIRECTIONAL	RSF4/0.5 M (Lumberg)	male
	RKT4-07/5m (Lumberg)	female

Note: Female connectors cable length equal to 5 m.

Mounting

Any mounting position
 - Note the position of the case drain port (see below)

Install the motor properly
 - Mounting surface must be flat and resistant to bending

Min. tensile strength of mounting screws to DIN 267 Part 3 class 10.9

- Note the prescribed fastening torque

Pipes, pipe connections

Use suitable screws!
 - Depending on type of motor use either threaded or flange connection

Choose pipes and hoses suitable for the installation
 - Please note manufacturing data!

Before operation fill with hydraulic fluid
 - Use the prescribed filter!

Note: Two of the mounting screws must be precisely located/fitted if operation is started and stopped frequently or if high reversible frequencies exist.

Coupling

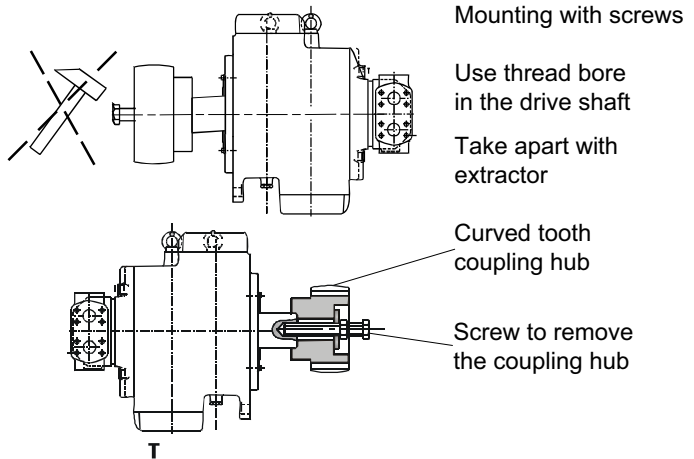

DRAIN AND FLUSHING LINK INSTALLATION EXAMPLES

Note: Install leakage line in such a way that motor **cannot** run empty.

T = Seal
 Y = Motor housing feeding point
 ← = Bleed

Note: Install leakage line in such a way that motor **cannot** run empty.

Low pressure case drain returns to tank

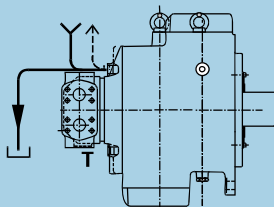

2 alternative case drain ports in the first cilinder row at 120° one from another

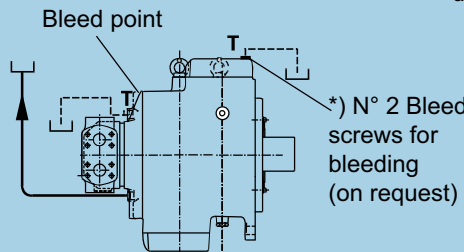

*) N° 2 Bleed screws for bleeding (on request)

Cooling circuits for heavy duty continuous operation

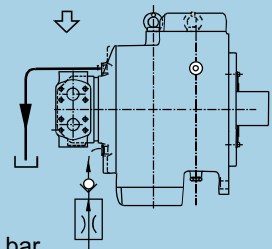

Flushing $p_{max} = 5 \text{ bar}$ with standard shaft seal

(release for bleeding)

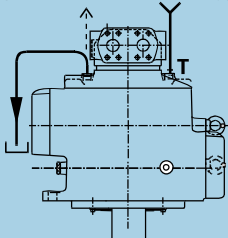

Overhead tank

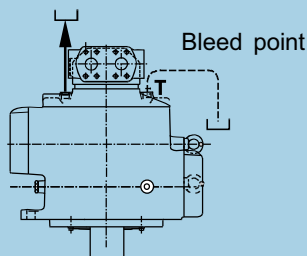

*) Bleed screw (on enquiry)

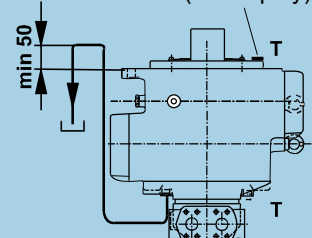

Choose drain port in order to allow the complete filling of the housing with hydraulic fluid.

*) Special designs for applications, where the equipment needs to be filled with oil.(e.g. in a salty atmosphere)

CODE

Example: MRT 7100P - D1 M1 F1 S1 N **

1. MRT 7100P - D1 M1 F1 S1 N **
SERIES

MRT	standard 250 bar max. continuous
MRTF - MRTE	expanded 210 bar max. continuous

2. MRT 7100P - D1 M1 F1 S1 N **

SIZE & DISPLACEMENT

P	code	MRT 7100 P	MRTF 7800 P	MRTE 8500 P
	Cm ³	7100,4	7808,8	8517,3
	code	MRT 9000 P	MRTF 9900 P	MRTE 10800 P
	Cm ³	9005,5	9903,9	10802,4
Q	code	MRT 14000 Q	MRTF 15500 Q	MRTE 16500 Q
	Cm ³	14010	15277	16543
	code	MRT 17000 Q	MRTF 18000 Q	MRT 19500 Q
	Cm ³	16759	18025	19508
	code	MRTE 20000 Q	MRTF 21500 Q	MRTE 23000 Q
	Cm ³	19788	21271	23034

3. MRT 7100P - D1 M1 F1 S1 N **
SHAFT

D1	spline DIN 5480 (see page 17)
F1	female spline DIN 5480 (see page 17-19)

4. MRT 7100P - D1 M1 F1 S1 N **

SPEED SENSOR OPTION

N1	none	
Q1	encoder drive (see page 20)	
C1	mechanical tachometer drive (see page 20)	
T1	tachogenerator drive (see page 20)	
M1	incremental Elcis encoder	Uni-directional
B1	(500 pulse/rev) (see page 20)	Bi-directional

5. MRT 7100P - D1 M1 F1 S1 N **

SEALS

N1	NBR mineral oil
F1	NBR, 15 bar shaft seal
V1	FPM seals
U1	no shaft seal (for brake)

6. MRT 7100P - D1 M1 F1 S1 N **
CONNECTION FLANGE

S1	SAE metric (see page 16-19)
G1	standard SAE 6000 psi metric (see page 16-19)
M1	SAE 6000 psi metric special timing (see page 18-19)

7. MRT - 7100P - D1 M1 F1 S1 N **
ROTATION

N	standard rotation (CW: inlet in A, CCW: inlet in B)
S	reversed rotation (CW: inlet in B, CCW: inlet in A)

8. MRT 7100P - D1 M1 F1 S1 N **
SPECIAL

**	space reserved to PARKER Calzoni
-----------	----------------------------------



FOR INFORMATION ABOUT SALES AND SERVICE LOCATIONS PLEASE CONTACT:

Parker Calzoni S.r.l.
Via caduti di sabbiano 15/17
40011 Anzola dell'Emilia
Bologna – Italy
Tel. +39.051.6501611
Fax. +39.051.736221
e-mail: infocalzoni@parker.com

or visit the websites:

www.parker.com



www.denisonhydraulics.com



YOUR LOCAL **PARKER CALZONI** REPRESENTATIVE

