



IPSTM



Linear Roller Systems

LR Series

LR Series Overview

The LR Series Belt Drive Roller System from Parker IPS

Linear Roller Series products from Parker IPS provide a high level of accuracy, load-bearing strength, and flexibility in a modular, low-cost package. These products utilize standard components and can adapt to a wide range of applications.

The foundation of the LR product line is the 40 Series of structural profiles that offer numerous mounting configurations. Profiles allowing maximum unsupported spans can be selected, saving valuable space and reducing overall system costs. Standard lengths of 6m and the ability to splice multiple sections allow configuration of nearly infinite stroke.

LRS Roller Bearings are made of 100 Cr6, ground and hardened steel, and provide low friction, long life, high speed, and heavy load capabilities. Bearing units are available as single and double roller types. Custom carriage configurations using multiple bearing units can be set up to meet off-the-shelf lead times.

The modular design allows for easy assembly, fast engineering, and a flexible platform capable of meeting even the most demanding application.

Market Applications

- **Material Handling**
- **Gantry Systems**
- **Visual Inspection**
- **Assembly and Transfer Lines**



- **Carriage loads to 2597 lbs**
- **Custom carriage options**
- **Speeds up to 5m/sec**
- **Easy mounting to AC motors**
- **Stroke lengths over 6m**
- **Instant motor/gearbox approval**



See page 7 for instant motor/gearbox approval.

Performance Overview

	LR 6	LR 14	LR 14HD	LR 25
Maximum Carriage Load N (lbs)	649 (146)	2,669 (600)	3,350 (753)	11,552 (2,597)
Pully Diameter (mm): Reversing Unit 40	47.75	47.75	47.75	47.75
Pully Diameter (mm): Reversing Unit 80	89.12	89.12	89.12	89.12
Pully Lead (mm/rev): Reversing Unit 40	150	150	150	150
Pully Lead (mm/rev): Reversing Unit 80	280	280	280	280
Maximum Travel Without Splice (mm)*	5900	5850	5840	5680
Minimum Travel (mm)	300	250	240	80
Maximum Drive Torque (Nm): Reversing Unit 40	20	20	20	20
Maximum Drive Torque (Nm): Reversing Unit 80	37	37	37	37
Maximum Belt Traction (lbs/belt)	575	575	575	575
Maximum Number of Belts	1	4	4	4
Maximum Speed (m/s)	5	5	5	5
Maximum Acceleration at No Load (m/s ²)	10	10	10	10
Repeatability (mm)	± .10	± .10	± .10	± .10

* Consult factory for long travel lengths.

Order Example

LR B 5 S0150 B 2000 R1 S1 F1 - A22A34

- ✓ **System Size**
 - LR 6 **A**
 - LR 14 **B**
 - LR 14HD **C**
 - LR 25 **D**
- ✓ **Extrusion Selection**
 - 40x40 Standard **1**
 - 40x40 Heavy **2**
 - 40x80 Standard **3**
 - 40x80 Heavy **4**
 - 80x80 Standard **5**
 - 80x80 Heavy **6**
 - 80x80 Super Heavy **7**
 - 80x160 Standard **8**
- ✓ **Bearing Configuration**
 - Double Bearing
(standard carriage length 150mm) **D**
 - Single Bearing
(enter total carriage length in mm) **Sxxxx**
- ✓ **Type**
 - Belt Drive **B**
 - Manual **M**
- ✓ **Travel**
 - Travel Length (mm) **xxxx**
- ✓ **Reversing Unit Combinations**
 - None (Manual Option Only) **R1**
 - Spline/Idler **R2**
 - Spline/Spline **R3**
 - Spline/8mm Bore **R4**
 - Idler/Idler **R5**
 - Idler/8mm Bore **R6**
 - 8mm Bore/8mm Bore **R7**
- ✓ **Adapter Shafts (couplers)[†]**
 - Blank – No Servicing **S1**
 - Special Servicing* **S2**
 - Shaft Type A, 0.375 in (9.525 mm) **S3**
 - Shaft Type B, 0.433 in (11mm) **S4**
 - Shaft Type C, 0.5 in (12.7mm) **S5**
 - Shaft Type D, 0.551 in (14mm) **S6**
 - Shaft Type E, 0.625 in (15.875mm) **S7**
 - Shaft Type F, 0.63" (16mm) **S8**
- ✓ **Accessories
(Replace # with
Quantity Required)**
 - A1#** Bumpers
 - A2#** Proximity Switch
 - A3#** Exciter Cam
 - A4#** Timing Belt Guide
 - A5#** Hand Crank Assembly**
 - A6#** Carriage Locking
Mechanism**
- ✓ **Adapter Flange[†]
(See Dim. Table)**
 - F1** Blank, No Servicing
 - F2** Universal Adapter
Special Servicing*
 - F3** Mounting Type A
 - F4** Mounting Type B
 - F5** Mounting Type C
 - F6** Mounting Type D
 - F7** Mounting Type E
 - F8** Mounting Type F
 - F9** Mounting Type G**

* Contact customer service for technical assistance
** Manual Systems only
[†] See page 7 for instant motor/gearbox approval selection

Adapter Flange Mount Type	Bolt Circle	Bolt Size	Pilot Dia.	Pilot Depth
A	98.40	M5	73.02	3.08
B	66.70	M4	38.10	1.60
C	75.00	M5	60.00	2.50
D	98.40	M6	73.02	3.08
E	100.00	M6	80.00	3.50
F	70.00	M4	50.00	3.05
G	90.00	M5	70.00	3.05

Note: All flange data in mm



Loading Capacity

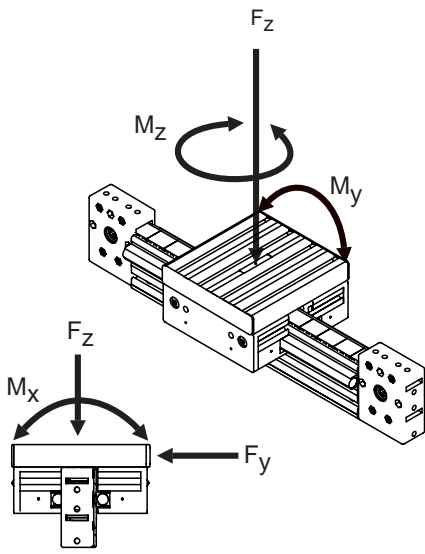

Static Moment Loads

Determine which moment loads are induced by the static load. Locate the center of gravity of the load and the length of the moment arm.

Moment Arm Lengths

Determine the moment arm lengths associated with each moment load by measuring the distance from the center of the load to the center of the carriage in each moment load direction.

Pitch Moment

When determining the pitch moment arm, it is necessary to consider the distance from the top of the load attachment plate to the center of the carriage bearings.

Operating Condition	Load Factor
Steady Load	1
Fluctuating Load	-
Low	1.4
Average	1.7
High	2

$$\text{Load Capacity} = \text{Load} * \text{Load Factor}$$

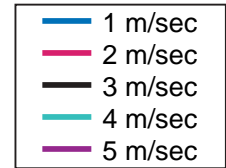

Key for charts on pages 4 and 5

LR6 Series

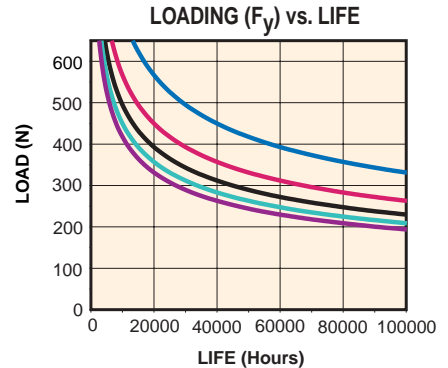
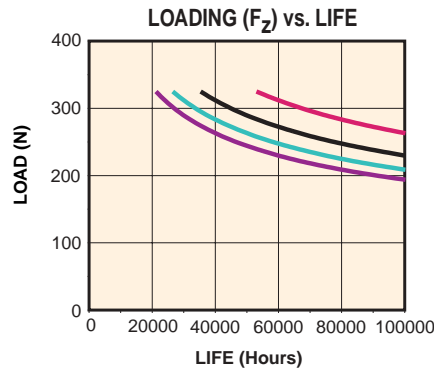

LR14/14HD Series

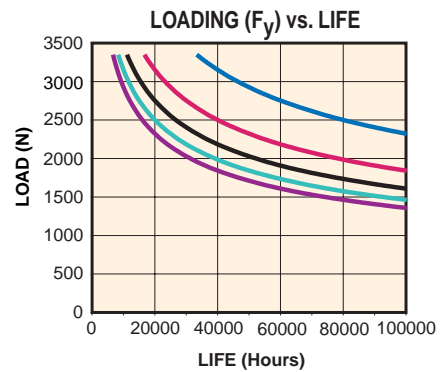
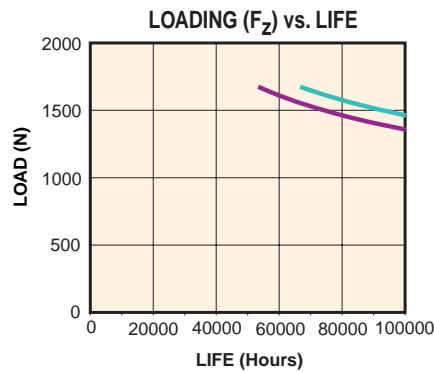

LR25 Series

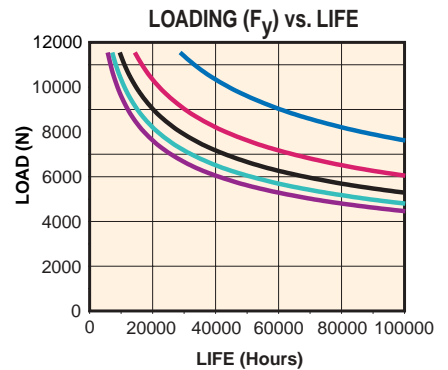
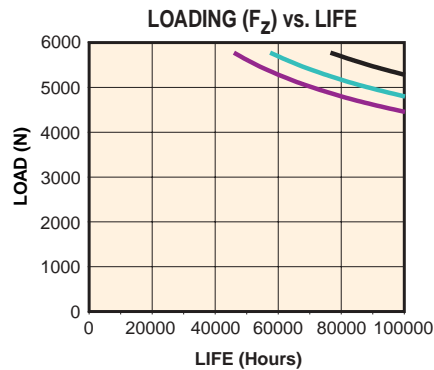

LR6 Series

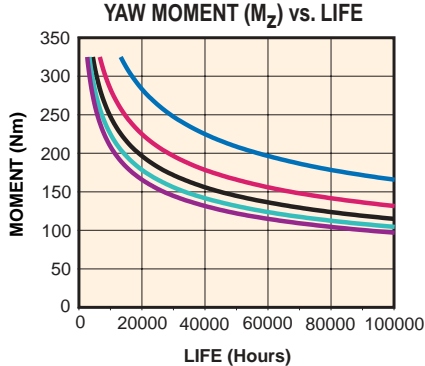
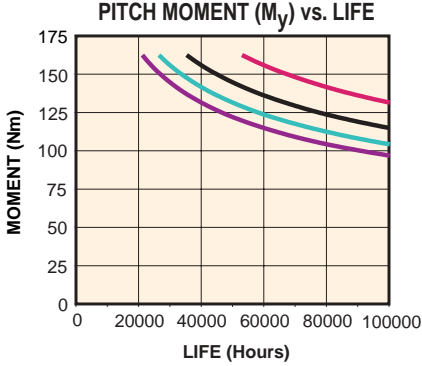
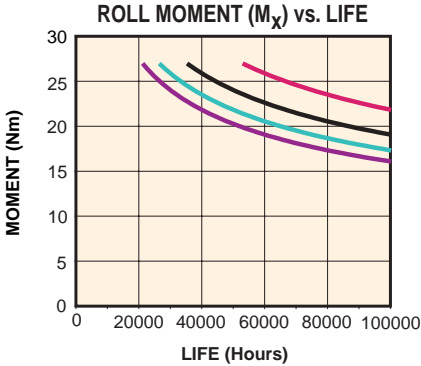

LR14 Series

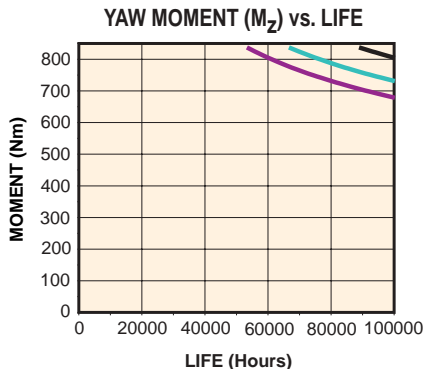
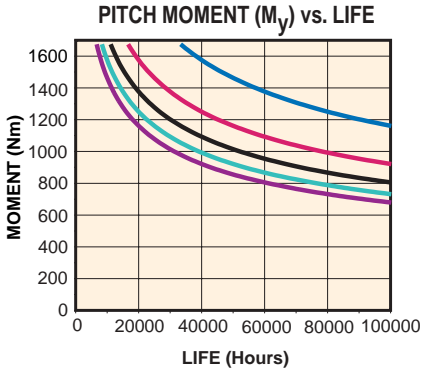
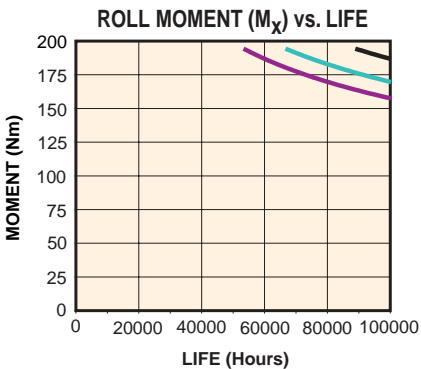

LR14HD Series

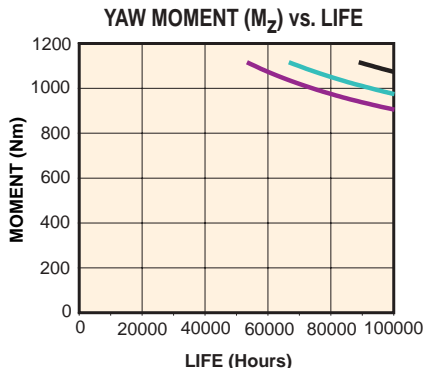
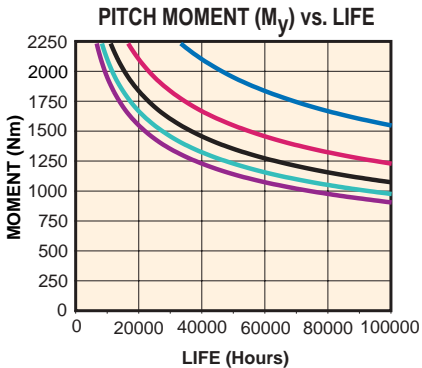
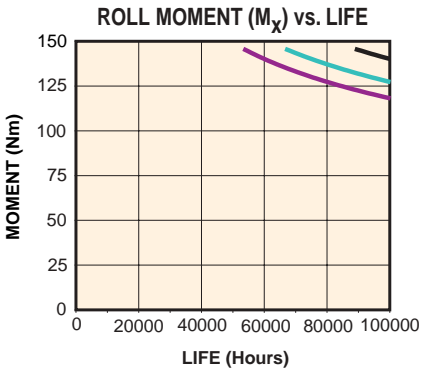

LR25 Series

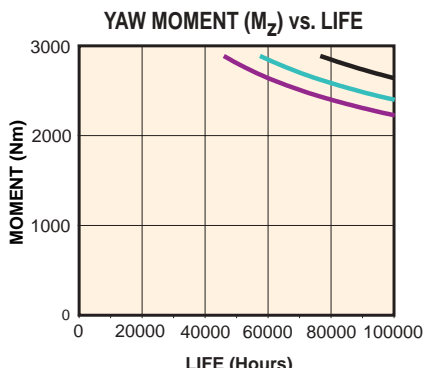
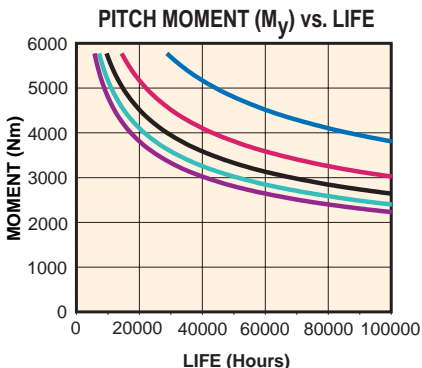
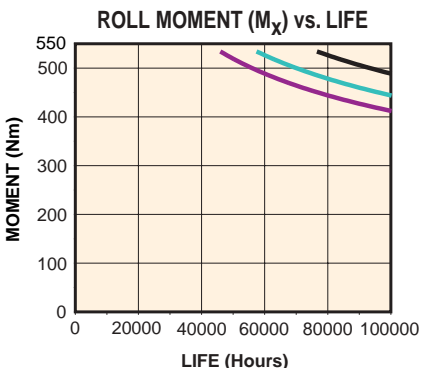

Carriage Mounting Detail

Carriage Mounting Detail

LR Series actuators offer unmatched carriage flexibility. Available in fixed length double bearing units or adjustable length single bearing units, the carriage can be tailored to meet specific load requirements. LR Series offers unmatched flexibility and solid performance.

Series	Carriage	Width	Length	Thickness	T-Slot
		A	B	C	D
LR6*	Single	80	L	16	40
	Double	80	92	16	40
LR14*	Single	160	L	28	40
	Double	160	142	28	40
LR14HD*	Single	160	L	28	40
	Double	160	160	28	40
LR25**	Double	320	312	28	40

*Based on 40mm Profile Width for LR6, LR14, and LR14HD

**Based on 80mm Profile Width for LR25 (Consult Factory for Single LR25)

Single Bearing Carriage

Double Bearing Carriage

LR6 Series

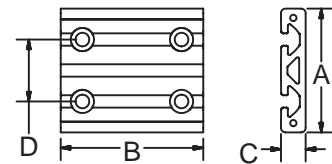
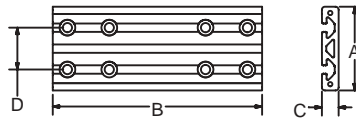

LR14 Series

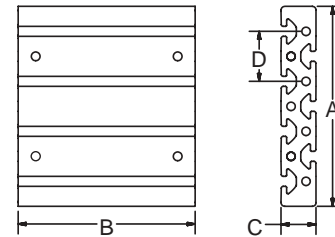
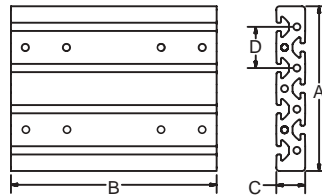

LR14HD Series

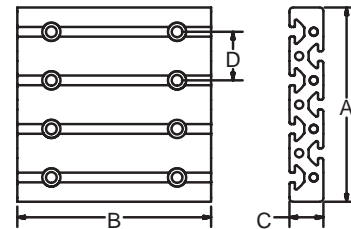

LR25 Series

Consult Factory

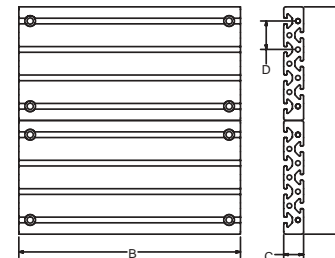

Carriage Orientation and Inertia Information

Carriage Orientation

A variety of carriage orientations are available thanks to the LR Series' modular design.

Options include multiple linked and multiple independent carriages on a single actuator and custom carriage lengths.

Selecting the proper profile for load support, and configuring the carriage to suit the specific load and application provides the benefits of a custom product without the additional costs and lead times.

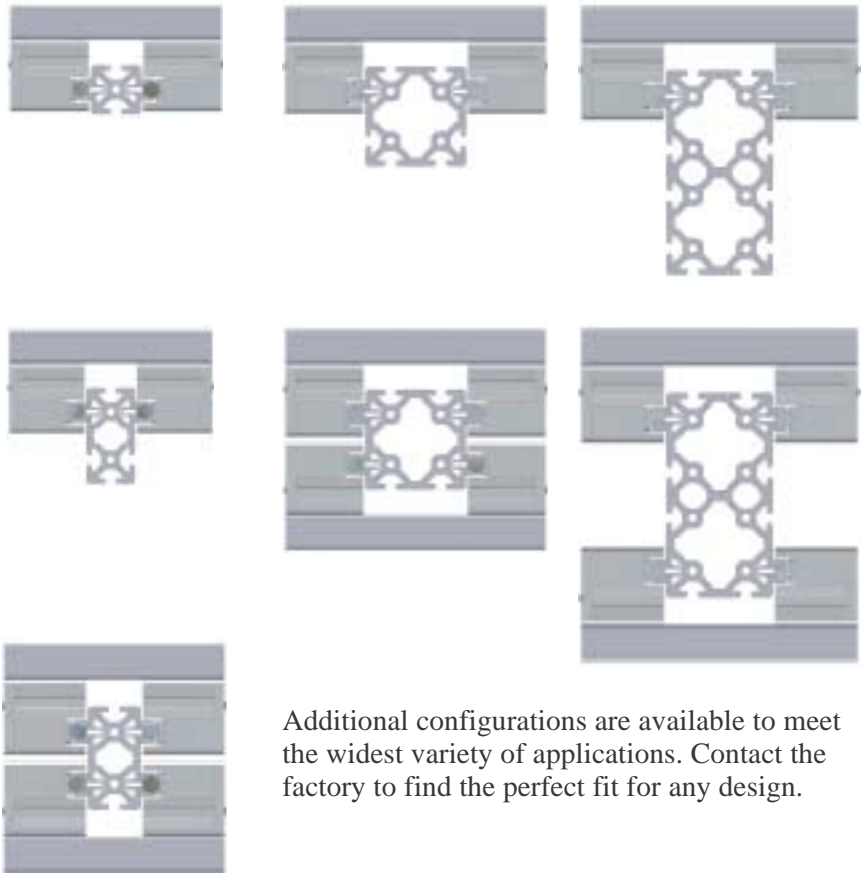

Additional configurations are available to meet the widest variety of applications. Contact the factory to find the perfect fit for any design.

Inertia Information

Linear Inertia (oz-in ²) vs Stroke (mm)										
Linear	100	200	300	500	750	1000	1500	3000	4000	6000
6	25.03	25.28	25.54	26.05	26.69	27.33	28.61	32.45	35.01	40.13
14	62.41	62.67	62.92	63.43	64.07	64.71	65.99	69.83	72.39	77.51
14HD	71.56	71.81	72.07	72.58	73.22	73.86	75.14	78.98	81.53	86.65
25	289.55	289.8	290.06	290.57	291.21	291.85	293.13	296.97	299.53	304.65

Linear Inertia (kg-cm ²) vs Stroke (mm)										
Linear	100	200	300	500	750	1000	1500	3000	4000	6000
6	4.58	4.62	4.67	4.76	4.88	5	5.23	5.93	6.4	7.34
14	11.41	11.46	11.51	11.6	11.72	11.84	12.07	12.77	13.24	14.18
14HD	13.09	13.13	13.18	13.27	13.39	13.51	13.74	14.44	14.91	15.85
25	52.96	53.01	53.05	53.15	53.26	53.38	53.61	54.32	54.78	55.72

Data calculated using a Reversing Unit 40 & Double Bearing Carriage

Deflection

Deflection Calculation

Parker IPS structural profiles are the foundation of the LR Series, providing unmatched flexibility and allowing for seamless integration of motion and structure. After selecting the LR Series type for appropriate carriage load capacity, the following formula will identify the profile configuration that is best suited for the application.

Deflection formula for length supported at both ends.

$$f = \frac{F * L^3}{48 E * I}$$

Where:

f = deflection in mm

F = load in N

L = free profile length in mm

E = Modulus of Elasticity in N/mm²

$$EAI = 70,000 \text{ N/mm}^2$$

I = Moment of inertia in mm⁴

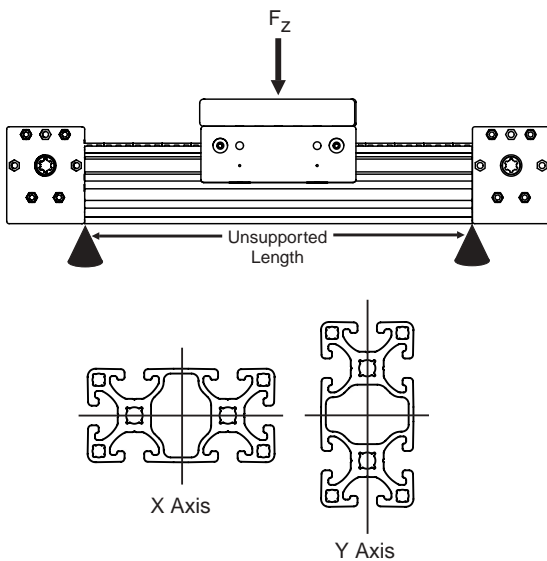

Deflection at Various Loads

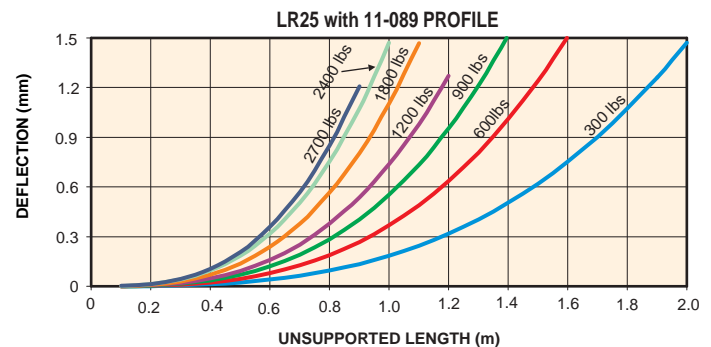
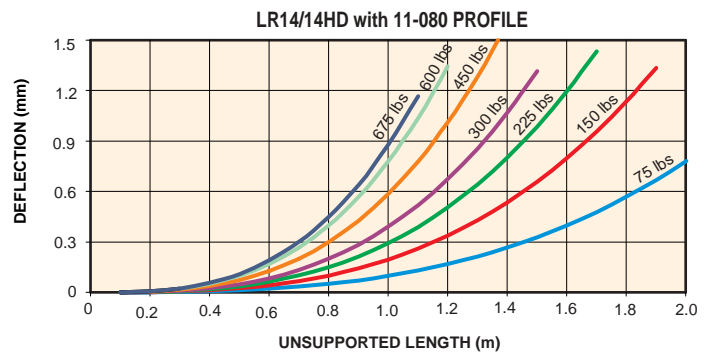
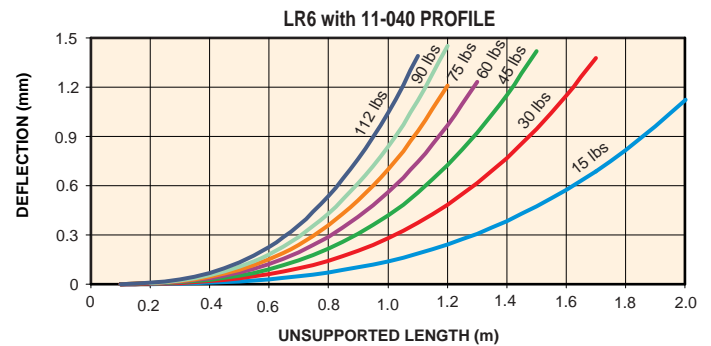

Profile Type	Series Compatibility			Moment of Inertia		Section Modulus	
	6	14/14HD	25	I_x [cm ⁴]	I_y [cm ⁴]	W_x [cm ³]	W_y [cm ³]
40x40 Standard	X			9.46	9.46	4.73	4.73
40x40 Heavy	X			14.18	14.18	7.09	7.09
40x80 Standard	X	X		71.79	17.23	17.99	8.62
40x80 Heavy	X	X		102	26.73	25.5	13.37
80x80 Heavy		X	X	185.2	185.2	46.3	46.3
80x80 Extra Heavy		X	X	215.85	215.85	53.96	53.96
80x160 Standard		X	X	922.5	271.1	115.3	67.8
80x160 Heavy		X	X	1106.92	343.37	138.37	85.84

Additional configurations are available for specific applications.



LR Series System Solutions

LR Series provides seamless integration with engineered structures from Parker IPS providing a more complete system solution.

Integrating LR Series products with Parker IPS structural systems provides clear advantages of welded steel construction.

- Welding distortion is eliminated producing a highly accurate finished product
- Anodized aluminum is corrosion resistant and does not require painting or maintenance.
- Shorter design to delivery lead times that other fabrication techniques
- Modifications and changes can be made through all stages of the project
- Integrating motion, control and structure streamlines engineering and supply chain channels.
- Fast, accurate 3D system drawings



LR Series and Parker IPS provide solutions to a wide variety of industries and applications including:

- Automotive
- Industrial Manufacturing
- Life-Sciences
- Packaging
- Material Handling
- Machine Building
- Aerospace
- Textiles
- Pulp & Paper

Think It, Design It, Built It

Motor/Gearbox Mounting and Optional Accessories

Motor/Gearbox Mounting

LR Series offers effortless motor and gearbox mounting and can accommodate a wide range of Servo and AC motors up to NEMA 56C as well as gearboxes. Connections are made using an Adapter Flange and Shaft.

These coupling components are available in preconfigured styles or as machinable blanks to accommodate connections not listed in the Motor/Gearbox Quick Selector on the following page.

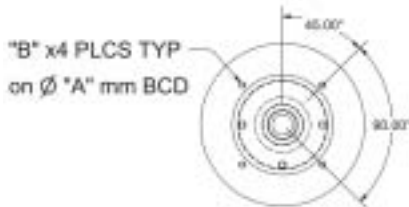
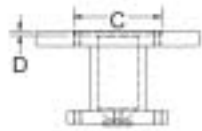

Part # Code	Bolt Circle "A"	Bolt Size "B"	Pilot Diameter "C"	Pilot Depth "D"
A	98.4	M5	73.02	3.5
B	66.7	M4	38.1	2
C	75	M5	60	3
D	98.4	M6	73.02	3.5
E	100	M6	80	4
F	70	M4	50	3.5
F	90	M5	70	3.5

Adapter Shaft Type	Shaft Diameter [in/mm]	Key Width [mm]	Shaft Height Over Key [mm]	Shaft Diameter Depth [mm]
	"A"	"B"	"C"	"D"
A	.375" [9.525]	M5	10.60	50.80
B	.433" [11]	M4	12.50	50.80
C	.500" [12.7]	M5	14.22	50.80
D	.551" [14]	M6	16.00	50.80
E	.625" [5.875]	M6	18.00	50.80
F	.630" [16]	M4	18.00	50.80

Accessories



Proximity Switches

Inductive proximity switches are actuated by a steel exciter cams pressed into the belt.

Sequence: PNP
 Indicator: LED
 Sensing Distance: 1.5mm
 Output: Normally Open
 Supply Voltage: 10-30 VDC

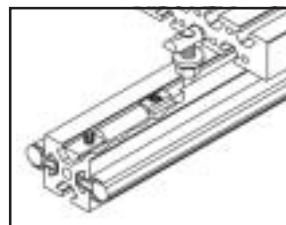

Bumpers

Bumpers define the mechanical limits of travel and can be located anywhere along the available stroke. A rubber shock absorber provides a cushioned end stop. Custom bumper assemblies are also available.

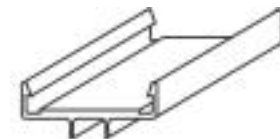

Timing Belt Guide

The Timing Belt Guide supports the 25 mm wide belt when long stroke lengths are required. The self lubricating UHMW material lowers belt friction and reduces wear, extending belt life.

This may interfere with clamping blocks, bumpers or other accessory devices.



Optional Accessories and Motor/Gearbox Selection



LR Series Accessories Include:

- Bumpers
- Proximity Switches
- Timing Belt Guides
- Adapter Shafts (Couplers) and Universal Flanges

Manufacturer	Motor/Gearbox Model #	Adapter Code	Flange Code
Allen-Bradley	1326Ax-B3, H-3xxx	D	E
	MPL-A45x, MPL-B45x	C	D
	MPL-x 310,320,330	E	E
	N-34xx	C	A
	Y-2xxx	D	F
AMP	HT34-486	C	A
Animatics	SM34xx	A	A
Baldor	All NEMA 48	C	-
	All NEMA 56	E	-
Bayside	PX34, RX34, NE34, NR34	C	A
ElectroCraft	N-34xx	C	A
	H-3xxx	D	E
Emerson	DXE208	A	B
	DXM-316, 340	D	E
	MGE 205, 208, 208CONS	A	B
	MGE-316, DXE-316	C	A
	MGM-340	D	E
	NTE-212-x, NTE-207-x	A	B
	NTE-3xx	C	A
GE Fanuc	STM13xx	C	A
Giddings & Lewis	HSM 307, 320	D	E
	NSM34xx	C	A
	YSM2xx	D	F
IDC	BN 31, 32	A	A
	P33x	E	A
Kollmorgen	MT(x)302 (NEMA 34)	A	A
	MT(x)304 (NEMA 34)	A	A
	MT(x)308 (NEMA 34)	C	A
	MTx 306, 308 (NEMA 100)	D	E
	MTx306 (NEMA-34)	C	A
MCG	AB34x	C	A
	ID34004	C	A
Mitsubishi	HC-KFS23(B), MF(S)23(B)	D	F
	HC-KFS43(B), MF(S)43(B)	D	F
	HC-PQ23, HC-PQ43	D	F
Motion Solutions	SLM075	E	A
MRV	MRV 31, 32, 33	C	A
Omron	R88M-U40030x	D	F
	R88M-W20030, R88M-W40030	D	F
	R88M-WP4xxx	D	G

Manufacturer	Motor/Gearbox Model #	Adapter Code	Flange Code
Pacific Scientific	H3xNR	A	A
	N31HR, N32HR	C	A
	N33HR, N33HR	C	A
	R30 (English & Metric)	C	A
	R30P (Metric)	C	A
Parker	APEX 603 ,605 ,606 ,610	D	E
	BE23x	A	B
	SM/SE 231, 232, 233 - L	A	B
	BE34x	C	A
	ES3xB	A	A
	J034x, N034x	C	A
	J092x, N092x, HDY92, HDX92	D	E
	MPM89x***6***	C	A
	MPM89x***7***	D	E
	MPP092x	E	E
	OEM-83-xxx, QM83	A	A
	PTN060	D	H
	RS 31, 32, 33	A	A
S, SX, SXF 83	A	A	
SMN082	D	E	
TS 31, 32	C	A	
TS33	E	A	
VS31, VS32	C	D	
ZETA83	A	A	
QuickSilver	QCI-34H-1, -2	C	A
	QCI-34H-3, -4	E	A
	QCI-34N-x	C	A
Slo-Syn	KML-09x, KMT-09x	C	A
Superior Electric	KML-09x, KMT-09x	C	A
Warner Electric	HIS35xx	C	A
	KML-09x, KMT-09x	C	A
Yaskawa	SGM-02, -03, -04	D	F
	SGMAH-02**F**	D	F
	SGMAH-04A**F**	D	F
	SGML-04A	D	F
	SGMP-02, -03, -04	D	G
	SGMPH-02, SGMP-02	D	G
	SGMPH-04A(B)	D	G

The adapter flange will accommodate motors through NEMA size 56. Additional mounting configurations are available. Contact Customer Service if your Motor or Gearbox is not listed.

*Engineering, fabrication and
inventory from Parker facilities
across North America*

Ohio

135 Quadral Drive
Wadsworth, OH 44281
330-336-3511
Fax: 330-334-3335

California

174 Lawrence Drive, Suite G
Livermore, CA 94551
925-456-2920
Fax: 925-456-2273

Massachusetts

19 Technology Drive
Auburn, MA 01501
508-832-0085
Fax: 508-832-4257

Minnesota

11170 North 60th Street
Stillwater, MN 55082
651-351-9330
Fax: 651-351-9334

Canada

160 Chisholm Drive
Milton, Ontario L9T3G9
905-693-3000
Fax: 905-876-1958

Mexico

Parker Hannifin Corporation
Eje Uno Norte No. 100
Parque Ind. Toluca 2000
Toluca, Edo. de C.P. 50100 Mexico
011 52 722 279 9300
011 52 722 275 4200
Fax: 011 52 722 279 9308

Electromechanical Actuator Products

Guided Cylinder Products

Rotary Actuator Products

Actuator Division
135 Quadral Drive
Wadsworth, OH 44281
330-336-3511
Fax: 330-334-3335
www.parker.com/actuator
email: actuatorsales@parker.com

Pneumatic Cylinders

Parker Hannifin Corporation

Actuator Division
550 South Wolf Road
Des Plaines, IL 60016
847-298-2400
Fax: 847-294-2655
www.parker.com/actuator
email: actuatorsales@parker.com

anything  **Possible.**TM

Parker Hannifin Corporation

Actuator Division
IPS Business Unit
135 Quadral Drive
Wadsworth, OH 44281 USA
Phone: 330-336-3511
Fax: 330-334-3335
www.parker.com/industrialprofile

Bulletin 1861
250 3/05 GL

© Copyright 2005
Parker Hannifin Corporation
All rights reserved.