

Pneumatic Division
 Richland, Michigan 49083
 269-629-5000

Installation & Service Instructions:
3FA105
P33 Modular Safety Exhaust Valve
ISSUED: September, 2017
Supersedes: None
 Doc.# 3FA105, EN170610, Rev. -

WARNING

To avoid unpredictable system behavior that can cause personal injury and property damage:

- **Disconnect electrical supply (when necessary) before installation, servicing, or conversion.**
- **Disconnect air supply and depressurize all air lines connected to this product before installation, servicing, or conversion.**
- **Operate within the manufacturer’s specified pressure, temperature, and other conditions listed in these instructions.**
- **Medium must be moisture-free if ambient temperature is below freezing.**
- **Service according to procedures listed in these instructions.**
- **Installation, service, and conversion of these products must be performed by knowledgeable personnel who understand how pneumatic products are to be applied.**
- **After installation, servicing, or conversion, air and electrical supplies (when necessary) should be connected and the product tested for proper function and leakage. If audible leakage is present, or the product does not operate properly, do not put into use.**
- **Warnings and specifications on the product should not be covered by paint, etc. If masking is not possible, contact your local representative for replacement labels.**

Safety Guide

For more complete information on recommended application guidelines, see the Safety Guide section of Pneumatic Division catalogs or you can download the **Pneumatic Division Safety Guide** at: www.parker.com/safety

1. About this documentation

These instructions contain important information for the safe and appropriate assembly and commissioning of the product.

Read these instructions all the way through, particularly section 6.1.1 “Safety instructions,” before working with the product.

Additional documentation:

- SISTEMA libraries
- DGUV (formerly BG) certificate: German professional association)
- Technical documents

For more information see last page for contact information, or visit www.parker.com/pdn/safetyvalve

- In addition, observe all applicable local and national regulations on accident prevention and on environmental protection.

1.1. Warning Notices in these Operating Instructions

In these operating instructions, warning notices precede sections with handling requirements which incur risks of personal injury or material damage.

Warnings are structured as follows:

SIGNAL WORD

Type or source of hazard!

Consequences

- Measures to avert danger
 - **Warning triangle:** Indicates a risk of fatal or severe injuries.
 - **Signal word:** Indicates the severity of the danger.
 - **Type or source of hazard:** States the type of danger or the source of the hazard.
 - **Consequences:** Describes possible consequences of ignoring the warning.
 - **Measures to avert danger:** Indicates how to avoid the danger. It is essential that the measures to avert danger are complied with.

- DANGER**
 Indicates an imminent and serious danger that will result in severe or even fatal injury if you fail to avoid it.
- WARNING**
 Indicates a possible danger that could result in severe or even fatal injury if you fail to avoid it.
- CAUTION**
 Indicates a danger that may result in minor to moderate injuries if you fail to avoid it.
- ATTENTION**
 Indicates potential property damage that may be incurred by the product or its surroundings if you fail to avoid it.

2. Product Identification

Date of manufacture and site of manufacture are permanently stamped:

Manufacturing site	Site abbreviation	Valve printing (example May 2016)
Parker USA	(L)	(5 16 L)
Parker GERMANY	(G)	(5 16 G)
Parker UK	(RB)	(5 16 RB)
Parker ASIA	(J)	(5 16 J)
Parker SOUTH AMERICA	(B)	(5 16 B)
Parker CHINA	(C)	(5 16 C)
Parker INDIA	(RCI)	(5 16 RCI)
See www.parker.com for Parker addresses.		

Product label identification & product key identification example, see page 6.

3. Prerequisites for Use of the Product

- Make these operating instructions available to the engineer and assembly technician of the machine/system in which the product will be used.
- Keep these operating instructions for the entire product life cycle.

3.1. Qualified Personnel

Assembly, installation, commissioning, maintenance, and decommissioning should only be carried out by qualified personnel that have the required knowledge of and experience in dealing with electrical and pneumatic control technology.

WARNING

FAILURE OR IMPROPER SELECTION OR IMPROPER USE OF THE PRODUCTS AND/OR SYSTEMS DESCRIBED HEREIN OR RELATED ITEMS CAN CAUSE DEATH, PERSONAL INJURY AND PROPERTY DAMAGE.

This document and other information from The Company, its subsidiaries and authorized distributors provide product and/or system options for further investigation by users having technical expertise. It is important that you analyze all aspects of your application, including consequences of any failure and review the information concerning the product or systems in the current product catalog. Due to the variety of operating conditions and applications for these products or systems, the user, through its own analysis and testing, is solely responsible for making the final selection of the products and systems and assuring that all performance, safety and warning requirements of the application are met.

The products described herein, including without limitation, product features, specifications, designs, availability and pricing, are subject to change by The Company and its subsidiaries at any time without notice.

EXTRA COPIES OF THESE INSTRUCTIONS ARE AVAILABLE FOR INCLUSION IN EQUIPMENT / MAINTENANCE MANUALS THAT UTILIZE THESE PRODUCTS. CONTACT YOUR LOCAL REPRESENTATIVE.

4. Package Contents

Items included:

- P33 Series valve
- Operating instructions

5. Service, Repair, and Maintenance

In case of technical problems or a required repair, please contact your local Parker representative. If used properly, the P33 Series valves will not require maintenance. Unless otherwise required, Parker recommends performing a functional test at least annually (see 8.1 Test Procedure).

6. Notes on Safety

The product has been manufactured according to the accepted rules of current technology.

There is risk of injury or damage if the following safety instructions and warnings given in this instruction manual are not observed.

6.1. Intended Use

The P33 Series of double valves are safety components designed and manufactured in accordance with Machinery Directive 2006/42/EC and bear the CE mark. The P33 Series double valves are redundant 3/2 valves that are designed to meet the needs and requirements of safe air supply/exhaust applications for machinery with pneumatic controls. Typically, these valves are implemented to meet the Category 4 and/or Performance Level e requirements of a machine's (or system's) safety circuit as determined by a risk assessment of the hazards and tasks required of employees that interact with the machine/system.

- See section 10 "Technical Data" for the standards and test values complied with and adhered to by the product. See the declaration of conformity for product-relevant EC directives.

The P33 Series valve is designed to supply air to a zone or entire machine/system until signaled to shut off and exhaust residual downstream pneumatic energy from the machine. Thus, reducing the hazards associated with the presence of residual energy during employee access and/or minor servicing. The safety function of the P33 Series valve is to shut off supply of pneumatic energy and to exhaust any pneumatic energy from downstream of the valve.

Note: The P33 Series valve cannot exhaust pneumatic energy from downstream of obstructions such as check valves and closed center function valves.

The P33 Series valves are designed for external monitoring for safe, redundant operation. The P33 Series valves are constructed of redundant, 3/2 poppet type valves, and have an overall function of a single solenoid pilot-operated, spring return valve. Each valve element in the P33 Series is equipped with a solid state pressure sensor. Monitoring both of these sensors on each actuation and de-actuation of the P33 Series valve provides a diagnostic coverage up to 99%. Monitoring of these sensors is to be done by an external monitoring system.

The P33 Series valves can also be purchased with a soft start module. The function of the soft start module is to, on energization, allow outlet pressure to increase at a slower than normal rate until it reaches approximately 50% of inlet pressure, at which point the valve will then open fully to finish filling the system at full flow rate. This feature can be used to lessen the shock of sudden, rapid pressurization of cylinders. This feature is especially useful where inline flow controls are placed into the cylinder control lines in the "meter out" mode. Flow controls mounted in this fashion do not operate sufficiently when the system is initially being refilled with compressed air after the system has been de-pressurized. This causes uncontrolled cylinder speed on the first actuation of the cylinder. The soft start feature can remedy this situation by gradually refilling the system. Thus, allowing cylinders to ease into place instead of slamming. When using the soft start feature, the time it takes for the outlet pressure to reach approximately 50% of inlet pressure can be changed by adjusting the flow control in the soft start module. Turning the flow control clockwise will increase the time it takes the outlet pressure to reach 50% of inlet pressure. Turning the flow control counter-clockwise will reduce this time. This time interval is directly affected by the volume of the system being filled. In larger volume systems the time to reach 50% will be longer than in systems with smaller volumes. It is important to note that the soft start feature only works when switching

the P33 Series valve on. The soft start feature does not affect the exhaust (safety) function of the valve.

6.1.1. Safety Function According to ISO 13849 and EN 692

P33 Series valves are designed in accordance with the requirements listed in ISO 13849-1 and -2. Their "fail-to-safe" safety function is ensured even in case of a fault within the valve (e.g., caused by wear, contamination, or similar situations).

The safety function of the 3/2 P33 Series valve is to only supply compressed air (pneumatic energy) to the machine/system when the two valve elements are actuated simultaneously, but to shut-off the supply and to exhaust any downstream compressed air when both valves are shut off or if only one of the two valves is actuated. A fault in the system where only one valve actuates when switching on or only one de-actuates when switching off prevents air from being supplied downstream and simultaneously exhausts any air that is already downstream. Monitoring of the two pressure sensors by the user's external safety monitoring system makes it possible to detect these fault situations and to shut off and prevent further electrical energization of the solenoids.

The control outputs of the safety system must be designed and constructed to meet the Category and/or Performance Level requirements of the safety system, as determined by the risk assessment of the machine. Normally, the outputs to the solenoids is a dual-channel output from a safety relay or safety PLC.

These products are designed and manufactured in accordance with the safety principles of ISO 13849-1 and EN 692.

6.1.2. Common Cause Failure – CCF

Common Cause Failures (CCF) are failures of different components, resulting from a single event. CCF are not to be confused with cascading faults or common mode faults. Common cause failures can cause loss of the safety function, especially in dual channel circuits where both channels could fail simultaneously due to a single event.

- Maintain compressed air quality, e.g., filtration, pressure regulation, lubrication.
- Avoid compressor oils that can cause valve seals to swell, soften, or otherwise deteriorate.
- Operate within prescribed temperature limits.
- Install the valve such that the normal stroke travel of the valve elements are perpendicular to the main direction of machine vibration and/or mechanical shock.
- Do not use a test pulse longer than allowed by the Technical Specifications.
- Avoid external magnetic fields.
- Do not plug the valve exhaust port.
- Use only high-flow, non-clogging silencers, with similar or higher specifications as Parker silencers.

6.1.3. Diagnostic Coverage

A diagnostic coverage of 99% is achievable through appropriate integration of the P33 Series valve into the safety control system. The monitoring system must check for the proper change of state of each valve pressure sensor (S1 & S2) with each change of state of the safety control system outputs to the valve solenoids (Sol 1 & Sol 2). Detection of a fault by the safety control system must trigger a shut-off of the safety controller's outputs to the valve solenoids (Sol 1 & Sol 2), see section 8.

6.1.4. Fault Modes

Note that normal operation requires that Sol 1 & Sol 2 be energized simultaneously for switching the P33 Series valve on, and de-energizing both Sol 1 and Sol 2 simultaneously for switching the P33 Series valve off. Faults that could occur during normal operation:

Sol 1 & Sol 2 energized simultaneously

S1 ON, S2 OFF
S1 OFF, S2 ON
S1 OFF, S2 OFF

Sol 1 & Sol 2 de-energized simultaneously

S1 ON, S2 OFF
S1 OFF, S2 ON
S1 ON, S2 ON

6.1.5. Foreseeable Misuse

⚠ WARNING

Risk of Injury!

- The product must be used exclusively as intended.

Foreseeable misuse includes:

- Use outdoors
- Bypassing the safety function or diagnostics
- Failing to utilize the onboard pressure sensors to verify valve operation on every cycle – energizing and de-energizing
- Allowing continued operation of the valve when one or both valve shifted signals (from pressure sensors) are not confirmed.
- Use in reverse operation (reversal of supply and exhaust air)
- Operation in low-demand mode per IEC 61508
- Operating at pressures below minimum operating pressure or above maximum operating pressure.

6.2. Responsibilities of the System Owner

- Observe the information on assembly and operating conditions listed in the operating instructions or the data sheet.
- Comply with the further requirements of ISO 13849 (e. g., CCF, DC, PLr, software) if you intend to use the product in higher categories (2 to 4).
- Make sure that the maximum number of switching cycles (B_{10D}) within the service life T_M is not exceeded. If the expected number of switching cycles for a component exceeds the B_{10D} value during its period of use, suitable replacement intervals have to be specified.
- Cycle the valve at least once a month to ensure its proper operation.
- Make sure that the fundamental and proven safety principles in accordance with ISO 13849 for implementation and operation of the component are complied with.
- Make sure that the permissible switch-on and switch-off pulses for feedback-free operation of the pneumatic devices are observed.
- If you operate the P33 Series valve together with an electric two-hand control, it must comply with the EN 574 standard. Selection and installation of this two-hand control must take place in accordance with the manufacturer's specifications.

6.3. Safety Instructions

- When implementing surge suppression measures, be sure to check whether or not this extends the valve shut off response time which could extend the machine stopping time.
- In case of high levels of machine vibration, use appropriate vibration-reducing elements when installing the valve.
- Supply the proper voltage as overvoltage situations can result in solenoid burnout.
- Make sure that the silencer's flow capacity is not restricted as this could affect system performance.
- If required, replace the silencer with a model equivalent or higher in specifications as Parker silencers.

7. Assembly and Installation

⚠ CAUTIONS

Risk of injury due to installation while pressurised or with live parts!

Installation while pressurized or with electrical power switched on can result in injuries due to sudden pressure build-up or electric shock.

- De-energize and de-pressurize the relevant system parts before installing the valves.
- Secure the system to prevent it being switched back on again.

ATTENTION

Indicates a danger that may result in minor to moderate injuries if you fail to avoid it.

Destruction of components!

Chemical substances can damage the surface, the markings and the seals of the device.

- Install the valve such that it is protected against the effects of chemicals.

Damage to the device through storage at incorrect temperatures!

The storage temperature represents the permissible ambient temperature and depends on the type of valve in question.

- Observe the temperature information in chapter 10 "Technical Specifications."

7.1. Mechanical Installation

If attaching to an installed Parker P32 or P33 Air Preparation Unit, use (2) Parker connection clamps. If installing as a stand-alone unit, use either (2) Parker connection clamp and bracket sets or install fittings directly into the inlet and outlet ports.

Visit www.parker.com/pdn/safetyvalve for more information.

7.2. Pneumatic Installation

Connect the compressed air supply to port 1. Connect port 2 to the downstream portion of the circuit.

7.3. Pneumatic and Electrical Connections

Electrical connections to the solenoids and sensors are made with male 5-pin M12 receptacles on the valve. See Pinouts on page 6. Female connectors and cables are sold separately. The cables and cable connections as well as the electrical control for the double valves must comply with the applicable safety regulations.

8. Commissioning and Operation

⚠ CAUTIONS

Damage to health due to loud noise!

Levels above 70 dB(A) may lead to damage to health!

- Always wear hearing protection when working on the product.

Before commissioning, the installation has to be carefully inspected by a qualified, trained professional.

Make sure that the technical specifications matches the operating criteria of the machine and/or the pneumatic system.

Always set the compressed air supply to a level that ensures that the minimum operating pressure is adhered to (see section 10 Technical Specifications).

8.1. Test Procedure

1. Only Solenoid A energized – Valve is faulted, supply is shut off, downstream air exhausts through port 3. Sensor A is off, sensor B is on.
2. Reset valve by de-energizing both solenoids – Valve is off, supply is shut off, and downstream air is exhausted through port 3. Sensors A & B are on.
3. Only Solenoid B energized – Valve is faulted, supply is shut off, downstream air exhausts through port 3. Sensor A is on, sensor B is off.
4. Reset valve by de-energizing both solenoids – Valve is off, supply is shut off, and downstream air is exhausted through port 3. Sensors A & B are on.
5. Solenoids A & B energized – Valve is on, air pressure is supplied downstream through port 2 and port 3 is shut off. Sensors A & B are off.
6. Solenoids A & B de-energized – Valve is off, supply is shut off, and downstream air is exhausted through port 3. Sensors A & B are on.

NOTE: Test 1 & 3 can only be conducted for solenoid configuration "A" (P33*B96A*E*)

Results from the test procedure other than those listed above could indicate a valve malfunction. See section 5, Service, Repair, and Maintenance.

Failure of the valve to shift synchronously leads to a fault in the P33 Series valve.

This could happen for a variety of reasons, such as:

- Defective piston seals,
- Main valve elements experiencing a switching delay due to dirt or resinous oil,
- Insufficient electrical signals to valve solenoids; suitable voltage not available,

- Receipt of signals at solenoids not synchronous,
- Pilot valves experiencing a switching delay due to damaged components, dirt, or resinous oil,
- Excessive water build-up in the valve.

9. Disconnecting and Removal

⚠ CAUTIONS

Risk of injury due to installation while pressurized or with live parts!

Installation while pressurized or with electrical power switched on can result in injuries due to sudden pressure build-up or electric shock.

- De-energize and de-pressurize the relevant system parts before installing the valves.
- Secure the system to prevent it being switched back on again.

Risk of injury due to disconnecting pressurized or live parts.

- Disconnecting a pneumatic component while the system is pressurized or while electrical power is supplied can result in injury or death due to sudden pressure release, unexpected movement, or electric shock.
- Isolate and lock out the electrical and pneumatic systems before disconnecting the valves.

10. Technical Specifications

Design:	Redundant, 3/2 Normally Closed, Dual Poppet.
Actuation:	Solenoid pilot operated with air assisted spring return. One solenoid per valve element (2 total) – both to be operated synchronously
Mounting type:	Inline mounted - modular/threaded
Mounting orientation:	Any, preferably vertical
Shock test (based on DIN EN 60068-2-27):	consult factory
Vibration test: (based on DIN EN 60068-2-6):	consult factory
Flow media:	Compressed air (inert gases), filtered in acc. with ISO 8573-1 (class 6/5 µm), with or without inline lubrication (mineral oils according to ISO 3448/ISO-VG, viscosity class 32)
Inlet pressure:	30 to 150 psig (2 to 10 bar)
Temperature:	Ambient 40° to 122°F (4° to 50°C) Media temperature 40° to 175°F (4° to 80°C) For temperatures below 40°F (4°C), the compressed air must be dried according to ISO 8573-3, class 7.
Standard voltages:	24 volts DC
Pilot solenoids:	According to VDE 0580 Rated for continuous duty.
Electrical connection type 5-pin M12	Enclosure rating according to DIN 400 50 IP65
Pilot Solenoids Power Consumption (each solenoid):	1.2 watts
Enclosure Rating:	According to DIN 400 50 IP65
Electrical Connections:	Two 5-pin M12 connectors. Enclosure rating according to DIN 400 50 IP65
Pressure Sensors (2 per valve):	Solid state
Pressure Sensors Current Consumption (each sensor):	<23mA (each without contacts)
Pressure Sensors:	B10D = 200x10°
B10D Value according to ISO 13849-1 and -2:	Service life parameter measured according to Parker Engineering Standard, Laboratory Test Procedures Section 8: B10D = 20 million cycles

Maximum Cycle Rate:	5 Hz measured without volume. The switching frequency decreases depending on the volume to be controlled.
Monitoring:	Dynamic, cyclical, external with customer supplied equipment. Monitoring should check state of both valve pressure sensors with any and all changes in state of valve control signals.
Sound Pressure Level [dB(A)]:	P33 = consult factory, maximum pulse sound pressure level at the loudest measuring point when exhausting the valve with a Parker silencer. The sound pressure level is influenced by the individual systems used for reduction of noise emissions. Do not restrict the valve exhaust. Use of the product without the silencer is not recommended.
Minimum Operation Frequency:	Once per month, to ensure proper function.

11. Disposal

Dispose of the valve in accordance with the applicable statutory regulations in your country.

⚠ CAUTIONS AND WARNINGS

PRE-INSTALLATION or SERVICE

1. Before servicing a valve or other pneumatic component, be sure that all sources of energy are turned off, the entire pneumatic system is shut off and exhausted, and all power sources are locked out (ref: OSHA 1910.147, EN 1037).
2. All Parker products, including service kits and parts, should be installed and/or serviced only by persons having training and experience with pneumatic equipment. Because any installation can be tampered with or need servicing after installation, persons responsible for the safety of others or the care of equipment must check every installation on a regular basis and perform all necessary maintenance.
3. All applicable instructions should be read and complied with before using any fluid power system in order to prevent harm to persons or equipment. In addition, overhauled or serviced valves must be functionally tested prior to installation and use. If you have any questions, call your nearest Parker location listed on www.parker.com.
4. Each Parker product should be used within its specification limits. In addition, use only Parker parts to repair Parker products.

WARNING: Failure to follow these directions can adversely affect the performance of the product or result in the potential for human injury or damage to property.

FILTRATION and LUBRICATION

5. Dirt, scale, moisture, etc. are present in virtually every air system. Although some valves are more tolerant of these contaminants than others, best performance will be realized if a filter is installed to clean the air supply, thus preventing contaminants from interfering with the proper performance of the equipment. Parker recommends a filter with a 5-micron rating for normal applications.
6. All standard Parker filters and lubricators with polycarbonate plastic bowls are designed for compressed air applications only. Do not fail to use the metal bowl guard, where provided, to minimize danger from high pressure fragmentation in the event of bowl failure. Do not expose these products to certain fluids, such as alcohol or liquefied petroleum gas, as they can cause bowls to rupture, creating a combustible condition, hazardous leakage, and the potential for human injury or damage to property. Immediately replace a cracked, or deteriorated bowl. When bowl gets dirty, replace it or wipe it with a clean dry cloth.
7. Only use lubricants which are compatible with materials used in the valves and other components in the system. Normally, compatible lubricants are petroleum based oils with oxidation inhibitors, an aniline point between 180°F (82°C) and 220°F (104°C), and an ISO 32, or lighter, viscosity. Avoid oils with phosphate type additives which can harm polyurethane components, potentially leading to valve failure which risks human injury, and/or damage to property.

AVOID INTAKE / EXHAUST RESTRICTION

- 8. Do not restrict the air flow in the supply line. To do so could reduce the pressure of the supply air below the minimum requirements for the valve and thereby cause erratic action.
- 9. Do not restrict a valve's exhaust port as this can adversely affect its operation. Exhaust silencers must be resistant to clogging and must have flow capacities at least as great as the exhaust capacities of the valves. Contamination of the silencer can result in reduced flow and increased back pressure.

WARNING: Parker expressly disclaims all warranties and responsibility for any unsatisfactory performance or injuries caused by the use of the wrong type, wrong size, or an inadequately maintained silencer installed with a Parker product.

POWER PRESSES

- 10. Mechanical power presses and other potentially hazardous machinery using a pneumatically controlled clutch and brake mechanism must use a press control double valve with a monitoring device. A double valve without a self-contained monitoring device should be used only in conjunction with a control system which assures monitoring of the valve. All double valve installations involving hazardous applications should incorporate a monitoring system which inhibits further operation of the valve and machine in the event of a failure within the valve mechanism.

ENERGY ISOLATION/EMERGENCY STOP

- 11. Per specifications and regulations, Parker P33 and P33 with soft start operation products are defined as energy isolation devices, NOT AS EMERGENCY STOP DEVICES.

Dimensions mm (inches)

Externally Monitored (with Soft Start)

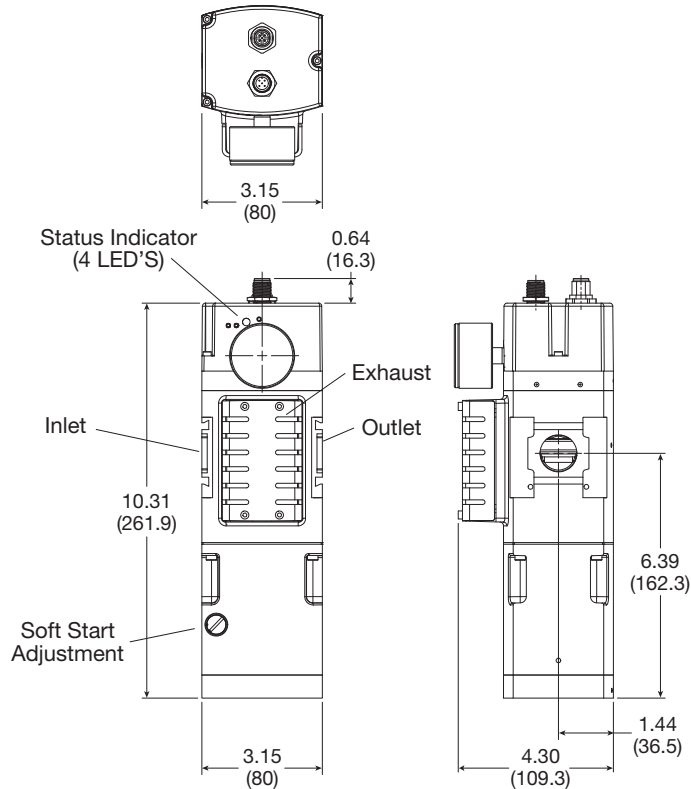

Flow rates

Port size	Description	Cv	
		1 - 2	2 - 3
3/4	3/4" with Soft Start	4.1	7.5
	3/4" without Soft Start	4.3	7.5

Schematics

Simplified

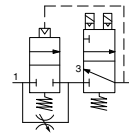

With optional soft start module

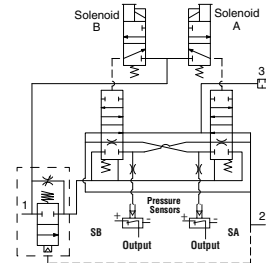

Simplified

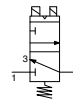

Without soft start module

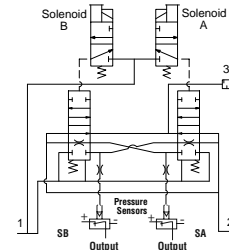

Externally Monitored (without Soft Start)

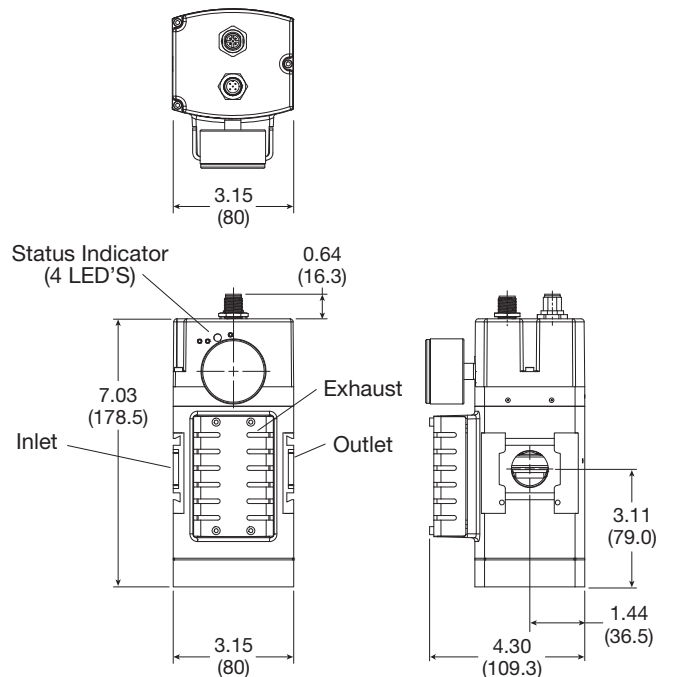

Solenoid M12 Pinouts

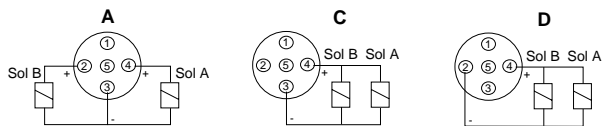

Pressure Sensor M12 Pinouts

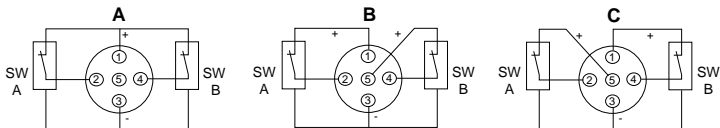

Ordering Information

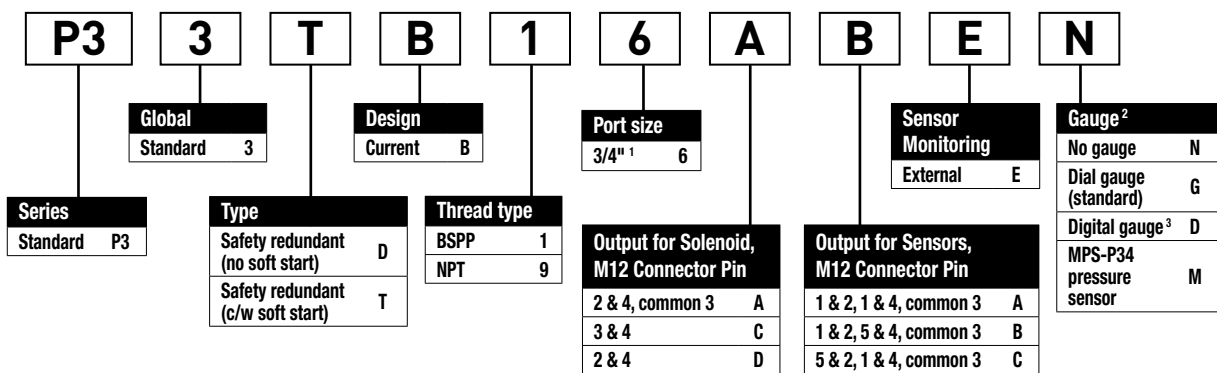

- Notes:
1. For 1/2" connections use 1/2" port blocks on standard 3/4" housing.
 2. Gauges shipped loose.
 3. Digital gauge not available on BSPP version.
- Note: Mounting hardware and port blocks are sold separately.

Product Label Identification

Model No: P33TB96AAED
 Pressure: 30 to 150 PSIG (2 to 10 bar)
 Voltage: 24V DC / 1.2 W per coil

