

Modular Lean Solutions

Versatile Display Stands for Lean
Team Tracking and Communication Boards

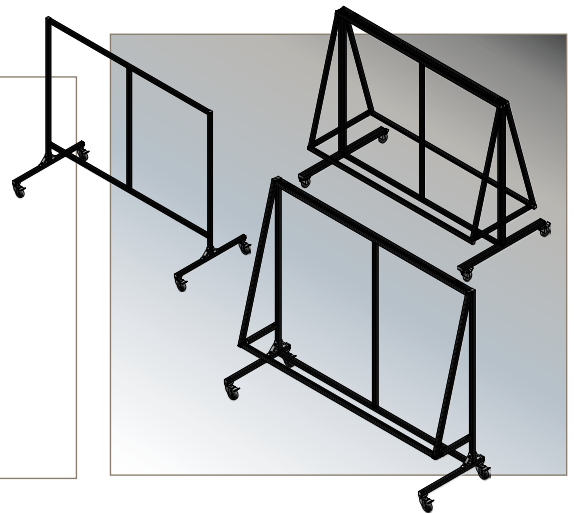

Communicate. Analyze. Execute.

Visual management and team improvement boards are lean fundamentals and should be deployed across all levels and processes of an organization to maximize customer satisfaction, efficiency, effectiveness and safety.

In a lean workplace environment, visual management and team improvement boards make the status of the current condition obvious at a glance. Utilizing visual information helps us to run our businesses by creating rapid recognition of problems (waste).



Analysis of displayed data intuitively accelerates and supports the problem-solving. Visual representation of the

PDCA cycle guides teams through effective execution to eliminate *muda* and generate improvements.

Effortless, Mobile, Modular...

Contact Information:

Parker Hannifin Corporation
Electromechanical Automation Division
email ipsorders@parker.com
www.parkermotion.com/ips

Two Locations to Serve You:

135 Quadral Drive
Wadsworth, OH 44281
Phone 800.333.4932
Fax 330.334.2350

5500 Business Park Drive
Rohnert Park, CA 94928
Phone 800.358.9070
Fax 707.584.8029

Implementing a visual workplace requires a significant time and effort investment to setup and to maintain.

To simplify your lean and quality journey, Parker has created a series of standard, mobile communication board stands using our modular Industrial Profile System (IPS) T-slot aluminum framing system.

These pre-configured designs simplify your implementation by providing a single part number to order your board and mobile stand. Units can be provided either fully assembled or as fully machined kits for easy on-site assembly.

Choose the configuration tailored to the specific needs of your application:

- **Vertical, angled and double angled display styles**
- **Two sizes: 3 x 4 or 4 x 6 feet**
- **Choice of white magnetic dry erase, black push pin, or mount your own board**

With Parker Modular Lean Solutions, there's no need to spend time designing your tracking centers or communication boards. Simply order for quick delivery and start using immediately to uncover problems and drive solutions.



ENGINEERING YOUR SUCCESS.

Modular Lean Solutions

Team Tracking and Communication Boards and Stands

Vertical Display

Size H x W (ft)	Display Board Material	Part Number	
		Kit	Assembled
3 x 4	White Magnetic	70-134-WK	70-134-WA
	Black Push Pin	70-134-PK	70-134-PA
	No Board	70-134-NK	70-134-NA
4 x 6	White Magnetic	70-146-WK	70-146-WA
	Black Push Pin	70-146-PK	70-146-PA
	No Board	70-146-NK	70-146-NA

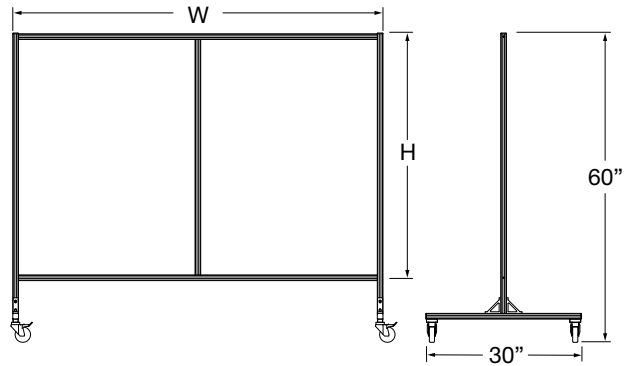

Angled Displays

Size H x W (ft)	Display Board Material	Part Number	
		Kit	Assembled
3 x 4	White Magnetic	70-234-WK	70-234-WA
	Black Push Pin	70-234-PK	70-234-PA
	No Board	70-234-NK	70-234-NA
4 x 6	White Magnetic	70-246-WK	70-246-WA
	Black Push Pin	70-246-PK	70-246-PA
	No Board	70-246-NK	70-246-NA

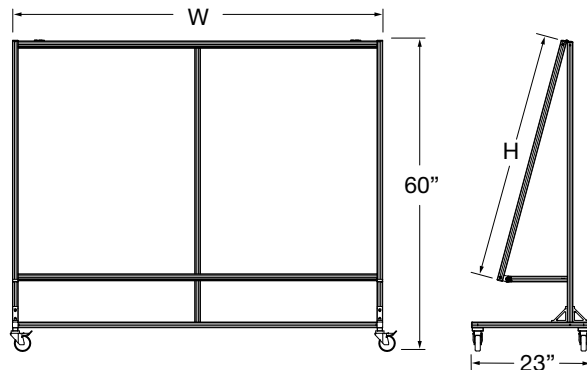

Double Angled Displays

Size H x W (ft)	Display Board Material	Part Number	
		Kit	Assembled
3 x 4	White Magnetic	70-334-WK	70-334-WA
	Black Push Pin	70-334-PK	70-334-PA
	No Board	70-334-NK	70-334-NA
4 x 6	White Magnetic	70-346-WK	70-346-WA
	Black Push Pin	70-346-PK	70-346-PA
	No Board	70-346-NK	70-346-NA

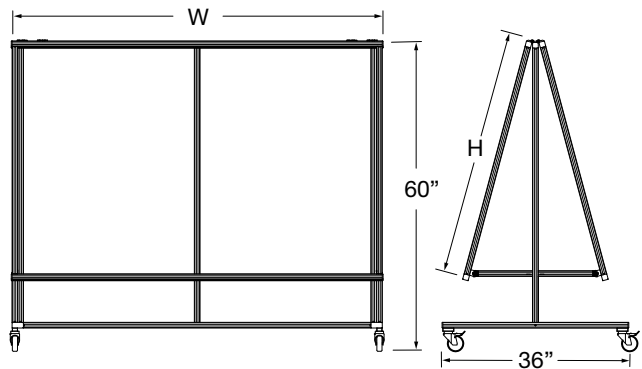

Standard designs don't solve your problem?

Contact applications engineering at IPSQuotes@parker.com or call 800.333.4932

