



aerospace  
climate control  
electromechanical  
**filtration**  
fluid & gas handling  
hydraulics  
pneumatics  
process control  
sealing & shielding



# 50P Series

High Pressure Filters



ENGINEERING YOUR SUCCESS.

# 50P Series

## Applications

### Applications for 50P series filters

- Automotive specified equipment
- Hydrostatic transmission circuits
- Servo and proportional controls
- Offshore drilling rigs
- Mining equipment
- Power units

The design objective for all Parker filters is to achieve a sensible balance between cost and performance. We use state of the art technology to arrive at innovative yet practical designs. Designs which are cost effective for OEM's and users alike.

The 50P series allows you to customize each filter to closely match your needs. Choose the options which best fit your application. No need to waste money on features you don't need.

The 50P series filters are base mounted, which provides several possible advantages. The bowl up mounting makes servicing the elements quick and easy. Simply remove the top cover to access the element. A drain port is provided to allow oil be removed from filter prior to element servicing. This design reduces the possibility of oil spillage and injury to maintenance personnel.

The 50P series has optional manifold porting for space saving design that reduces the number of fittings and potential leak points. The porting is also designed to match the installation of many other manufacturers. Most important, the 50P series meets the SAE HF4 automotive standard.

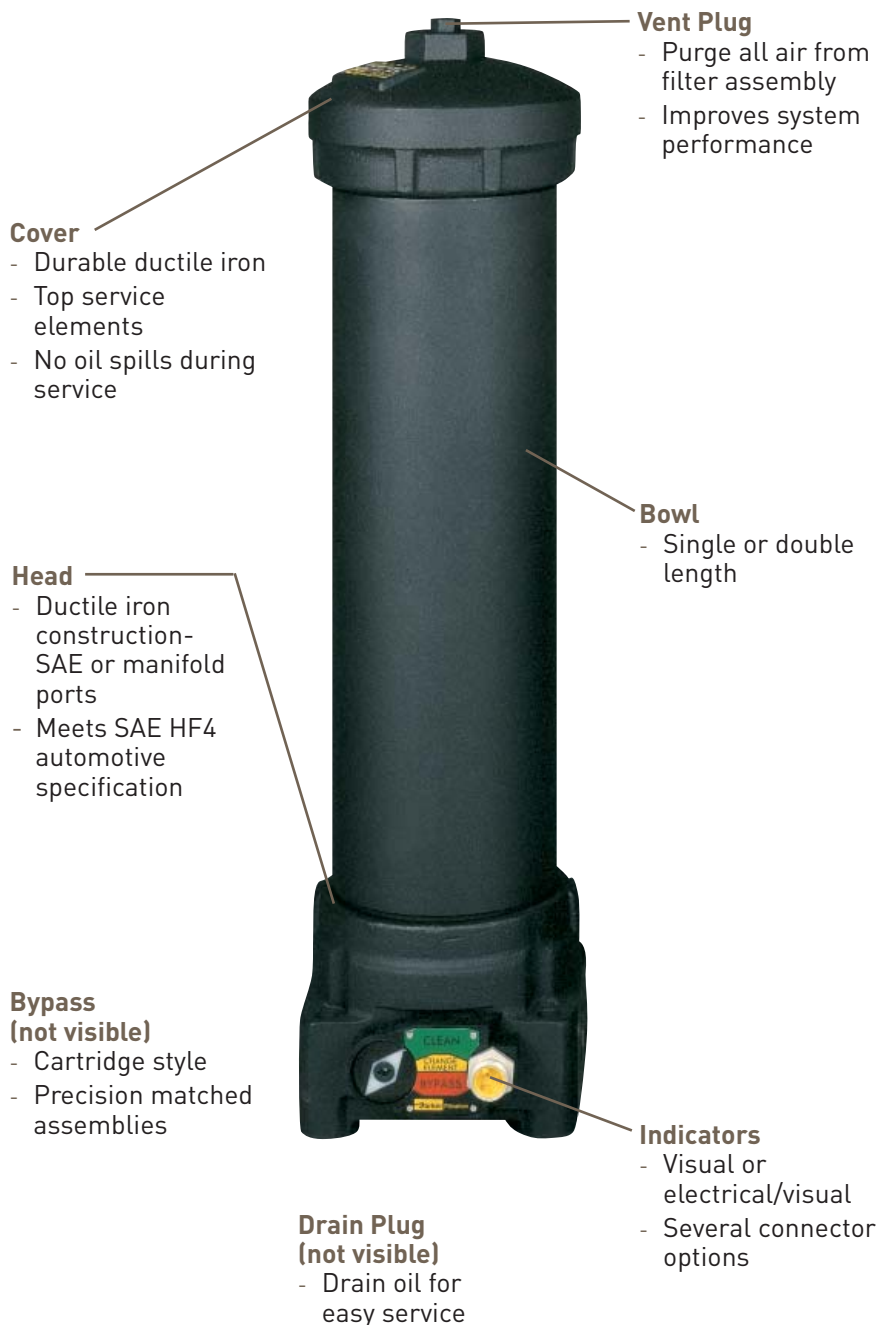

# 50P Series

## Features

### O-Ring Seal

- Positive sealing for optimum element efficiency

### Plastic End Caps

- Excellent corrosion protection
- Laser marked for clear long lasting identification



### Microglass III Media

- Multi-layer for high capacity and high efficiency
- Four different micron sizes available
- Wire reinforced to prevent pleat bunching

### Spiral Support Cylinders (Not Visible)

- High strength consistent support
- Continuous length eliminates leak points and increases surface area

Meets SAE HF4 specification for automotive uses

Feature	Advantage	Benefit
<ul style="list-style-type: none"> <li>• Base mounted filter</li> </ul>	<ul style="list-style-type: none"> <li>• No brackets required for installation</li> </ul>	<ul style="list-style-type: none"> <li>• Reduced installation costs</li> </ul>
<ul style="list-style-type: none"> <li>• Top access cover</li> </ul>	<ul style="list-style-type: none"> <li>• Remove element from top</li> <li>• Lighter then removing entire bowl</li> </ul>	<ul style="list-style-type: none"> <li>• No oil mess</li> </ul>
<ul style="list-style-type: none"> <li>• Visual and electrical indicators</li> </ul>	<ul style="list-style-type: none"> <li>• Know exactly when to service elements</li> </ul>	
<ul style="list-style-type: none"> <li>• Drain port</li> </ul>	<ul style="list-style-type: none"> <li>• Drain all oil from assembly prior to servicing</li> </ul>	<ul style="list-style-type: none"> <li>• Eliminates cross contamination</li> </ul>
<ul style="list-style-type: none"> <li>• Vent port</li> </ul>	<ul style="list-style-type: none"> <li>• Purges all trapped air in filter</li> </ul>	<ul style="list-style-type: none"> <li>• Get the maximum performance from elements</li> <li>• Prevents a "spongy" system</li> </ul>
<ul style="list-style-type: none"> <li>• Multipass tested elements (per ANSI/NFPA T3.10.8.8 R1-1990)</li> </ul>	<ul style="list-style-type: none"> <li>• Element performance backed by recognized test standards</li> </ul>	<ul style="list-style-type: none"> <li>• Elements selected will have consistent performance levels</li> </ul>
<ul style="list-style-type: none"> <li>• Microglass III elements</li> </ul>	<ul style="list-style-type: none"> <li>• Multi-layer media</li> <li>• Wire reinforced pleats</li> </ul>	<ul style="list-style-type: none"> <li>• High capacity with high efficiency</li> <li>• No performance loss from pleat bunching</li> </ul>

# 50P Series

## 50PR Reverse Flow Filter

The 50PR was designed specifically for hydrostatic transmission loops because of its capability to handle reverse flow.

Closed circuit HSTs frequently reverse direction causing flow to reverse in the fluid lines. Pressure filters installed between pump and motor must be able to handle reverse flow without having contaminant washed off of the elements and back into the system. To prevent such an occurrence, the filters require the use of internal check valves to direct the flow through the element in one direction and around the element in the other. Parker's internal check valve design minimizes additional pressure loss and eliminates the cost associated with external valves and fittings. Also the internal design keeps the envelope dimensions of the filter to a minimum as can be seen on the installation drawing.

### Sizing 50PR Filter Assemblies

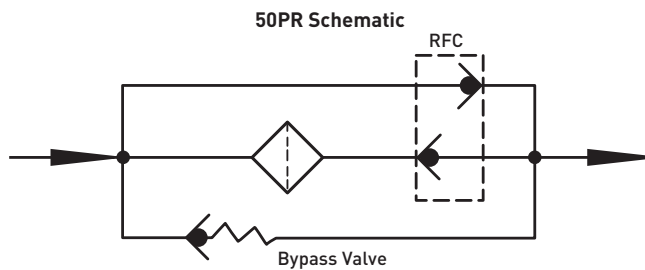

To accurately determine the total pressure loss that will be seen when used in your system, the following steps should be taken.

1. Examine the "Flow vs. Pressure" curve below. Find the pressure drop for the maximum system flow on the forward flow curve. Record this value as "housing with check valve pressure loss."
2. Examine the appropriate pressure loss curve for the media and bowl length combination. These curves are found in the Element Performance Data section.
3. Find the pressure drop for the maximum flow rate through the filter and record this value as "element pressure loss."
4. Find the empty housing pressure drop for the maximum flow rate through the filter and record this value as "empty housing pressure loss."
5. Add the values obtained in steps 1 and 3, then subtract out the value from step 4. The resultant pressure loss should not exceed 1/3 of the bypass valve or indicator you intend to select. If this ratio exceeds 1/3, then a double length housing or other media grade may need to be considered.

Contact the Hydraulic Filter Division if there is any doubt as to the total pressure loss you have calculated.

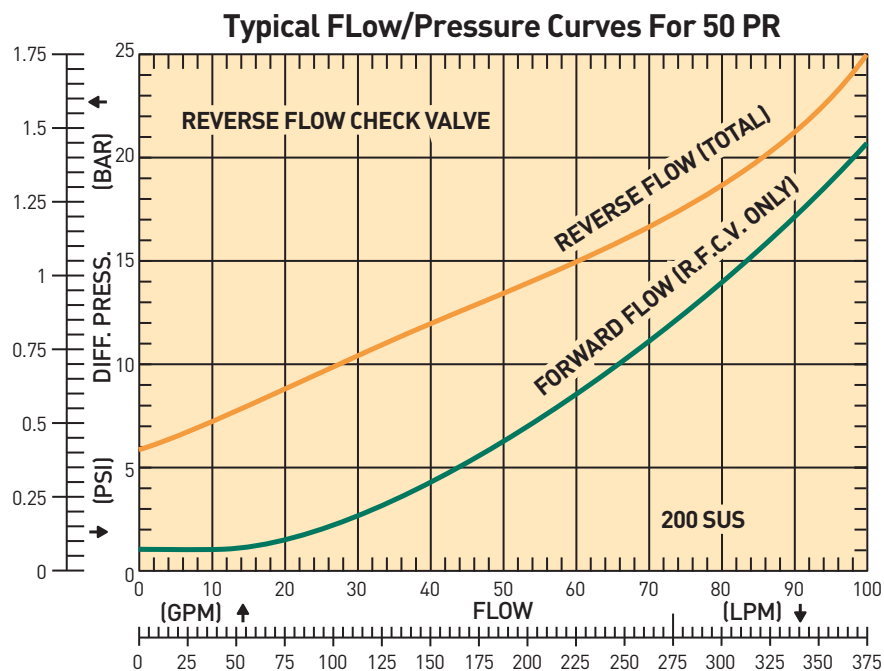

# 50P Series

## 50P-1 Element Performance

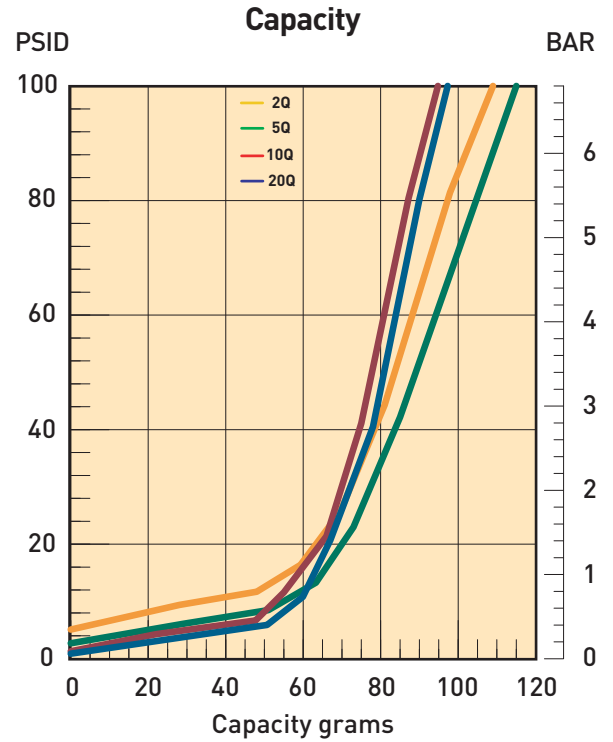
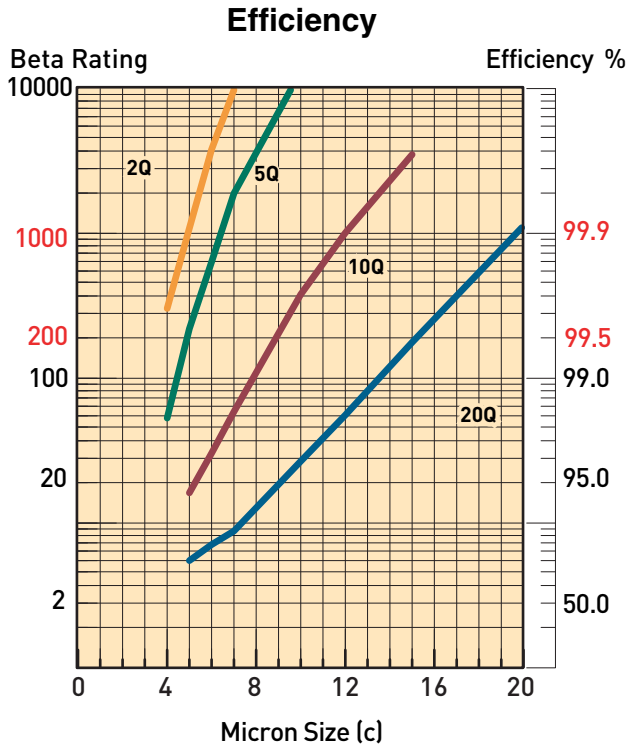

Results typical from Multi-pass tests run per test standard ISO 16889 @ 50 gpm to 100 psid terminal - 10 mg/L BUGL  
Refer to Appendix on pages 264-265 for relationship to test standard ISO 4572.

## Flow vs. Pressure Loss

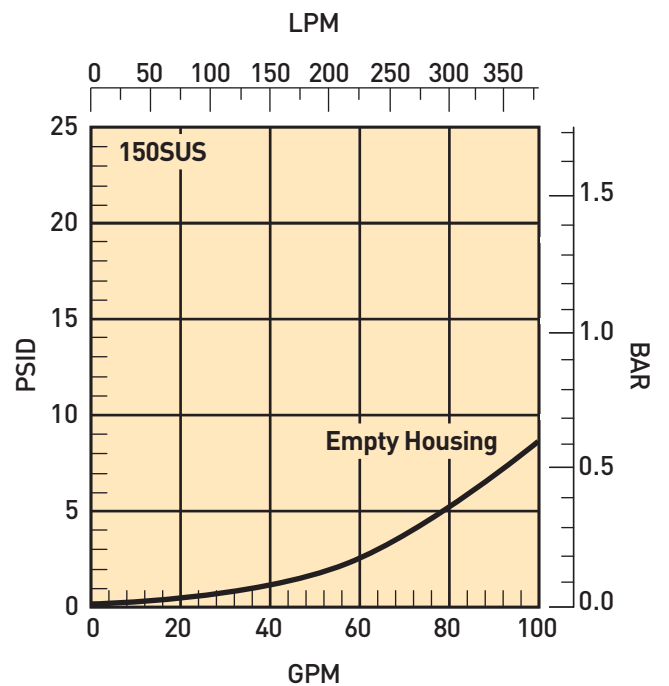
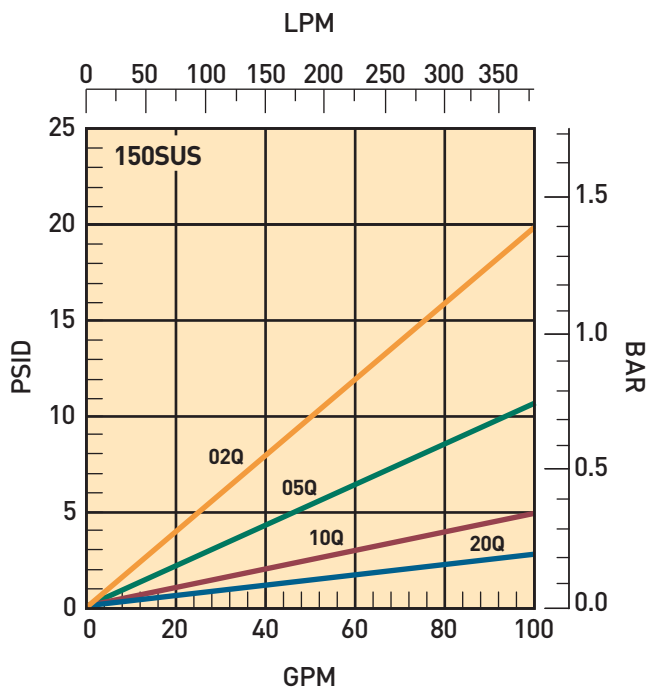

# 50P Series

## 50P-2 Element Performance

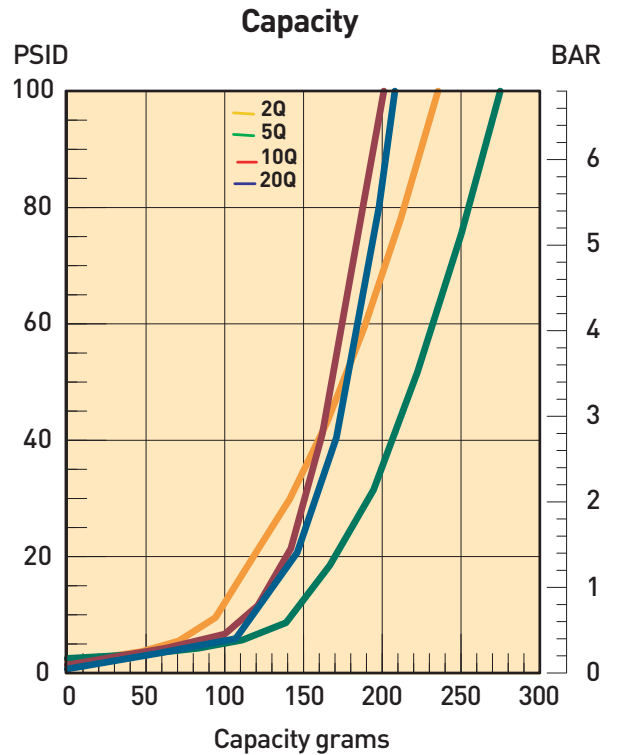
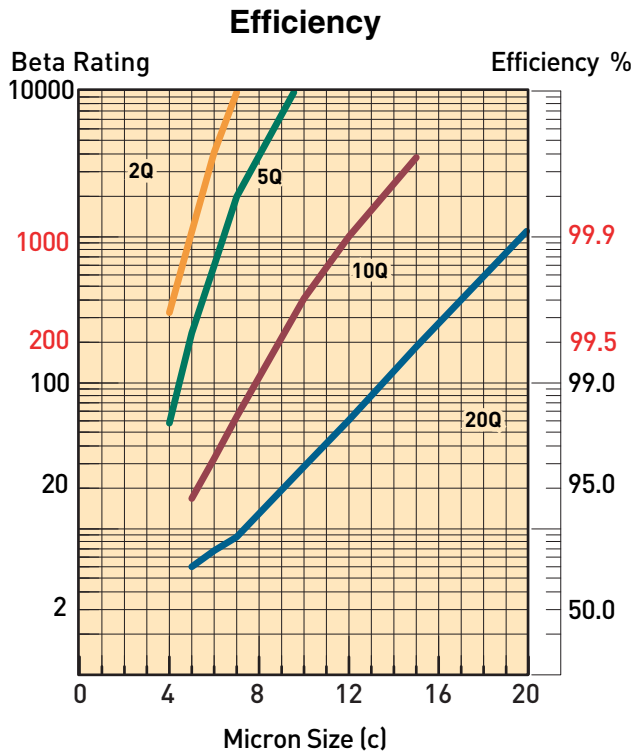

Results typical from Multi-pass tests run per test standard ISO 16889 @ 80 gpm to 100 psid terminal - 10 mg/L BUGL  
Refer to Appendix on pages 264-265 for relationship to test standard ISO 4572.

### Flow vs. Pressure Loss

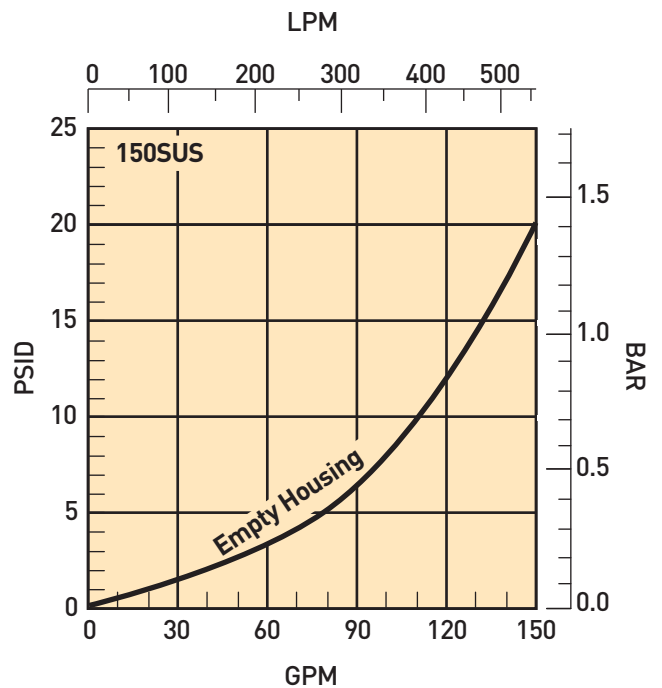
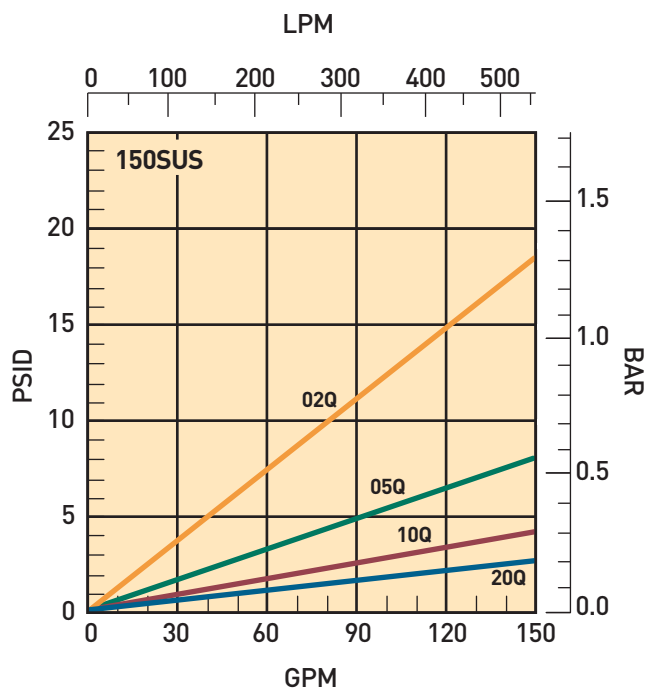

# 50P Series

## 50P-3 Element Performance

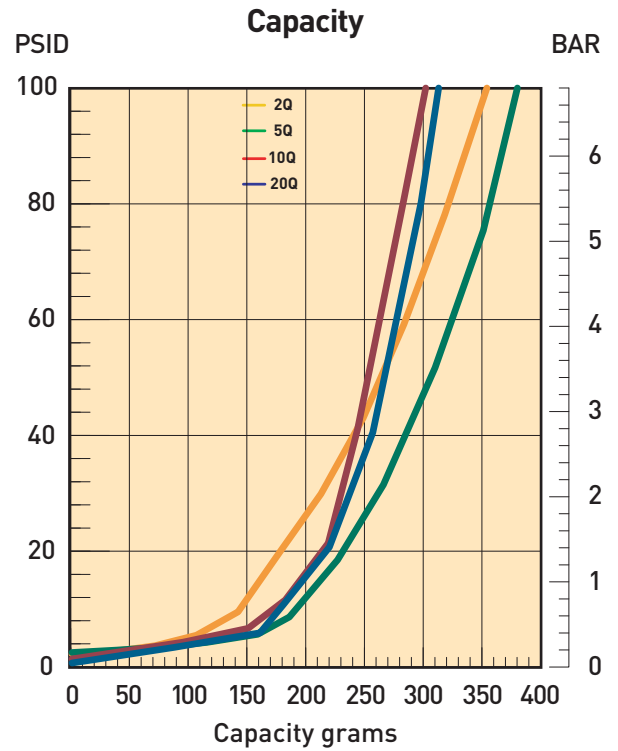
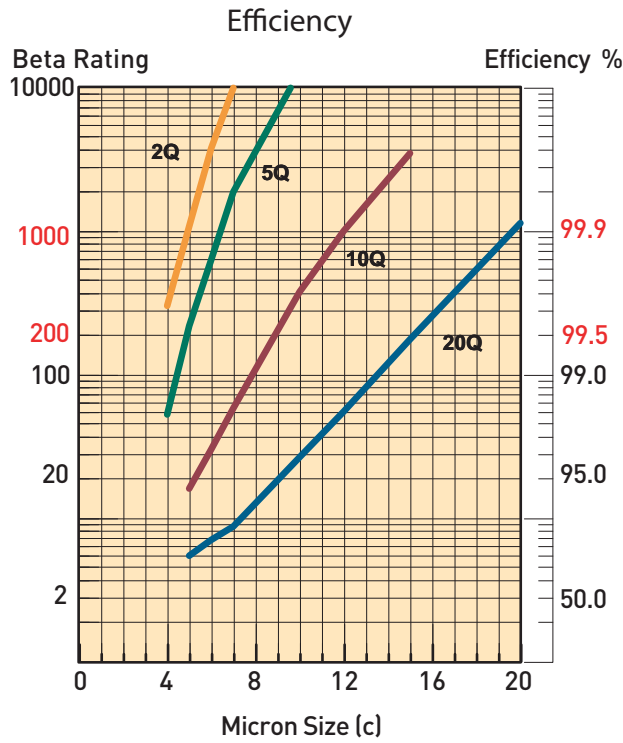

Results typical from Multi-pass tests run per test standard ISO 16889 @ 80 gpm to 100 psid terminal - 10 mg/L BUGL  
 Refer to Appendix on pages 264-265 for relationship to test standard ISO 4572.

### Flow vs. Pressure Loss

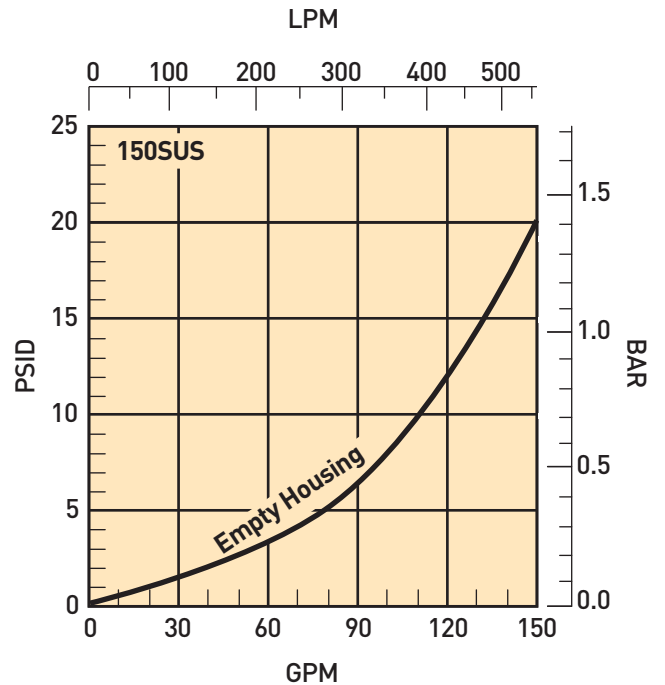
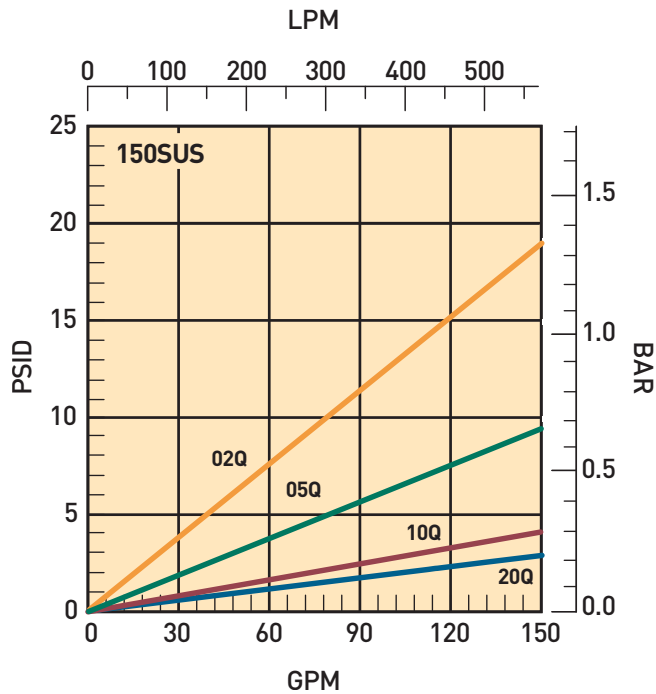

# 50P Series

## Specifications

### Pressure Ratings:

Maximum Allowable Operating Pressure (MAOP): 5000 psi (344.8 bar)  
 Rated Fatigue Pressure: 3500 psi (241.4 bar)  
 Design Safety Factor: 3:1

### Element Collapse Rating:

150 psid (10.2 bar) standard  
 2000 psid (138 bar) high collapse "H" option

### Operating Temperatures:

Buna: -40°F (-40°C) to 225°F (107°C)  
 Fluorocarbon: -15°F (-26°C) to 275°F (135°C)

### Filter Materials:

Head (base) and Cover: ductile iron  
 Bowl: seamless steel tube

### Indicators:

Visual 3 band (clean, change element, bypass)

Electrical: visual as above plus electrical switch with wire leads or connection as selected.

5A @ 240VAC

3A @ 28VDC

SPDT

### Color Coding:

White (normally closed)

Red (normally open)

Black (common)

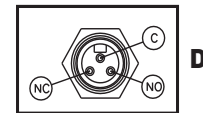

### Shipping Weights (approximate):

50P-1: 56 lb. (25.4 kg)

50P-2: 77 lb. (34.9 kg)

50P-3: 95 lbs. (43.0 kg)

50PR-1: 59 lb. (26.8 kg)

50PR-2: 80 lb. (36.3 kg)

Dimensions= mm/inches	50P-1	50PR-1	50P-2	50PR-2	50P-3
X	$\frac{387.1}{15.24}$	$\frac{404.6}{15.93}$	$\frac{622.8}{24.52}$	$\frac{640.3}{25.21}$	$\frac{850.4}{33.48}$
Z	$\frac{254.0}{10.00}$	$\frac{254.0}{10.00}$	$\frac{508.0}{20.00}$	$\frac{508.0}{20.00}$	$\frac{760.2}{30.00}$

Drawings are for reference only.  
 Contact factory for current version.

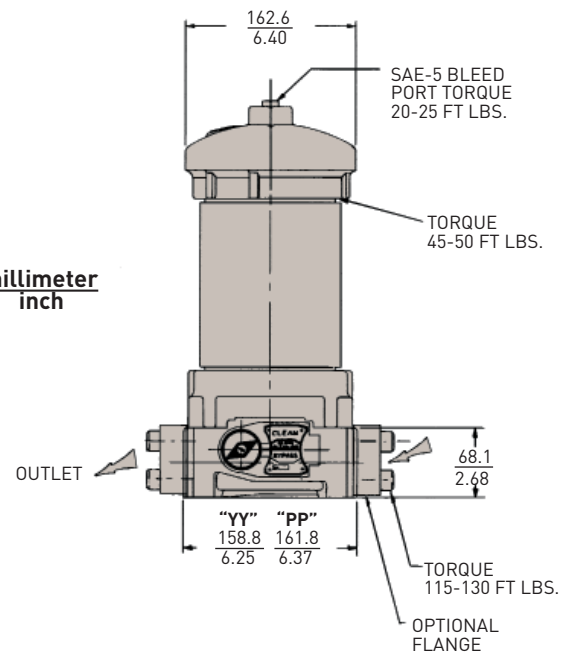
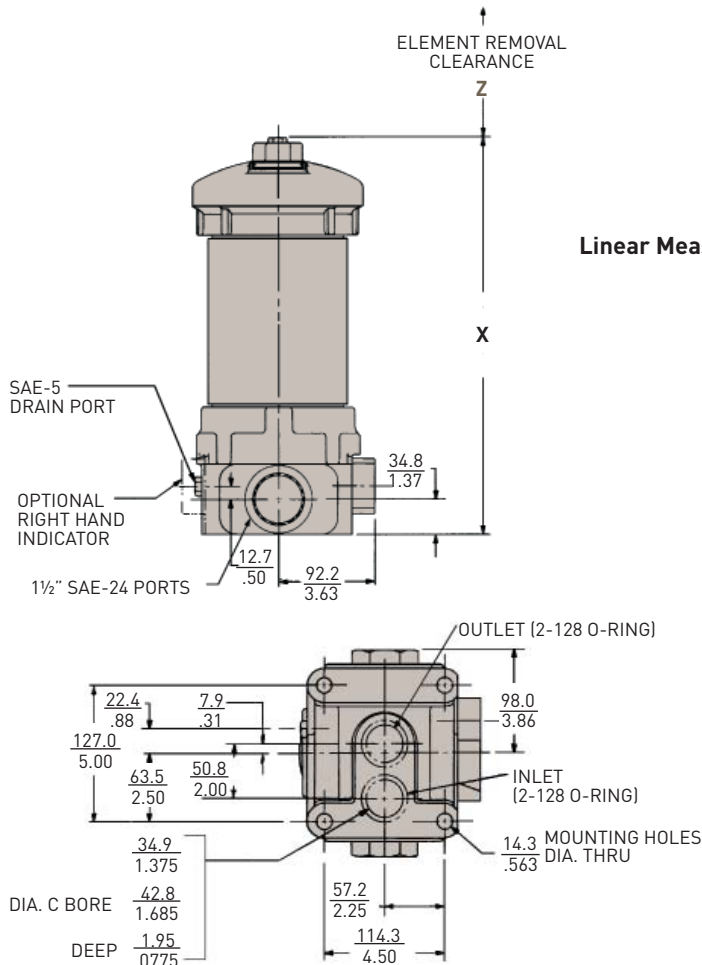





# 50P Series

## How to Order

BOX 1	BOX 2	BOX 3	BOX 4	BOX 5	BOX 6	BOX 7	BOX 8
F3	50P	1	10Q	DL	90	PP	1

BOX 1: Seals	
Symbol	Description
<b>None</b>	<b>Buna</b>
F3	Fluorocarbon
E8	EPR

BOX 2: Basic Assembly	
Symbol	Description
<b>50P</b>	<b>5000 PSI (MAOP)</b>
50PR*	Reverse flow hydrostatic version
*Note: Not available in triple length. Must select "1" or "2" in BOX 3	

BOX 3: Length	
Symbol	Description
<b>1</b>	<b>Single</b>
<b>2</b>	<b>Double</b>
<b>3</b>	<b>Triple</b>

BOX 4: Element Media	
Symbol	Description
20Q	Microglass III
10Q	Microglass III
05Q	Microglass III
02Q	Microglass III
Note: For high collapse 2000 psid rated elements, add "H" behind Q.	

BOX 5: Indicators	
Symbol	Description
<b>P</b>	<b>Port plugged</b>
<b>PL</b>	<b>Port plugged, left side</b>
M	Visual indicator
ML	Visual indicator, left side
E	Electrical indicator with wire leads and conduit connection
EL	Electrical indicator with wire leads and conduit connection, left side
D	Electrical indicator w/ ANSI/B.93.55M 3-pin Brad Harrison style connection
DL	Electrical indicator w/ ANSI/B.93.55M 3-pin Brad Harrison style connection, left side
Note: Left side is on viewer's left when looking into inlet port.	

BOX 6: Bypass and Indicator Setting	
Symbol	Pressure Setting
35	35 psid
50	50 psid
<b>90</b>	<b>90 psid</b>

BOX 7: Ports	
Symbol	Description
<b>PP</b>	<b>SAE-24 straight thread</b>
YY	SAE 1½" flange face (J518)
XX	1¾" manifold ports on bottom of head

BOX 8: Options	
Symbol	Description
<b>1</b>	<b>None</b>
<b>11</b>	<b>Blocked bypass</b>

### 50P/50PR Replacement Elements (Fluorocarbon)

Media	Standard Collapse			Media	High Collapse		
	Single	Double	Triple		Single	Double	Triple
20Q	931018Q	931020Q	933489Q	20QH	930438Q	931490Q	936449Q
10Q	932670Q	932679Q	933488Q	10QH	932676Q	932685Q	936448Q
05Q	932669Q	932678Q	933487Q	05QH	932675Q	932684Q	936447Q
02Q	932668Q	932677Q	933486Q	02QH	932674Q	932683Q	936446Q

Please note the bolded options reflect standard options with a reduced lead-time. Consult factory on all other lead-time options.