



# Snap-tite H, IH & PH Series

General Purpose Hydraulic and  
Pneumatic Quick Couplings

## Many Standard Configurations Suitable for Hydraulic and Pneumatic Applications:

Snap-tite H Series couplings have been proven by years of use on hydraulic and pneumatic applications.

H Series is best suited for general purpose fluid applications where either single or double shut-off valving is desired. A wide range of sizes, materials and end configurations are available.

PH version couplers and nipples are valved with a connect-under-pressure feature. These steel couplers and nipples allow connection with H Series valved couplers and nipples when there is residual pressure on the PH coupler/nipple side.

IH version couplers are steel with a cylindrical valve designed specifically for pneumatic use. When paired with an unvalved/plain H Series nipple, it functions as a durable single-shut-off connection.



## Contact Information:

Parker Hannifin Corporation  
**Quick Coupling Division**  
8145 Lewis Road  
Minneapolis, MN 55427

phone 763 544 7781  
fax 763 544 3418  
qcd\_sales@parker.com

[www.parker.com/quickcouplings](http://www.parker.com/quickcouplings)

## H Series Features:

- Sizes 1/4" -4"
- Available in steel, brass, aluminum and 316 stainless steel
- Seal material options available
- Optional sleeve lock helps to prevent accidental disconnection
- Double-shut-off version has low pressure drop
- Manually operated sleeve provides secure connection



ENGINEERING YOUR SUCCESS.

# Technical and Dimensional Information

**H Series couplings** are suitable for general purpose applications and a variety of media. They are very versatile in material, size and end configuration. Valve combinations include:

- Double shut-off poppet valves
- Single shut-off on the coupler or nipple side
- Straight through (unvalved/plain)

**PH version couplers** and nipples make it possible to overcome the high connection force caused by residual pressure. The poppet valves have an added pressure relief feature to allow connection under static pressures up to 3000 psi (210 bar). With a PH Series coupler or nipple installed on the pressurized line you can easily connect with a mating valved H Series. Available in steel, sizes 3/8", 1/2", 3/4" and 1".

**IH version couplers** have a cylindrical valve designed specifically for pneumatic systems and reciprocating, pulsating, rotary motion air tools. The IH valve provides 360° contact when connected with an unvalved/plain H Series nipple, enabling efficient operation and long life. Available in steel, sizes 1/4", 3/8", 1/2" and 3/4".

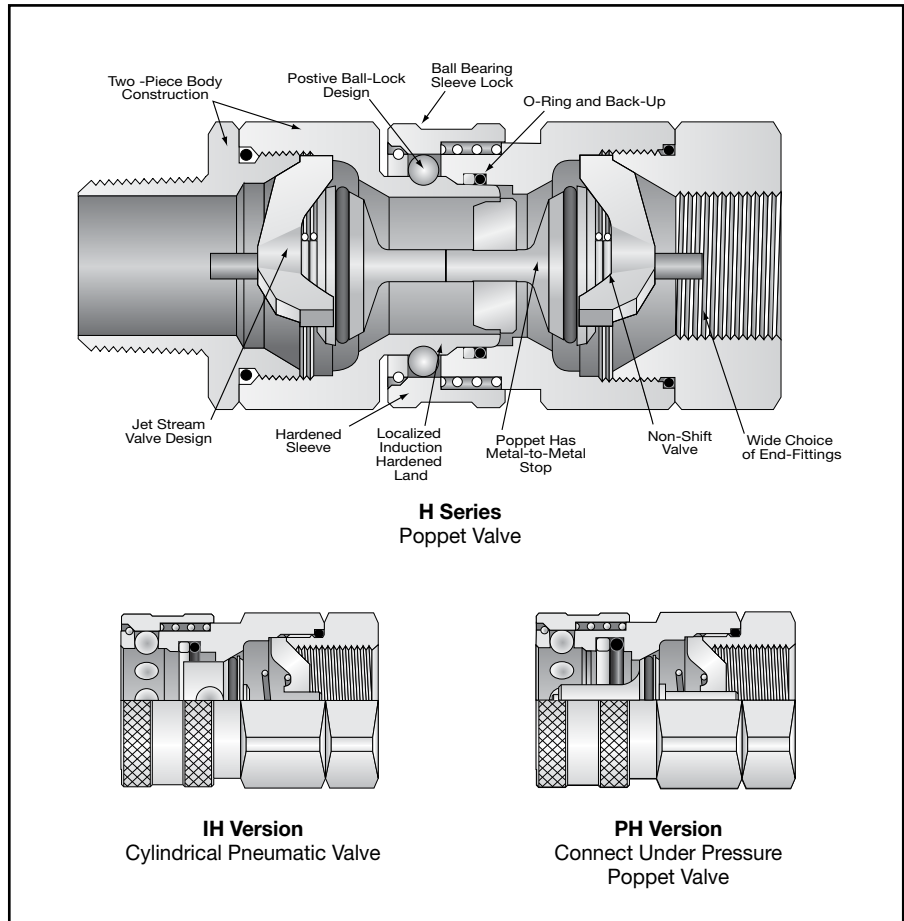

## Working Pressures

Size	Valved on both coupler and nipple (Double Shut-off) Valved on one half and Unvalved/Plain on other half (Single Shut-off)								Unvalved/Plain on both coupler and nipple (Straight Through)							
	Steel		Aluminum		Brass		Stainless Steel		Steel		Aluminum		Brass		Stainless Steel	
	psi	bar	psi	bar	psi	bar	psi	bar	psi	bar	psi	bar	psi	bar	psi	bar
1/4"	6500	448	2250	155	2250	155	5000	345	11000	759	4000	276	4000	276	10000	690
3/8"	4500	310	2250	155	2250	155	4000	276	11000	759	4000	276	4000	276	8000	552
1/2"	4000	276	1750	121	2000	138	3750	259	11000	759	4000	276	4000	276	8000	552
3/4"	3500	241	1750	121	2000	138	2000	138	9000	621	3500	241	3500	241	7000	483
1"	2000	138	1500	103	1750	121	2000	138	6000	414	3000	207	3000	207	4000	276
1-1/4"	1750	121	375	26	350	24	1500	103	5000	345	1000	69	1000	69	3000	207
1-1/2"	1500	103	375	26	350	24	1500	103	5000	345	1000	69	1000	69	3000	207
2"	1500	103	300	21	400	28	500	34	4000	276	750	52	750	52	1000	69
2-1/2"	1000	69	300	21	400	28	400	28	1000	69	300	21	400	28	400	28
3"	750	52	200	14	200	14	400	28	750	52	200	14	200	14	400	28
4"	500	34	150	10	150	10	300	21	500	34	150	10	150	10	300	21

**NOTE:** Pressure ratings were established under static pressure conditions. Therefore, pressure ratings for any given flow, pressure surge and/or vibration may vary from these ratings. Burst pressures listed were taken at the point at which failure rendered the quick disconnect inoperative. (Proof pressure equals 1-1/2 times the working pressure; burst pressure equals 2 times working pressure.)

Flow Charts

### H Series

Valved and Valved (Double Shut-off)  
FLOW RATE (LPM)

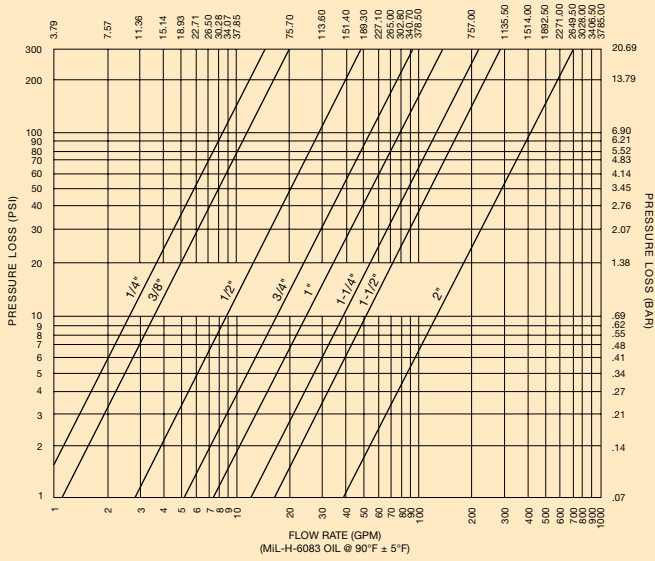

Valved and Plain (Single Shut-off)  
FLOW RATE (LPM)

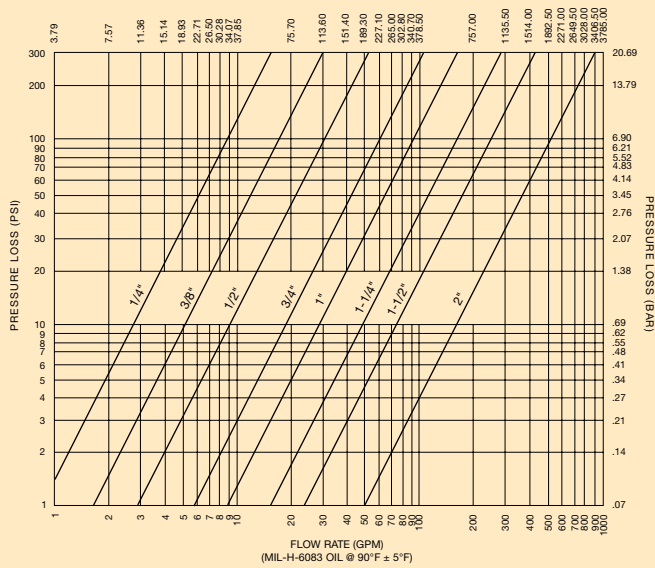

### IH Series

CFM FREE AIR AT 17.7 PSIA, 70F

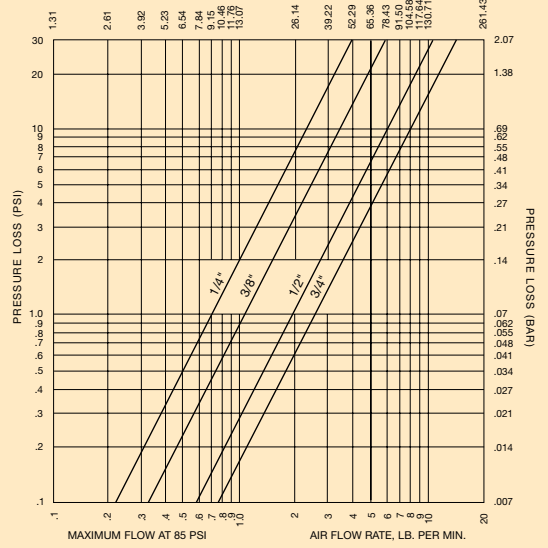

### PH Series

Valved and Valved (Double Shut-off)  
FLOW RATE (LPM)

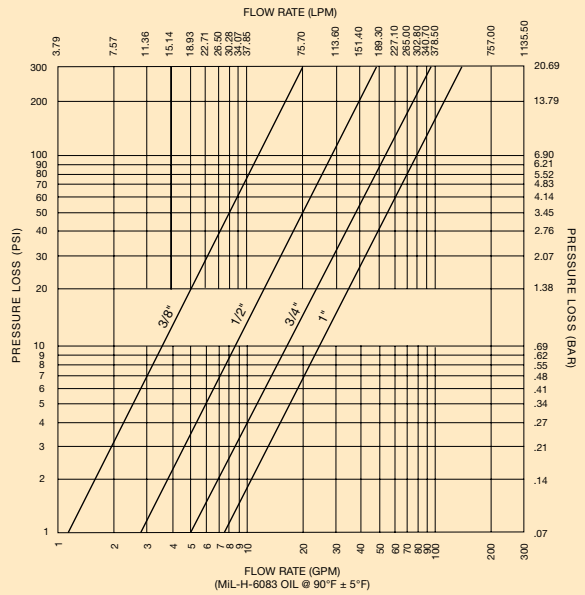

**Valved Coupler and Nipple Dimensions (without end fitting)**

Size	1/4"	3/8"	1/2"	3/4"	1"	1-1/4"	1-1/2"	2"	2-1/2"	3"	4"	
<b>A</b>	in	1.34	1.50	1.62	1.92	2.07	2.28	2.57	3.14	3.63	3.88	4.58
	mm	34.04	38.10	41.15	48.77	52.58	57.91	65.28	79.76	92.20	98.55	116.33
<b>B</b>	in	1.00	1.19	1.39	1.63	2.00	2.19	2.75	3.50	4.50	5.45	6.75
	mm	25.40	30.23	35.31	41.40	50.80	55.63	69.85	88.90	114.30	138.13	171.45
<b>C</b>	in	1.28	1.44	1.51	1.79	1.95	2.15	2.41	2.94	3.42	3.79	4.47
	mm	32.51	36.58	38.35	45.47	49.53	54.61	61.21	74.68	86.87	96.27	113.54
<b>D<sup>2</sup></b>	in	.88	1.00	1.19	1.50	1.88	2.00	2.75	3.75	4.50	4.75	6.75
	mm	22.35	25.40	30.23	38.10	47.75	50.80	69.85	95.25	114.30	120.65	171.45
<b>H</b>	in	.58	.71	.72	.88	.91	.90	1.06	1.32	1.41	1.56	1.93
	mm	14.73	18.03	18.29	22.35	23.11	22.86	26.92	33.53	35.81	39.62	49.02

**Valved Coupler and Nipple End Fitting Dimensions**

Size	1/4"	3/8"	1/2"	3/4"	1"	1-1/4"	1-1/2"	2"	2-1/2"	3"	4"		
 Male Tapered Pipe	<b>F</b>	in	.75	.69	.95	.96	1.14	1.31	1.44	1.40	1.83	1.88	2.88
		mm	19.05	17.53	24.13	24.38	28.96	33.27	36.58	35.56	46.48	47.75	73.15
	<b>G<sup>1</sup></b>	in	.88	1.00	1.19	1.50	1.88	2.00	2.50	3.38	4.00	4.75	6.00
		mm	22.35	25.40	30.23	38.10	47.75	50.80	63.50	88.90	101.60	120.65	152.40
 EM Male SAE Flared and MS33656	<b>F</b>	in	.74	.74	.84	1.13	1.16	1.27	1.46	1.71			
		mm	18.80	18.80	21.34	28.70	29.46	32.26	37.08	43.43			
	<b>G<sup>1</sup></b>	in	.88	1.00	1.19	1.50	1.88	2.00	2.50	3.38			
		mm	22.35	33.27	30.23	38.10	47.75	50.80	63.50	88.90			
 MS33657	<b>F</b>	in	1.23	1.31	1.47	1.84	1.84	1.95					
		mm	31.31	33.27	37.34	46.74	46.74	49.53					
	<b>G<sup>1</sup></b>	in	.88	1.00	1.19	1.50	1.88	2.00					
		mm	22.35	25.40	30.23	38.10	47.75	50.80					
 Female Tapered Pipe	<b>F</b>	in	.31	.40	.47	.50	.60	1.26	.70	.78	.90	.88	1.13
		mm	7.87	10.16	11.94	12.70	15.24	32.00	17.78	19.81	22.86	22.35	28.70
	<b>G<sup>1</sup></b>	in	.88	1.00	1.19	1.50	1.88	2.00	2.50	3.50	4.00	4.75	6.00
		mm	22.35	25.40	30.23	38.10	47.75	50.80	63.50	88.90	101.60	120.65	152.40
 EF Female Straight and MS33649	<b>F</b>	in	.46	.70	.57	1.00	.87	1.11	.85	1.01			
		mm	11.68	17.78	14.48	25.40	22.10	28.19	21.59	25.65			
	<b>G<sup>1</sup></b>	in	.88	1.00	1.19	1.50	1.88	2.00	2.50	3.50			
		mm	22.35	25.40	30.23	38.10	47.75	50.80	63.50	88.90			
 EB Male SAE Bulk-Head	<b>F</b>	in	1.39	1.56	1.67	2.03	1.84	2.14					
		mm	35.30	39.62	42.42	51.56	46.74	54.36					
	<b>G<sup>1</sup></b>	in	.88	1.00	1.19	1.50	1.88	2.00					
		mm	22.35	25.40	30.23	38.10	47.75	50.80					
 Female RP <sup>4</sup> British Parallel	<b>F</b>	in	.39	.40	.53	.56	.60	1.26	.70	.78	.90	.88	1.13
		mm	9.91	10.16	13.46	14.22	15.24	32.00	17.78	19.81	22.86	22.35	28.70
	<b>G<sup>1</sup></b>	in	.88	1.00	1.19	1.50	1.88	2.00	2.50	3.50	4.00	4.75	6.00
		mm	22.35	25.40	30.23	38.10	47.75	50.80	63.50	88.90	101.60	120.65	152.40

Unvalved/Plain Coupler and Nipple End Configurations

		Female Pipe Thread				Female RP British Parallel Thread				Male Pipe Thread			
Size		1/4"	3/8"	1/2"	3/4"	1"	1-1/4"	1-1/2"	2"	2-1/2"	3"	4"	
A	in	1.34	1.50	1.62	1.91	2.07	2.28	2.57	2.48	3.11	3.35	3.88	
	mm	34.04	38.10	41.15	48.51	52.58	57.91	65.28	62.99	78.99	85.09	98.55	
B	in	1.00	1.19	1.39	1.63	2.00	2.19	2.75	3.50	4.50	5.45	6.75	
	mm	25.40	30.23	35.31	41.40	50.80	55.63	69.85	88.90	114.30	138.43	171.45	
C	in	1.32	1.52	1.72	1.92	2.10	2.22	2.44	2.60	2.95	3.40	3.73	
	mm	33.53	38.61	43.69	48.77	53.34	56.39	61.98	66.04	74.93	86.36	94.74	
D <sup>1</sup>	in	.88	1.00	1.19	1.50	1.88	2.00	2.50	3.25	3.75	4.75	5.50	
	mm	22.35	25.40	30.23	38.10	47.75	50.80	63.50	82.55	95.25	120.65	139.70	
E <sup>1,2</sup>	in	.63	.81	1.00	1.19	1.50	1.88	2.13	2.75	3.25	4.00	5.00	
	mm	16.00	20.57	25.40	30.23	38.10	47.75	54.10	69.85	82.55	101.60	127.00	
H	in	.58	.71	.72	.88	.91	.90	1.06	1.32	1.41	1.56	1.93	
	mm	14.73	18.03	18.29	22.35	23.11	22.86	26.92	33.53	35.81	39.62	49.02	
K	in	.78	.98	1.01	1.14	1.16	1.17	1.34	2.03	2.08	2.59	2.58	
	mm	19.81	24.89	25.65	28.96	29.46	29.72	34.04	51.56	52.83	65.79	65.53	
J <sup>1</sup>	in	.56	.69	.88	1.06	1.38	1.88	2.13	2.50	3.25	4.00	5.00	
	mm	14.22	17.53	22.35	26.92	35.05	47.75	54.10	63.50	82.55	101.60	127.00	
L	in	1.27	1.44	1.72	1.86	2.13	2.22	2.44	2.60	2.95	3.40	3.73	
	mm	32.26	36.58	43.69	47.24	54.10	56.39	61.98	66.04	74.93	86.36	94.74	

**NOTES:** <sup>1</sup> Dimensions taken across the hex flats. Round stock with two milled flats may be substituted for hex stock. Dimensions across flats same as dimensions across hex flats. Max O.D. of round stock will not exceed the dimensions across the points of the hex stock. Valve coupler and nipple bodies may be supplied from round bar stock without wrench flats.

<sup>2</sup> Notch on hex indicates RP British parallel threads.

Accessories

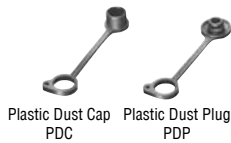

Plastic Dust Cap PDC  
Plastic Dust Plug PDP

Dust caps, dust plugs and pressure caps protect disconnected couplers and nipples from damage, dirt and other contaminants. Dust caps and dust plugs are available in plastic and clear anodized aluminum.

**Plastic Cap and Plug**

Designed with a loop to fit over fitting or affixing to equipment with a sheet metal screw. Available in sizes 1/4" thru 1".

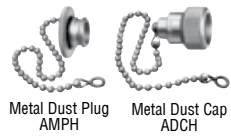

Metal Dust Plug AMPH  
Metal Dust Cap ADCH

**Aluminum Dust Caps and Plugs**

Aluminum dust caps and plugs are available in sizes 1/4" thru 3". The 1/4" thru 3/4" sizes come with 10" chrome plated brass bead chain. The 1" and above come with steel zinc plated sash chain.

**Pressure Caps**

Pressure-tight pressure caps for nipples are standard in steel, Trivalent plated. Other materials such as brass, aluminum and stainless steel available on special order. Sizes available 1/4" thru 3". Sizes 1/4" thru 3/4" come with 10" length of corrosion resistant steel cable. Sizes 1" thru 3" come with 12" of cable-all with adjustable loop at end of cable. Consult QCD for special lengths.



Metal Pressure Cap MCH

Sizes	Plastic Cap	Plastic Plug	Aluminum Plug	Aluminum Cap	Pressure Cap
1/4"	PDC-4	PDP-4	AMPH-4	ADCH-4	MCH-4
3/8"	PDC-6	PDP-6	AMPH-6	ADCH-6	MCH-6
1/2"	PDC-8	PDP-8	AMPH-8	ADCH-8	MCH-8
3/4"	PDC-12	PDP-12	AMPH-12	ADCH-12	MCH-12
1"	PDC-16	PDP-16	AMPH-16	ADCH-16	MCH-16
1-1/4"			AMPH-20	ADCH-20	MCH-20
1-1/2"			AMPH-24	ADCH-24	MCH-24
2"			AMPH-32	ADCH-32	MCH-32
2-1/2"			AMPH-40	ADCH-40	MCH-40
3"			AMPH-48	ADCH-48	MCH-48

Ordering Information

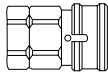
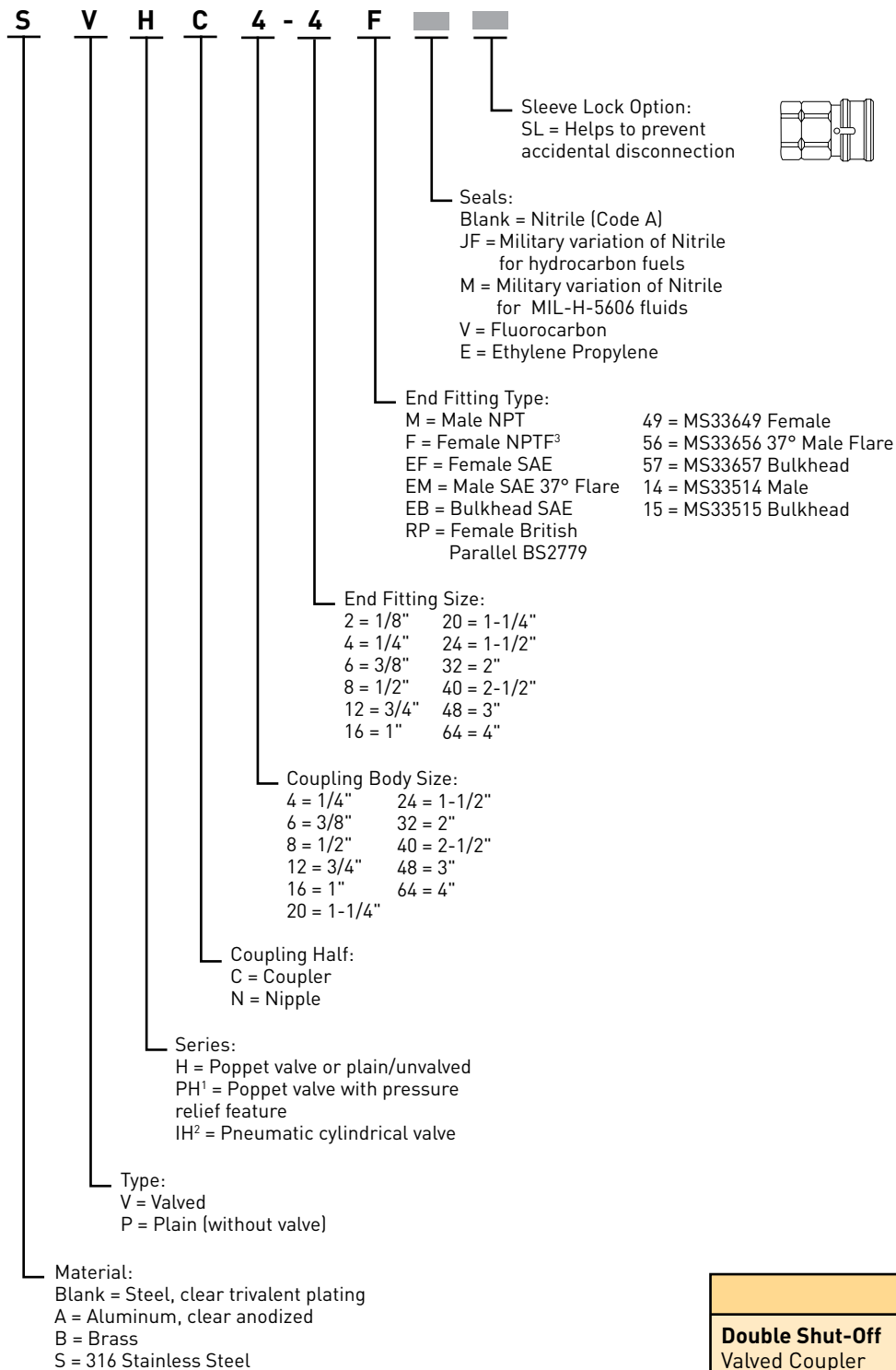

<sup>1</sup>PH Valve option recommended on one side, not both. Available in steel only.  
<sup>2</sup>IH available in steel only.  
<sup>3</sup>For sizes up to 1" NPTF threads in steel.  
 For sizes up to 1" NPSF threads in stainless steel.  
 For sizes over 1" NPT threads.

**Note:** Not all configurations are standard product offering. Contact QCD for price and delivery.

	H	PH	IH
<b>Double Shut-Off</b> Valved Coupler Valved Nipple	•	•	
<b>Single Shut-Off</b> Valved Coupler Unvalved/Plain Nipple	•		•
<b>Straight Through</b> Unvalved/Plain Coupler Unvalved/Plain Nipple	•		

**Replacement Parts**

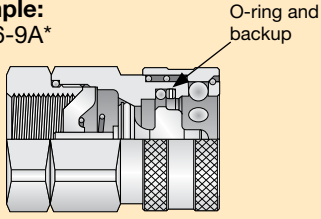
Valve Kits	Valve Seals	Coupler Interface Seals
<p>Includes valve, valve spring and stop. Valve seal is included in sizes 3/8" thru 1" in steel, brass and aluminum only.</p> <p>Part Number – Use the base part number followed by SPK.</p> <p><b>Example:</b> VHC4-SPK VIHC6-SPK</p>	<p>1/4" valve seal is staked in the coupler and nipple bodies in all materials and is not considered field repairable. 3/8" and above are available for repair.</p> <p>Part Number – "H (size)-55 (seal material)"</p> <p><b>Example:</b> H6-55A* H8-55A*</p>	<p>Includes O-ring and back-up ring. Part Number "H (size)-56-9 (seal material)".</p> <p><b>Example:</b> H6-56-9A*</p>  <p>Previous design was U-Packer. Consult QCD for availability.</p>

\*"A" required for Nitrile Seal Kits. Refer to the part number code for other seal options.

**Standard Configurations for General Purpose Hydraulic and Pneumatic Applications**

	H Series Hydraulic Coupler/Nipple	PH Series Hydraulic Coupler/Nipple	IH Series Pneumatic Coupler
<b>Valve Styles:</b>	<ul style="list-style-type: none"> <li>• Poppet Valve</li> <li>• Unvalved/Plain</li> </ul>	<ul style="list-style-type: none"> <li>• Connect-Under-Pressure Poppet Valve</li> </ul>	<ul style="list-style-type: none"> <li>• Cylindrical Valve</li> </ul>
<b>Connection Types:</b>	<ul style="list-style-type: none"> <li>• Double Shut-off</li> <li>• Single Shut-off</li> <li>• Straight Through/Unvalved</li> </ul>	<ul style="list-style-type: none"> <li>• Double Shut-off (connects with valved H Series Coupler or Nipple)</li> </ul>	<ul style="list-style-type: none"> <li>• Single Shut-off (connects with unvalved/plain H Series Nipple)</li> </ul>
<b>Body Sizes:</b>	1/4" - 4"	3/8" - 1"	1/4" - 3/4"
<b>Materials:</b>	<ul style="list-style-type: none"> <li>• Steel</li> <li>• 316 Stainless Steel</li> <li>• Aluminum</li> <li>• Brass</li> </ul>	<ul style="list-style-type: none"> <li>• Steel</li> </ul>	<ul style="list-style-type: none"> <li>• Steel</li> </ul>

