

General Description

Series PCK pressure compensated flow control valves are designed to regulate flow at a selected rate, within 5%, regardless of fluctuations in inlet and outlet pressure.

Operation

Series PCK valves are factory-set for a specified flow. The flow can be changed with a different "PCK" Orifice Plug Kit (sold separately).

Features

- Available with reverse flow check.
- Flow precision within $\pm 5\%$ of full flow.

Specifications

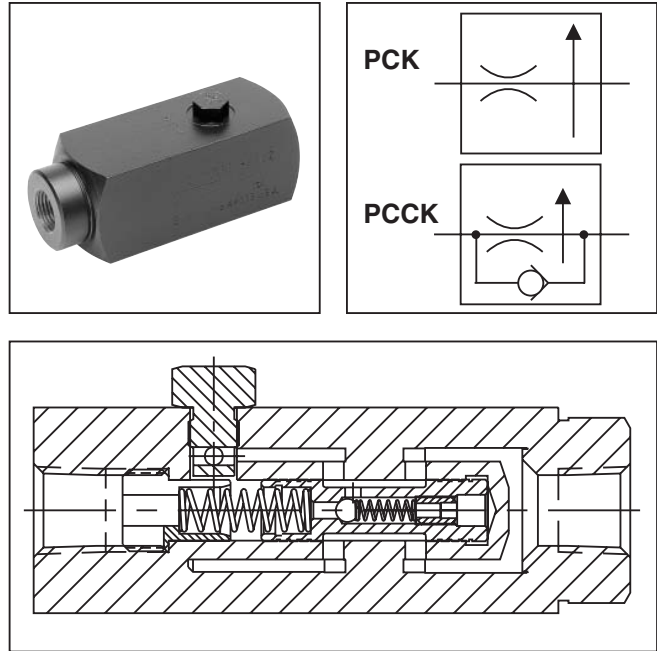

	PC*K400S PC*K620S	PC*K600S PC*K820S	PC*K800S PC*K1020S	PC*K1200S PC*K1220S
Maximum Operating Pressure	207 Bar (3000 PSI)			
Minimum Pressure to Compensate	6.9 Bar (100 PSI)	6.9 Bar (100 PSI)	6.9 Bar (100 PSI)	10.4 Bar (150 PSI)
Temperature Range of Seal Compound	-40°C to +121°C (-40°F to +250°F) Nitrile (standard) -26°C to +205°C (-15°F to +400°F) Fluorocarbon			
Mounting	In-line			
Maximum Flow	11 LPM (3 GPM)	23 LPM (6 GPM)	57 LPM (15 GPM)	95 LPM (25 GPM)
Minimum Flow	1 LPM (0.3 GPM)	2 LPM (0.6 GPM)	6 LPM (1.5 GPM)	10 LPM (2.5 GPM)
Reverse Flow, Maximum thru Check	19 LPM (5 GPM)	30 LPM (8 GPM)	76 LPM (20 GPM)	132 LPM (35 GPM)
Pressure Drop, ΔP at Maximum Reverse Flow thru Check	3 Bar (40 PSI)	3 Bar (40 PSI)	PC*K800S: 8 Bar (116 PSI) PC*K1020S: 3 Bar (40 PSI)	PC*K1200S: 8 Bar (116 PSI) PC*K1220S: 3 Bar (40 PSI)
Port Size (in.)	PC*K400S: 1/4 NPTF PC*K620S: 9/16-18 UNF (SAE 6)	PC*K600S: 3/8 NPTF PC*K820S: 3/4-16 UNF (SAE 8)	PC*K800S: 1/2 NPTF PC*K1020S: 7/8-14 UNF (SAE 10)	PC*K1200S: 3/4 NPTF PC*K1220S: 1-1/16-12 UN (SAE 12)

* For optional reverse-flow check, insert "C" in model number at asterisk (*).

<input type="checkbox"/> Options	<input checked="" type="checkbox"/> PC Pressure Compensated Flow Control	<input type="checkbox"/> Reverse Check	<input checked="" type="checkbox"/> K Fixed Flow	<input type="checkbox"/> Port Size	<input checked="" type="checkbox"/> S Material	<input type="checkbox"/> Flow *	<input type="checkbox"/> Seal Compound	<input type="checkbox"/> Design Series NOTE: Not required when ordering.
-------------------------------------	--	--	---	--	--	------------------------------------	--	---

Code	Description
Omit	NPTF/SAE
★ 9	BSPP

Code	Description
Omit	Without
C	Check

Code	Description
S	Steel

Code	Description
Omit	Nitrile (Standard)
V	Fluorocarbon

★ Code 9 can be used with sizes 400, 600, 800 and 1200

Code	Size
400	1/4"
600	3/8"
620	#6 SAE
800	1/2"
820	#8 SAE
1020	#10 SAE
1200	3/4"
1220	#12 SAE

Available Flow Settings GPM (LPM)			
PCK 400/620 GPM (LPM)	PCK 600/820 GPM (LPM)	PCK 800/1020 GPM (LPM)	PCK 1200/1220 GPM (LPM)
0.25 (0.9)	0.50 (1.9)	2.00 (7.57)	4.00 (15.14)
0.50 (1.9)	1.00 (3.8)	3.00 (11.36)	6.00 (22.71)
0.75 (2.8)	1.50 (5.7)	4.00 (15.14)	8.00 (30.28)
1.00 (3.8)	2.00 (7.6)	5.00 (18.93)	10.00 (37.85)
1.25 (4.7)	2.50 (9.5)	6.00 (22.71)	12.00 (45.42)
1.50 (5.7)	3.00 (11.4)	7.00 (26.50)	14.00 (52.99)
1.75 (6.6)	3.50 (13.2)	8.00 (30.28)	16.00 (60.56)
2.00 (7.6)	4.00 (15.1)	9.00 (34.07)	18.00 (68.13)
2.25 (8.5)	4.50 (17.0)	10.00 (37.85)	20.00 (75.70)
2.50 (9.5)	5.00 (18.9)	11.00 (41.64)	22.00 (83.27)
2.75 (10.4)	5.50 (20.8)	12.00 (45.42)	24.00 (90.84)
3.00 (11.4)	6.00 (22.7)	13.00 (49.21)	
		14.00 (52.99)	
		15.00 (56.78)	

Note: Settings are based on using 100 SSU at +49°C (+120°F).

* To order this valve you must indicate appropriate GPM value from table. Example: 9PCCK600S-3.50-V

“PK” Orifice Plug Kits

<input checked="" type="checkbox"/> PK Plug Kit	<input type="checkbox"/> Valve Size	<input type="checkbox"/> Flow*	<input type="checkbox"/> Seals	<input type="checkbox"/> Design Series NOTE: Not required when ordering.
---	--	-----------------------------------	-----------------------------------	---

Code	NPTF	SAE
4	400	620
6	600	820
8	800	1020
12	1200	1220

Code	Description
N	Nitrile (Standard)
V	Fluorocarbon

Available Flow Settings GPM (LPM)			
PCK 400/620 GPM (LPM)	PCK 600/820 GPM (LPM)	PCK 800/1020 GPM (LPM)	PCK 1200/1220 GPM (LPM)
0.25 (0.9)	0.50 (1.9)	2.00 (7.57)	4.00 (15.14)
0.50 (1.9)	1.00 (3.8)	3.00 (11.36)	6.00 (22.71)
0.75 (2.8)	1.50 (5.7)	4.00 (15.14)	8.00 (30.28)
1.00 (3.8)	2.00 (7.6)	5.00 (18.93)	10.00 (37.85)
1.25 (4.7)	2.50 (9.5)	6.00 (22.71)	12.00 (45.42)
1.50 (5.7)	3.00 (11.4)	7.00 (26.50)	14.00 (52.99)
1.75 (6.6)	3.50 (13.2)	8.00 (30.28)	16.00 (60.56)
2.00 (7.6)	4.00 (15.1)	9.00 (34.07)	18.00 (68.13)
2.25 (8.5)	4.50 (17.0)	10.00 (37.85)	20.00 (75.70)
2.50 (9.5)	5.00 (18.9)	11.00 (41.64)	22.00 (83.27)
2.75 (10.4)	5.50 (20.8)	12.00 (45.42)	24.00 (90.84)
3.00 (11.4)	6.00 (22.7)	13.00 (49.21)	
		14.00 (52.99)	
		15.00 (56.78)	

Model Number	Weight kg (lbs.)
PK4-*N	0.5 (0.1)
PK6-*N	0.5 (0.1)
PK8-*N	0.5 (0.1)
PK12-*N	0.5 (0.1)

Note: Settings are based on using 100 SSU at +120°F (+49°C).

* To order this plug kit you must indicate appropriate GPM value from table. Example: PK6-3.50-N

Performance Curves

PC*K Series
Controlled Flow vs. Pressure Drop
 at Maximum Flow Setting
 Typical for All Sizes

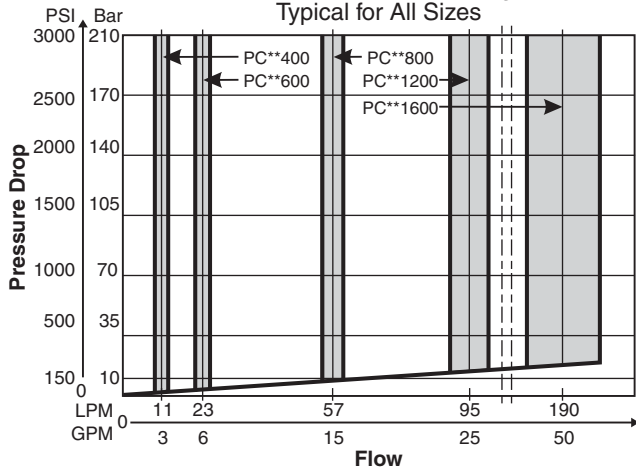

Dimensions

Inch equivalents for millimeter dimensions are shown in (**)

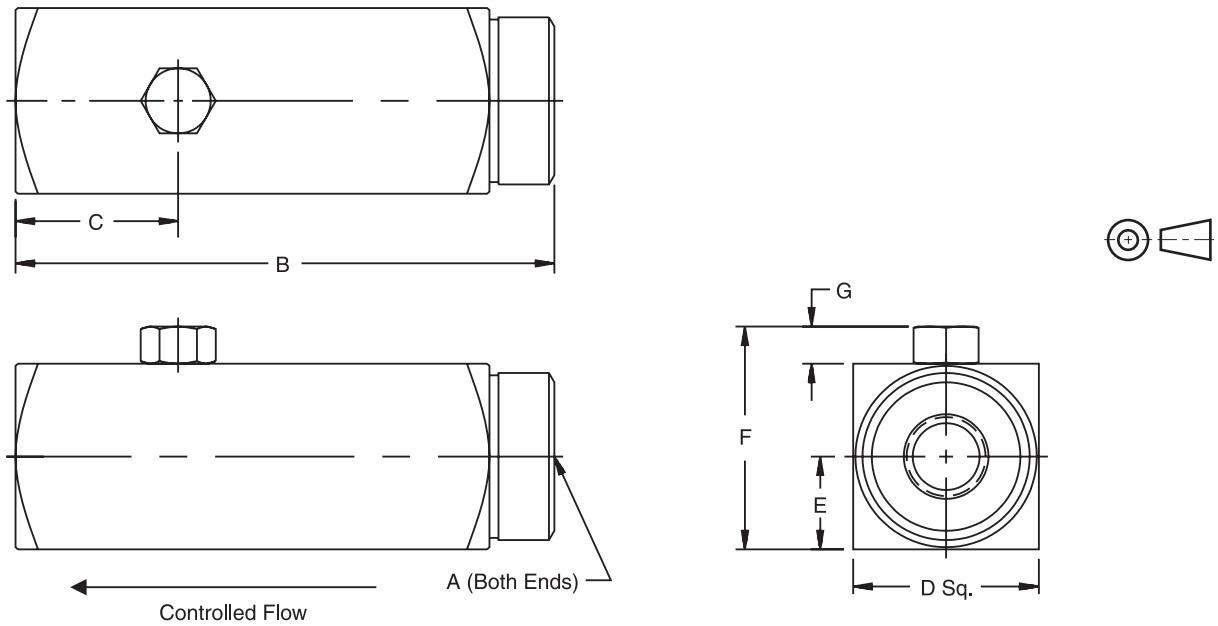

Model Number	Weight kg (lbs.)	A	B	C	D	E	F	G
PC*K400/620	0.03 (0.7)	1/4-18 NPTF/9/16-18 UNF	92.2 (3.63)	27.7 (1.09)	31.8 (1.25)	17.5 (0.69)	38.1 (1.50)	6.4 (0.25)
PC*K600	1.00 (2.1)	3/8-18 NPTF	105.7 (4.16)	30.2 (1.19)	38.1 (1.50)	19.1 (0.75)	44.5 (1.75)	6.4 (0.25)
PC*K 820	1.00 (2.1)	3/4-16 UNF	112.5 (4.43)	37.3 (1.47)	38.1 (1.50)	19.1 (0.75)	44.5 (1.75)	6.4 (0.25)
PC*K800/1020	1.50 (3.3)	1/2-14 NPTF/7/8-14 UNF	125.5 (4.94)	36.6 (1.44)	44.5 (1.75)	22.4 (0.88)	50.8 (2.00)	6.4 (0.25)
PC*K1200/1220	1.50 (3.3)	3/4-14 NPTF/1 1/16-12 UNF	149.4 (5.88)	27.7 (1.09)	57.2 (2.25)	28.7 (1.13)	63.5 (2.50)	6.4 (0.25)

3300-colorflow.indd, ddp

