

Series “BA” Bladder Accumulators

Maintenance Instructions

- 10 cu. in. through 15 Gallons
- 250 bar & 350 bar Standard
- 3,000 & 5,000 PSI Standard
- Bottom & Conventional
Top Repairable



Installation

All accumulators shipped from the factory will be precharged to a nominal pressure in order to seat the poppet valve on the hydraulic port. In this case the precharge will not be listed on the label. However, in some cases they will be shipped with a nitrogen charge, the value of which will be marked on the label/nameplate.

Keep the hydraulic port covered to keep out foreign material until ready to make the hydraulic connections.

The accumulator should be mounted within 25° of vertical with the hydraulic port on the bottom. It should also be rigidly mounted using appropriate mounting hardware, which is shown in the Accumulator Accessories section of this catalog. The hydraulic circuit, which contains a connection to the accumulator, should be designed so that it automatically discharges all hydraulic fluid from the accumulator when the equipment is turned off.

Installation

Most accumulators shipped from the factory carry a nominal pre-charge. However, in some cases they will be shipped with some amount of nitrogen charge, the value of which will be stamped on the nameplate.

Keep the hydraulic port covered to keep out foreign material until ready to make the hydraulic connections.

The accumulator should be mounted within 25° of vertical with the hydraulic port on the bottom. It should also be rigidly mounted using appropriate mounting hardware, which is shown in the Accumulator Accessories section of this catalog. The hydraulic circuit, which contains a connection to the accumulator, should be designed so that it automatically discharges all hydraulic fluid from the accumulator when the equipment is turned off.

Example 1

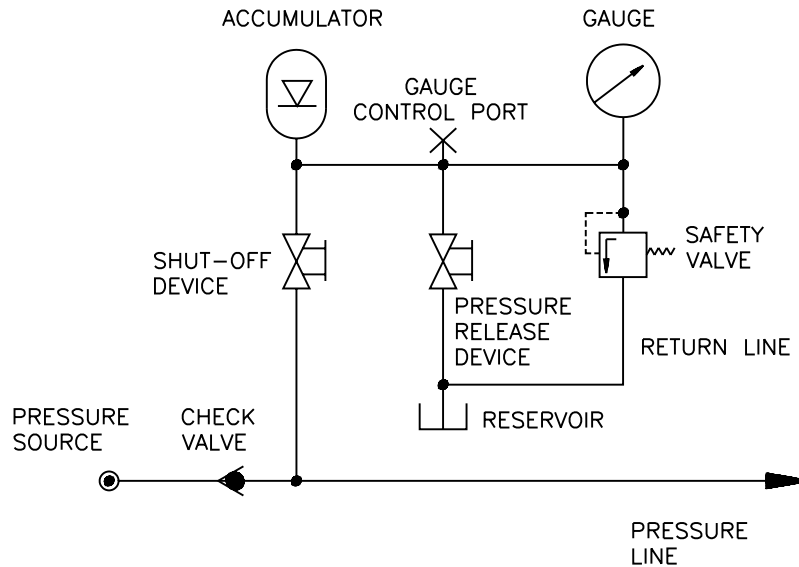

Basic safety equipment for a single accumulator with permanently connected safety valve and gauge, gauge control port, manually operated shut-off device, pressure release device and return line to the reservoir. Safety components may be connected by lines and/or installed in a safety block. The accumulator must always be protected with sufficient discharge capacity. If a check valve prevents flow back to the pressure source (pump), a shut-off device is not required for safety reasons but may be appropriate for service and maintenance.

Example 2

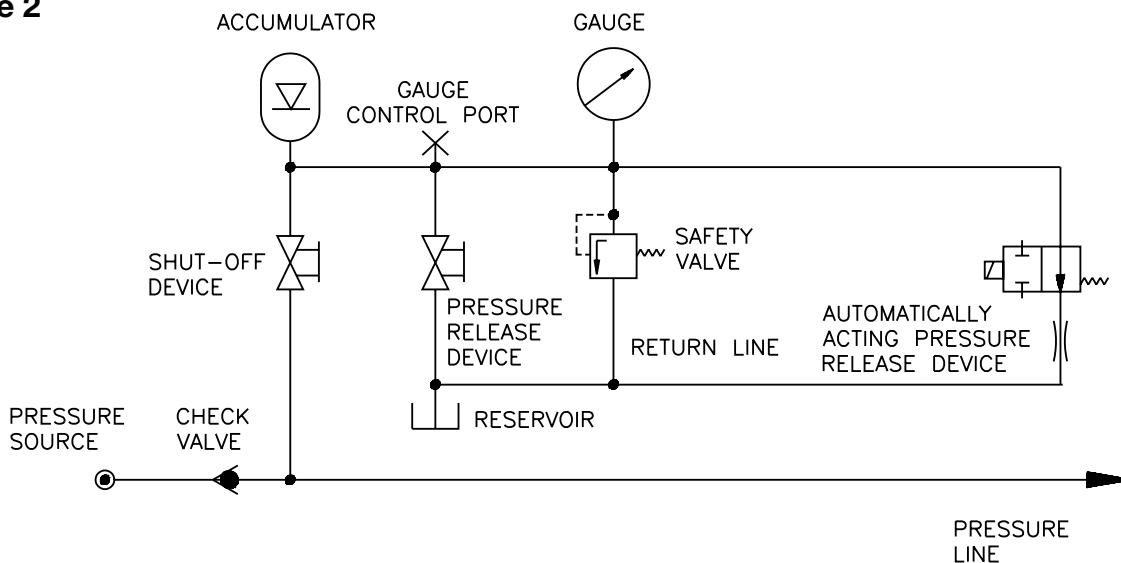

Configuration with additional pressure release device which opens automatically in the case of circuit break down.

Example 3

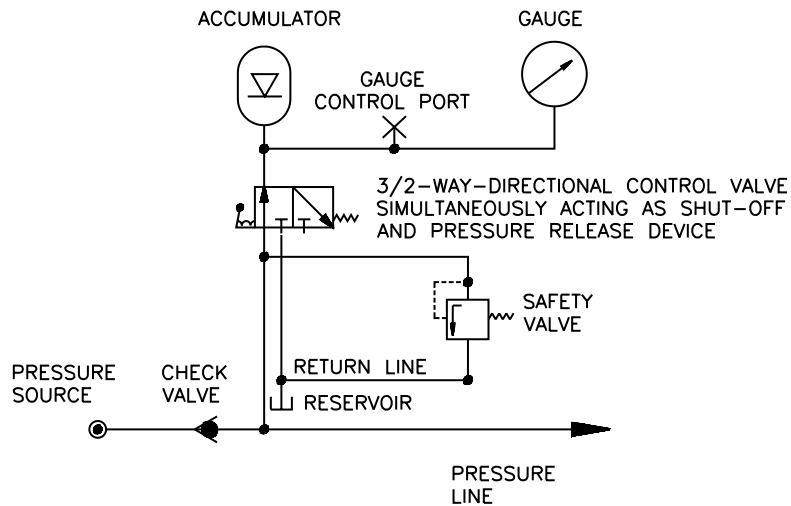

Configuration with a 3/2-way-directional-control which simultaneously serves to isolate the accumulator from the pressure line and release pressure to the return line. The safety valve is permanently communicating with the pressure line, therefore also protecting the circuit. The accumulator is either protected by the safety valve or connected to the return line.

Example 4

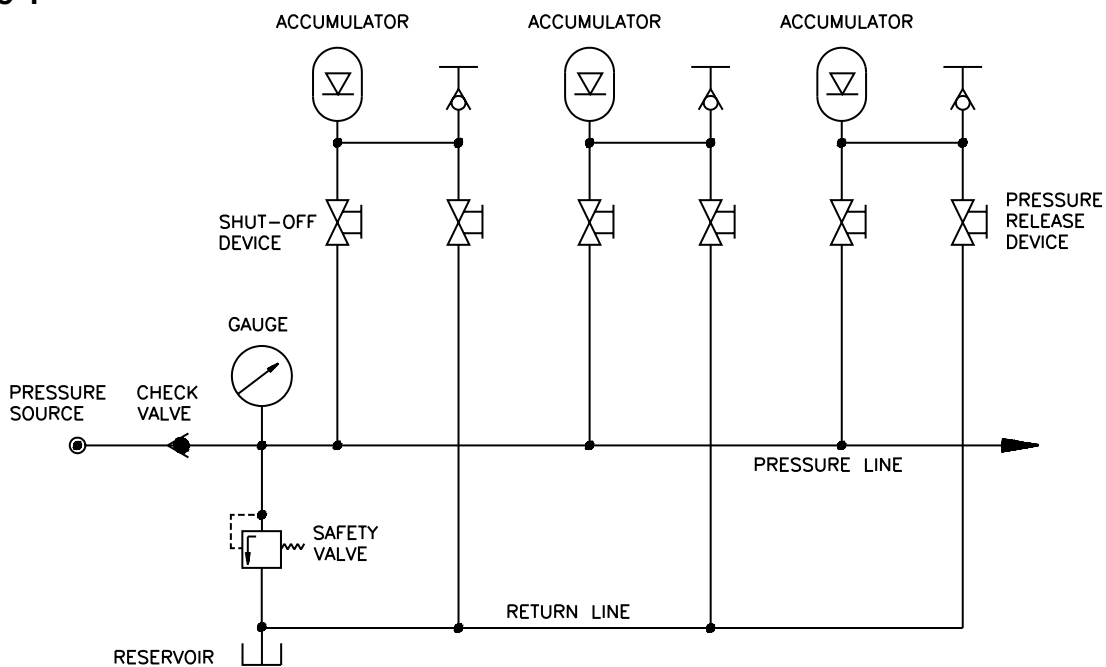

The above configuration shows a group of several accumulators connected with a single pressure line which is permanently connected with a gauge and a safety valve. Each individual accumulator may be isolated from the pressure line by a shut-off device and released by a pressure device to a return line for maintenance purposes. An external control gauge connected to a quick coupling allows observation of the pressure at the fluid port of each individual accumulator.

Example 5

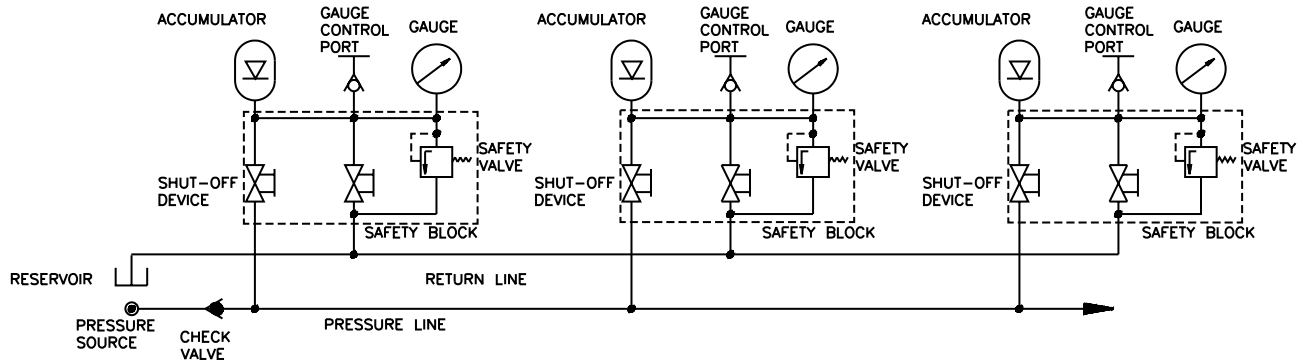

Configuration similar to example 1 but with several accumulators each equipped with a safety block. Each safety block includes a safety valve, shut-off device, pressure release device and ports for the pressure line, the return line, gauge, control gauge and the accumulator itself. This configuration meets all safety requirements even for several pressure sources.

Example 6

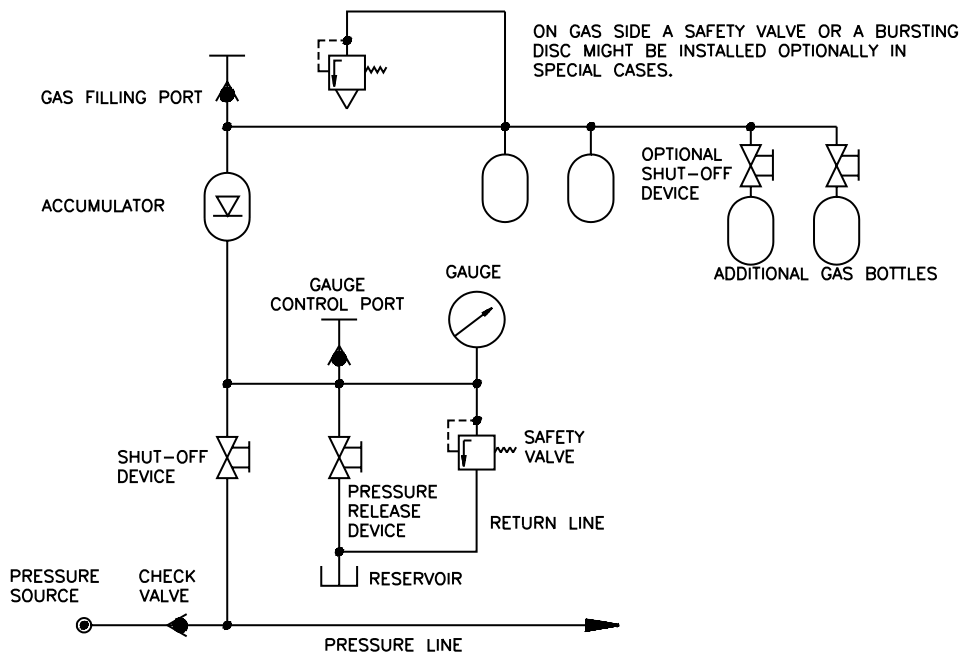

Configuration for a transfer type accumulator with additional gas bottles. Safety equipment for filling procedures is not shown.

Pre-Charging

Use only an inert gas such as nitrogen for precharging piston accumulators. **Do not use oxygen or shop air. included.**

If water pumped nitrogen is not available, oil-pumped nitrogen may be used. (C.G.A. Standards: Nitrogen gas bottles for water pumped nitrogen has a right-hand valve thread which requires charging and gauging assembly †144595XX00 for units up to 3000 PSI. Oil-pumped nitrogen requires a left-handed valve thread (use †144596XX00).

It is recommended to use charging and gauging assembly as shown in Figure 1 (Part †144595XX00, right-hand thread; Part †144596XX00, left-hand thread), and in Figure 4 Part †087100XX00 for 1-15 gallon & Part †087102XX00 for 10-150 cu. in. accumulator rated for 3,000 PSI or less. For accumulators rated for 5,000 PSI, as well as the 25-40 gallon, 3,000 PSI accumulators, use assembly shown in Figure 6 (Part †870816XX00). If other equipment is used, make sure it is compatible with the gas valve assembly and nitrogen source. All components must be rated for a pressure at least as high as the nitrogen source. **It is strongly recommended that the nitrogen bottle used have the appropriate pressure high pressure regulator (not included).**

Make sure nitrogen supply is shut off. Attach hose to nitrogen bottle. If accumulator has a gas valve as shown in Figure 8A or 8B, follow steps A through L and skip steps F and J. If accumulator has a gas valve as shown in Figure 9, follow steps A through L and skip steps E and I.

Accumulators having gas valve per Figure 8A or 8B

- (A) Remove gas valve guard and gas valve cap.
- (B) Back gas chuck "T" handle all the way out (counterclockwise) before attaching charging assembly to accumulator gas valve.
- (C) Close bleed valve.
- (D) Making sure not to loop or twist the hose, attach swivel nut to gas valve and tighten (10-15 in. lb.) (11.5-17 cm kg).
- (E) Turn gas chuck "T" handle until the gauge starts showing the pressure in the accumulator. Do not turn the "T" handle all the way down, as it will damage the valve core.
- (F) **For gas valves as shown in Figure 9**, hold gas valve at point "C" with one (1) wrench while unscrewing hex nut at point "D" with a second wrench. This will open the poppet inside the gas valve. Note: Three (3) turns will fully open the valve.
- (G) Crack open nitrogen bottle or regulator valve and **slowly** fill accumulator. **Caution:** If the precharge is not done slowly, the bladder may suffer permanent damage. Shut off when gauge indicates 100 PSI above desired precharge. (Note: It is recommended that precharge pressure be at least 25% of maximum system pressure.) Damage to bladder may occur if this ratio is not maintained or exceeded. For shock suppression applications, precharge is usually set at about 65% of system pressure. When the accumulator is used to supplement pump flow, auxiliary power supply or leakage compensation, precharge is usually set at approximately 90% of minimum system pressure.
- (H) Let the precharge set for 10 to 15 minutes. This will allow the gas temperature to stabilize. If the desired precharge is exceeded, close nitrogen bottle valve, then slowly open bleed valve. Do not reduce precharge by depressing valve core with a foreign object. High pressure may rupture rubber valve seat.

† "XX" Denotes to gauge pressure.

- (I) When finished precharging accumulator, turn "T" handle all the way out on gas chuck, then open bleed valve. not
- (J) For gas valves as shown in Figure 9, with a wrench, tighten hex nut at point "D" to close internal poppet (5-8 ft. lbs.) (5.7- 9.2 cm kg).
- (K) Hold gas valve to keep from turning, loosen swivel nut, remove assembly. Check for precharge leak using a common leak reactant.
- (L) Replace gas valve cap (10-15 in. lbs.) (11.5-17 cm kg) and valve guard. (Gas valve cap serves as a secondary seal.)

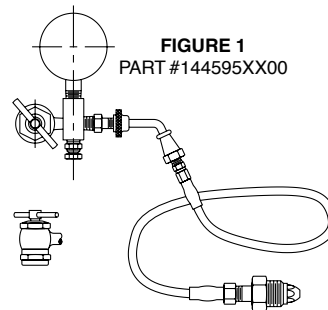

FIGURE 1
PART #144595XX00

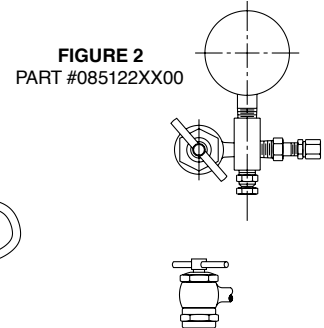

FIGURE 2
PART #085122XX00

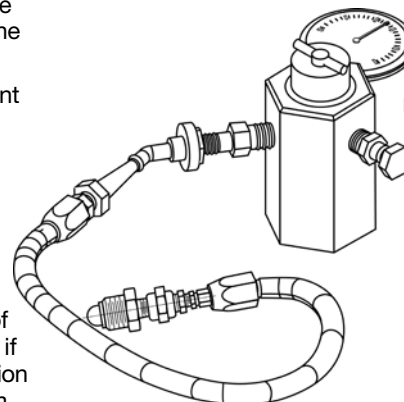

FIGURE 4
PART #087100XX00 (1-15 GAL.)
PART #087102XX00 (10-150 CU. IN.)

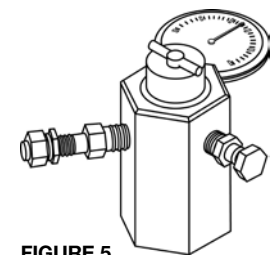
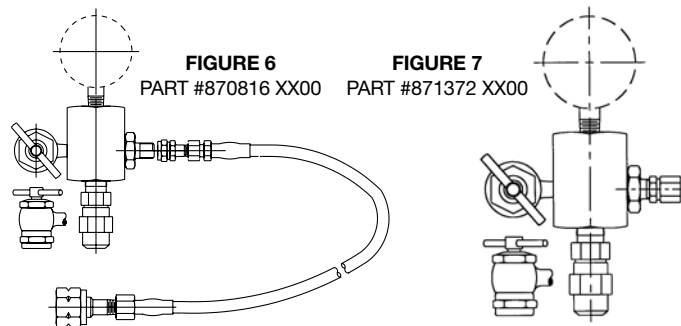

FIGURE 5
PART #087101XX00 (1-15 GAL.)
PART #087103XX00 (10-150 CU. IN.)

**CAN BE USED ON BOTTOM AND TOP REPAIRABLE
 3,000 PSI ACCUMULATORS**

Part Number 144595 XX00 (Std) (Right Hand)	Charging and Gauging Assembly for 3000 PSI Bottom Repairable Charging and Gauging Assembly consists of 10' charging hose with standard right-hand thread nitrogen fittings adapter incorporating gas valve bleeder valve and gas chuck (less gauge). For left-hand thread nitrogen bottle fitting specify part number 144596 XX00.
Part Number 087102 XX00 (10-150 cu. in.) 087100 XX00 (1-15 gal.)	Charging and Gauging Assembly for 3000 PSI Bottom & Top Repairable Charging and Gauging Assembly consists of 10' charging hose with standard right-hand thread nitrogen fittings adapter incorporating gas valve bleeder valve and gas chuck (less gauge).
Part Number 085122 XX00	Gauging Assembly for 3000 PSI Bottom Repairable Gauging device consisting of adapter incorporating gas valve bleeder valve and gas chuck including gauge.
Part Number 087103 XX00 (10-150 cu. in.) 087101 XX00 (1 - 15 gal.)	Gauging Assembly for 3000 PSI Top Repairable Gauging device consisting of adapter incorporating gas valve bleeder valve and gas chuck (less gauge).



25 - 40 GALLON 3000 PSI AND ALL 5000 PSI UNITS

Part Number 870810 XX00	Charging and Gauging Assembly for 25-40 Gal. 3000 & 5000 PSI Charging and Gauging Assembly consists of 10' charging hose with standard right-hand thread nitrogen fittings (1.035-14 NGO female) adapter incorporating gas valve bleeder valve and gas chuck (less gauge).
Part Number 871372 XX00	Gauging Assembly for 5000 PSI Gauging device consisting of adapter incorporating gas valve bleeder valve and gas chuck (less gauge).

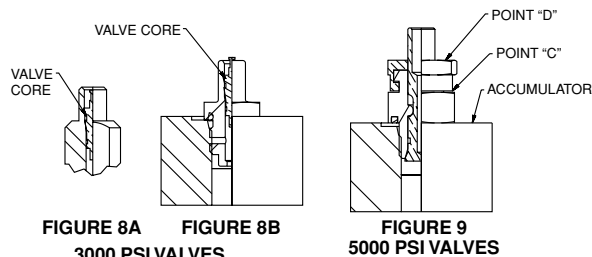

Maintenance

Little maintenance is required for a bladder accumulator. If there is external leakage, tighten all connections. If leakage continues, remove accumulator from system and replace faulty components. After original installation, check pre-charge once during first week to see that no leak has developed. Thereafter, check pre-charge monthly. Check pre-charge if the system is acting sluggish. If pre-charge is low, check gas valve for leakage and recharge. If there is no gas in bladder and fluid appears at gas valve, unit must be removed and bladder replaced.

Pre-charge Checking Procedure

Using appropriate valve in the hydraulic system, discharge all oil from accumulator.

For accumulators rated for 3000 PSI, either use gaging assembly in Figure 2 (Part #085122XX00) or gaging assembly in Figure 5 (Part #087101XX00) and follow Steps 1 through 7.

For accumulators rated for 5000 PSI, use gaging assembly in Figure 7 (Part #871372XX00) and follow steps 8 through 14.

3000 PSI RATED UNITS

- (1) Remove gas valve guard and gas valve cap.
- (2) Close bleed valve and turn "T" handle all the way out.
- (3a) Attach gauging assembly to gas valve or to gas valve extension and tighten swivel nut (10-15 in. lb.) (11.5-17 cm kg), when using gauging assembly in Figure 1.
- (3b) Install gas valve o-ring on the gas valve, and attach gauging assembly to valve stem. Tighten assembly (25-30 in. lb.) (29-35 cm kg) when using gauging assembly in Figure 4.
- (4) Turn "T" handle all the way down, which will depress core in gas valve and check pressure.
- (5) To remove gauging assembly, turn "T" handle all the way out and then open bleeder valve.
- (6) Hold gas valve from turning, loosen swivel nut and remove assembly.
- (7) If necessary, remove valve extension, then install cap on gas valve (10-15 in. lb.) (11.5-17 cm kg) and valve guard.

25-40 GALLON 3000 PSI AND 5000 PSI RATED UNITS EQUIPPED WITH MS GAS VALVE AS SHOWN IN FIGURE 9.

- (8) Remove gas valve guard and gas valve cap.
- (9) Close bleed valve.
- (10) Attach gauging assembly to gas valve and tighten swivel nut (10-15 in. lb.) (11.5-17 cm kg).
- (11) Referring to Figure 9, hold gas valve at point "C" with one (1) wrench while unscrewing hex nut at point "D" with a second wrench. This will open the poppet inside the gas valve. Note, four (4) turns will fully open poppet. Check pre-charge pressure.
- (12) With wrench, tighten hex nut at point "D" to close internal poppet (10-15 in. lb.) (11.5-17 cm kg).
- (13) Hold gas valve at point "C" with a wrench and remove swivel nut assembly.
- (14) Replace cap on gas valve (10-15 in. lb.) (11.5-17 cm kg) and install gas valve guard.

Removal of Accumulator From Hydraulic System

Shut equipment down and make certain that hydraulic pressure at the accumulator is at zero.

Remove gas valve guard and gas valve cap.

3000 PSI RATED UNITS

Accumulators rated for 3000 PSI will have a gas valve as shown in Figure 8A or 8B. For these units, attach gaging assembly (Part #085122XX00) or (Part #087103XX00) for 10 - 150 cubic inch, and (Part #087101XX00) for 1-15 gallon.

Open bleed valve and release all the gas pressure. Detach gauging assembly and, using valve core removing tool (Part #582441XX00), **remove valve core.**

Remove accumulator from hydraulic system.

25-40 GALLON 3000 PSI AND 5000 PSI RATED UNITS EQUIPPED WITH MS GAS VALVE AS SHOWN IN FIGURE 9.

Accumulators rated for 5000 PSI will have a gas valve as shown in Figure 9. For these units, after removing valve cap, hold valve at point "C" with one (1) wrench while unscrewing hex nut at point "D" with a second wrench until gas begins to escape through the top of the valve. Wait until all the gas pressure has been released. (Caution: Keep face away from gas valve as the high pressure nitrogen is discharging.)

Remove accumulator from hydraulic system.

Disassembly of Bottom Repairable Accumulators

Figure 1. Once the accumulator has been removed from the equipment, the accumulator body should be secured in a vise, preferably a chain vise. If a standard jaw vise is used, brass inserts should be used to protect the accumulator hydraulic port assembly from damage. Clamp on wrench flats only when using a jaw vise to prevent accumulator from turning.



FIGURE 1

Figure 2. Remove bleeder plug (if the accumulator is equipped with one) on hydraulic port assembly. Using a spanner wrench, remove lock nut from the hydraulic port assembly; use an adjustable wrench on the flats located on the port assembly to prevent port assembly from rotating.



FIGURE 2

Figure 3. Remove spacer, then push the hydraulic port assembly into the shell prior to Step 4.



FIGURE 3

Figure 4. Insert hand into the accumulator shell and remove the o-ring backup, o-ring, metal backup. Separate the anti-extrusion ring from the hydraulic port. Fold anti-extrusion ring to enable removal of anti-extrusion ring from shell.



FIGURE 4

Figure 5. Remove hydraulic port plug from accumulator shell.



FIGURE 5

Figure 6. Remove jam nut from bladder valve stem. Secure valve stem from twisting with an appropriate wrench applied to the valve stem flats.



FIGURE 6

Figure 7. Fold bladder and pull out of accumulator shell. A slight twisting motion while pulling on the bladder reduces effort required to remove bladder from shell. If bladder is slippery, hold with a cloth.



FIGURE 7

Clean & Inspect

Cleaning: All metal parts should be cleaned with a cleaning agent. Seals and soft parts should be wiped clean.

Bladder: Inflate bladder to normal size. Wash bladder with a soap solution. If soap solution bubbles, discard bladder. After testing, deflate bladder immediately.

Hydraulic Port: Inspect assembly for damage; check the poppet plunger to see that it spins freely and functions properly.

In cases where the accumulator is used with water, check assembly for rust and/or defective plating. If rust is detected, clean with commercial rust remover. If parts are pitted, replace with new components. If protective plating is damaged, replace with new components.

Seals: Check anti-extrusion ring and soft seals for damage and wear; replace all worn or damaged seals with original equipment seals from the Hydraulic Accumulator Division.

Shell: After shell has been cleaned with a cleansing agent, check the inside and outside of shell. Special attention should be given to the area where the gas valve and hydraulic assembly pass through the shell. Any nicks or damages in this area could destroy the accumulator bladder or damage new seals. If this area is pitted consult factory.

Bladder Assembly in Bottom Repairable Accumulators

1. After shell has been cleaned and inspected, replace accumulator shell in vise or on table.
2. Spray the inside of the accumulator shell with approximately 10% of the accumulator volume with clean system fluid to lubricate and cushion bladder. Make sure the entire internal of the shell is lubricated.

3. With all gas completely exhausted from bladder, collapse bladder and fold longitudinally in a compact roll.



FIGURE 8

4. **Figure 8.** Insert the bladder pull rod through the valve stem opening and through the shell fluid port; attach the bladder pull rod to the bladder valve stem.

5. With one hand, pull the bladder pull rod while feeding the bladder into the shell with the other hand. Slight twisting of bladder will assist in this insertion.



FIGURE 9

6. **Figure 9.** Once the bladder valve stem has been pulled through the valve stem opening in the shell, install the valve stem nut by hand. Once the valve stem nut is in place, remove the bladder pull rod.

Disassembly of Conventional Top-Repairable Accumulators

The conventional top-repairable accumulator uses a gas-end adapter which is retained in the shell with an anti-extrusion ring exactly like those used in port assemblies (see **Figure 10**).

1. Make sure the gas is relieved from the accumulator. (See Removal of Accumulator from System).
2. Remove jam nut from bladder gas valve stem using a 1-5/16" socket wrench.

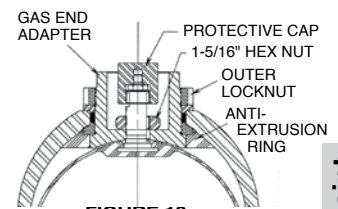

FIGURE 10

- Using a spanner wrench, remove outer lock nut on the gas end adapter.
- Push the gas end adapter complete with the bladder into the shell.
- Insert hand into accumulator, remove the o-ring back-up, o-ring and metal back-up. Separate the anti-extrusion ring from the gas end adapter.
- Fold the anti-extrusion ring and remove from shell. See **Figure 4**.
- Remove gas end adapter from shell.
- Remove bladder from shell.
NOTE: Conventional top repairable accumulators may be repaired by removing the bladder from either the hydraulic end or the gas end of the accumulator.

Clean & Inspect

Cleaning: All metal parts should be cleaned with a cleaning agent. Seals and soft parts should be wiped clean.

Bladder: Inflate bladder to normal size. Wash bladder with a soap solution. If soap solution bubbles, discard bladder. After testing, deflate bladder immediately.

Hydraulic Port: Inspect assembly for damage; check the poppet plunger to see that it spins freely and functions properly. In cases where the accumulator is used with water, check assembly for rust and/or defective plating. If rust is detected, clean with commercial rust remover. If parts are pitted, replace with new components. If protective plating is damaged, replace with new components.

Seals: Check anti-extrusion ring and soft seals for damage and wear; replace all worn or damaged seals with original equipment seals from the Accumulator Division.

Shell: After shell has been cleaned with a cleansing agent, check the inside and outside of shell. Special attention should be given to the area where the gas valve and hydraulic assembly pass through the shell. Any nicks or damages in this area could destroy the accumulator bladder or damage new seals. If these areas are pitted, consult factory.

Bladder Assembly in Conventional Top-Repairable Accumulators

- Spray the inside of the accumulator shell with a liberal amount of clean system hydraulic fluid to lubricate and cushion the bladder. Make sure the entire internal surface of the shell is lubricated.
- With all air completely exhausted from bladder, collapse bladder and fold longitudinally in a compact roll.
- Install the gas end adapter on the bladder and secure with jam nut.
- Insert bladder into accumulator shell.
- Insert gas end adapter.
- Fold anti-extrusion ring and place inside accumulator.
- Reaching inside the accumulator, insert the gas end adapter through the anti-extrusion ring and pull into place. The steel surface on anti-extrusion ring should face outward.
- Holding the gas end adapter in place, fill accumulator with approximately 50 PSI nitrogen. This will hold the gas end adapter in place.
- Install the metal backup, o-ring and o-ring backup.
- Install the outer spacer.
- Install the outer locknut.

Hydraulic Port Assembly Installation

- Holding the hydraulic port assembly by the threaded end, insert the poppet end into the shell fluid port. Lay complete assembly inside shell.



FIGURE 11

- Figure 11.** Fold anti-extrusion ring to enable insertion into the shell. Once the anti-extrusion ring has cleared the fluid port opening, place the anti-extrusion ring on the poppet assembly with the steel collar facing toward the shell fluid port.



FIGURE 12

- Pull the threaded end of the port assembly through the shell fluid port until it seats solidly into position on the shell fluid port opening.

- Figure 12.** With port assembly firmly in place, install valve core into the bladder stem. Slowly pressurize the bladder, using dry nitrogen with sufficient pressure (approximately 40-50 PSI) to hold poppet assembly in place so both hands are free to continue with assembly.



FIGURE 13

- Figure 13.** Install metal backup washer over hydraulic port assembly and push into the shell fluid port to bottom it out on anti-extrusion ring.



FIGURE 14

- Install o-ring over hydraulic port assembly and push it into the shell fluid port until it has bottomed out against washer.
CAUTION: Do not twist o-ring.
- Install o-ring backup over hydraulic port assembly and push until it bottoms against o-ring (1-40 gallon sizes and 5K only).
- Insert spacer with the smaller diameter of the shoulder facing the accumulator shell.
- Figure 14.** Install the lock-nut on the hydraulic port assembly and tighten securely. This will squeeze the o-ring into position. Use appropriate wrench on flats of port assembly to insure the unit does not turn.
- Thread bleeder plug into the hydraulic port assembly.
- Position accumulator so that fluid (same fluid as used in the system) can be poured into the accumulator (add approximately 10% of the accumulator capacity). This fluid will act as a cushion when the accumulator is pre-charged with gas.
- Pre-charge accumulator to desired pressure. See pre-charge instructions. Install accumulator on machine.

Accumulator Parts Description

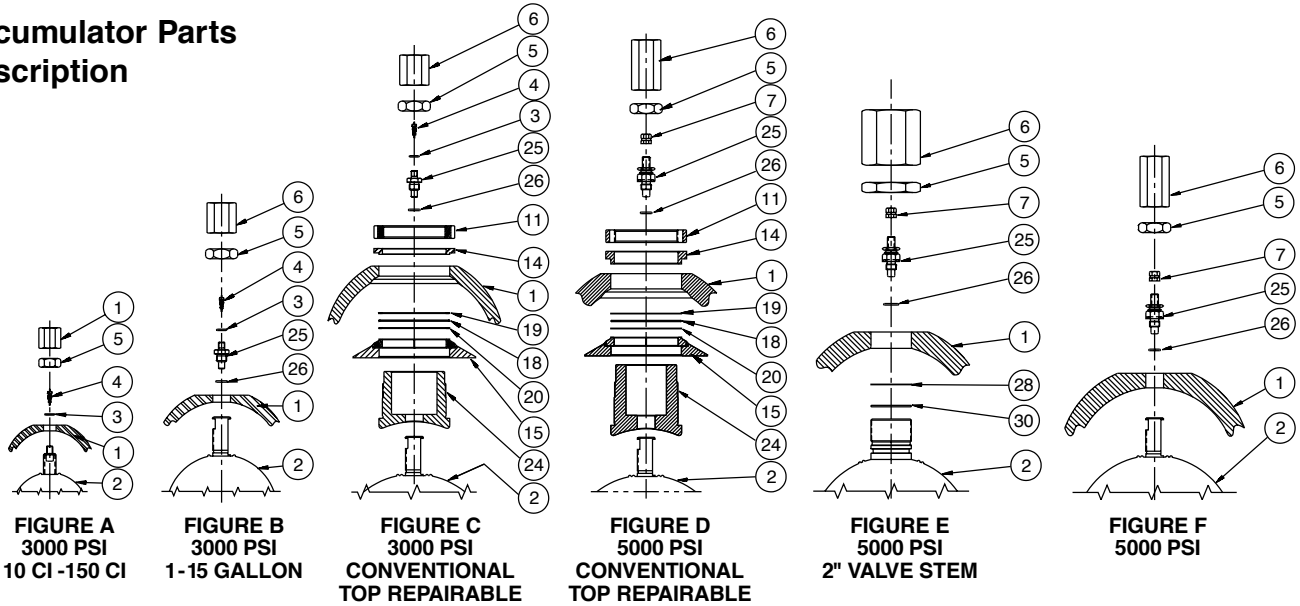

Item No.	Description
1	Shell
2	Bladder
3	O-ring
4	Valve Core
5	Lock Nut (Jam)
6	Protective Cap
7	Valve Cap
11	Lock Nut Outer
14	Spacer
15	Anti-Extrusion Ring Ass'y.
18	O-ring
19	O-ring Back-up
20	O-ring Back-up Metal
24	Top Adapter
25	Gas Valve
26	O-ring (Gas Valve)
28	Back-up Washer (Stem)
30	O-ring (Stem)

Suggested Approximate Torque Values

Protective Cap	14 ft. lbs.
Lock Nut (Jam)	56 ft. lbs.
Valve Core	3-4 in. lbs.
Bleeder Plug	10 ft. lbs.
Lock Nut Outer (1 qt.)	73 ft. lbs.
Lock Nut Outer (1 gal.)	200 ft. lbs.
Lock Nut Outer (2 1/2-15 g.)	275 ft. lbs.
Gas Valve Cap	10-15 in. lbs.

Bladder Assembly Part Numbers

Accumulator Size	Seal Type				
	- 01 Nitrile (NBR)	- 04 Hydrin	- 06 Butyl	- 08 EPR	- 28 Fluorocarbon
3000 PSI - Standard - Ref. Figures A, B & C. Contains Items 2,3,4,18,19,20,25 & 26*					
10 Cu. In.	702900	702902	702903	702904	702906
1 Pt.	702914	702916	702917	702918	702920
1 Qt.**	702928	702930	702931	702932	702934
150 Cu. In.	702942	702944	702945	702946	702948
1 Gal.***	702956	702958	702959	702960	702962
2 1/2 Gal.	702970	702972	702973	702974	702976
5 Gal.	702984	702986	702987	702988	702990
10 Gal.	702998	703000	703001	703002	703004
11 Gal.	703012	703014	703015	703016	703018
15 Gal.	703026	703028	703029	703030	703032
25 Gal.	703340	704008	704009	703341	703342
40 Gal.	703346	704014	704015	703347	703348
5000 PSI - Ref. Figure D and contains Items 2,7,25 & 26					
2 1/2 Gal.	0870445025	0870485025	0870455025	0870475025	0870465025
5 Gal.	0870445050	0870485050	0870455050	0870475050	0870465050
10 Gal.	0870445100	0870485100	0870455100	0870475100	0870465100
15 Gal.	0870445150	0870485150	0870455150	0870475150	0870465150
5000 PSI - 2" Valve Stem Ref. Figure E Contains Items 2,7,25,26,28 & 30					
1 Gal. 7/8" Ø Stem	8706135010	8706175010	8706145010	8706145010	8706155010
1 Gal. 1" Ø Stem	704060	704062	704063	704064	704066
2 1/2 Gal.	706000	706002	706003	706004	706006
5 Gal.	706010	706012	706013	706014	706016
10 Gal.	706020	706022	706023	706024	706026
15 Gal.	707030	706032	706033	706034	706036
5000 PSI - Ref. Figure F Contains Items 2,7,25 & 26					
2 1/2 Gal.	0850695025	0856665025	0850705025	0851055025	0851045025
5 Gal.	0850695050	0856665050	0850705050	0851055050	0851045050
10 Gal.	0850695100	0856665100	0850705100	0851055100	0851045100
15 Gal.	0850695150	0856665150	0850705150	0851055150	0851045150

*See page 140 for items 18-20.

Contains items 2,3, & 4 as shown in Figure A. *Contains items 2,3,4,18,19,25 & 26.

Gas Valve Assembly Part Numbers

Size	Pressure	Seal Type				
		Buna-Nitrile -01	Butyl -06	Fluorocarbon -28	EPR -08	Hydrin -04
10 - 150 C.I.	3000 PSI	NA	NA	NA	NA	NA
1 - 15 Gal.†	3000 PSI	L074210001	L074210003	L074210005	L074210007	L074210009
25 - 40 Gal.▲	3000 PSI	L074400001	L074400003	L074400005	L074400007	L074400009
1 - 15 Gal.▲	5000 PSI	L074400001	L074400003	L074400005	L074400007	L074400009

† Contains items 3, 4, 25 & 26.

▲ Contains items 7, 25 & 26.



Accumulator Parts Description

Item No.	Description
1	Shell
8*	Oil Port Assembly
9**	Poppet & Plug Assembly
10	Oil Port (Machined)
11	Lock Nut Outer
12	Valve Poppet
13	Piston Poppet
14	Spacer
15	Anti-Extrusion Ring Assembly
16	Elastic Stop Nut
17	Spring Poppet
18	O-ring
19	O-ring Back-up
20	O-ring Back-up Metal
22***	Bleeder Plug
23	Dust Cap Oil Port
27	O-Ring (SAE Bleed Plug)

* Oil Port Assembly contains items 10 through 23.

** Port & Poppet Assembly contains items 10, 12, 13, 16, 17, 22 & 23.

*** Bleeder Plug for SAE straight thread port assemblies will also contain an o-ring (Item 27).

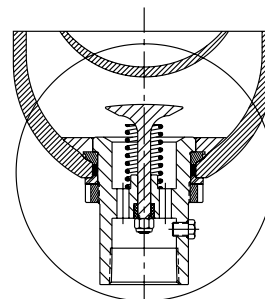
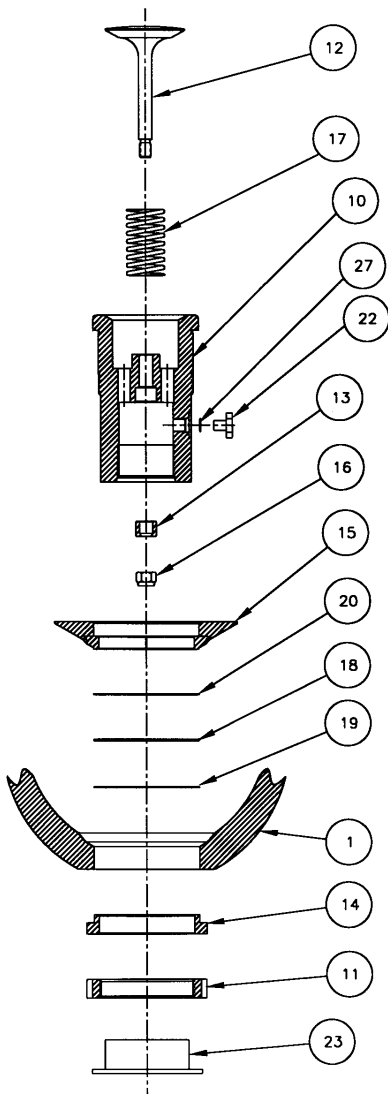

Accumulator Accessories

Description	Part No.
Pull Rod (1 Qt-2 1/2 Gal)	085109 0250
Pull Rod (5 Gal)	085109 0500
Pull Rod (10-11 Gal)	085109 1000
Pull Rod (15 Gal)	085109 1500
Core Repair Tool	582441 0000
Core Installation Tool	300987
Spanner Wrench	085110 0000

Accumulator Repair Tools

1. Bladder Pull Rods—(Bladder Type Accumulator) Pull Rods are available in single or multiple lengths for different size accumulators. The pull rods attach to the gas valve of the bladder for ease of assembly into shell during reassembly.
2. Core Tool—The core tool is used to remove and reinstall the valve core. It is also used to ream valve seat and repair threads.
3. Spanner Wrench—Fits all standard size bladder accumulators. Used to remove hydraulic poppet assembly from accumulator shell.

Oil Port Assembly Part Numbers

3000 PSI Accumulators		Seal Type					Port & Poppet Assemblies
Accumulator Size	Port	-01 Buna-Nitrile	-04 Hydrin	-06 Butyl	-08 EPR	-28 Fluorocarbon	
10 Cu. In.	3/4" NPT - Male	L076741*01	L076749*01	L076743*01	L076747*01	L076745*01	L076740*01
10 Cu. In.	SAE #8	L076741*02	L076749*02	L076743*02	L076747*02	L076745*02	L076740*02
1 Pt. - Qt.	3/4" NPT	L075031*01	L075039*01	L075033*01	L075037*01	L075035*01	L075030*01
1 Pt. - Qt.	SAE #12	L075031*02	L075039*02	L075033*02	L075037*02	L075035*02	L075030*02
150 Cu. In.	1" NPT	L074151*01	L074159*01	L074153*01	L074157*01	L074155*01	L074350*01
150 Cu. In.	SAE #16	L074151*02	L074159*02	L074153*02	L074157*02	L074155*02	L074350*02
1 Gal.	1 1/4" NPT	L074161*01	L074169*01	L074163*01	L074167*01	L074165*01	L074360*01
1 Gal.	SAE #20	L074161*02	L074169*02	L074163*02	L074167*02	L074165*02	L074360*02
1 Gal.	1 1/4" SAE Split Flange	L074161*03	L074169*03	L074163*03	L074167*03	L074165*03	L074360*03
2 1/2 - 15 Gal.	2" NPT	L074171*01	L074179*01	L074173*01	L074177*01	L074175*01	L074370*01
2 1/2 - 15 Gal.	SAE #24	L074171*02	L074179*02	L074173*02	L074177*02	L074175*02	L074370*02
2 1/2 - 15 Gal.	2" SAE Split Flange	L074171*03	L074179*03	L074173*03	L074177*03	L074175*03	L074370*03
2 1/2 - 15 Gal.	1 1/4" NPT	L074171*04	L074179*04	L074173*04	L074177*04	L074175*04	L074370*04

* = "O" (Std.) Oil Service

* = "S" Water/Chem. Service



Oil Port Assembly Part Numbers

330 Bar Accumulators		Seal Type					Port & Poppet Assembly
Accumulator Size	Port	-01 Buna-Nitrile	-04 Hydrin	-06 Butyl	-08 EPR	-28 Fluorocarbon	
0.16 Liter 0.16 Liter	3/4" NPT Male SAE # 8	Consult Factory					L076740*01 L076740*02
0.5 -1 Liter 0.5 -1 Liter	3/4" NPT SAE # 12						L075030*01 L075030*02
2.5 Liter 2.5 Liter 2.5 Liter	1" BSPP SAE # 16 Metric 33 x 2						E074350*02 E07435B*01 E07435M*01
4 Liter 4 Liter 4 Liter 4 Liter	1-1/4" BSPP SAE # 16 1-1/4" SAE Code 62 Metric 42 x 2						E074360*02 E07436B*01 E074360*03 E07436M*01
10 - 50 Liter 10 - 50 Liter 10 - 50 Liter 10 - 50 Liter	2" BSPP SAE # 24 1-1/2" SAE Code 62 Metric 48 x 2						E074370*02 E07437B*02 E074370*03 E07437M*01

* = "0" (Std.) Oil Service * = "S" Water/Chem. Service

Accumulator Sizing and Selection Software

Parker offers leading edge application assistance, in the form of the InPHorm Accumulator Sizing and Selection Software or visit www.parker.com/accumulator for more information. For further product application assistance, contact Parker's Accumulator Technical Support Group at (815) 636-4100.

Accumulator Seals

Bladder accumulators are available for use with many operating medias. Fluid should be a non-dangerous liquid as well as precharged with an inert gas such as nitrogen.

Water & Chemical Service Option (W)

Bladder accumulators are available with a water and chemical resistance options. The (W) designation includes an internally Skotchkoted shell and stainless steel port assembly. The Skotchkote offers added protection against more corrosive fluids. Consult factory for details.

Bladder Storage

The shelf life of bladders under normal storage conditions is 1 year. However, this period can be extended to 2 years, if the storage conditions are improved.

Normal storage condition consists of the bladder being heat sealed in a black plastic bag and placed in a cool dry place away from sun, ultraviolet and fluorescent light that can cause the bladder to weather check and dry rot, which appear on the bladder surface as cracks.

Extended life can be achieved by having the bladder charged with nitrogen to its full size, and placing it in a heat sealed 5 mil thick black plastic bag. The air in the plastic bag shall be purged using nitrogen prior to sealing. The bag must then be placed in an appropriate size cardboard box, sealed and kept in a cool and dry place away from sunlight and ozone producing equipment.

“U” Bolts for Piston & Bladder-Type Accumulators

Accumulator Models (3000 PSI) Bladder Size	“U” Bolt Part Number	Dimensions						Wt. (lbs.)
		A	B	C	D	E	Thrd.	
1 Pint	0862090000	1/2	3-11/16	4-1/16	3-5/8	2	3/8-16	0.9
1 Quart	0854380000	1/2	4-5/8	5-1/8	4-1/2	3	1/2-13	1.2
1 Gallon	0854390000	5/8	6-3/4	7	6-1/8	3-3/4	5/8-11	2.4
2½ -15 Gal.	0853360000	5/8	9.0	9-5/8	7-1/8	3-3/4	5/8-11	3.0

Bladder-Type Accumulator

Bladder-type accumulators should be mounted vertically with the hydraulic port down.

CAUTION: Bladder-type accumulators should never be mounted more than 25° angle from the vertical.

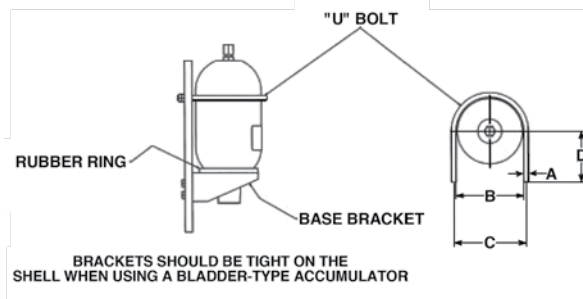

Base Bracket Assembly for Bladder Accumulators

Accumulator Models Bladder Size	Base Bracket Assembly Part Number	Dimensions								Wt. Lbs.
		A	B	C	D	E	F	G	H	
1 Gal. (3K)	1449100000	10.3	7.87	3.62	4.75	8.87	3.85	1.58	0.65 x .87	5
2½ -15 Gal. (3K)	1448720000	10.3	7.87	4.84	6.75	8.87	3.85	1.58	0.65 x .87	5

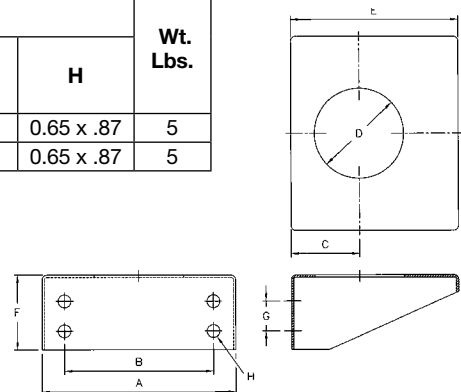

Clamp Brackets for Small Bladder Accumulators

Bladder Size Cubic Inches	Part No.	Dimensions				
		A	B	C	D	H
10	8700110238	4.25	3.35	4.29	2.25 / 2.41	1.58
30	8700110358	5.00	3.94	5.62	3.50 / 3.62	2.28

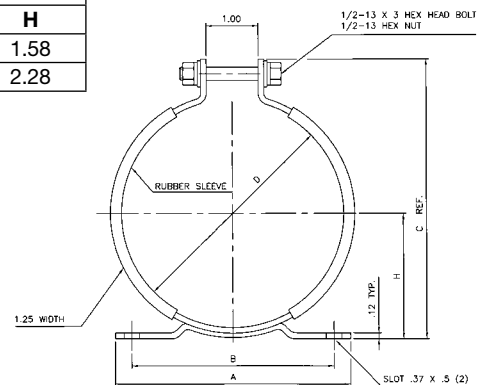

Clamp Brackets for Bladder-Type Accumulators

Bladder Size	Clamp Part No.	Dimensions							Wt. Lbs.
		A	B	C Max.	D Max.	E	F	G	
1 Qt., 150 C.I. (Figure A)	1466230000	4.5	3.9	5.5	6.3	2.6	.35 x .51	1.2	1.8
1 Gal. (Figure A)	1449080000	6.8	6.3	7.6	8.5	3.6	.35 x .51	1.2	2.7
2½ - 15 Gal. (3K) (Figure B)	1449070000	9.0	8.5	10.0	11.7	4.8	.50 x .75	1.2	4.2
2½ - 15 Gal. (5K) (Figure B)	1349200000	9.5	8.5	10.5	12.0	5.4	.50 x .75	1.2	4.5

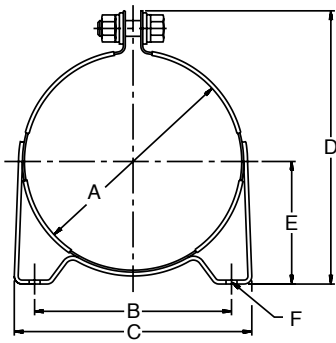

Figure A

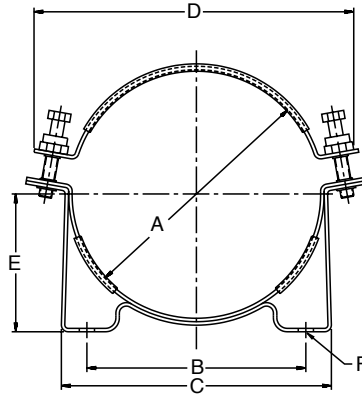

Figure B

