

# Bladder Accumulators



Bladder

## IN THIS SECTION

Overview	51
Specifications	52
<b>Models, Capacities &amp; Dimensions</b>	
Bottom Repairable	54
Top Repairable	55
High-flow	56
Transfer Barrier	57
Gas Bottles	58
Options & Accessories	59
Replacement Kits	63
Ordering Information	64

## Features

- Operating Pressures to 6600 PSI
- Ten Different Capacities from 10 cu in to 15 gallons
- Eight Different Configurations
- Highest Quality In-House Manufactured Bladders
- ASME Certification Standard, 1 Gallon & Up
- Water/Chemical Service Available, with Stainless Steel Ports
- Five Bladder Compounds to Suit a Variety of Fluids & Temperatures
- Certifications Available: CE, CRN, AS1210, SELO, ABS, DNV, GOST
- Temperatures -40° to 250° F



**Specifications**

Bladder accumulators are suitable for storing energy under pressure, absorbing hydraulic shocks, and dampening pump pulsation and flow fluctuations. Bladder accumulators provide excellent gas and fluid separation ensuring dependable performance, maximum efficiency, and long service life.

**Why Use Bladder Accumulators?**

- improves system efficiency
- supplements pump flow
- supplies power in emergency
- compensates for leakage
- absorbs hydraulic shocks
- highly contaminant tolerant
- universal application
- high/low temperature tolerance
- safety, cannot be disassembled under pressure
- very quick response
- works well with water, low lubricity fluids
- wide range of compounds for a variety of fluids

**Bladder Accumulators  
Introduction**

**GRB Bladder Products...  
The Original and still the Best!**

The Greer bladder style accumulator is the industry's original, and still the best! For years this style of accumulator has served both the industrial and mobile hydraulic markets, providing a proven design for many hydraulic system applications.

The Greer bladder product line offers the broadest line of quality products, including:

- 3000 & 5000 PSI Bottom Repairable
- 3000 & 5000 PSI Top Repairable
- 3000 PSI High-flow
- 3000 PSI Transfer Barrier
- 3000 & 5000 PSI Gas Bottles
- A Wide Array of Options and Accessories

Greer bladder products maintain the highest quality because of our **in-house** bladder molding operations. The heart of the bladder accumulator is the actual bladder, and all Greer bladders are engineered and manufactured in our own facility and subjected to our own high quality inspection standards.

**Specifications**

**Materials**

- Shell – high strength alloy steel (SA372, all sizes comply with ASME material specifications, 1 gal. & larger supplied with ASME Certification as standard)
- Ports – all oil service ports, high strength alloy steel
  - water & chemical service:
    - 3000 PSI, 304 stainless steel
    - 5000 PSI, 17-4 PH stainless steel
- Poppet & Spring – 304 stainless steel
- Gas Valve Cartridge – steel
- Gas Valve Protector – steel
- Gas Valve Stem – steel
- Bladders – various elastomers, see Standard and Optional Bladders in this section.

**Maximum Flow Rates**

Size (gallon)	Max. Recommended Flow for Standard Mineral Oils	
	GPM	LPM
10 cu in	23	87
1 pt & 1 qt	40	151
150 cu in	60	227
1	150	568
2 1/2 thru 15	220	833
2 1/2 thru 15, High-flow	600	2271

**Pressure Ratings** – 3000 and 5000 PSI bladder accumulators are rated at minimum 4 to 1 design factors as standard. 4000 and 6600 PSI (ASME Appendix 22) bladder accumulators are available as an option at minimum 3 to 1 design factors. For pressures over 6600 PSI, consult the factory.

**Max. Recommended Compression Ratio** (max. working pressure/precharge pressure): 4 to 1.

**Certifications** – ASME Certification (Section VIII-Div. 1) is available as standard on bladder accumulators (1 gallon & up) and ASME Appendix 22 Certification as an option. See page 6 for a complete certification summary.

Size	Std. ASME Cert.			ASME Appendix 22	
	Status	Rating	D.F.*	Rating	D.F.*
10 thru 150 in <sup>3</sup> 3000 PSI	Option	3000 PSI	4 to 1	Consult Factory	
1 thru 15 gal. 3000 PSI	Std.	3000 PSI	4 to 1	4000 PSI	3 to 1
1 thru 15 gal. 5000 PSI	Std.	5000 PSI	4 to 1	6600 PSI	3 to 1

\*Design Factor.

**Fluids** – Greer bladder accumulators are compatible with a wide variety of fluids. The standard accumulator may be used with petroleum-based industrial or water-based flame resistant fluids. Bladders compatible with most industrial fluids can be furnished on special orders with temperature ranges from -40°F to 250°F (-40°C to 121°C).

**Precharge** – Units are shipped with a nominal nitrogen precharge as standard. For specific precharge pressures, specify at the time of order.

**Available Options** – a wide variety of options are available on Greer bladder accumulators including:

- Bladder Compounds (see Standard and Optional Bladders in this section).
- Ports (see Options in this section)
- Water & Chemical Service (see Options in this section)
- Gas Valves (see Options in this section)
- Fuse Plugs Assemblies (see Options in this section)
- Fixed Gauge Adapters (see Accumulator Accessories)



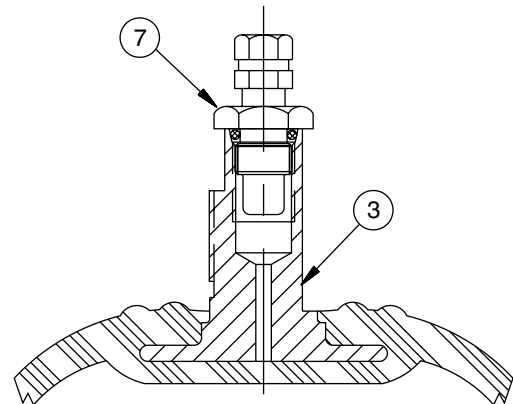
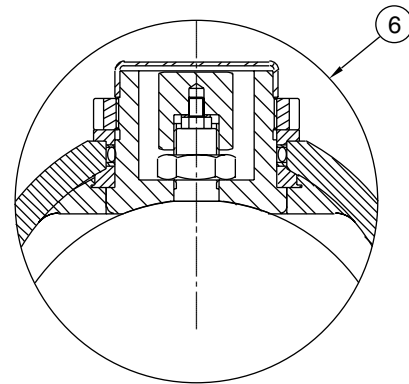
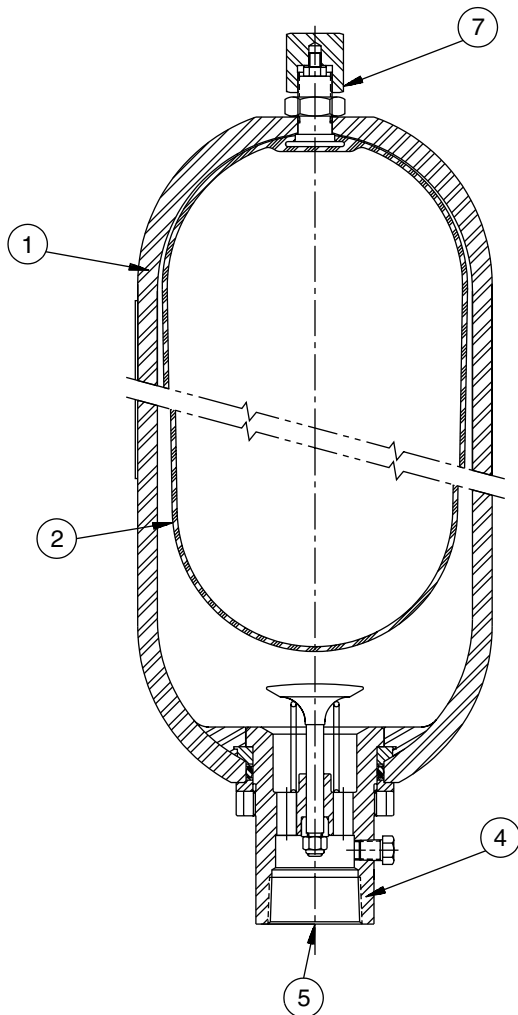

**Bladder**

### 1 Shell

Bladder accumulator shells are made from chrome-molybdenum alloy steel (SA372) with forged ends. All sizes comply with ASME material and design specifications. One gallon and larger supplied with ASME Certification as standard.

### 2 Bladder

Greer bladders, the heart and soul of a bladder accumulator, are manufactured in-house to control the material blending, molding, critical seam assembly, and curing processes. It is widely accepted that Greer bladders are the highest quality bladders in the industry. Bladders are offered in five different standard compounds to suit a wide variety of fluids and operating temperatures. Special compounds are available for unusual or severe applications.

### 3 Bladder Stems

All bladder accumulators, sizes 1 gallon and larger, are fitted as standard with two-piece bladder stems with replaceable gas valve cartridge for ease of serviceability. Also, the two-piece stem will accept high-flow poppet type gas valves and permanent mount gauge adapters.

### 4 Port Assemblies

Standard oil service ports are made from high-strength alloy steel for maximum durability. Chemical and water service port assemblies are made from stainless steel for maximum corrosion resistance.

### 5 Fluid Ports

SAE straight thread, NPTF, SAE Code 61 and SAE Code 62 4-bolt split flange, and High-flow ports are available (See page 60 for details). Bleed ports are included as standard on sizes 1 gallon and larger; not available on flange ports.

### 6 Top Repairable

The top repairable design permits easy checking and maintenance of the bladder without removing the accumulator from the system, saving time and money.

### 7 Gas Valve

All accumulators are fitted with a gas valve for ease of gas precharging. One-gallon and larger 3000 PSI units are equipped with a cored gas valve cartridge (ISO-4570-8V1) for ease of maintenance. 5000 PSI units are equipped with a high-pressure cored gas valve cartridge (ISO-4570-8V1) with an option of a high-flow poppet gas valve cartridge (L07689000K). For safety, the gas valve vents if unscrewed.

The simplicity and cost effectiveness of the bottom repairable design has made it the "Industry Standard" bladder accumulator. Sizes range from 10 cu in to 15 gallons.

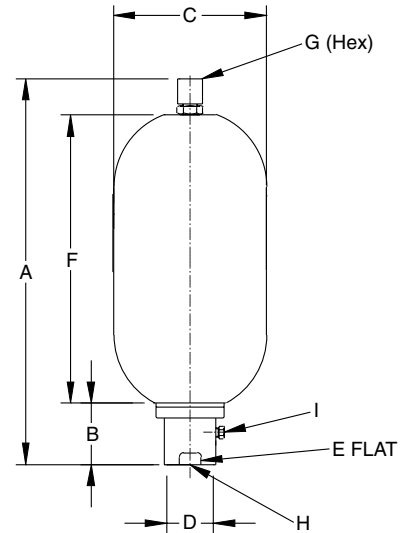

**3000 PSI (207 Bar)<sup>1</sup>**

Models Oil Service Water Service	Nominal Size Gallon (Liters)	Gas Volume cu in (Liters)	Dimensions, inch (mm)							Hydraulic Ports		Weight lbs. (Kg.)
			A	B	C	D	E	F	G	H (Thread)	I (Thread)	
BAC10B3T01A1 BAC10B3T01WA1	10 cu in (0.16)	12 (0.21)	11.18 (284)	1.89 (48)	2.00 (51)	1.03 (26)	0.94 (24)	7.75 (197)	0.94 (24)	SAE#8 (3/4 - 16)	N/A	3.5 (1.6)
BA001B3T01A1 BA001B3T01WA1	1 Pt. (0.47)	31 (0.51)	10.75 (273)	2.00 (51)	3.40 (86)	1.39 (35)	1.31 (33)	6.87 (174)	0.94 (24)	SAE #12 (1-1/16 -12)	N/A	8 (3.6)
BA002B3T01A1 BA002B3T01WA1	1 Qt. (0.95)	66 (1.08)	11.12 (282)	2.00 (51)	4.50 (114)	1.62 (41)	1.50 (38)	7.63 (194)	0.94 (24)	SAE #12 (1-1/16 -12)	N/A	10 (4.5)
BA005B3T01A1 BA005B3T01WA1	150 cu in (2.5)	156 (2.56)	19.56 (497)	2.08 (53)	4.50 (114)	1.62 (41)	1.50 (38)	15.50 (394)	0.94 (24)	SAE #16 (1-5/16 -12)	N/A	20 (9.1)
BA01B3T01A1 BA01B3T01WA1	1 (3.79)	231 (3.79)	17.00 (432)	3.50 (89)	6.75 (171)	2.37 (60)	2.13 (54)	11.36 (289)	1.25 (32)	SAE #20 (1-5/8 - 12)	SAE #6 (9/16 - 18)	34 (15)
BA02B3T01A1 BA02B3T01WA1	2.5 (9.46)	556 (9.11)	21.38 (543)	3.62 (92)	9.06 (230)	3.00 (76)	2.88 (73)	15.50 (394)	1.25 (32)	SAE #24 (1-7/8 - 12)	SAE #6 (9/16 - 18)	80 (36)
BA05B3T01A1 BA05B3T01WA1	5 (18.9)	1124 (18.42)	33.38 (848)	3.62 (92)	9.06 (230)	3.00 (76)	2.88 (73)	27.50 (700)	1.25 (32)	SAE #24 (1-7/8 - 12)	SAE #6 (9/16 - 18)	120 (55)
BA10B3T01A1 BA10B3T01WA1	10 (37.9)	2097 (34.36)	54.38 (1382)	3.62 (92)	9.06 (230)	3.00 (76)	2.88 (73)	48.50 (1231)	1.25 (32)	SAE #24 (1-7/8 - 12)	SAE #6 (9/16 - 18)	220 (100)
BA11B3T01A1 BA11B3T01WA1	11 (41.6)	2400 (39.33)	59.88 (1520)	3.62 (92)	9.06 (230)	3.00 (76)	2.88 (73)	54.00 (1371)	1.25 (32)	SAE #24 (1-7/8 - 12)	SAE #6 (9/16 - 18)	240 (109)
BA15B3T01A1 BA15B3T01WA1	15 (56.8)	3267 (53.54)	77.88 (1978)	3.62 (92)	9.06 (230)	3.00 (76)	2.88 (73)	72.00 (1830)	1.25 (32)	SAE #24 (1-7/8 - 12)	SAE #6 (9/16 - 18)	305 (139)

**1) Note:** 1 thru 15 gallon sizes available with 4000 PSI (275 Bar) Appendix 22 Approval.

**5000 PSI (345 Bar)<sup>2</sup>**

Models Oil Service Water Service	Nominal Size Gallon (Liters)	Gas Volume cu in (Liters)	Dimensions, inch (mm)							Hydraulic Ports		Weight lbs. (Kg.)
			A	B	C	D	E	F	G	H (Thread)	I (Thread)	
BA01B5T01A1 BA01B5T01WA1	1 (3.79)	231 (3.79)	17.25 (438)	3.25 (83)	7.14 (181)	2.25 (57)	N/A	11.44 (291)	1.44 (37)	SAE #20 (1-5/8 - 12)	SAE #6 (9/16 - 18)	50 (23)
BA02B5T01A1 BA02B5T01WA1	2.5 (9.46)	556 (9.11)	22.55 (573)	3.88 (99)	9.63 (245)	3.00 (76)	2.88 (73)	16.12 (409)	2.50 (64)	SAE #24 (1-7/8 - 12)	SAE #6 (9/16 - 18)	120 (55)
BA05B5T01A1 BA05B5T01WA1	5 (18.9)	1124 (18.42)	34.80 (884)	3.88 (99)	9.63 (245)	3.00 (76)	2.88 (73)	28.36 (720)	2.50 (64)	SAE #24 (1-7/8 - 12)	SAE #6 (9/16 - 18)	200 (91)
BA10B5T01A1 BA10B5T01WA1	10 (37.9)	2097 (34.36)	55.30 (1405)	3.88 (99)	9.63 (245)	3.00 (76)	2.88 (73)	48.88 (1242)	2.50 (64)	SAE #24 (1-7/8 - 12)	SAE #6 (9/16 - 18)	335 (152)
BA15B5T01A1 BA15B5T01WA1	15 (56.8)	3267 (53.54)	76.80 (1951)	3.88 (99)	9.63 (245)	3.00 (76)	2.88 (73)	70.38 (1788)	2.50 (64)	SAE #24 (1-7/8 - 12)	SAE #6 (9/16 - 18)	485 (220)

**2) Note:** Available with 6600 PSI (455 Bar) Appendix 22 Approval.



The Top Repairable Accumulator permits easy checking and maintenance of the bladder without removing the accumulator from the service line, saving time and money. Sizes range from 2-1/2 to 15 gallons.

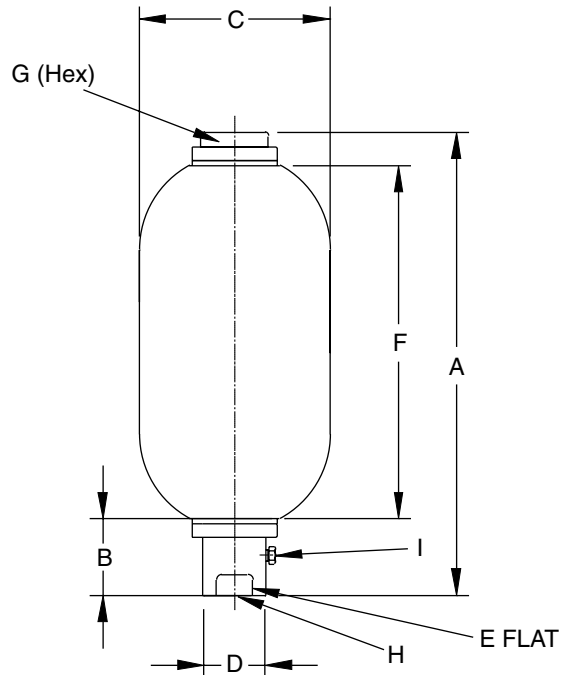

Bladder

**3000 PSI (207 Bar)<sup>1</sup>**

Models Oil Service Water Service	Nominal Size Gallon (Liters)	Gas Volume cu in (Liters)	Dimensions, inch (mm)							Hydraulic Ports		Weight lbs. (Kg.)
			A	B	C	D	E	F	G	H (Thread)	I (Thread)	
BA02T3T01A1 BA02T3T01WA1	2.5 (9.45)	541 (8.87)	20.50 (521)	3.62 (92)	9.06 (230)	3.00 (76)	2.88 (73)	15.38 (391)	1.25 (32)	SAE #24 (1-7/8 - 12)	SAE #6 (9/16 - 18)	80 (36)
BA05T3T01A1 BA05T3T01WA1	5 (18.9)	1110 (18.19)	32.75 (832)	3.62 (92)	9.06 (230)	3.00 (76)	2.88 (73)	27.63 (702)	1.25 (32)	SAE #24 (1-7/8 - 12)	SAE #6 (9/16 - 18)	120 (55)
BA10T3T01A1 BA10T3T01WA1	10 (37.8)	2083 (34.13)	53.25 (1353)	3.62 (92)	9.06 (230)	3.00 (76)	2.88 (73)	48.13 (1223)	1.25 (32)	SAE #24 (1-7/8 - 12)	SAE #6 (9/16 - 18)	220 (100)
BA11T3T01A1 BA11T3T01WA1	11 (41.6)	2386 (39.1)	59.00 (1499)	3.62 (92)	9.06 (230)	3.00 (76)	2.88 (73)	53.88 (1369)	1.25 (32)	SAE #24 (1-7/8 - 12)	SAE #6 (9/16 - 18)	240 (109)
BA15T3T01A1 BA15T3T01WA1	15 (56.7)	3253 (53.31)	77.38 (1965)	3.62 (92)	9.06 (230)	3.00 (76)	2.88 (73)	71.75 (1822)	1.25 (32)	SAE #24 (1-7/8 - 12)	SAE #6 (9/16 - 18)	305 (139)

**1) Note:** Available with 4000 PSI (275 Bar) Appendix 22

**5000 PSI (345 Bar)<sup>2</sup>**

Models Oil Service Water Service	Nominal Size Gallon (Liters)	Gas Volume cu in (Liters)	Dimensions, inch (mm)							Hydraulic Ports		Weight lbs. (Kg.)
			A	B	C	D	E	F	G	H (Thread)	I (Thread)	
BA02T5T01A1 BA02T5T01WA1	2.5 (9.46)	541 (8.87)	21.68 (551)	3.88 (99)	9.63 (245)	3.00 (76)	2.88 (73)	15.88 (403)	1.25 (32)	SAE #24 (1-7/8 - 12)	SAE #6 (9/16 - 18)	120 (55)
BA05T5T01A1 BA05T5T01WA1	5 (18.9)	1110 (18.19)	33.92 (862)	3.88 (99)	9.63 (245)	3.00 (76)	2.88 (73)	23.13 (715)	1.25 (32)	SAE #24 (1-7/8 - 12)	SAE #6 (9/16 - 18)	220 (100)
BA10T5T01A1 BA10T5T01WA1	10 (37.8)	2083 (34.13)	54.42 (1382)	3.88 (99)	9.63 (245)	3.00 (76)	2.88 (73)	48.63 (1235)	1.25 (32)	SAE #24 (1-7/8 - 12)	SAE #6 (9/16 - 18)	335 (152)
BA15T5T01A1 BA15T5T01WA1	15 (56.8)	3253 (53.31)	75.92 (1928)	3.88 (99)	9.63 (245)	3.00 (76)	2.88 (73)	70.13 (1781)	1.25 (32)	SAE #24 (1-7/8 - 12)	SAE #6 (9/16 - 18)	485 (220)

**2) Note:** Available with 6600 PSI (455 Bar) Appendix 22

For systems requiring a fast “dumping” rate, the High-flow accumulator incorporates a large port assembly capable of flows up to 600 GPM (2270 LPM). Sizes range from 2-1/2 to 15 gallons.

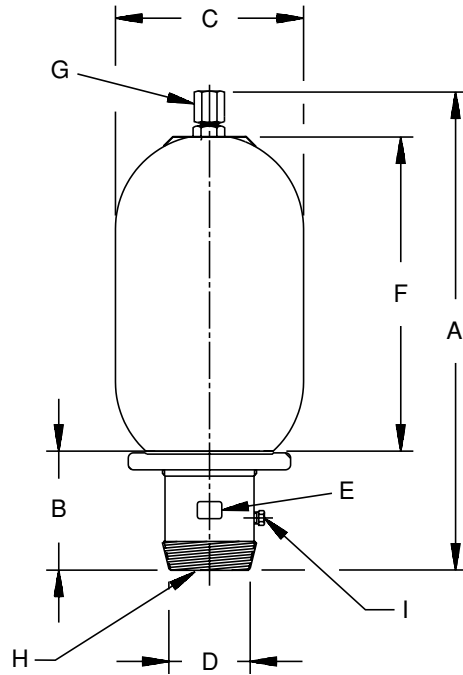

**3000 PSI (207 Bar)**

Models Male Str. Thd Male NPT	Nominal Size Gallon (Liters)	Gas Volume cu in (Liters)	Dimensions, inch (mm)							H Hydraulic Port	Port I (Thread)	Weight lbs. (Kg.)
			A	B	C	D	E	F	G			
BA02B3A01A1 BA02B3H01A1	2.5 (9.46)	556 (9.11)	22.88 (581)	5.62 (143)	9.06 (230)	4.00 (102)	3.85 (98)	15.25 (387)	1.25 (32)	4-1/4"-8 Str. Thd. 4 NPTF	SAE #6 (9/16-18)	90 (41)
BA05B3A01A1 BA05B3H01A1	5 (18.9)	1124 (18.42)	35.12 (892)	5.62 (143)	9.06 (230)	4.00 (102)	3.85 (98)	27.50 (699)	1.25 (32)	4-1/4"-8 Str. Thd. 4 NPTF	SAE #6 (9/16-18)	130 (59)
BA10B3A01A1 BA10B3H01A1	10 (37.9)	2097 (34.36)	55.62 (1413)	5.62 (143)	9.06 (230)	4.00 (102)	3.85 (98)	48.00 (1219)	1.25 (32)	4-1/4"-8 Str. Thd. 4 NPTF	SAE #6 (9/16-18)	230 (105)
BA11B3A01A1 BA11B3H01A1	11 (41.6)	2400 (39.33)	61.38 (1559)	5.62 (143)	9.06 (230)	4.00 (102)	3.85 (98)	53.75 (1365)	1.25 (32)	4-1/4"-8 Str. Thd. 4 NPTF	SAE #6 (9/16-18)	250 (114)
BA15B3A01A1 BA15B3H01A1	15 (56.8)	3267 (53.54)	79.62 (2022)	5.62 (143)	9.06 (230)	4.00 (102)	3.85 (98)	69.50 (1765)	1.25 (32)	4-1/4"-8 Str. Thd. 4 NPTF	SAE #6 (9/16-18)	315 (143)

**NOTE:** High-flow bladder accumulators not available with Appendix 22 option.

**Optional Flange Port**

For Model “A”  
 Hydraulic Port only

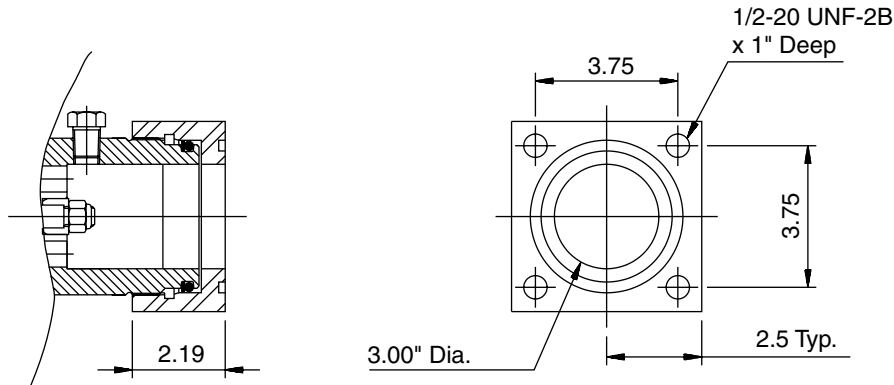

**Note:** Accumulator assembly does not include flange (part number 1467990000).



The Transfer Barrier accumulator provides positive separation between two different medias or can be used with gas bottles. Sizes range from 2-1/2 to 15 gallons.

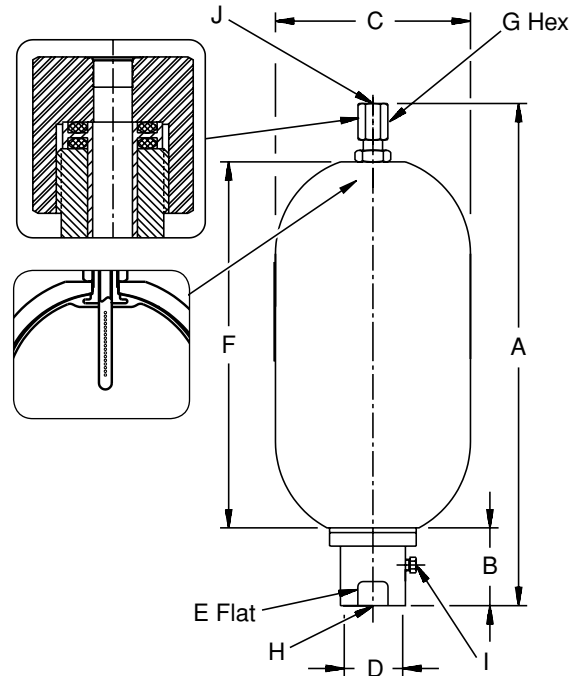

Bladder

**3000 PSI (207 Bar)<sup>1</sup>**

Models Oil Service Water Service	Nominal Size Gallon (Liters)	Gas Volume cu in (Liters)	Dimensions, inch (mm)							Hydraulic Ports			Weight lbs. (Kg.)
			A	B	C	D	E	F	G	H (Thread)	I (Thread)	J (Thread)	
BT02B3TT01A1 BT02B3TT01WA1	2.5 (9.45)	556 (9.11)	21.25 (540)	3.62 (92)	9.06 (230)	3.00 (76)	2.88 (73)	15.62 (397)	2.00 (51)	SAE #24 (1-7/8 - 12)	SAE #6 (9/16 - 18)	SAE #12 (1-1/16 -12)	80 (36)
BT05B3TT01A1 BT05B3TT01WA1	5 (18.9)	1124 (18.42)	33.50 (851)	3.62 (92)	9.06 (230)	3.00 (76)	2.88 (73)	27.88 (708)	2.00 (51)	SAE #24 (1-7/8 - 12)	SAE #6 (9/16 - 18)	SAE #12 (1-1/16 -12)	120 (55)
BT10B3TT01A1 BT10B3TT01WA1	10 (37.8)	2097 (34.36)	54.00 (1372)	3.62 (92)	9.06 (230)	3.00 (76)	2.88 (73)	48.50 (1231)	2.00 (51)	SAE #24 (1-7/8 - 12)	SAE #6 (9/16 - 18)	SAE #12 (1-1/16 -12)	220 (100)
BT11B3TT01A1 BT11B3TT01WA1	11 (41.6)	2400 (39.33)	59.75 (1518)	3.62 (92)	9.06 (230)	3.00 (76)	2.88 (73)	54.12 (1375)	2.00 (51)	SAE #24 (1-7/8 - 12)	SAE #6 (9/16 - 18)	SAE #12 (1-1/16 -12)	240 (109)
BT15B3TT01A1 BT15B3TT01WA1	15 (56.7)	3267 (53.54)	77.62 (1972)	3.62 (92)	9.06 (230)	3.00 (76)	2.88 (73)	72.00 (1829)	2.00 (51)	SAE #24 (1-7/8 - 12)	SAE #6 (9/16 - 18)	SAE #12 (1-1/16 -12)	305 (139)

<sup>1</sup> Note: Available with 4000 PSI (275 Bar) Appendix 22

**5000 PSI (345 Bar)<sup>2</sup>**

Models Oil Service Water Service	Nominal Size Gallon (Liters)	Gas Volume cu in (Liters)	Dimensions, inch (mm)							Hydraulic Ports			Weight lbs. (Kg.)
			A	B	C	D	E	F	G	H (Thread)	I (Thread)	J (Thread)	
BT02B5TT01A1 BT02B5TT01WA1	2.5 (9.45)	556 (9.11)	22.55 (573)	3.62 (92)	9.63 (245)	3.00 (76)	2.88 (73)	16.12 (409)	2.00 (51)	SAE #24 (1-7/8 - 12)	SAE #6 (9/16 - 18)	SAE #12 (1-1/16 -12)	120 (55)
BT05B5TT01A1 BT05B5TT01WA1	5 (18.9)	1124 (18.42)	34.80 (884)	3.62 (92)	9.63 (245)	3.00 (76)	2.88 (73)	28.36 (720)	2.00 (51)	SAE #24 (1-7/8 - 12)	SAE #6 (9/16 - 18)	SAE #12 (1-1/16 -12)	200 (91)
BT10B5TT01A1 BT10B5TT01WA1	10 (37.8)	2097 (34.36)	55.30 (1405)	3.62 (92)	9.63 (245)	3.00 (76)	2.88 (73)	48.88 (1242)	2.00 (51)	SAE #24 (1-7/8 - 12)	SAE #6 (9/16 - 18)	SAE #12 (1-1/16 -12)	335 (152)
BT15B5TT01A1 BT15B5TT01WA1	15 (56.7)	3267 (53.54)	76.80 (1951)	3.62 (92)	9.63 (245)	3.00 (76)	2.88 (73)	70.38 (1788)	2.00 (51)	SAE #24 (1-7/8 - 12)	SAE #6 (9/16 - 18)	SAE #12 (1-1/16 -12)	485 (220)

<sup>2</sup> Note: Available with 6600 PSI (455 Bar) Appendix 22

Where space does not permit the installation of the required accumulator, a smaller accumulator may be used by connecting it to an auxiliary gas bottle(s) that may be located in some nearby spot where space is available. (See Large Gas Bottles for additional offerings and page 84 for sizing information.) Sizes range from 1 to 15 gallons.

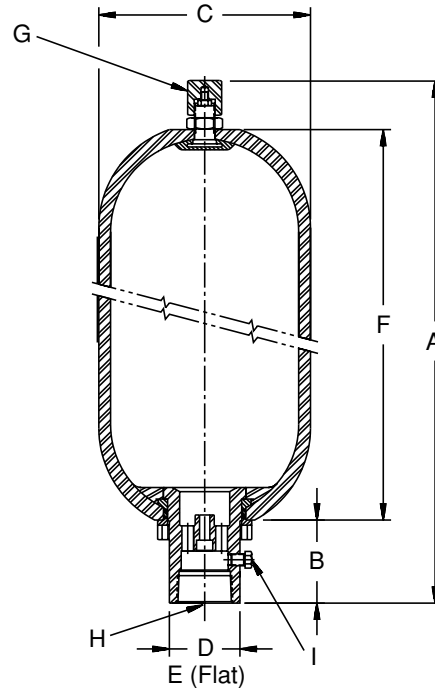
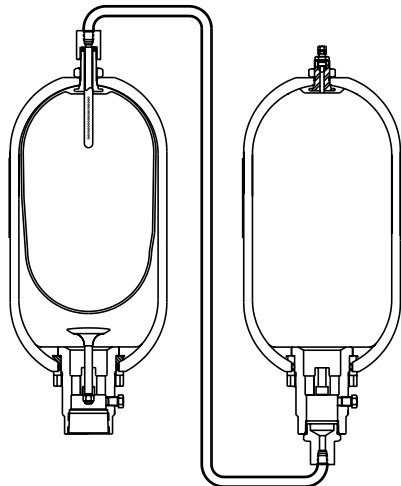

**3000 PSI (207 Bar)<sup>1</sup>**

Models	Nominal Size Gallon (Liters)	Dimensions, inch (mm)							Ports		Weight lbs. (Kg.)
		A	B	C	D	E	F	G	H (Thread)	I (Thread)	
BG01B3T01A1	1 (3.79)	17.00 (432)	3.50 (89)	6.75 (171)	2.37 (60)	2.13 (54)	11.36 (289)	1.25 (32)	SAE #20 (1-5/8 - 12)	SAE #6 (9/16 - 18)	34 (15)
BG02B3T01A1	2.5 (9.46)	21.25 (540)	3.62 (92)	9.06 (230)	3.00 (76)	2.88 (73)	15.62 (397)	1.25 (32)	SAE #24 (1-7/8 - 12)	SAE #6 (9/16 - 18)	80 (36)
BG05B3T01A1	5 (18.9)	33.50 (851)	3.62 (92)	9.06 (230)	3.00 (76)	2.88 (73)	27.88 (708)	1.25 (32)	SAE #24 (1-7/8 - 12)	SAE #6 (9/16 - 18)	120 (55)
BG10B3T01A1	10 (37.9)	54.00 (1372)	3.62 (92)	9.06 (230)	3.00 (76)	2.88 (73)	43.38 (1102)	1.25 (32)	SAE #24 (1-7/8 - 12)	SAE #6 (9/16 - 18)	220 (100)
BG11B3T01A1	11 (41.6)	59.75 (1518)	3.62 (92)	9.06 (230)	3.00 (76)	2.88 (73)	54.12 (1375)	1.25 (32)	SAE #24 (1-7/8 - 12)	SAE #6 (9/16 - 18)	240 (109)
BG15B3T01A1	15 (56.8)	77.62 (1972)	3.62 (92)	9.06 (230)	3.00 (76)	2.88 (73)	72.00 (1829)	1.25 (32)	SAE #24 (1-7/8 - 12)	SAE #6 (9/16 - 18)	305 (139)

1) Note: Available with 4000 PSI (275 Bar) Appendix 22

**5000 PSI (345 Bar)<sup>2</sup>**

Models	Nominal Size Gallon (Liters)	Dimensions, inch (mm)							Ports		Weight lbs. (Kg.)
		A	B	C	D	E	F	G	H (Thread)	I (Thread)	
BG01B5T1A1	1 (3.79)	17.25 (438)	3.25 (83)	7.14 (181)	2.25 (57)	N/A	11.44 (291)	1.44 (37)	SAE #20 (1-5/8 - 12)	SAE #6 (9/16 - 18)	50 (23)
BG02B5T1A1	2.5 (9.46)	22.55 (573)	3.88 (99)	9.63 (245)	3.00 (76)	2.88 (73)	16.12 (409)	2.50 (64)	SAE #24 (1-7/8 - 12)	SAE #6 (9/16 - 18)	120 (55)
BG05B5T1A1	5 (18.9)	34.80 (884)	3.88 (99)	9.63 (245)	3.00 (76)	2.88 (73)	28.36 (720)	2.50 (64)	SAE #24 (1-7/8 - 12)	SAE #6 (9/16 - 18)	200 (91)
BG10B5T1A1	10 (37.9)	55.30 (1405)	3.88 (99)	9.63 (245)	3.00 (76)	2.88 (73)	48.88 (1242)	2.50 (64)	SAE #24 (1-7/8 - 12)	SAE #6 (9/16 - 18)	335 (152)
BG15B5T1A1	15 (56.8)	76.80 (1951)	3.88 (99)	9.63 (245)	3.00 (76)	2.88 (73)	70.38 (1788)	2.50 (64)	SAE #24 (1-7/8 - 12)	SAE #6 (9/16 - 18)	485 (220)

2) Note: Available with 6600 PSI (455 Bar) Appendix 22



### Standard and Optional Bladders

A variety of bladders are offered to suit a wide range of fluids and operating temperatures. The following table lists the optional bladders available, their recommended operating temperature ranges, and the types of fluids that are generally compatible.

Seal Code	Polymer	**Recommended Operating Temperature Range	Maximum Temperature with Reduced Life	General Application & Compatibility*
01	Buna-Nitrile	-20°F to 200°F -29°C to 93°C	225°F 107°C	Standard Compound – Compatible with most mineral oil-based fluids
04	Hydrin (Lo-Temp.)	-40°F to 225°F -40°C to 107°C	250°F 121°C	Compatible with most mineral oil-based fluids with enhanced low temperature performance
06	Butyl	-40°F to 200°F -40°C to 93°C	300°F 149°C	Compatible with most phosphate ester fluids and some synthetic fluids
08	Ethylene Propylene	-40°F to 200°F -40°C to 93°C	300°F 149°C	Compatible with some synthetic fluids and water
28	Fluorocarbon Elastomer	-10°F to 250°F -23°C to 121°C	400°F 204°C	Compatible with most mineral oil-based fluids at higher temperatures and some exotic fluids

\* Consult your local distributor or the factory for fluid compatibility information.  
\*\* Temperature ranges may vary depending upon the fluid used in the hydraulic system.

### Water & Chemical Service Options (W)

Bladder accumulators are available with a water and chemical resistance option. The (W) designation includes an internally Scotchkoted shell and stainless steel or electroless nickel plated port assembly. The Scotchkote offers added protection against more corrosive fluids.

### Gas Valves

Two types of gas valves are available on bladder accumulators. 3000 PSI rated models are offered with a cored gas valve cartridge (cartridge type, 1 gal. & up, ISO-4570-8V1) as standard. 5000 PSI units are equipped with a high-pressure cored gas valve cartridge (ISO-4570-8V1) with an option of a heavy-duty poppet type gas valve cartridge (L07689000K).

A high-flow poppet style gas valve is available upon request, but must be approved by a Parker accumulator engineer. Please contact the division for assistance.

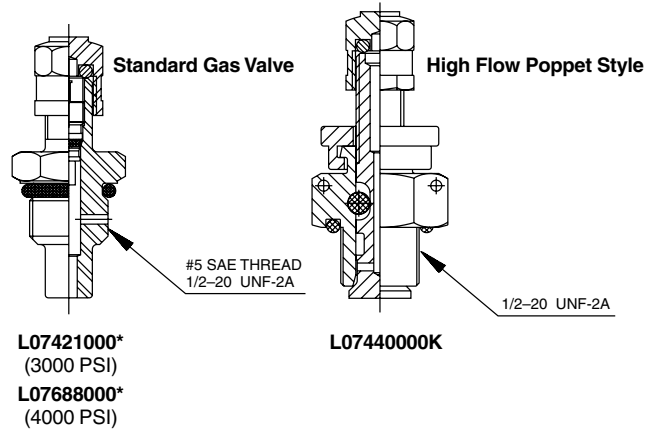

Bladder

Diaphragm

Inline Pulse-Tone™

Gas Bottles

**Standard and Optional Fluid Ports**

The following standard and optional fluid ports are offered on all Bottom Repairable, Top Repairable, and Transfer Barrier accumulators (for high-flow ports, see High-flow). See How to Order at the end of this section for complete ordering instructions.

Sizes	Standard Port	Optional Ports				
	SAE Str. Thread Code T	SAE 4-Bolt Split Flange* Code F	NPTF Code U	Undersize NPTF Code X	BSPP Code R	ISO 6149-1 Code Y
<b>3000 PSI (207 Bar) Models</b>						
10 cu in	SAE #8	–	3/4" Male	–	–	M 8x1.5
1 pt., 1 qt.	SAE #12	–	3/4"	–	G 3/4"	M 27x2
150 cu in	SAE #16	–	1"	–	G 1"	M 33x2
1 gal.	SAE #20	1-1/4", Code 61	1-1/4"	–	G 1-1/4"	M 42x2
2½ to 15 gal.	SAE #24	2", Code 61	2"	1-1/4"	G 2"	M 48x2
<b>5000 PSI (345 Bar) Models</b>						
1 gal.	SAE #20	1-1/4", Code 62	1-1/4"	–	G 1-1/4"	M 42x2
2½ to 15 gal.	SAE #24	1-1/2", Code 62	2"	–	G 2"	M 48x2

**SAE 4-Bolt Flange Port Dimensions**

Standard Pressure – Code 61 (ISO 6162) – 3000 PSI (207 Bar)

Flange Size	SAE Flange Dimensions (in.)					ISO 6162 Flange Dimensions (mm)				
	A	B	C	F	G	A	B	C	F	G
1-1/4"	7/16 - 4	1.188	2.312	1-1/2	1.000	M10	30.2	58.7	32	25.4
2"	1/2 - 13	1.688	3.062	2	1.062	M12	42.9	77.8	51	26.9

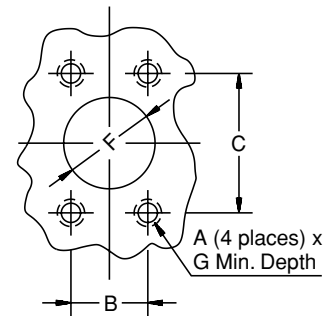

High Pressure – Code 62 (ISO 6162) – 6000 PSI (410 Bar)

Flange Size	SAE Flange Dimensions (in.)					ISO 6162 Flange Dimensions (mm)				
	A	B	C	F	G	A	B	C	F	G
1-1/4"	1/2 - 13	1.250	2.625	1-1/4	1.000	M16	31.8	66.7	32	25.4
1-1/2"	5/8 - 11	1.438	3.125	1-1/2	1.375	M16	36.5	79.4	38	34.9

**Note:** The dimensions shown on this chart are for the mating manifold. The flange halves are not supplied with the accumulator.

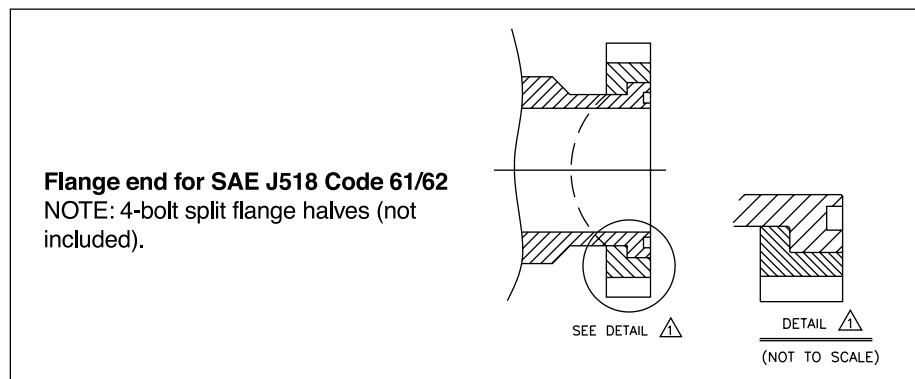

**Safety Fuse Options**

Safety Fuses are used as a safety device on accumulators and gas bottles to prevent over-pressurization of gas due to external heat or hydraulic pressure (set at 140% of maximum system pressure to avoid rupture disk fatigue and premature failure). The rupture disks are calibrated to rupture at a pre-determined pressure. Safety fuses are available on most sizes of piston and bladder accumulators and gas bottles. Safety fuses can be installed on 1 gallon & larger accumulators by using the "Fuse Adapter" as shown to the right. The safety fuse assembly and/or fuse adapter must be ordered separately.

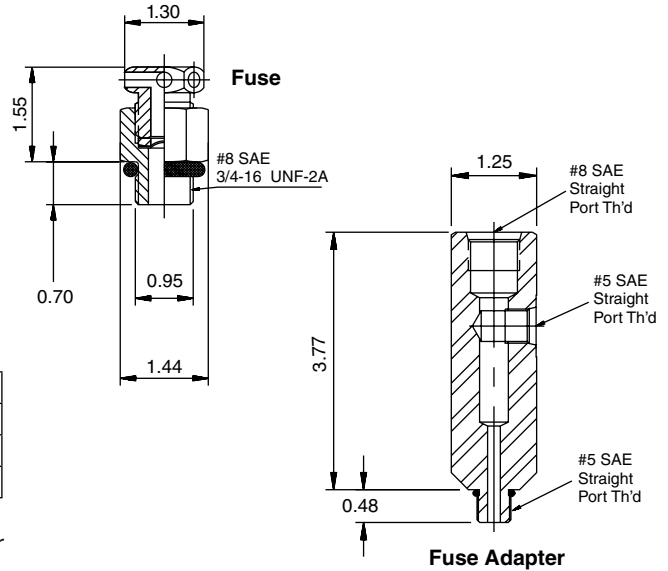

Description	Part Number
Safety Fuse Assembly <sup>1</sup>	086471xxxx
Replacement Rupture Disks	756003xxxx
Fuse Adapter	1468970002

<sup>1</sup> Assembly includes housing and rupture disk, xxxx = pressure setting in 100 PSI increments, i.e., for an assembly with a 2000 PSI setting, order P/N 0864712000.

**Note:** ASME and CRN units available upon request.

**Mounting, Charging & Gauging Accessories**

See Accessories page 97.

**Special Options**

If your application requires a bladder accumulator or special option that falls outside of our broad offering, consult your local distributor, Greer representative, or the factory with your specific requirements. We have the manufacturing and engineering expertise to design and build bladder accumulators to your exacting requirements, from simple modifications to standard units to complete designs from scratch. Some example of our past special designs include:

- Special and Stainless Steel Materials
- Special Bladder Compounds
- Suction Stabilizer
- Pulsation Dampener
- Special Certifications

**Consult our experts with your next bladder accumulator requirement!**



**Specifications & Dimensions**

There have been many attempts to solve the problems caused by high transient flow conditions inherent with pulsations and shocks. All attempts have had one thing in common: they never quite solved the problem. Then came Greer's Pulse-Tone concept, a patented breakthrough in pulsation control. The trouble with the previous devices was that most of the pulsations and shocks never got near the shock absorber. Pulse-Tone puts a flow diversion baffle into the line. Fluid traveling through the hydraulic line bends around the baffle, but pulsation and shock energy waves take the path of least resistance right into the nitrogen precharged bladder. The bladder absorbs up to 98% of the waves' potentially destructive force.

**Why Use Pulse-Tones?**

- improves system efficiency
- absorbs hydraulic shocks
- very contamination tolerant
- very quick response
- works well with water, low lubricity fluids

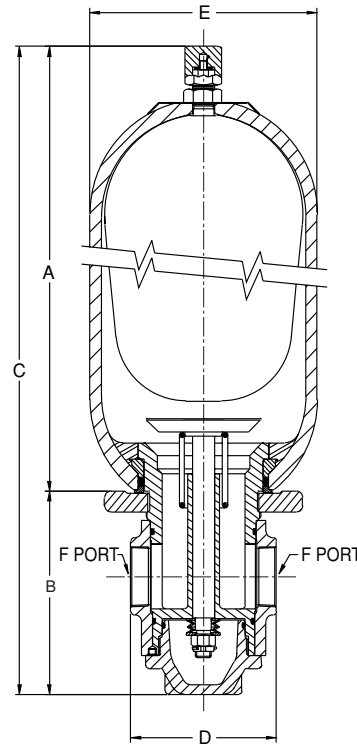

**Specifications**

**Maximum Operating Pressure** - 3000 PSI (207 Bar)

**Materials**

- Shell – high strength alloy steel (SA372, 1 gallon & up comply with all ASME material specifications as std.)
- Ports – all oil service ports, high strength alloy steel – water and chemical service, 3000 PSI, 304 stainless steel
- Poppet & Spring – 304 stainless steel
- Gas Valve Cartridge – steel
- Gas Valve Protector – steel
- Gas Valve Stem – steel
- Bladders – Various polymers, see Standard and Optional Bladders in Bladder Accumulators section.

**Maximum Compression Ratio** (max. working pressure/precharge pressure) 4-1

**Pulse-Tone Flow Rates**

Size (cu in)	Max. Recommended Flow	
	GPM	LPM
1 quart	28.0	106
1 gal.	38.0	145
2.5-15 gal.	190.0	720

**Models, Capacities & Dimensions**

Size	Bladder Material (Code)	Part No.	Repair Kit Part No.	Capacity cu in (liters)	A	B	C	D	E	F	Weight lbs. (kg.)
					in (mm)						
1 quart	Nitrile (-1)	834340	703040	60 (0.98)	7.38 (187)	3.03 (77)	12.16 (309)	2.00 (51)	4.50 (114)	1" NPTF	17 (7.7)
1 gal.	Nitrile (-1)	810381	703047	226 (3.70)	11.25 (286)	5.06 (129)	18.56 (471)	4.50 (114)	6.81 (173)	1-1/4" NPTF	46 (21)
2-1/2 gal.	Nitrile (-1)	810829	703054	555 (9.10)	15.50 (394)	8.50 (216)	26.23 (666)	6.75 (171)	9.00 (229)	2" NPTF	125 (57)
5 gal.	Nitrile (-1)	800290	703061	1095 (17.9)	27.94 (710)	8.50 (216)	38.69 (983)	6.75 (171)	9.00 (229)	2" NPTF	155 (70)



A full range of genuine Greer replacement bladder kits are available to bring your accumulator back to original condition should replacement become necessary. All bladder kits include port o-ring, backup seals and gas valves with secondary seals.

**NOTE:** Part numbers shaded in gray will be phased out.

Bladder & Seal Compound						
Size	Brand	Group 01 Nitrile (NBR)	Group 04 Hydrin	Group 06 Butyl	Group 08 EPR	Group 28 Fluorocarbon
<b>3,000 PSI Standard Bladder Kits (Top &amp; Bottom Repairable)</b>						
10 Cu. In.	Greer	702900	702902	702903	702904	702906
	Parker	0850693C10	0856663C10	0850703C10	0851053C10	0851043C10
1 Pt.	Greer	702914	702916	702917	702918	702920
	Parker	0850693001	0856663001	0850703001	0851053001	0851043001
1 Qt.	Greer	702928	702930	702931	702932	702934
	Parker	0850693002	0856663002	0850703002	0851053002	0851043002
150 Cu. In.	Greer	702942	702944	702945	702946	702948
	Parker	0850693006	0856663006	0850703006	0851053006	0851043006
1 Gal.	Greer	702956	702958	702959	702960	702962
	Parker	0850693010	0856663010	0850703010	0851053010	0851043010
2 1/2 Gal.	Greer	702970	702972	702973	702974	702976
	Parker	0850693025	0856663025	0850703025	0851053025	0851043025
5 Gal.	Greer	702984	702986	702987	702988	702990
	Parker	0850693050	0856663050	0850703050	0851053050	0851043050
10 Gal.	Greer	702998	703000	703001	703002	703004
	Parker	0850693100	0856663100	0850703100	0851053100	0851043100
11 Gal.	Greer	703012	703014	703015	703016	703018
	Parker	0850693110	0856663110	0850703110	0851053110	0851043110
15 Gal.	Greer	703026	703028	703029	703030	703032
	Parker	0850693150	0856663150	0850703150	0851053150	0851043150
25 Gal.	Greer	703340	704008	704009	703341	703342
	Parker	0850693250	0856663250	0850703250	0851053250	0851043250
40 Gal.	Greer	703346	704014	704015	703347	703348
	Parker	0850693400	0856663400	0850703400	0851053400	0851043400
<b>5,000 PSI Bottom Repairable Bladder Kits (2" Valve Stem - New Style)</b>						
1 Gal. 7/8" ø Stem	Greer	8706135010	8706175010	8706145010	8706145010	8706155010
	Parker	8706135010	8706175010	8706145010	8706145010	8706155010
1 Gal. 1" ø Stem	Greer	704060	704062	704063	704064	704066
	Parker	0850695010	0856665010	080705010	0851055010	0851045010
2 1/2 Gal.	Greer	706000	706002	706003	706004	706006
	Parker	0861905025	0861945025	0861915025	0861935025	0861925025
5 Gal.	Greer	706010	706012	706013	706014	706016
	Parker	0861905050	0861945050	0861915050	0861935050	0861925050
10 Gal.	Greer	706020	706022	706023	706024	706026
	Parker	0861905100	0861945100	0861915100	0861935100	0861925100
15 Gal.	Greer	706030	706032	706033	706034	706036
	Parker	0861905150	0861945150	0861915150	0861935150	0861925150
<b>5,000 PSI Bottom Repairable Bladder Kits (7/8" Valve Stem - Old Style)</b>						
2 1/2 Gal.	Parker	0850695025	0856665025	0850705025	0851055025	0851045025
5 Gal.	Parker	0850695050	0856665050	0850705050	0851055050	0851045050
10 Gal.	Parker	0850695100	0856665100	0850705100	0851055100	0851045100
15 Gal.	Parker	0850695150	0856665150	0850705150	0851055150	0851045150

Bladder



**How to Order Bladder Accumulators**

Bladder accumulators and gas bottles can be specified by using the symbols in the chart below to develop a model number. Select only those symbols that represent the features desired, and place them in the sequence indicated by the example at the top of the chart.

**Series      Size      Construction      Gas Pressure      Hyd. Port<sup>1</sup>      Bladder/Seal Compound      Design Modification      Design Code**

**BA      001      B      3      T      01      -A      1**

**Series**

<b>BA</b>	Accumulator
<b>BG</b>	Gas Bottle
<b>BT</b>	Transfer Barrier

**Size**

Size	Available	
	3000 PSI	5000 PSI
<b>C10</b>	10 Cl	.
<b>001</b>	1 Pint	.
<b>002</b>	1 Quart	.
<b>005</b>	150 Cl	.
<b>01</b>	1 Gallon	.
<b>02</b>	2½ Gallon	.
<b>05</b>	5 Gallon	.
<b>10</b>	10 Gallon	.
<b>11</b>	11 Gallon	.
<b>15</b>	15 Gallon	.

**Construction**

Hydraulic Port		
<b>T</b>	<b>SAE Straight Thread O-Ring (Standard)</b>	
	10 Cl	SAE #8
	1 Pint & 1 Quart	SAE #12
	150 Cl	SAE #16
	1 Gallon	SAE #20
	2½ Gallon thru 15 Gallon	SAE #24
<b>U</b>	<b>NPT Pipe (No Cost Option)</b>	
	10 Cl	3/4" NPT Male
	1 Pint & 1 Quart	3/4" NPTF
	150 Cl	1" NPTF
	1 Gallon	1 1/4" NPTF
	2½ Gallon thru 15 Gallon	2" NPTF
<b>F</b>	<b>SAE 4-Bolt Split Flange (No Cost Option)</b>	
	10 Cl thru 150 Cl (3K)	N/A
	1 Gallon (3K)	1 1/4" Code 61 (3000 PSI)
	1 Gallon (5K)	1 1/4" Code 62 (6000 PSI)
	2½ Gal. thru 15 Gal. (3K)	2" Code 61 (3000 PSI)
	2½ Gal. thru 15 Gal. (4K)	1 1/2" Code 62 (6000 PSI)
	2½ Gal. thru 15 Gal. (5K)	1 1/2" Code 62 (6000 PSI)
<b>L</b>	<b>CE 2" Flange</b>	
<b>H</b>	<b>High Flow 4" NPT Male (Extra Cost Option)</b>	
	Available on 2½ Gallon thru 15 Gallon Sizes only (3000 PSI)	
<b>A</b>	<b>High Flow 4¼-8 UN-2 Straight Thread Male (Extra Cost Option)</b>	
	Available on 2½ Gallon thru 15 Gallon Sizes only (3000 PSI)	
<b>C</b>	<b>Medium Flow M95x2 Straight Thread Male (Extra Cost Option)</b>	
	Available on 2½ Gallon thru 15 Gallon Sizes only (3000 PSI)	
<b>X</b>	<b>NPT Pipe Undersized (No Cost Option)</b>	
	2½ Gallon thru 15 Gallon Sizes only (3000 PSI)	1-1/4" NPT
<b>R</b>	<b>BSPP</b>	
	10 Cl	N/A
	1 Pint & 1 Quart	3/4-14
	150 Cl	1-11
	1 Gallon	1 1/4-11
	2½ Gallon thru 15 Gallon	2-11
<b>Y</b>	<b>ISO 6149-1</b>	
	10 Cl	M18 x 1.5
	1 Pint & 1 Quart	M27 x 2
	150 Cl	M33 x 2
	1 Gallon	M42 x 2
	2½ Gallon thru 15 Gallon	M48 x 2
<b>G</b>	<b>Metric</b>	
	10 Cl	M18 x 1.5
	1 Pint & 1 Quart	M27 x 2
	150 Cl	M33 x 2
	1 Gallon	M42 x 2
	2½ Gallon thru 15 Gallon	M48 x 2
<b>S</b>	<b>Special</b>	

**Type of Construction**

<b>B</b>	Bottom Repairable Standard on all sizes
<b>T</b>	Top Repairable Optional for 2½ Gallon and up

**Working Pressure**

<b>3</b>	3,000 PSI (330 bar CE only)
<b>4</b>	4,000 PSI
<b>5</b>	5,000 PSI
<b>6</b>	6,600 PSI
<b>Y</b>	Special

**Design Code**

<b>1</b>	Standard
*	Number given

**Design Modification (1st Digit)**

<b>Blank</b>	Standard
<b>W</b>	Water/Chemical Service▲
<b>M</b>	Poppet Type L0789000K

**Design (2nd Digit)**

<b>A</b>	Standard ASME (1 Gallon & up)
<b>C</b>	SELO
<b>D</b>	ASME (< 1 Gallon)
<b>E</b>	CE Marking
<b>G</b>	Appendix 22 Shell
<b>S</b>	Special

▲ Consult factory when using water/chemical service with any port other than the standard SAE.

**Bladder/Seal Compound**

<b>01</b>	Buna-Nitrile (Std.)
<b>04</b>	Hydrin (Optional)
<b>06</b>	Butyl (Optional)
<b>08</b>	EPR (Optional)
<b>28</b>	Fluoroelastomer (Optional)

\* 1 Gal. through 15 gal. – A.S.M.E. design with "U" stamp.  
 1 Pt., 1 Qt. and 150 C.I. – A.S.M.E. design, available with "U" stamp.  
 If "U" stamp is required, it must be specified at time of order.  
 NOTE: A.S.M.E. documentation or any other certification must be requested at time of order.

