

Metric Hydraulic Cylinders

Series HMI

aerospace
climate control
electromechanical
filtration
fluid & gas handling
hydraulics
pneumatics
process control
sealing & shielding



ENGINEERING YOUR SUCCESS.

Parker Series HMI Metric Hydraulic Cylinders

As the world leader in the design and manufacture of tie-rod cylinders, Parker Cylinder Division introduces the Parker Series HMI *metric* hydraulic cylinder. Parker's HMI Series cylinders are designed to meet the requirements of ISO 6020/2 (1991), 160 Bar Compact Series. HMI Series cylinders may be used for working pressures up to 210 Bar.



Parker HMI Series cylinders are the true *world standard*, available all over the globe from Parker's worldwide manufacturing facilities. Whether you or your machine are in Europe, Asia, South America, Canada, Mexico, or the United States, you can rely on the engineering expertise, manufacturing experience, and commitment to quality that you've come to expect from the Parker Cylinder Division.

Series HMI Standard Features and Specifications

- ISO 6020/2 mounting interchangeable
- 12 standard mounting styles
- Up to 3 rod sizes per bore
- Wide range of mounting accessories
- Up to 3 male and 3 female rod end threads per bore
- Bore sizes – 25mm to 200mm
- Strokes – available in any practical stroke length
- Working pressure up to 210 bar
- Piston rods – 12mm to 140mm
- Single and Double rod designs
- Cushions available at either end
- Temperature Range – -20°C to 150°C depending on seal type
- Seal types to suit a wide variety of operating environments

In line with our policy of continuing product improvement, specifications in this catalog are subject to change.

Available Mountings and Where To Find Them

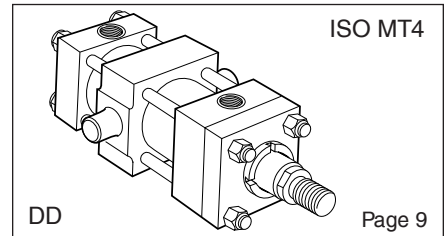
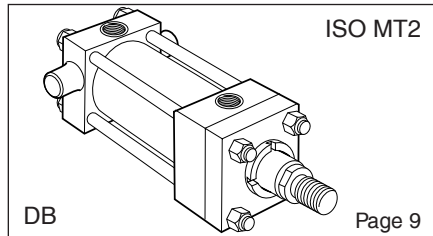
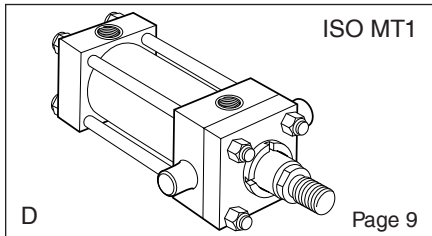
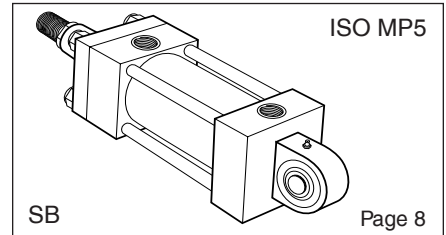
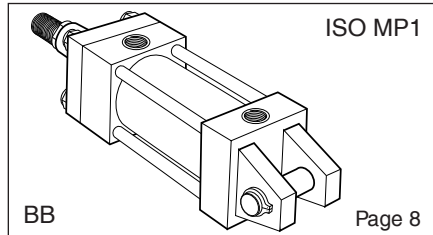
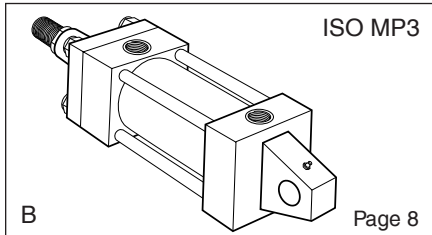
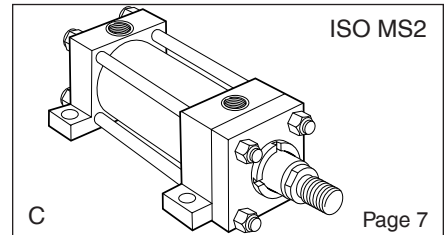
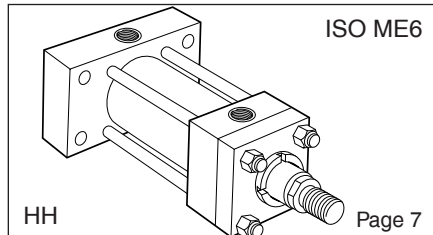
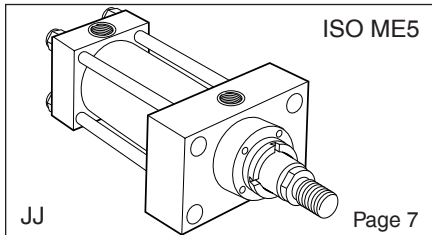
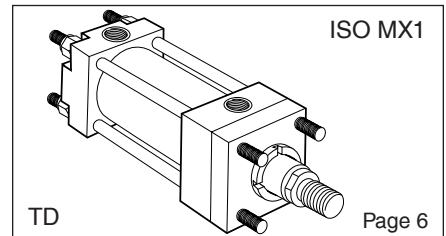
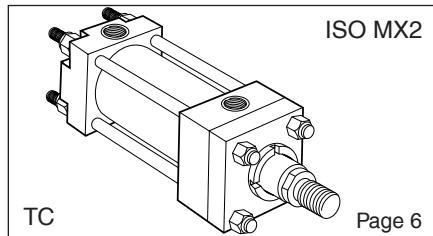
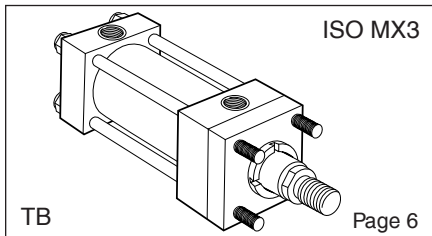

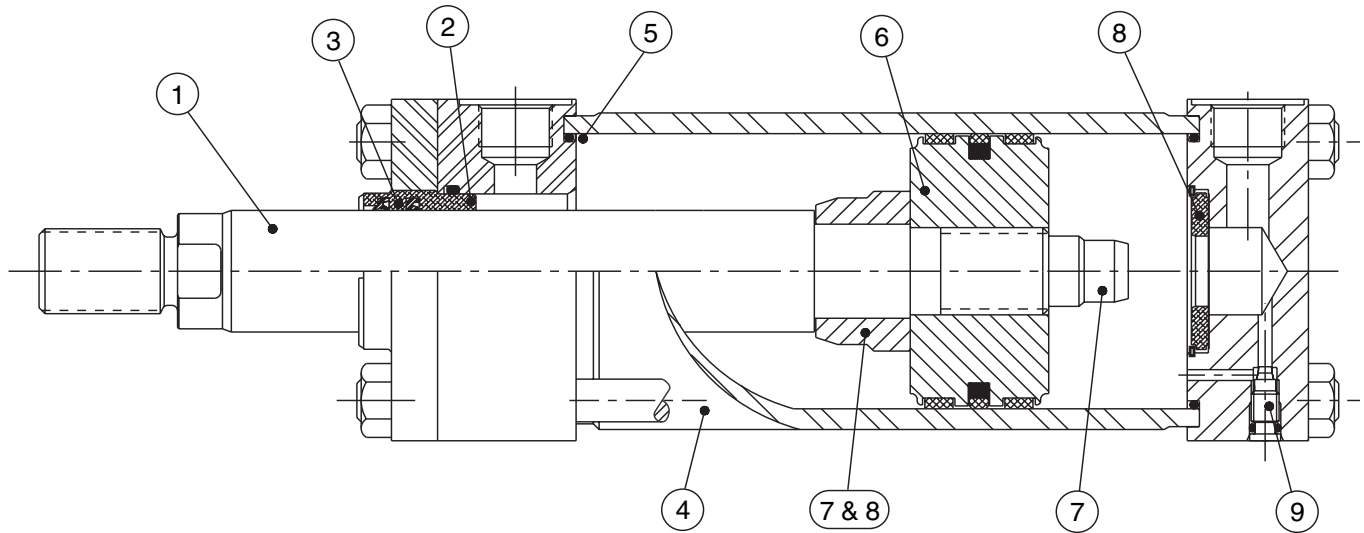

1 Piston Rod

Gland seal life is maximized by manufacturing piston rods from precision ground, high tensile carbon alloy steel, hard chrome plated and polished to 0.2µm max.

2 Parker's 'Jewel' Gland

Continuous lubrication, and therefore longer gland life, are provided by the long bearing surface inboard of the primary seal. The Jewel gland, complete with rod seals, can easily

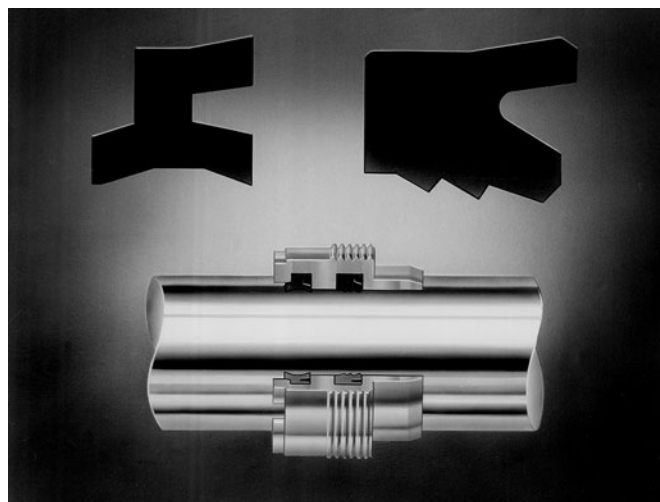

be removed without dismantling the cylinder, so servicing is quicker – and therefore more economical.

3 Rod Seals

The TS-2000 primary seal has a series of sealing edges which take over successively as pressure increases, providing efficient sealing under all operating conditions. On the return stroke the serrations act as a check valve, allowing the oil adhering to the rod to pass back into the cylinder.

The double lip wiperseal acts as a secondary seal, trapping excess lubricating film in the chamber between the wiper and

lip seals. Its outer lip prevents the ingress of dirt into the cylinder, extending the life of gland and seals.

The TS-2000 is manufactured from an enhanced polyurethane, giving efficient retention of pressurized fluid and long service life.

4 Cylinder Body

Strict quality control standards and precision manufacture ensure that all tubes meet rigid standards of straightness, roundness and surface finish. The steel tubing is surface finished to minimize internal friction and prolong seal life.

5 Cylinder Body Seals

To make sure that the cylinder body remains leaktight, even under pressure shock conditions, Parker utilizes pressure-energized body seals.

6 One-Piece Piston

Side loading is resisted by the wide bearing surfaces of the pistons. A long thread engagement secures the piston to the piston rod and, as an added safety feature, pistons are secured by an anaerobic adhesive.

7 Cushioning

Progressive deceleration is available by using profiled cushions at the head and cap – see pages 23-25 for details. The head end cushion is self aligning, while the polished cap end spear is an integral part of the piston rod.

8 Floating Cushion Bushings and Sleeves

Closer tolerances – and therefore more effective cushioning – are permitted by the use of a floating cushion sleeve at the head end of the cylinder, and a floating cushion bushing at the cap end. A slotted cushion sleeve at the head end and the floating bronze cushion bushing in the cap, provide minimum fluid restriction at the start of the return stroke. This allows full pressure to be applied over the entire area of the piston, providing full power and fast cycle times.

9 Cushion Adjustment

Needle valves are provided at both ends of the cylinder for precise cushion adjustment. 63 mm bores and smaller contain cartridge cushion assembly shown below.

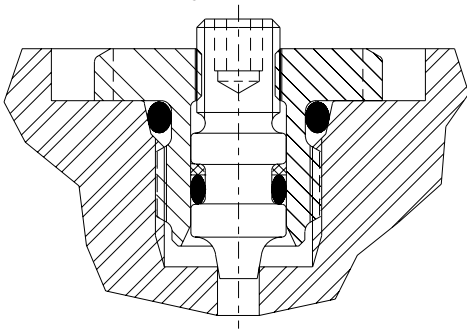

Air Bleeds

Available as an option at both ends, the air bleeds are recessed into the head and cap.

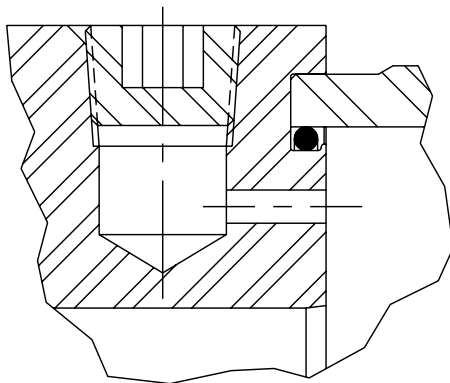

Gland Drains

The accumulation of fluid behind the gland wiperseal of long stroke cylinders, or cylinders with constant back pressure, can be relieved by specifying the option of a gland drain. A port between the wiperseal and primary seal allows fluid to be piped back to a reservoir. By fitting a transparent tube between the port and the reservoir, fluid loss from concealed or inaccessible cylinders can be monitored to provide an early indication of the need for gland servicing. Gland drains are described in greater detail on page 29.

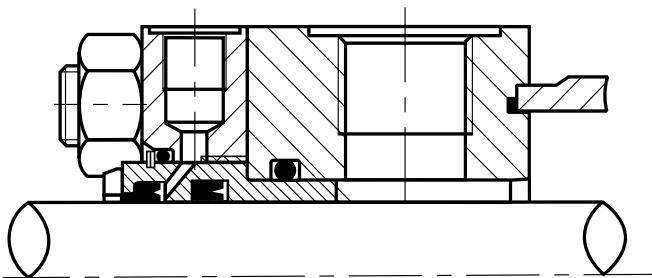

Piston Seals

Standard on 25mm, 32mm and 40mm bore sizes, Parker's Lipseal™ Piston provides zero leakage under static conditions for hydraulic pressures up to 3000 psi. Seals are self-compensating to conform to variations in pressure, mechanical deflection, and wear. Back-up washers prevent extrusion.

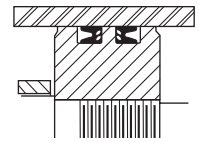

Standard on 50mm bore sizes and larger, Parker's B style piston is a single seal design which incorporates two wear strips. This design provides smooth operation, long bearing life, and high load carrying capacity.

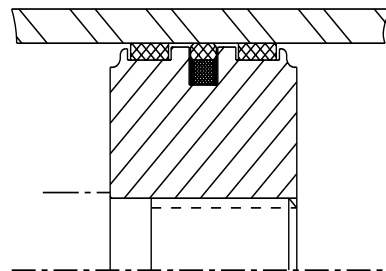

Mixed Media Piston Seals

For applications requiring different media on either side of the piston specify Mixed Media Piston Seals with a W piston code. This option is ideal when hydraulic oil is on one side of the piston and air on the opposite side; and it can be equally effective when dissimilar fluids are on either side of the piston. Superior low-friction bi-directional sealing is accomplished by combining an energized filled PTFE seal with a redundant elastomer seal.

Servo Cylinders

Servo cylinders permit fine control of acceleration, velocity and position in applications where very low friction and an absence of stick-slip are required. They may be used in conjunction with integral or external transducers. Servo cylinders combine low friction piston and gland seals with specially selected tubes and rods. For low-friction applications – consult factory.

Seal Classes

To accommodate the many types of fluids and the varying temperature ranges used in industry, Parker offers a range of rod gland, piston and body seals. These are described in detail on page 28.

**ISO Cylinder Mounting Styles
and Where to Find Them**

The standard range of Parker Series HMI cylinders comprises 12 ISO mounting styles, to suit the majority of applications. General guidance for the selection of ISO cylinders is given below, with dimensional information about each mounting style shown on the following pages. Application-specific mounting information is shown in the mounting information section on page 18.

Extended Tie Rods

Cylinders with TB, TC and TD mountings are suitable for straight line force transfer applications, and are particularly useful where space is limited. For compression (push) applications, cap end tie rod mountings are most appropriate; where the major load places the piston rod in tension (pull applications), head end mounting styles should be specified. Cylinders with tie rods extended at both ends may be attached to the machine member from either end, allowing the free end of the cylinder to support a bracket or switch.

Flange Mounted Cylinders

These cylinders are also suitable for use on straight line force transfer applications. Two flange mounting styles are available, offering either a head flange (JJ) or a cap flange (HH). Selection of the correct flange mounting style depends on whether the major force applied to the load will result in compression (push) or tension (pull) stresses on the piston rod. For compression-type applications, the cap mounting style is most appropriate; where the major load places the piston rod in tension, a head mounting should be specified.

Foot Mounted Cylinders

Style C, foot mounted cylinders do not absorb forces on their centerline. As a result, the application of force by the cylinder produces a moment which attempts to rotate the cylinder about its mounting bolts. It is important, therefore, that the cylinder should be firmly secured to the mounting surface and that the load should be effectively guided to avoid side loads being applied to rod gland and piston bearings. A thrust key modification may be specified to provide positive cylinder location.

Pivot Mountings

Cylinders with pivot mountings, which absorb forces on their centerlines, should be used where the machine member to be moved travels in a curved path. Pivot mountings may be used for tension (pull) or compression (push) applications. Cylinders using a fixed clevis, styles BB and B, may be used if the curved path of the piston rod travel is in a single plane; for applications where the piston rod will travel in a path on either side of the true plane of motion, a spherical bearing mounting SB is recommended.

Trunnion Mounted Cylinders

These cylinders, styles D, DB and DD, are designed to absorb force on their centerlines. They are suitable for tension (pull) or compression (push) applications, and may be used where the machine member to be moved travels in a curved path in a single plane. Trunnion pins are designed for shear loads only and should be subjected to minimum bending stresses.

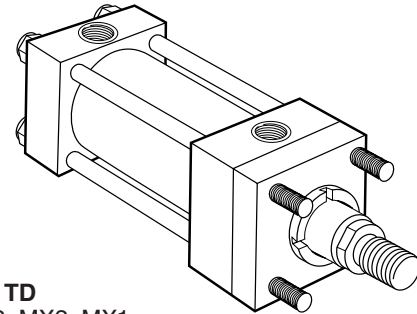

Styles TB, TC, TD
ISO Styles MX3, MX2, MX1

TB

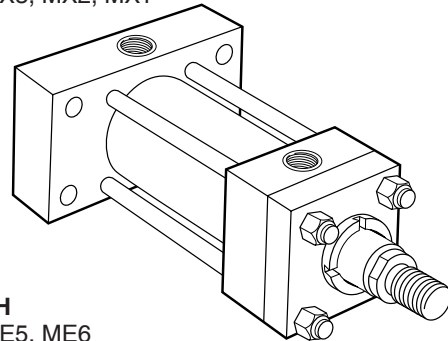

Styles JJ, HH
ISO Styles ME5, ME6

HH

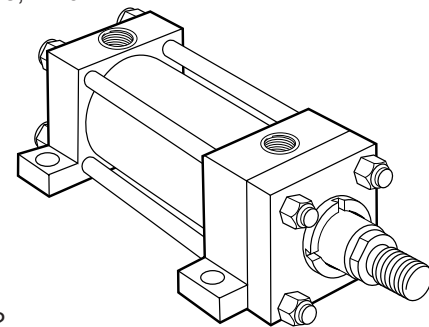

Style C
ISO Style MS2

C

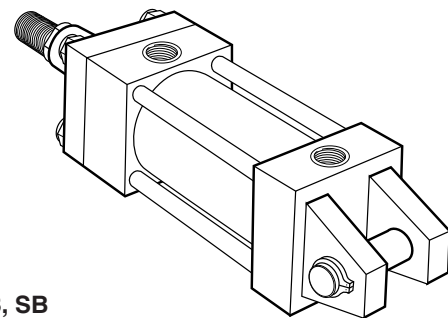

Styles B, BB, SB
ISO Styles MP3, MP1, MP5

BB

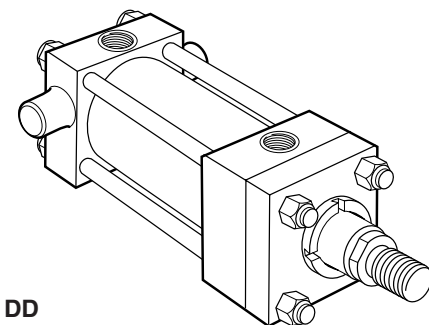

Styles D, DB, DD
ISO Styles MT1, MT2, MT4

DB

Parker Thread Styles 4 & 7 – All Except JJ Mount

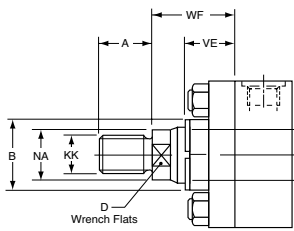

Parker Thread Styles 4 & 7 – JJ Mount

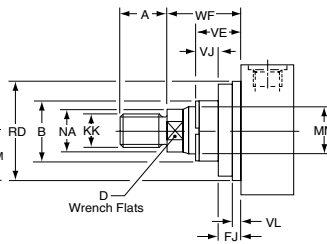

Parker Thread Style 9 – All Except JJ Mount

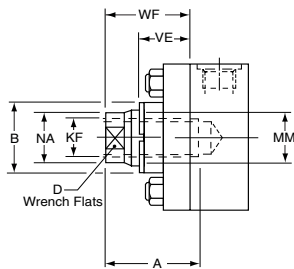

Parker Thread Style 9 – JJ Mount

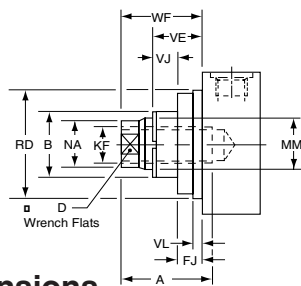

Piston Rod End Dimensions

Bore ϕ	Rod No.	MM Rod ϕ
25	1	12
	2	18
32	1	14
	2	22
40	1	18
	2	28
50	1	22
	2	36
	3	28
63	1	28
	2	45
	3	36
80	1	36
	2	56
	3	45
100	1	45
	2	70
	3	56
125	1	56
	2	90
	3	70
160	1	70
	2	110
	3	90
200	1	90
	2	140
	3	110

Style 4		Style 7		Style 9		B f9	D	NA	VE	WF
KK	A	KK	A	KF	A					
M10x1.25	14	-	-	M8x1	14	24	10	11	16	25
M14x1.5	18	M10x1.25	14	M12x1.25	18	30	15	17	16	25
M12x1.25	16	-	-	M10x1.25	16	26	12	13	22	35
M16x1.5	22	M12x1.25	16	M16x1.5	22	34	18	21	22	35
M14x1.5	18	-	-	M12x1.25	18	30	15	17	16	35
M20x1.5	28	M14x1.5	18	M20x1.5	28	42	22	26	22	35
M16x1.5	22	-	-	M16x1.5	22	34	18	21	22	41
M27x2	36	M16x1.5	22	M27x2	36	50	30	34	25	41
M20x1.5	28	M16x1.5	22	M20x1.5	28	42	22	26	22	41
M20x1.5	28	-	-	M20x1.5	28	42	22	26	22	48
M33x2	45	M20x1.5	28	M33x2	45	60	39	43	29	48
M27x2	36	M20x1.5	28	M27x2	36	50	30	34	25	48
M27x2	36	-	-	M27x2	36	50	30	34	25	51
M42x2	56	M27x2	36	M42x2	56	72	48	54	29	51
M33x2	45	M27x2	36	M33x2	45	60	39	43	29	51
M33x2	45	-	-	M33x2	45	60	39	43	29	57
M48x2	63	M33x2	45	M48x2	63	88	62	68	32	57
M42x2	56	M33x2	45	M42x2	56	72	48	54	29	57
M42x2	56	-	-	M42x2	56	72	48	54	29	57
M64x3	85	M42x2	56	M64x3	85	108	80	88	32	57
M48x2	63	M42x2	56	M48x2	63	88	62	68	32	57
M48x2	63	-	-	M48x2	63	88	62	68	32	57
M80x3	95	M48x2	63	M80x3	95	133	100	108	32	57
M64x3	85	M48x2	63	M64x3	85	108	80	88	32	57
M64x3	85	-	-	M64x3	85	108	80	88	32	57
M100x3	112	M64x3	85	M100x3	112	163	128	138	32	57
M80x3	95	M64x3	85	M80x3	95	133	100	108	32	57

25 & 32mm Bore Cylinders

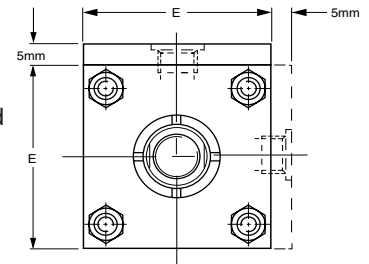

Parker Thread Styles 4 & 7
The smallest diameter rod end thread for each bore size is designated Style 4 when supplied with a No.1 rod. When the same rod end thread is supplied with a No. 2 or No. 3 rod, it is designated Style 7.

Parker Thread Style 9 – Short Stroke Cylinders
Style 9 (female) rod ends should not be used on 160mm or 200mm bore cylinders with a stroke of 50mm or less. Please consult the factory, with details of the application.

Parker Thread Style 3
Non-standard piston rod ends are designated 'Style 3'. A dimensional sketch or description should accompany the order. Please specify dimensions KK or KF, A, rod stand out WF and thread type.

5mm extra height applies to port face at head end only.

Gland Retainer – 160 and 200mm Bore
On all 160mm and 200mm bore ISO mounting styles except TB and TD, the gland retainer is separately bolted to the head, as shown.

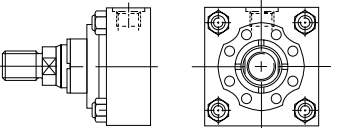

All dimensions are in millimeters unless otherwise stated.



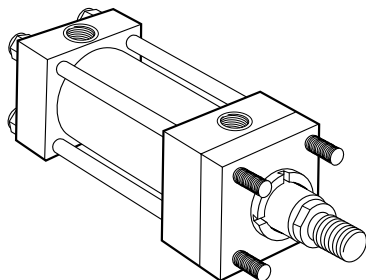

Style TB
Tie Rods Extended Head End
(ISO Style MX3)

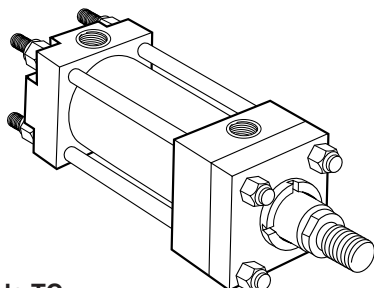
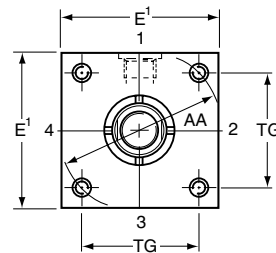
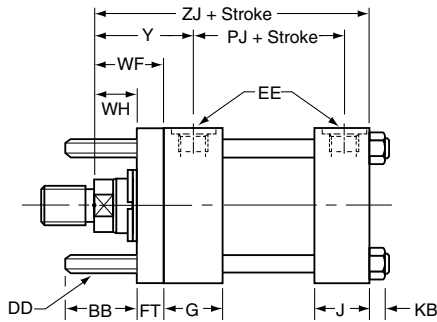

Style TC
Tie Rods Extended Cap End
(ISO Style MX2)

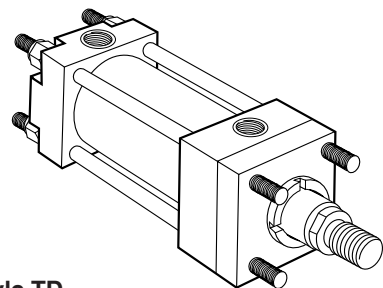
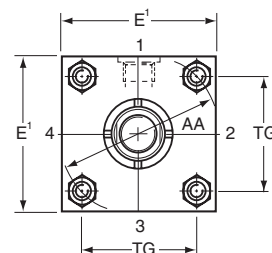
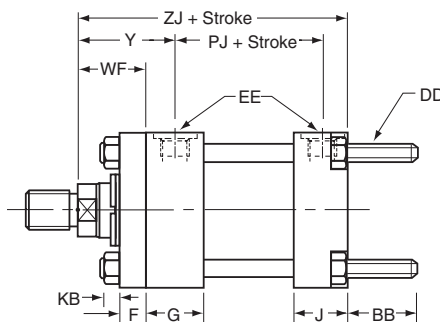

Style TD
Tie Rods Extended Both Ends
(ISO Style MX1)

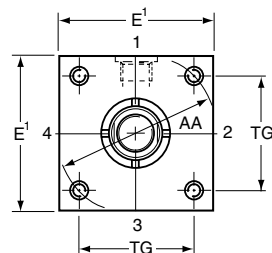
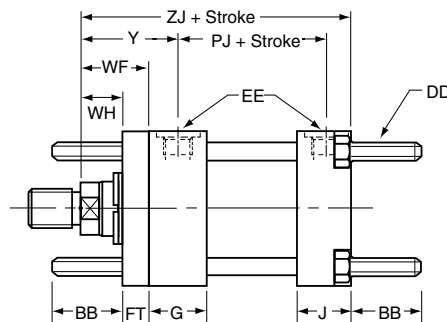

¹Head depth increased by 5mm to accommodate port on 25mm and 32mm bore cylinders – see page 5

Dimensions – TB, TC & TD See also Rod End Dimensions, page 5

Bore φ	AA	BB	DD	E	EE BSP/G inches	F	FT	G	J	KB	TG	WF	WH	Y	+ Stroke	
															PJ	ZJ
25	40	19	M5x0.8	40 ¹	1/4	10	10	40	25	4	28.3	25	15	50	53	114
32	47	24	M6x1	45 ¹	1/4	10	10	40	25	5	33.2	35	25	60	56	128
40	59	35	M8x1	63	3/8	10	10	45	38	6.5	41.7	35	25	62	73	153
50	74	46	M12x1.25	75	1/2	16	16	45	38	10	52.3	41	25	67	74	159
63	91	46	M12x1.25	90	1/2	16	16	45	38	10	64.3	48	32	71	80	168
80	117	59	M16x1.5	115	3/4	20	20	50	45	13	82.7	51	31	77	93	190
100	137	59	M16x1.5	130	3/4	22	22	50	45	13	96.9	57	35	82	101	203
125	178	81	M22x1.5	165	1	22	22	58	58	18	125.9	57	35	86	117	232
160	219	92	M27x2	205	1	25	25	58	58	22	154.9	57	32	86	130	245
200	269	115	M30x2	245	1-1/4	25	25	76	76	24	190.2	57	32	98	165	299

All dimensions are in millimeters unless otherwise stated.



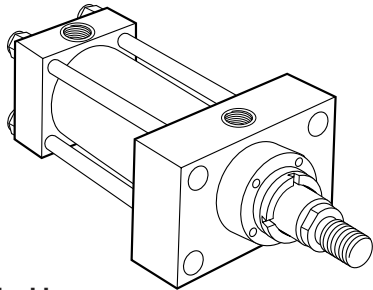

Style JJ
Head Rectangular Flange
(ISO Style ME5)

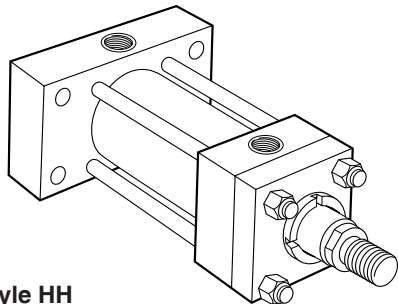
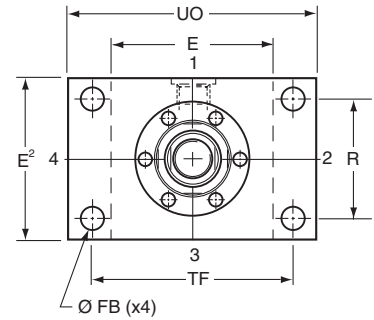
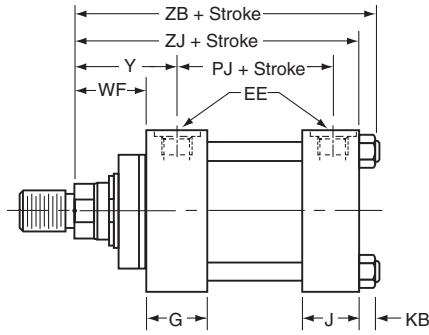

Style HH
Cap Rectangular Flange
(ISO Style ME6)

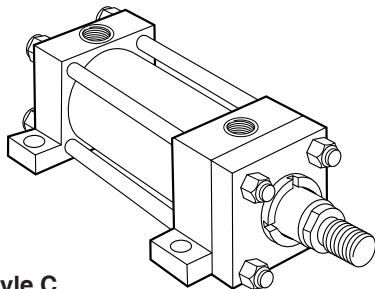
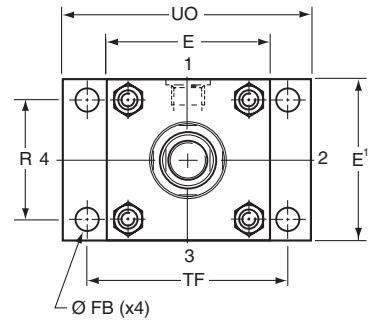
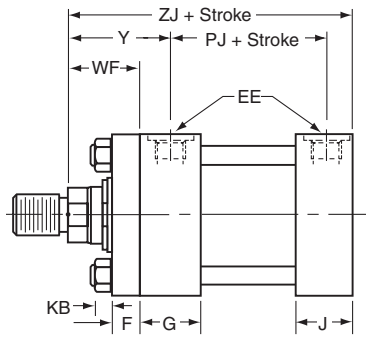

Style C
Side Lugs
(ISO Style MS2)

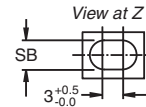
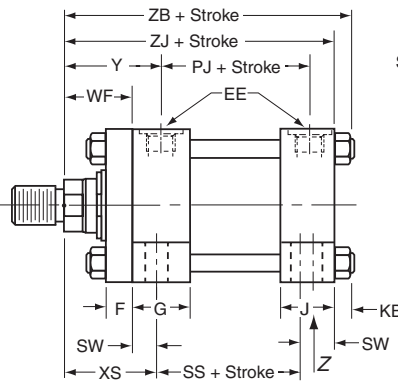

A thrust key may be used with this mounting style.

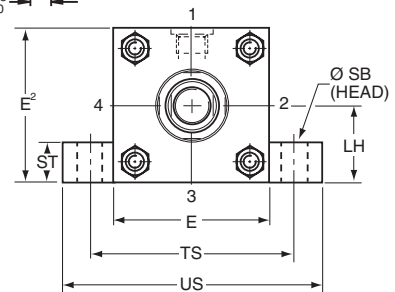

¹Head depth increased by 5mm to accommodate port on 25mm and 32mm bore cylinders – see page 5

²On 25mm and 32 mm bore C mount and JJ mount cylinders with port in position 2 or 4, head depth E is increased by 5mm in position 1.

Dimensions – JJ, HH & C See also Rod End Dimensions, page 5

Bore φ	E	EE BSP/G inches	F	FB	G	J	KB	LH	R	SB	ST	SW	TF	TS	UO	US	WF	XS	Y	+ Stroke			
																				PJ	SS	ZB	ZJ
25	40 ¹	1/4	10	5.5	40	25	4	19	27	6.6	8.5	8	51	54	65	72	25	33	50	53	72	121	114
32	45 ¹	1/4	10	6.6	40	25	5	22	33	9	12.5	10	58	63	70	84	35	45	60	56	72	137	128
40	63	3/8	10	11	45	38	6.5	31	41	11	12.5	10	87	83	110	103	35	45	62	73	97	166	153
50	75	1/2	16	14	45	38	10	37	52	14	19	13	105	102	130	127	41	54	67	74	91	176	159
63	90	1/2	16	14	45	38	10	44	65	18	26	17	117	124	145	161	48	65	71	80	85	185	168
80	115	3/4	20	18	50	45	13	57	83	18	26	17	149	149	180	186	51	68	77	93	104	212	190
100	130	3/4	22	18	50	45	13	63	97	26	32	22	162	172	200	216	57	79	82	101	101	225	203
125	165	1	22	22	58	58	18	82	126	26	32	22	208	210	250	254	57	79	86	117	130	260	232
160	205	1	25	26	58	58	22	101	155	33	38	29	253	260	300	318	57	86	86	130	129	279	245
200	245	1-1/4	25	33	76	76	24	122	190	39	44	35	300	311	360	381	57	92	98	165	171	336	299

All dimensions are in millimeters unless otherwise stated.



Style B
Cap Fixed Eye
(ISO Style MP3)

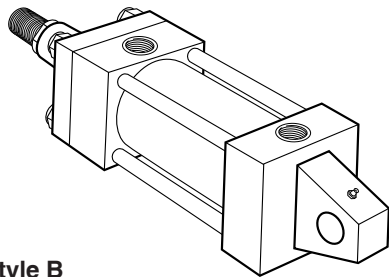

Pivot pin not supplied

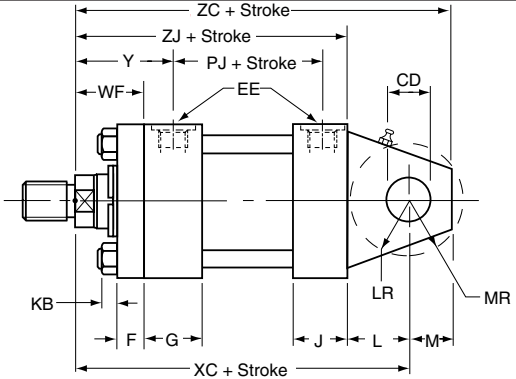
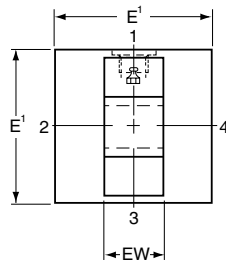

Style BB
Cap Fixed Clevis
(ISO Style MP1)

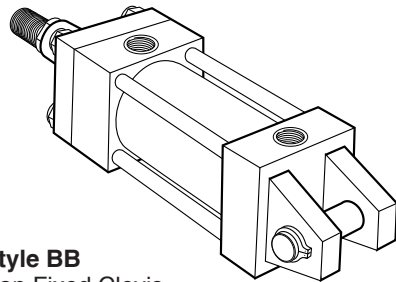

Supplied complete with pivot pin

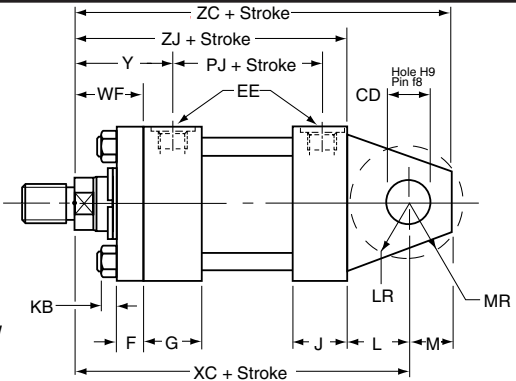
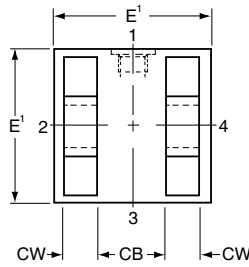

Style SB*
Cap Fixed Eye
(ISO Style MP5)

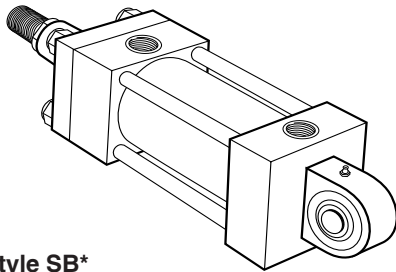

Pivot pin not supplied

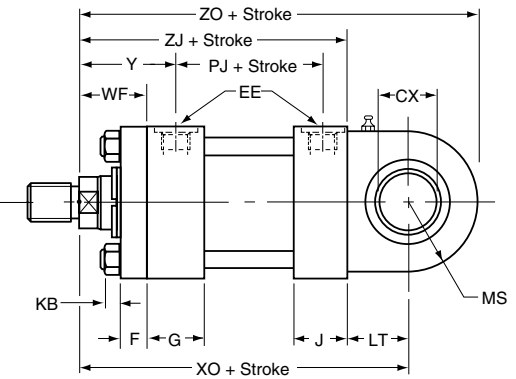
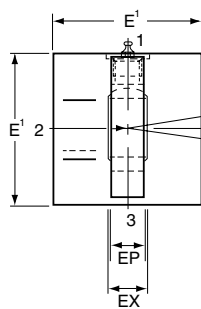

*Head depth increased by 5mm to accommodate port on 25mm and 32mm bore cylinders – see page 5

*Parker Style SB is also known as Style SBd under Parker's European model code system

Dimensions – B, BB & SB See also Rod End Dimensions, page 5

Bore φ	CB A16	CD H9	CW	CX	E	EE BSP/G inches	EP h14	EW	EX	F	G	J	KB	L	LR	LT	M	MR	MS max	WF	Y	+ Stroke					
																						PJ	XC	XO	ZC	ZJ	ZO
25	12	10	6	12-0.008	40 ¹	1/4	8	12	10	10	40	25	4	13	12	16	10	12	20	25	50	53	127	130	137	114	150
32	16	12	8	16-0.008	45 ¹	1/4	11	16	14	10	40	25	5	19	17	20	12	15	22.5	35	60	56	147	148	159	128	170.5
40	20	14	10	20-0.012	63	3/8	13	20	16	10	45	38	6.5	19	17	25	14	16	29	35	62	73	172	178	186	153	207
50	30	20	15	25-0.012	76	1/2	17	30	20	16	45	38	10	32	29	31	20	25	33	41	67	74	191	190	211	159	223
63	30	20	15	30-0.012	90	1/2	19	30	22	16	45	38	10	32	29	38	20	25	40	48	71	80	200	206	220	168	246
80	40	28	20	40-0.012	115	3/4	23	40	28	20	50	45	13	39	34	48	28	34	50	51	77	93	229	238	257	190	288
100	50	36	25	50-0.012	130	3/4	30	50	35	22	50	45	13	54	50	58	36	44	62	57	82	101	257	261	293	203	323
125	60	45	30	60-0.015	165	1	38	60	44	22	58	58	18	57	53	72	45	53	80	57	86	117	289	304	334	232	384
160	70	56	35	80-0.015	205	1	47	70	55	25	58	58	22	63	59	92	59	59	100	57	86	130	308	337	367	245	437
200	80	70	40	100-0.020	245	1-1/4	57	80	70	25	76	76	24	82	78	116	70	76	120	57	98	165	381	415	451	299	535

All dimensions are in millimeters unless otherwise stated.



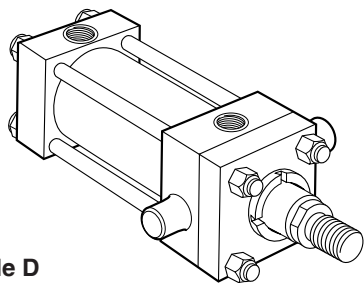

Style D
 Head Trunnion
 (ISO Style MT1)

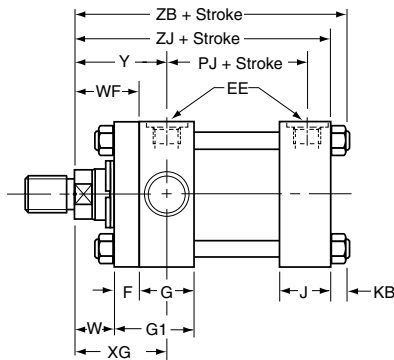

Notes:

A one-piece head and retainer is used on 100mm-200mm bore sizes – G1 dimension. On 160 and 200mm bores, the bolted gland is recessed, with tie rods screwed into the head.

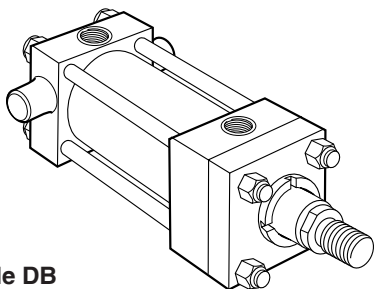
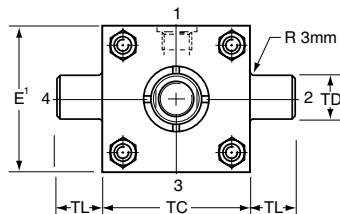

Style DB
 Cap Trunnion
 (ISO Style MT2)

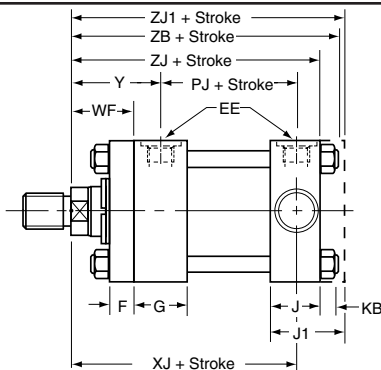

Note:

On 100-200mm bore cylinders, dimension J becomes J1. ZJ1 replaces ZB, and tie rods are screwed directly into the cap.

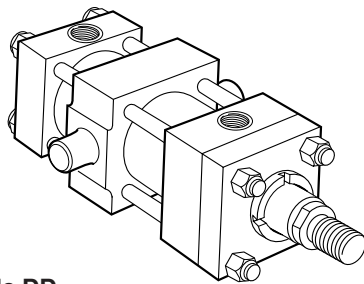
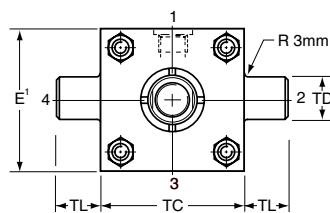

Style DD
 Intermediate Fixed Trunnion
 (ISO Style MT4)

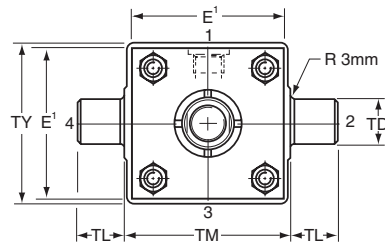
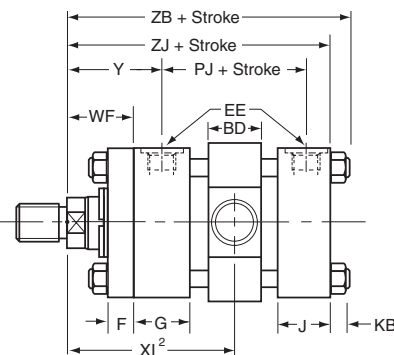

¹Head depth increased by 5mm to accommodate port on 25mm and 32mm bore cylinders – see page 5

²Dimensions to be specified by customer

Dimensions – D, DB & DD See also Rod End Dimensions, page 5

Bore φ	BD	E	EE BSP/G inches	F	G	G1	J	J1	KB	TC	TD	TL	TM	TY	W	WF	XG	Y	+ Stroke					Style DD min stroke	Min XI dim'n
																			PJ	XJ	ZJ	ZJ1	ZB		
25	20	40 ¹	1/4	10	40	-	25	-	4	38	12	10	48	45	-	25	44	50	53	101	114	-	121	10	78
32	25	45 ¹	1/4	10	40	-	25	-	5	44	16	12	55	54	-	35	54	60	56	115	128	-	137	10	90
40	30	63	3/8	10	45	-	38	-	6.5	63	20	16	76	76	-	35	57	62	73	134	153	-	166	15	97
50	40	76	1/2	16	45	-	38	-	10	76	25	20	89	89	-	41	64	67	74	140	159	-	176	15	107
63	40	90	1/2	16	45	-	38	-	10	89	32	25	100	95	-	48	70	71	80	149	168	-	185	15	114
80	50	115	3/4	20	50	-	45	50	13	114	40	32	127	127	-	51	76	77	93	168	190	194	212	20	127
100	60	130	3/4	22	50	72	45	58	13	127	50	40	140	140	35	57	71	82	101	187	203	216	225	20	138
125	73	165	1	22	58	80	58	71	18	165	63	50	178	178	35	57	75	86	117	209	232	245	260	25	153
160	90	205	1	25	58	88	58	88	22	203	80	63	215	216	32	57	75	86	130	230	245	275	279	30	161
200	110	245	1-1/4	25	76	108	76	108	24	241	100	80	279	280	32	57	85	98	165	276	299	330	336	30	190

All dimensions are in millimeters unless otherwise stated.



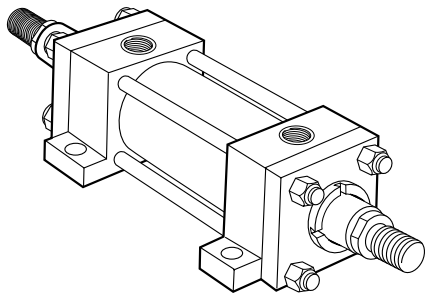

Double Rod Cylinder
 Available with Styles TB, TD, JJ,
 C, D, DD (Style C illustrated)

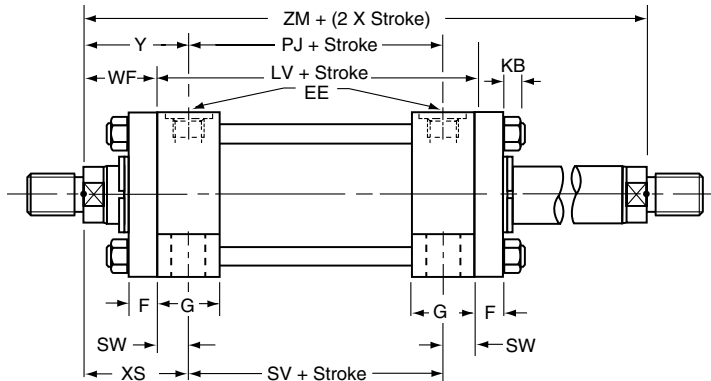

Mounting Styles and Codes

Double rod cylinders are denoted by a 'K' in the ISO cylinder model code.

Dimensions

To obtain dimensional information for double rod cylinders, first select the desired mounting style by referring to the corresponding single rod model. Dimensions for the appropriate single rod model should be supplemented by those from the table opposite to provide a full set of dimensions.

Minimum Stroke Length – Style 9 Rod End

Where a style 9 (female) piston rod end is required on a double rod cylinder with a stroke of 80mm or less, and a bore of 80mm or above, please consult the factory.

Bore φ	Rod		Add Stroke			Add 2x Stroke
	No.	MM φ	LV	PJ	SV	ZM
25	1	12	104	53	88	154
	2	18				
32	1	14	108	56	88	178
	2	22				
40	1	18	125	73	105	195
	2	28				
50	1	22	125	74	99	207
	2	36				
	3	28				
63	1	28	127	80	93	223
	2	45				
	3	36				
80	1	36	144	93	110	246
	2	56				
	3	45				
100	1	45	151	101	107	265
	2	70				
	3	56				
125	1	56	175	117	131	289
	2	90				
	3	70				
160	1	70	188	130	130	302
	2	110				
	3	90				
200	1	90	242	160	172	356
	2	140				
	3	110				

Double Rod Cylinders

For double rod cylinders, specify rod number and rod end symbols for both piston rods. A typical model number for a double rod cylinder would be:

100	K	JJ	HMI	R	E	1	4	M	1	4	M	125	M	11	44
-----	---	----	-----	---	---	---	---	---	---	---	---	-----	---	----	----

All dimensions are in millimeters unless otherwise stated.

Accessory Selection

Accessories for the rod end of a cylinder are selected by reference to the rod end thread, while the same accessories, when used at the cap end, are selected by cylinder bore size. See tables of part numbers below, and on the following pages.

The rod clevises, plain rod eyes and spherical bearings fitted as accessories to the rod end have the same pin diameters as those used at the cylinder cap ends of the corresponding mounting styles – B, BB and SB – when fitted with the No. 1 rod, or the No. 2 or No. 3 rods with Style 7 rod end.

Rod and Cap End Accessories

Accessories for the HMI ISO cylinder include:

- Rod End** – rod clevis, eye bracket and pivot pin
- plain rod eye, clevis bracket and pivot pin
- rod eye with spherical bearing
- Cap End** – eye bracket for style BB mounting
- clevis bracket for style B mounting
- pivot pin for eye bracket and clevis bracket

Rod Clevis, Eye Bracket and Pivot Pin

KK Thread	Rod Clevis	Eye Bracket	Pivot Pin	Nominal Force kN	Weight kg
M10x1.25	1434470000	1448080000	1434770000	8	0.3
M12x1.25	1434480000	1448090000	1434780000	12.5	0.6
M14x1.5	1434490000	1448100000	1434790000	20	0.8
M16x1.5	1434500000	1448110000	1434800000	32	2.2
M20x1.5	1434510000	1448120000	1434800000	50	2.7
M27x2	1434520000	1448130000	1434810000	80	5.9
M33x2	1434530000	1448140000	1434820000	125	9.4
M42x2	1434540000	1448150000	1434830000	200	17.8
M48x2	1434550000	1448160000	1434840000	320	26.8
M64x3	1434560000	1448170000	1434850000	500	39.0

Rod Clevis Dimensions

Part No.	AV	CE	CK Ø H9	CL	CM A16	CR	ER	KK Thread	LE	Weight kg
1434470000	17	32	10	25	12	20	12	M10x1.25	14	0.08
1434480000	16	36	12	32	16	32	17	M12x1.25	19	0.25
1434490000	18	38	14	40	20	30	17	M14x1.5	19	0.32
1434500000	22	54	20	60	30	50	29	M16x1.5	32	1.0
1434510000	28	60	20	60	30	50	29	M20x1.5	32	1.1
1434520000	36	75	28	83	40	61	34	M27x2	39	2.3
1434530000	45	99	36	103	50	76	50	M33x2	54	2.6
1434540000	56	113	45	123	60	102	53	M42x2	57	5.5
1434550000	63	126	56	143	70	112	59	M48x2	63	7.6
1434560000	85	168	70	163	80	146	78	M64x3	83	13.0

Rod Clevis

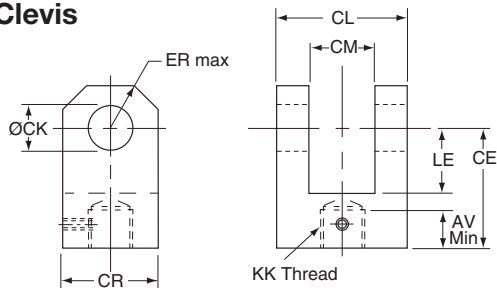

Pivot Pin for Clevis Bracket and Plain Rod Eye – Dimensions

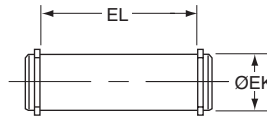

Part No.	EK Ø f8	EL	Weight kg
1434770000	10	29	0.02
1434780000	12	37	0.05
1434790000	14	45	0.08
1434800000	20	66	0.2
1434810000	28	87	0.4
1434820000	36	107	1.0
1434830000	45	129	1.8
1434840000	56	149	4.2
1434850000	70	169	6.0

Eye Bracket – for Cap Clevis Mount

Bore Ø	Eye Bracket	Nominal Force kN	Weight kg
25	1448080000	8	0.2
32	1448090000	12.5	0.3
40	1448100000	20	0.4
50	1448110000	32	1.0
63	1448120000	50	1.4
80	1448130000	80	3.2
100	1448140000	125	5.6
125	1448150000	200	10.5
160	1448160000	320	15.0
200	1448170000	500	20.0

Eye Bracket Dimensions

Part No.	CK Ø H9	EM h13	FL	MR max	LE min	AA Ø	HB Ø	TG	UD
1448080000	10	12	23	12	13	40	5.5	28.3	40
1448090000	12	16	29	17	19	47	6.6	33.2	45
1448100000	14	20	29	17	19	59	9	41.7	65
1448110000	20	30	48	29	32	74	13.5	52.3	75
1448120000	20	30	48	29	32	91	13.5	64.3	90
1448130000	28	40	59	34	39	117	17.5	82.7	115
1448140000	36	50	79	50	54	137	17.5	96.9	130
1448150000	45	60	87	53	57	178	26	125.9	165
1448160000	56	70	103	59	63	219	30	154.9	205
1448170000	70	80	132	78	82	269	33	190.2	240

Eye Bracket

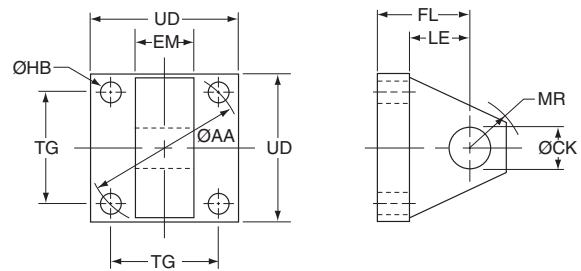

All dimensions are in millimeters unless otherwise stated.

Plain Rod Eye, Clevis Bracket and Pivot Pin

KK Thread	Plain Rod Eye	Clevis Bracket	Pivot Pin	Nominal Force kN	Weight kg
M10x1.25	1434570000	1436460000	1434770000	8	0.5
M12x1.25	1434580000	1436470000	1434780000	12.5	1.0
M14x1.5	1434590000	1436480000	1434790000	20	1.3
M16x1.5	1434600000	1436490000	1434800000	32	3.2
M20x1.5	1434610000	1436490000	1434800000	50	3.8
M27x2	1434620000	1436500000	1434810000	80	6.9
M33x2	1434630000	1436510000	1434820000	125	12.5
M42x2	1434640000	1436520000	1434830000	200	26.0
M48x2	1434650000	1436530000	1434840000	320	47.0
M64x3	1434660000	1436540000	1434850000	500	64.0

Plain Rod Eye / Knuckle Dimensions

Part No.	AW	CA	CB	CD	CK Ø H9	EM h13	ER	KK Thread	LE	Weight kg
1434570000	14	32	18	9	10	12	12	M10x1.25	13	0.08
1434580000	16	36	22	11	12	16	17	M12x1.25	19	0.15
1434590000	18	38	20	12.5	14	20	17	M14x1.5	19	0.22
1434600000	22	54	30	17.5	20	30	29	M16x1.5	32	0.5
1434610000	28	60	30	20	20	30	29	M20x1.5	32	1.1
1434620000	36	75	40	25	28	40	34	M27x2	39	1.5
1434630000	45	99	50	35	36	50	50	M33x2	54	2.5
1434640000	56	113	65	50	45	60	53	M42x2	57	4.2
1434650000	63	126	90	56	56	70	59	M48x2	63	11.8
1434660000	85	168	110	70	70	80	78	M64x3	83	17.0

Plain Rod Eye / Knuckle

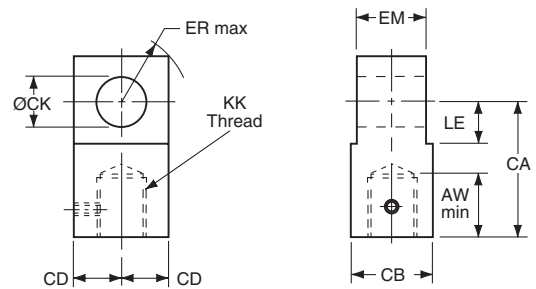

Clevis Bracket Dimensions

Part No.	CK Ø H9	CM A16	CW	FL	MR max	HB	LE min	RC	TB	UR	UH
1436460000	10	12	6	23	12	5.5	13	18	47	35	60
1436470000	12	16	8	29	17	6.6	19	24	57	45	70
1436480000	14	20	10	29	17	9	19	30	68	55	85
1436490000	20	30	15	48	29	13.5	32	45	102	80	125
1436500000	28	40	20	59	34	17.5	39	60	135	100	170
1436510000	36	50	25	79	50	17.5	54	75	167	130	200
1436520000	45	60	30	87	53	26	57	90	183	150	230
1436530000	56	70	35	103	59	30	63	105	242	180	300
1436540000	70	80	40	132	78	33	82	120	300	200	360

Clevis Bracket

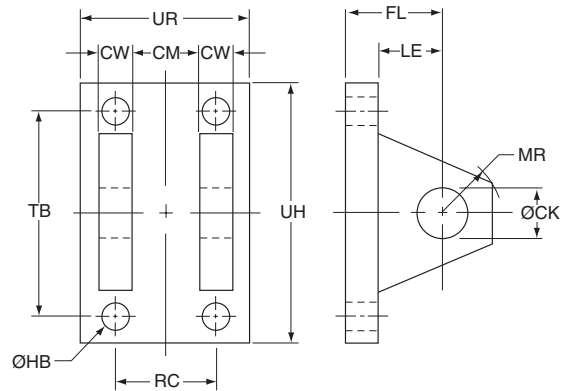

Clevis Bracket – for Cap Eye Mount

Bore Ø	Part No.	Nominal Force kN	Weight kg
25	1436460000	8	0.4
32	1436470000	12.5	0.8
40	1436480000	20	1.0
50	1436490000	32	2.5
63	1436490000	50	2.5
80	1436500000	80	5.0
100	1436510000	125	9.0
125	1436520000	200	20.0
160	1436530000	320	31.0
200	1436540000	500	41.0

Pivot Pin for Clevis Bracket and Plain Rod Eye – Dimensions

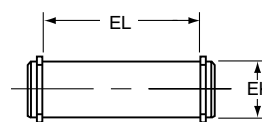

All dimensions are in millimeters unless otherwise stated.

Part No.	EK Ø f8	EL	Weight kg
1434770000	10	29	0.02
1434780000	12	37	0.05
1434790000	14	45	0.08
1434800000	20	66	0.2
1434810000	28	87	0.4
1434820000	36	107	1.0
1434830000	45	129	1.8
1434840000	56	149	4.2
1434850000	70	169	6.0

**Rod Eye with Spherical Bearing,
Mounting Bracket and Pivot Pin**

KK Thread	Rod Eye with Spherical Bearing	Mounting Bracket and Pivot Pin	Nominal Force kN	Weight kg
M10x1.25	1452540000	1455300000	8	0.2
M12x1.25	1452550000	1455310000	12.5	0.3
M14x1.5	1452560000	1455320000	20	0.4
M16x1.5	1452570000	1455330000	32	0.7
M20x1.5	1452580000	1455340000	50	1.3
M27x2	1452590000	1455350000	80	2.3
M33x2	1452600000	1455360000	125	4.4
M42x2	1452610000	1455370000	200	8.4
M48x2	1452620000	1455380000	320	15.6
M64x3	1452630000	1455390000	500	28.0

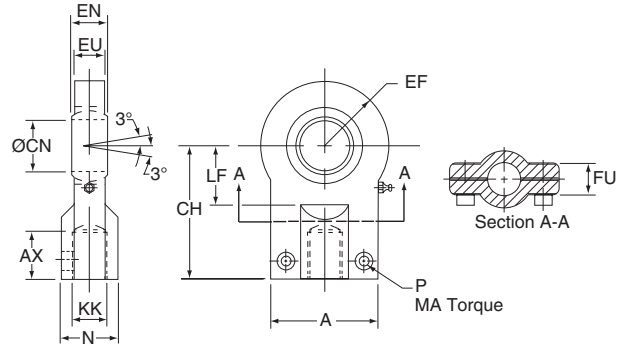

Rod Eye with Spherical Bearing

All spherical bearings should be re-packed with grease when servicing. In unusual or severe working conditions, consult the factory regarding the suitability of the bearing chosen.

Rod Eye with Spherical Bearing Dimensions

Part No.	A max	AX min	EF max	CH	CN Ø	EN	EU	FU	KK Thread	LF min	N max	MA max Nm	P
1452540000	40	15	20	42	12 -0.008	10 -.012	8	13	M10x1.25	16	17	10	M6
1452550000	45	17	22.5	48	16 -0.008	14 -.012	11	13	M12x1.25	20	21	10	M6
1452560000	55	19	27.5	58	20 -0.012	16 -.012	13	17	M14x1.5	25	25	25	M8
1452570000	62	23	32.5	68	25 -0.012	20 -.012	17	17	M16x1.5	30	30	25	M8
1452580000	80	29	40	85	30 -0.012	22 -.012	19	19	M20x1.5	35	36	45	M10
1452590000	90	37	50	105	40 -0.012	28 -.012	23	23	M27x2	45	45	45	M10
1452600000	105	46	62.5	130	50 -0.012	35 -.012	30	30	M33x2	58	55	80	M12
1452610000	134	57	80	150	60 -0.015	44 -.015	38	38	M42x2	68	68	160	M16
1452620000	156	64	102.5	185	80 -0.015	55 -.015	47	47	M48x2	92	90	310	M20
1452630000	190	86	120	240	100 -0.020	70 -.020	57	57	M64x3	116	110	530	M24

Mounting Bracket and Pivot Pin Dimensions

Part No.	CF Ø K7/h6	CG +0.1, +0.3	CO N9	CP	FM js11	FO js14	GL js13	HB Ø	KC 0, +0.30	LG	LJ	LO	RE js13	SR max	TA js13	UJ	UK
1455300000	12	10	10	30	40	16	46	9	3.3	28	29	56	55	12	40	75	60
1455310000	16	14	16	40	50	18	61	11	4.3	37	38	74	70	16	55	95	80
1455320000	20	16	16	50	55	20	64	14	4.3	39	40	80	85	20	58	120	90
1455330000	25	20	25	60	65	22	78	16	5.4	48	49	98	100	25	70	140	110
1455340000	30	22	25	70	85	24	97	18	5.4	62	63	120	115	30	90	160	135
1455350000	40	28	36	80	100	24	123	22	8.4	72	73	148	135	40	120	190	170
1455360000	50	35	36	100	125	35	155	30	8.4	90	92	190	170	50	145	240	215
1455370000	60	44	50	120	150	35	187	39	11.4	108	110	225	200	60	185	270	260
1455380000	80	55	50	160	190	35	255	45	11.4	140	142	295	240	80	260	320	340
1455390000	100	70	63	200	210	35	285	48	12.4	150	152	335	300	100	300	400	400

Cap Mounting Bracket and Pivot Pin

Bore Ø	Mounting Bracket and Pivot Pin	Nominal Force kN	Weight kg
25	1455300000	8	0.6
32	1455310000	12.5	1.3
40	1455320000	20	2.1
50	1455330000	32	3.2
63	1455340000	50	6.5
80	1455350000	80	12.0
100	1455360000	125	23.0
125	1455370000	200	37.0
160	1455380000	320	79.0
200	1455390000	500	140.0

Mounting Bracket and Pivot Pin

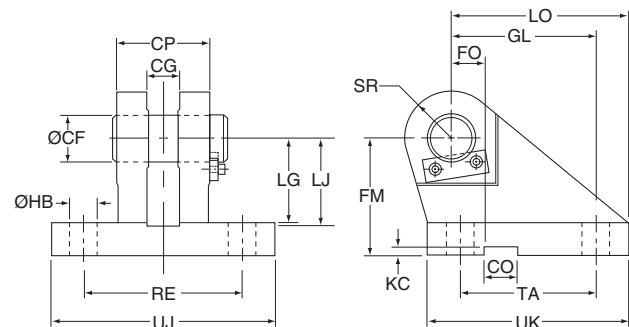

All dimensions are in millimeters unless otherwise stated.

How to Order ISO Cylinders

Data Required On All Cylinder Orders

When ordering Series HMI cylinders, be sure to specify each of the following requirements:

(NOTE: – Duplicate cylinders can be ordered by giving the SERIAL NUMBER from the nameplate of the original cylinder. Factory records supply a quick, positive identification.)

a) Bore Size

b) Mounting Style

Specify your choice of mounting style – as shown and dimensioned in this catalog. If double rod is required, specify “with double rod.”

c) Series Designation (“HMI”)

d) Length of Stroke

e) Piston Rod Diameter

Call out rod diameter or rod code number. In Series HMI cylinders, standard rod diameters (Code No. 1) will be furnished if not otherwise specified, unless length of stroke makes the application questionable.

f) Piston Rod End Thread Style

Call out thread style number or specify dimensions. Thread style number 4 will be furnished if not otherwise specified.

g) Cushions (if required)

Specify “Cushion-head end,” “Cushion-cap end” or “Cushion-both ends” as required. If cylinder is to have a double rod and only one cushion is required, be sure to specify clearly which end of the cylinder is to be cushioned.

h) Piston

Parker B style pistons are standard. Fluorocarbon also available.

i) Ports

BSP (ISO 228) are standard.

j) Fluid Medium

Series HMI hydraulic cylinders are equipped with seals for use with hydraulic oil. If other than hydraulic oil will be used, consult factory.

ADDITIONAL DATA is required on orders for cylinders with special modifications.
For further information, consult factory.

Service Policy

On cylinders returned to the factory for repairs, it is standard policy for the Cylinder Division to make such part replacements as will put the cylinder in as good as new condition. Should the condition of the returned cylinder be such that expenses for repair would exceed the costs of a new one, you will be notified.

Address all correspondence to Service Department at your nearest regional plant listed in the pages of this catalog.

Certified Dimensions

Parker Cylinder Division guarantees that all cylinders ordered from this catalog will be built to dimensions shown. All dimensions are certified to be correct, and thus it is not necessary to request certified drawings.

Series HMI Model Numbers – How to Develop and “Decode” Them

Parker Series HMI cylinders can be completely and accurately described by a model number consisting of coded symbols.

To develop a model number, select only those symbols that represent the cylinder required, and place them in the sequence indicated below.

Feature	Description	Page	Symbol	Example																							
				80	C	K	C	K	HMI	R	B	S	1	4	M	C	230	M	11	44							
Bore	Millimeters		–	●																							
Cushion – Head	If required	23	C	○																							
Double Rod	If required	10	K	○																							
Mounting Style	Head Tie Rods Extended	6	T																								
	Cap Tie Rods Extended	6	TC																								
	Both Ends Tie Rods Extended	6	TD																								
	Head Rectangular	7	JJ																								
	Cap Rectangular	7	HH																								
	Side Lugs	7	C	●																							
	Cap Fixed Eye	8	B	●																							
	Cap Fixed Clevis	8	BB	●																							
	Cap Fixed Eye with Spherical Bearing*	8	SB*	○																							
	Head Trunnion	9	D	○																							
Cap Trunnion	9	DB	○																								
Intermediate Fixed Trunnion‡	9	DD	○																								
Mounting Modifications	Thrust Key for Style C mounting only – Thrust key - 25mm & 32mm bores	10	P	○																							
	– Thrust key - 40mm bore and larger	10	K	○																							
Series	Series name		HMI	●																							
Ports	BSP (ISO 228) – standard	27	R	●																							
	BSPT (Taper Thread)	27	B	●																							
	Metric Thread	27	M	●																							
	Metric Thread per ISO 6149	27	Y	●																							
	SAE – Straight Thread O-ring Port	27	T	●																							
	NPTF (Dry Seal Pipe Thread)	27	U	●																							
	SAE – Flange Ports (3000 PSI)	27	P	●																							
Piston	Lipseal™ Piston** (standard 25mm - 40mm bores)	3	L	●																							
	B-Style Low Friction filled PTFE seals (standard 50mm - 200mm bores)	3	B	●																							
	Mixed Media Low Friction Piston seal (Optional 25mm - 200mm bores)	3	W	○																							
Special Features	One or more of the following:		S	○																							
	Gland Drain Port	29																									
	Oversize Ports	26																									
	Rod End Bellows	28																									
	Stop Tube	21																									
	Stroke Adjuster	29																									
	Tie Rod Supports	19																									
	Water Service Modifications Or to detailed descriptions or drawings supplied by customer	28																									
Piston Rod Number	Rod No. 1	5	1	●																							
	Rod No. 2	5	2	●																							
	Rod No. 3	5	3	●																							
Piston Rod End	Style 4	5	4	●																							
	Style 7	5	7	●																							
	Style 9	5	9	●																							
	Style 3 (Special) Please supply description or drawing	5	3	●																							
Rod Thread	Metric (standard)	5	M	●																							
Cushion – Cap	If required	23	C	○																							
Gross Stroke	Millimeters		–	●																							
Fluid Medium ISO 6743/4 (1982)	Mineral Oil HH, HL, HLP, HLP-D, HM, HV, MIL-H-5606 Oil, Air, Nitrogen	28	M	●																							
	Fluorocarbon	28	D	●																							
Port Positions	Head position 1-4	29	1	●																							
	Cap position 1-4	29	1	●																							
Air Bleeds	Head position 1-4	29	4	●																							
	Cap position 1-4	29	4	●																							
	No Air Bleed	29	00	●																							

*Mounting Style SB is also known as Parker Style SBd in Parker's European model code system.

‡Specify XI dimension.

**Lipseal piston not available 50mm - 200mm bores. Contact factory regarding B-style piston availability in 25mm - 40mm bores.

Key: ● Essential information
○ Optional features

Service Assemblies and Seal Kits

Service Assembly Kits and Seal Kits for HMI cylinders simplify the ordering and maintenance processes. They contain sub-assemblies which are ready for installation, and are supplied with full instructions. When ordering Service Assemblies and Seal Kits, please refer to the identification plate on the cylinder body, and supply the following information:

Serial Number - Bore - Stroke - Model Number - Fluid Type

Key to Part Numbers

- 1 Head
- 7 Cap
- 14 Gland/Bearing cartridge
- 15 Cylinder body
- 17 Piston
- 18 Cushion sleeve
- 19 Tie rod
- 23 Tie rod nut
- 26 Back-up washer (not 25-50mm bore cylinders)

- 27 Retainer
- 34 Piston rod – single rod, no cushion
- 35 Piston rod – single rod, cushion at head end
- 36 Piston rod – single rod, cushion at cap end
- 37 Piston rod – single rod, cushion at both ends
- 40 Wiperseal – for 14 and 122
- 41 Lipseal – for 14
- 42 Lipseal, Piston 25-40mm bores only
- 43 Back-up washer, bushing lipseal 41 (not Group 1 seals)
- 44 Back-up washer, piston lipseal
- 45 O-ring – gland/head
- 47 O-ring – cylinder body
- 57¹ Piston rod – double rod, no cushion
- 58¹ Piston rod – double rod, cushion one end
- 60¹ Piston rod – double rod, no cushion
- 61¹ Piston rod – double rod, cushion one end
- 69 O-ring – needle valve and check valve screws
- 70² Needle valve, cushion adjustment
- 70a² Needle valve, cushion adjustment – cartridge type
- 70b Cartridge screw
- 70c O-ring – cartridge screw
- 70d Needle screw
- 70e Back-up washer – needle screw

- 70f O-ring – needle screw
- 71 Ball – cushion check valve
- 72 Cushion check valve screw
- 73 Floating cushion bushing
- 74 Retaining ring for cushion bushing
- 125 Standard piston seal
- 126 Energizing ring for standard seal 125
- 127 Wear ring for standard piston

¹Not illustrated

²In some cases, the adjusting screw is installed in a cartridge.

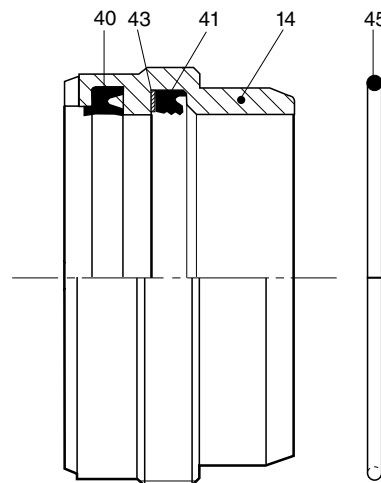
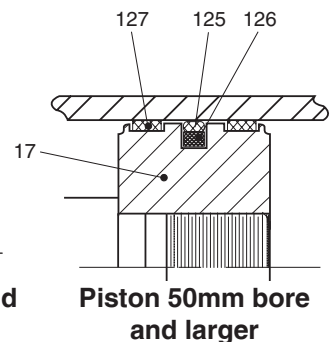
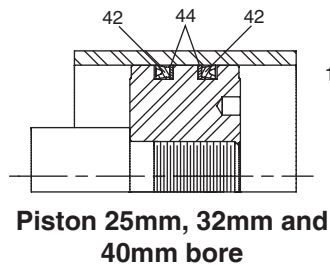
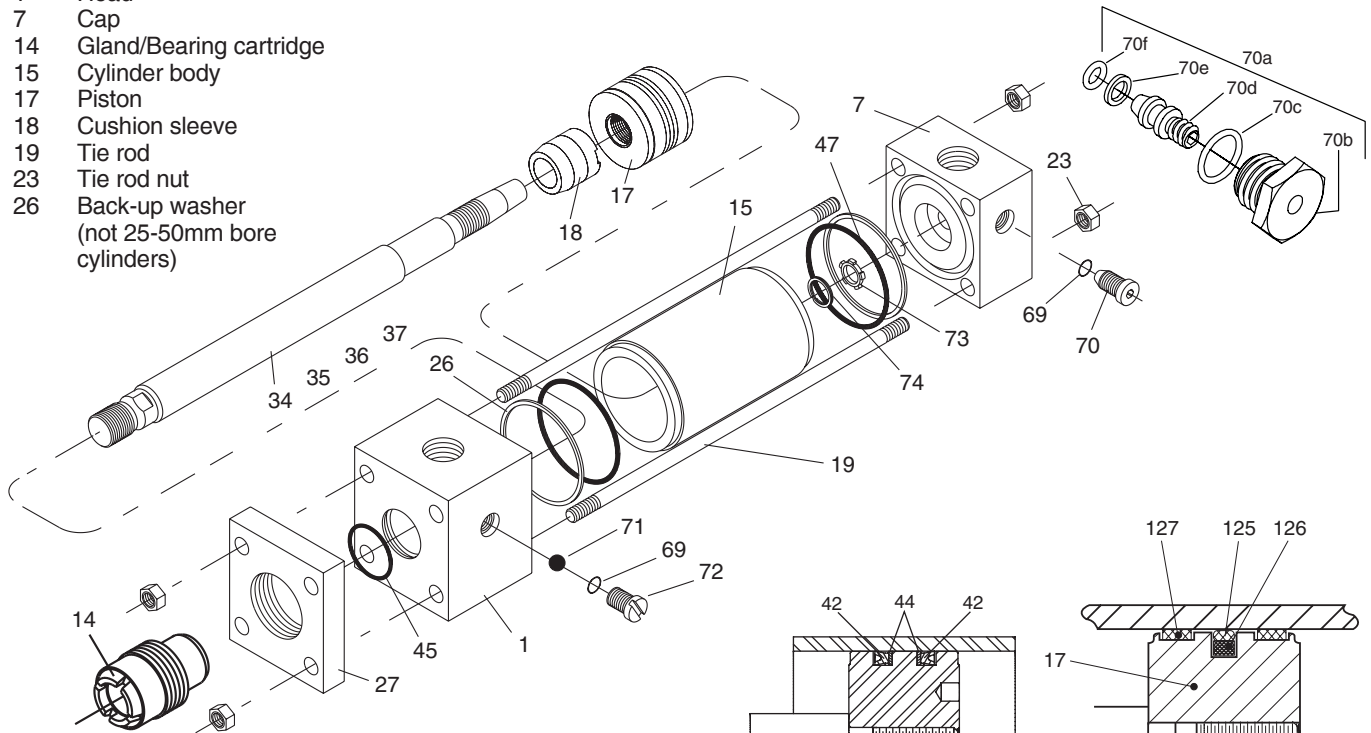

Gland Cartridge and Seals

Contents and Part Numbers of Seal Kits for Piston and Gland

(See key to part numbers opposite)

RG Kit – Gland Cartridge and Seals* Contain items 14, 40, 41, 43, 45. Where the original gland incorporates a gland drain, please consult the factory.

RK Kit – Gland Cartridge Seals* Contain items 40, 41, 43, 45.

Rod Ø	RG Kit*	PK Kit*
12	RG2HM0121	RK2HM0121
14	RG2HM0141	RK2HM0141
18	RG2HM0181	RK2HM0181
22	RG2HM0221	RK2HM0221
28	RG2HM0281	RK2HM0281
36	RG2HM0361	RK2HM0361
45	RG2HM0451	RK2HM0451
56	RG2HM0561	RK2HM0561
70	RG2HM0701	RK2HM0701
90	RG2HM0901	RK2HM0901
110	RG2HM1101	RK2HM1101
140	RG2HM1401	RK2HM1401

CB Kit – Cylinder Body End Seals* Contain two each of items 47, 26 (not 25-50mm bore).

Piston Kit

B-Style Piston Kit – (includes Cylinder Body End Seals) Contains two each of items 47, 26 (no backup washer in 25mm-50mm bores), two of item 127 and one each of items 125, 126.

Lipseal Piston Kit – (includes Cylinder Body End Seals) Contains two each of items 42, 44 and 47.

Bore Ø	CB Body Seal Kit*	B-Style Piston Seal Kit*	Piston Lipseal™ Kit†
25	CB025HM001	PF025HM001	PL025HM005*
32	CB032HM001	PF032HM001	PF032HM005*
40	CB040HM001	PF040HM001	PF040HM005*
50	CB050HM001	PF050HM001	N/A
63	CB063HM001	PF063HM001	
80	CB080HM001	PF080HM001	
100	CB100HM001	PF100HM001	
125	CB125HM001	PF125HM001	
160	CB160HM001	PF160HM001	
200	CB200HM001	PF200HM001	

† Piston Lipseals were made standard in 25mm - 40mm bores beginning in June 2006. Carefully check the model number for a 'B' - B-Style or 'L' - Lipseal Style piston before specifying a piston seal kit.

*Piston Lipseal Kits contain group 5 seals that are also suitable for group 1 service.

***Seal Groups – Ordering**

The part numbers shown in the tables above are for Group 1 seals, denoted by the last character of each part number. For Group 5 seals, substitute a '5' for the '1' at the end of the number sequence.

Piston Lipseal Kits contain Group 5 seals that are also suitable for Group 1 service.

Tie Rod Torques

Bore Ø	Tie Rod Torque Nm
25	4.5-5.0
32	7.6-9.0
40	19.0-20.5
50	68-71
63	68-71
80	160-165
100	160-165
125	450-455
160	815-830
200	1140-1155

Repairs

Although HMI cylinders are designed to make on-site maintenance or repairs as easy as possible, some operations can only be carried out in our factory. It is standard policy to fit a cylinder returned to the factory for repair with those replacement parts which are necessary to return it to 'as good as new' condition. Should the condition of the returned cylinder be such that repair would be uneconomical, you will be notified.

NOTE: For installation instructions for Seal Kits for Series HMI cylinders, see bulletin 0995-M17.

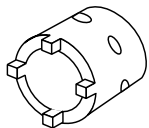
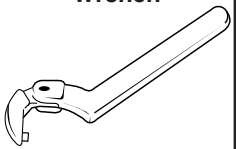
Rod Ø	Gland Cartridge Wrench	Spanner Wrench
		
12	0695900000	0116760000
14	0695900000	0116760000
18	0847650000	0116760000
22	0695910000	0116760000
28	0847660000	0117030000
36	0695920000	0117030000
45	0695930000	0116770000
56	0695950000	0116770000
70	0695960000	0116770000
90	0847680000	0116770000
110	–	–
140	–	–

Mounting Styles

General guidance for the selection of ISO mounting styles can be found on page 4. The notes which follow provide information for use in specific applications and should be read in conjunction with that information.

Trunnions

Trunnions require lubricated pillow blocks with minimum bearing clearances. Blocks should be aligned and mounted to eliminate bending moments on the trunnion pins. Self-aligning mounts must not be used to support the trunnions as bending forces can develop.

Intermediate trunnions may be positioned at any point on the cylinder body. This position, dimension XI, should be specified at the time of order. Trunnion position is not field adjustable.

Flange Mountings

Front flange-mounted (style JJ) cylinders incorporate a pilot diameter for accurate alignment on the mounting surface – see rod end dimensions for HMI cylinders. The gland retainer is integral with the head on 25, 32 and 40mm bore cylinders,

while on 50mm bores and above, the circular retainer is bolted to the head.

Extended Tie Rods

Cylinders may be ordered with extended tie rods in addition to another mounting style. The extended tie rods may then be used for mounting other systems or machine components.

Pivot Mountings

Pivot pins are supplied with style BB cap fixed clevis mounted cylinders. Pivot pins are not supplied with the cap fixed eye mounting, style B, or the cap with spherical bearing, style SB, where pin length will be determined by the customer's equipment.

Spherical Bearings

The service life of a spherical bearing is influenced by such factors as bearing pressure, load direction, sliding velocity and frequency of lubrication. When considering severe or unusual working conditions, please consult the factory.

Foot Mountings and Thrust Keys

The bending moment which results from the application of force by a foot mounted cylinder must be resisted by secure mounting and effective guidance of the load. A thrust key modification is recommended to provide positive cylinder location.

Thrust key mountings eliminate the need for fitted bolts or external keys on Style C side mounted cylinders. The gland retainer plate of 25mm & 32mm bore cylinders is extended below the nominal mounting surface to fit into a keyway milled into the mounting surface of the machine member. To order a key retainer plate in 25mm & 32mm bores, specify P in the Mounting Modification field of the model code.

Cylinders 40mm to 200mm bore utilize a keyway milled into the Style C head on the mounting lug side. A key (supplied) fits into the cylinder keyway and a corresponding keyway in the mounting surface of the machine member. To order the milled keyway and key in 40mm to 200mm bores, specify K in the Mounting Modification field of the model code.

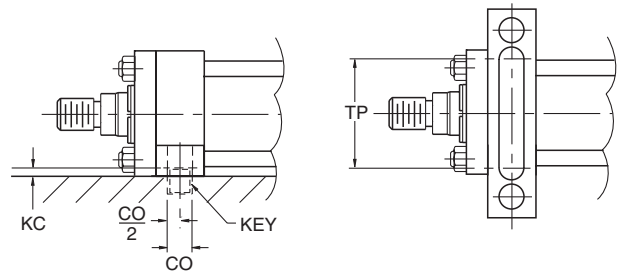

Milled Keyway – 40mm to 200mm Bore

Bore Ø	Rod Ø	Nominal		FA -0.075	GD	PA -0.2
		F1 Standard	F2 w/ Gland Drain			
25	All	10	10 ¹	8	–	5
32	14	10	10 ¹	8	–	5
	22	10	16	8	6	5

¹ Gland drain is in the head. See page 29 for additional details about gland drain ports.

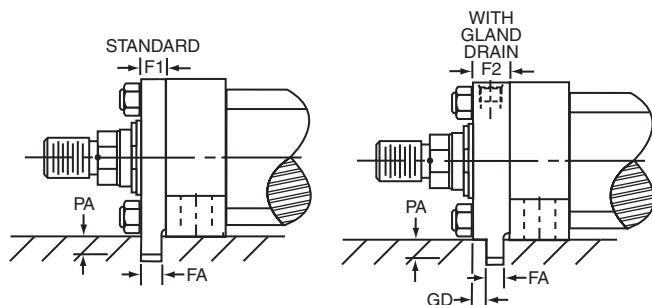

Profile of thrust key extension (with gland drain in retainer) for bore and rod combination 32mm x 22mm.

Integral Key – 25mm & 32mm Bores

All dimensions are in millimeters unless otherwise stated.

Bore Ø	CO N9	KC +0.5	TP ² min
40	12	4	55
50	12	4.5	70
63	16	4.5	80
80	16	5	105
100	16	6	120
125	20	6	155
160	32	8	190
200	40	8	220

² Suggested Key Length

Key				
Bore Ø	Width	Height	Length	Part No.
40	12	8	55	0941540040
50	12	8	70	0941540050
63	16	10	80	0941540063
80	16	10	105	0941540080
100	16	10	120	0941540100
125	20	12	155	0941540125
160	32 ³	18	190	0941540160
200	40	22	220	0941540200

³ Not to ISO6020/2.

Mounting Bolts and Nuts

Parker recommends that mounting bolts with a minimum strength of ISO 898/1 grade 10.9 should be used for fixing cylinders to the machine or base. This recommendation is of particular importance where bolts are placed in tension or subjected to shear forces. Mounting bolts, with lubricated threads, should be torque loaded to their manufacturer's recommended figures. Tie rod mounting nuts should be to a minimum strength of ISO 898/2 grade 10, torque loaded to the figures shown.

Bore Ø	Tie Rod Torque Nm
25	4.5-5.0
32	7.6-9.0
40	19.0-20.5
50	68-71
63	68-71
80	160-165
100	160-165
125	450-455
160	815-830
200	1140-1155

Intermediate or Additional Mountings

Long cylinders with fixed mountings such as extended tie rods may require additional support to counter sagging or the effects of vibration. This may be provided mid-way along the cylinder body in the form of an intermediate mounting or, with end-mounted cylinders, as an additional mounting supporting the free end of the cylinder. Please contact the factory for further information. The maximum unsupported stroke lengths which Parker recommends for each bore size are shown in the table below.

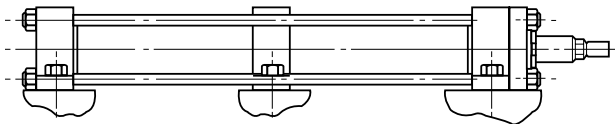

Intermediate Foot Mounting

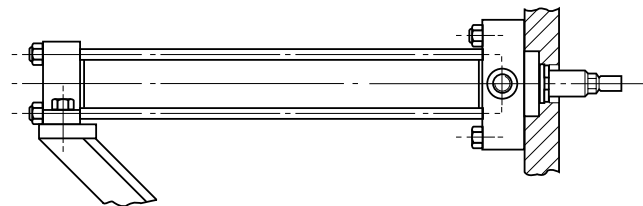

End Support Mounting

Maximum Stroke Lengths of Unsupported Cylinders (in mm)

Bore Ø	Intermediate Mounting	End Support Mounting
25, 32, 40	1500	1000
50, 63, 80	2000	1500
100, 125	3000	2000
160, 200	3500	2500

All dimensions are in millimeters unless otherwise stated.

Tie Rod Supports

To increase the resistance to buckling of long stroke cylinders, tie rod supports may be fitted. These move the tie rods radially outwards and allow longer than normal strokes to be used without the need for an additional mounting.

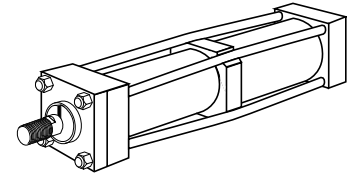

Bore Ø	Stroke (meters)											No. of Supports Required	
	0.9	1.2	1.5	1.8	2.1	2.4	2.7	3.0	3.3	3.6	3.9		4.2
25	1	1	2	Consult Factory									
32	-	1	1	2	Consult Factory								
40	-	-	1	1	1	2	2	2	2	2	3		
50	-	-	-	1	1	1	2	2	2	2	3		
63	-	-	-	-	-	1	1	1	1	1	2	2	
80	-	-	-	-	-	-	-	1	1	1	1	1	
100	-	-	-	-	-	-	-	-	-	1	1	1	

Stroke Tolerances

Stroke length tolerances are required due to the build-up of tolerances of piston, head, cap and cylinder body. Standard production stroke tolerances are 0 to +2mm on all bore sizes and stroke lengths. For closer tolerances, please specify the required tolerance plus the operating temperature and pressure. Stroke tolerances of less than 0.4mm are generally impracticable due to the elasticity of cylinders. In these cases, the use of a stroke adjuster should be considered. Tolerances of stroke dependent dimensions for each mounting style are shown in the table below.

Stroke Dependent Tolerances

Mounting Style	Dimensions	Tolerance - for strokes up to 3m
All styles - port dimensions	Y	±2
	PJ	±1.25
JJ (ME5)	ZB	max
HH (ME6)	ZJ	±1
BB (MP1) B(MP3)	XC	±1.25
SB (MP5)	XO	±1.25
C (MS2)	XS	±2
	ZB	max
	SS	±1.25
D (MT1)	XG	±2
	ZB	max
DB (MT2)	XJ	±1.25
	ZB	max
DD (MT4)	XV	±2
	ZB	max
TD (MX1) TC (MX2) TB (MX3)	BB	+3
TB (MX3)		0
TB (MX3)		max
TD (MX1) TB (MX3)	WH	±2
TD (MX1) TC (MX2) TB (MX3)		ZJ

Calculation of Cylinder Diameter

General Formula

The cylinder output forces are derived from the formula:

$$F = \frac{P \times A}{10000}$$

Where F = Force in kN.

P = Pressure at the cylinder in bar.

A = Effective area of cylinder piston in square mm.

Prior to selecting the cylinder bore size, properly size the piston rod for tension (pull) or compression (push) loading (see the Piston Rod Selection Chart).

If the piston rod is in compression, use the 'Push Force' table below, as follows:

1. Identify the operating pressure closest to that required.
2. In the same column, identify the force required to move the load (always rounding up).
3. In the same row, look along to the cylinder bore required.

If the cylinder envelope dimensions are too large for the application, increase the operating pressure, if possible, and repeat the exercise.

Push Force

Bore Φ mm	Bore Area sq. mm	Cylinder Push Force in kN						
		10 bar	40 bar	63 bar	100 bar	125 bar	160 bar	210 bar
25	491	0.5	2.0	3.1	4.9	6.1	7.9	10.3
32	804	0.8	3.2	5.1	8.0	10.1	12.9	16.9
40	1257	1.3	5.0	7.9	12.6	15.7	20.1	26.4
50	1964	2.0	7.9	12.4	19.6	24.6	31.4	41.2
63	3118	3.1	12.5	19.6	31.2	39.0	49.9	65.5
80	5027	5.0	20.1	31.7	50.3	62.8	80.4	105.6
100	7855	7.9	31.4	49.5	78.6	98.2	125.7	165.0
125	12272	12.3	49.1	77.3	122.7	153.4	196.4	257.7
160	20106	20.1	80.4	126.7	201.1	251.3	321.7	422.2
200	31416	31.4	125.7	197.9	314.2	392.7	502.7	659.7

If the piston rod is in tension, use the 'Deduction for Pull Force' table. The procedure is the same but, due to the reduced area caused by the piston rod, the force available on the 'pull' stroke will be smaller. To determine the pull force:

1. Follow the procedure for 'push' applications as described above.
2. Using the 'pull' table, identify the force indicated according to the rod and pressure selected.
3. Deduct this from the original 'push' force. The resultant is the net force available to move the load.

If this force is not large enough, repeat the process and increase the system operating pressure or cylinder diameter if possible. For assistance, contact your local authorized Parker distributor.

Deduction for Pull Force

Piston Rod Φ mm	Piston Rod Area sq. mm	Reduction in Force in kN						
		10 bar	40 bar	63 bar	100 bar	125 bar	160 bar	210 bar
12	113	0.1	0.5	0.7	1.1	1.4	1.8	2.4
14	154	0.2	0.6	1.0	1.5	1.9	2.5	3.2
18	255	0.3	1.0	1.6	2.6	3.2	4.1	5.4
22	380	0.4	1.5	2.4	3.8	4.8	6.1	8.0
28	616	0.6	2.5	3.9	6.2	7.7	9.9	12.9
36	1018	1.0	4.1	6.4	10.2	12.7	16.3	21.4
45	1591	1.6	6.4	10.0	15.9	19.9	25.5	33.4
56	2463	2.5	9.9	15.6	24.6	30.8	39.4	51.7
70	3849	3.8	15.4	24.2	38.5	48.1	61.6	80.8
90	6363	6.4	25.5	40.1	63.6	79.6	101.8	133.6
110	9505	9.5	38.0	59.9	95.1	118.8	152.1	199.6
140	15396	15.4	61.6	97.0	154.0	192.5	246.3	323.3

Piston Rod Size Selection

To select a piston rod for thrust (push) applications, follow these steps:

1. Determine the type of cylinder mounting style and rod end connection to be used. Consult the Stroke Factor table on page 22 and determine which factor corresponds to the application.
2. Using the appropriate stroke factor from page 22, determine the 'basic length' from the equation:

$$\text{Basic Length} = \text{Net Stroke} \times \text{Stroke Factor}$$

(The graph is prepared for standard rod extensions beyond the face of the gland retainers. For rod extensions greater than standard, add the increases to the net stroke to arrive at the 'basic length'.)

3. Calculate the load imposed for the thrust application by multiplying the full bore area of the cylinder by the system pressure, or by referring to the Push and Pull Force charts on previous page.
4. Using the graph below, look along the values of 'basic length' and 'thrust' as found in 2 and 3 above, and note the point of intersection.

The correct piston rod size is read from the diagonally curved line labelled 'Rod Diameter' above the point of intersection.

Stop Tubes

The required length of stop tube, where necessary, is read from the vertical columns on the right of the graph below by following the horizontal band within which the point of intersection, determined in steps 2 and 3 opposite, lies.

Note that stop tube requirements differ for fixed and pivot mounted cylinders.

If the required length of stop tube is in the region labeled 'consult factory,' please submit the following information:

1. Cylinder mounting style.
2. Rod end connection and method of guiding load.
3. Bore required, stroke, length of rod extension (dimensions WF) if greater than standard.
4. Mounting position of cylinder. (Note: if at an angle or vertical, specify the direction of the piston rod.)
5. Operating pressure of cylinder, if limited to less than the standard pressure for the cylinder selected.

When specifying a cylinder with a stop tube, state the **gross** stroke of the cylinder and the length of the stop tube. The gross stroke is equal to the net (working) stroke of the cylinder plus the stop tube length. See the example below:

Ex. 80-JJ-HMI-R-E-S-14-M1375M1100

- 1) Stop tube = 175
- 2) Net stroke = 1200

– the cylinder net stroke will be 1200mm with 175mm of stop tube.

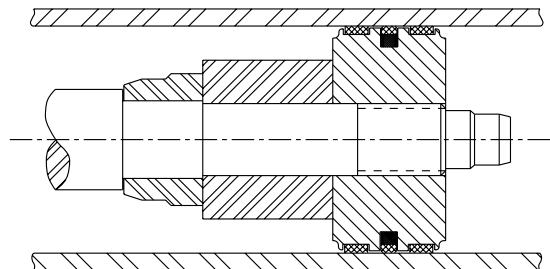

Piston Rod Selection Chart

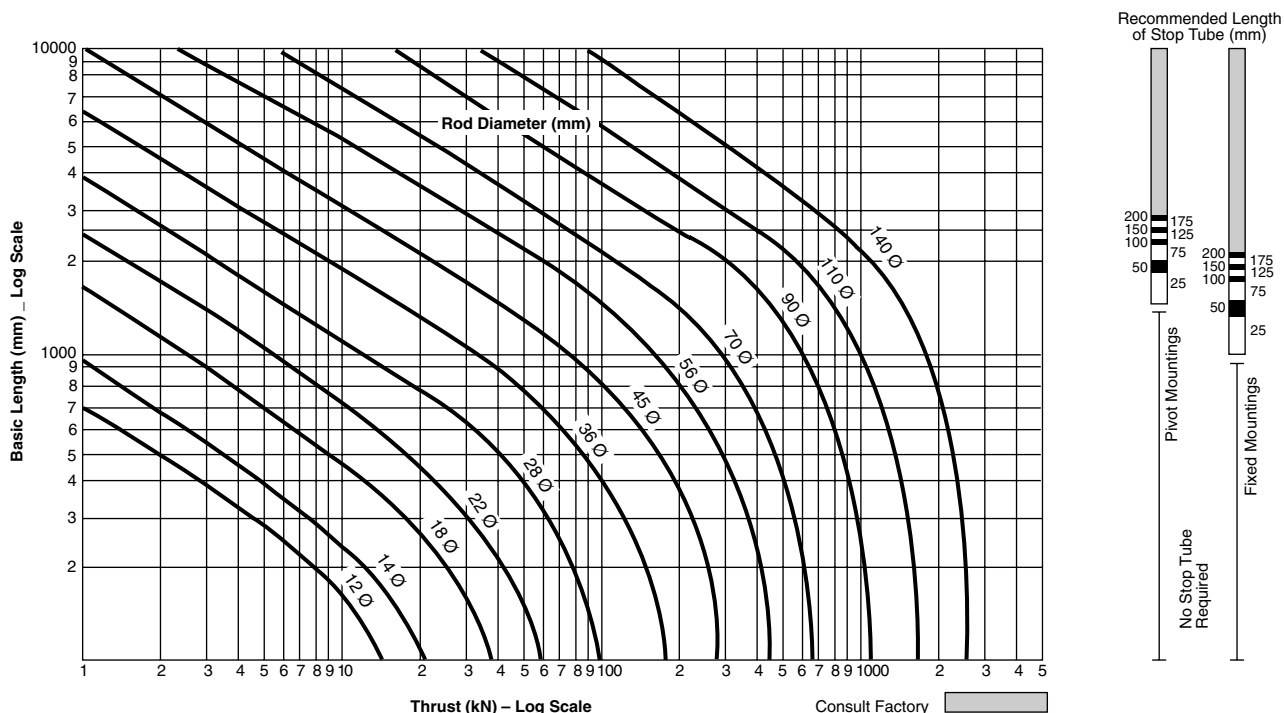

Stroke Factors

The stroke factors below are used in the calculation of cylinder 'basic length' – see Piston Rod Size Selection.

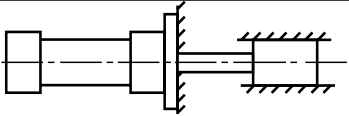
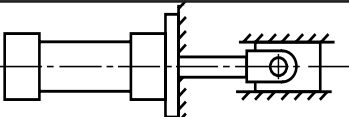
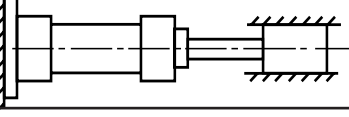
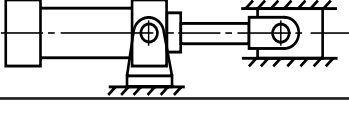
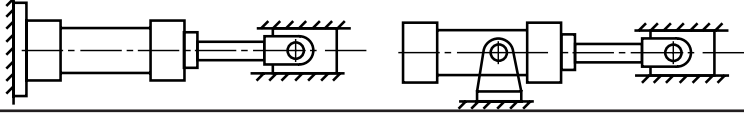
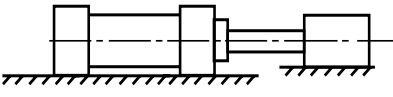
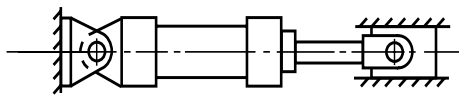
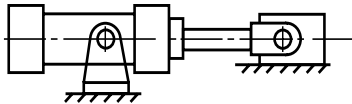
Rod End Connection	Mounting Style	Type of Mounting	Stroke Factor
Fixed and Rigidly Guided	TB, TD, C, JJ		0.5
Pivoted and Rigidly Guided	TB, TD, C, JJ		0.7
Fixed and Rigidly Guided	TC, HH		1.0
Pivoted and Rigidly Guided	D		1.0
Pivoted and Rigidly Guided	TC, HH, DD		1.5
Supported but not Rigidly Guided	TB, TD, C, JJ		2.0
Pivoted and Rigidly Guided	B, BB, DB, SB		2.0
Pivoted and Supported but not Rigidly Guided	DD		3.0

Long Stroke Cylinders

When considering the use of long stroke cylinders, the piston rod should be of sufficient diameter to provide the necessary column strength.

For tensile (pull) loads, the rod size is selected by specifying standard cylinders with standard rod diameters and using them at or below the rated pressure.

For long stroke cylinders under compressive loads, the use of stop tubes should be considered, to reduce bearing stress. The Piston Rod Selection Chart in this catalog provides guidance where unusually long strokes are required.

An Introduction to Cushioning

Cushioning is recommended as a means of controlling the deceleration of masses, or for applications where piston speeds are in excess of 0.1m/s and the piston will make a full stroke. Cushioning extends cylinder life and reduces undesirable noise and hydraulic shock.

Built-in “cushions” are optional and can be supplied at the head and cap ends of the cylinder without affecting its envelope or mounting dimensions.

Standard Cushioning

Ideal cushion performance shows an almost uniform absorption of energy along the cushioning length, as shown. Many forms of cushioning exist, and each has its own specific merits

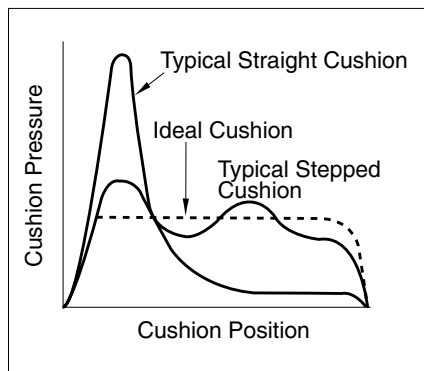

and advantages. In order to cover the majority of applications, HMI cylinders are supplied with profiled cushioning as standard. Final speed may be adjusted using the cushion screws. The performance of profiled cushioning is indicated on the diagram, and cushion performance for

each of the rod sizes available is illustrated graphically in the charts on the next page.

Note: Cushion performance will be affected by the use of water or high water based fluids. Please consult the factory for details.

Cushion Length

Where specified, HMI cylinders incorporate the longest cushion sleeve and spear that can be accommodated within the standard envelope without reducing the rod bearing and piston bearing lengths. See table of cushion lengths on page 25. Cushions are adjustable via recessed needle valves.

Cushion Calculations

The charts on the next page show the energy absorption capacity for each bore/rod combination at the head (annulus) and the cap (full bore) ends of the cylinder. The charts are valid for piston velocities in the range 0.1 to 0.3m/s. For velocities between 0.3 and 0.5m/s, the energy values derived from the charts should be reduced by 25%. For velocities of less than 0.1m/s where large masses are involved, and for velocities of greater than 0.5m/s, a special cushion profile may be required. Please consult the factory for details.

The cushion capacity of the head end is less than that of the cap, and reduces to zero at high drive pressures due to the pressure intensification effect across the piston.

The energy absorption capacity of the cushion decreases with drive pressure.

Formula

Cushioning calculations are based on the formula $E = \frac{1}{2}mv^2$ for horizontal applications. For inclined or vertically downward or upward applications, this is modified to:

$$E = \frac{1}{2}mv^2 + mgl \times 10^{-3} \times \sin a$$

(for inclined or vertically downward direction of mass)

$$E = \frac{1}{2}mv^2 - mgl \times 10^{-3} \times \sin a$$

(for inclined or vertically upward direction of mass)

Where:

- E = energy absorbed in Joules
- g = acceleration due to gravity = 9.81m/s²
- v = velocity in meters/second
- l = length of cushion in millimeters
- m = mass of load in kilograms (including piston, rod and rod end accessories)
- a = angle to the horizontal in degrees
- p = pressure in bar

Example

The following example shows how to calculate the energy developed by masses moving in a straight line. For non-linear motion, other calculations are required; please consult the factory. The example assumes that the bore and rod diameters are already appropriate for the application.

The effects of friction on the cylinder and load have been ignored.

Selected bore/rod 160/70mm (No. 1 rod). Cushioning at the cap end.

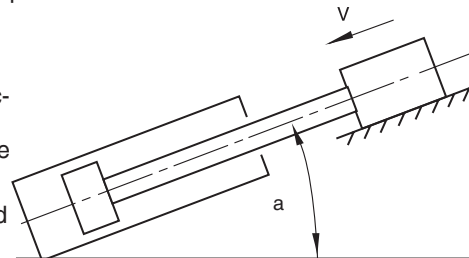

- Pressure = 160 bar
- Mass = 10000kg
- Velocity = 0.4m/s
- Cushion length = 41mm
- a = 45°
- Sin a = 0.70

$$E = \frac{1}{2}mv^2 + mgl \times 10^{-3} \times \sin a$$

$$= \frac{10000 \times 0.4^2}{2} + 10000 \times 9.81 \times \frac{41}{10^3} \times 0.70$$

$$= 800 + 2815 = 3615 \text{ Joules}$$

Note that velocity is greater than 0.3m/s; therefore, a derating factor of 0.75 must be applied before comparison with the curves on the cushioning charts. Applying this factor to the calculated energy figure of 3615 Joules gives a corrected energy figure of:

$$\frac{3615}{0.75} = 4820 \text{ Joules}$$

Comparison with the curve shows that the standard cushion can safely decelerate this load. If the calculated energy exceed that indicated by the curve, select a larger bore cylinder and re-calculate.

Cushion Energy Absorption Capacity Data

The cushion energy absorption capacity data shown below is based on the maximum fatigue-free pressure developed in the tube. For applications with a life cycle of

less than 10^6 cycles, greater energy absorption figures can be applied. Please consult the factory if further information is required.

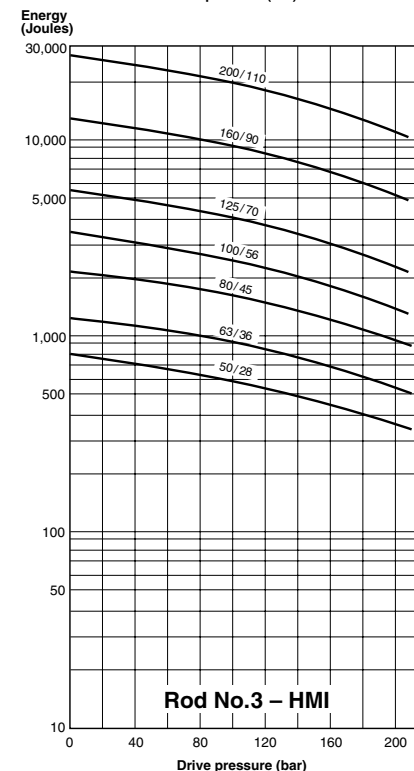
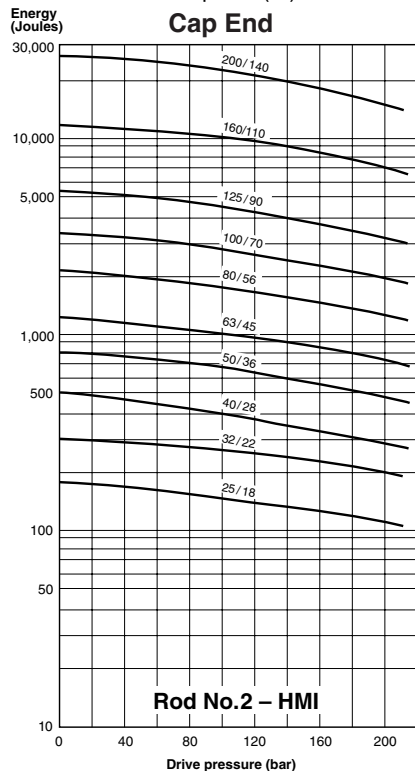
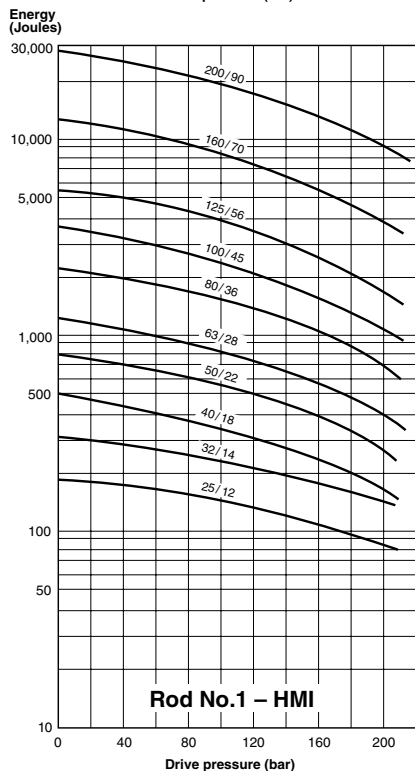
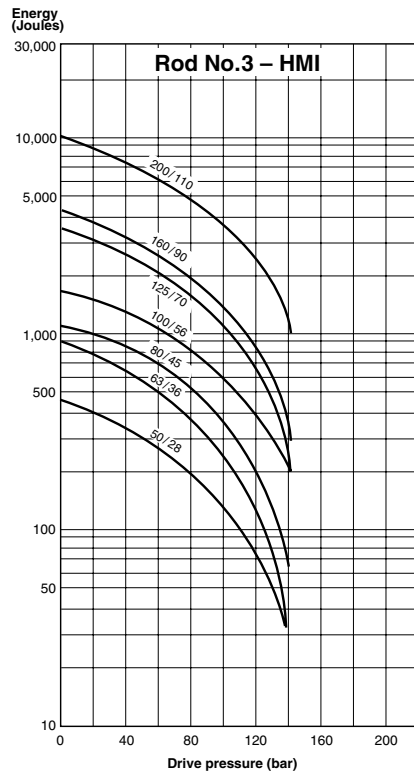
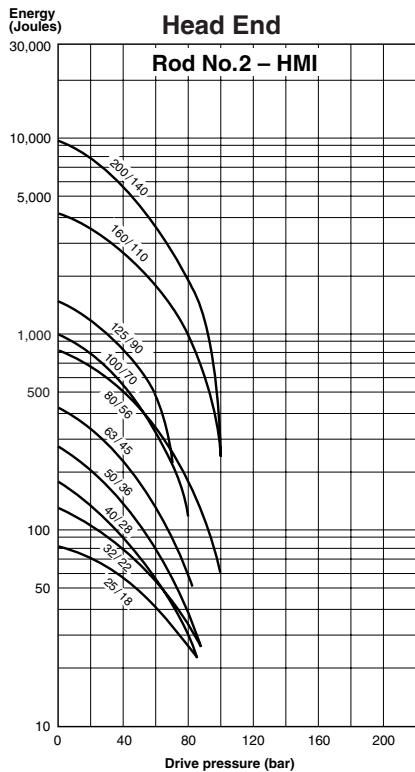
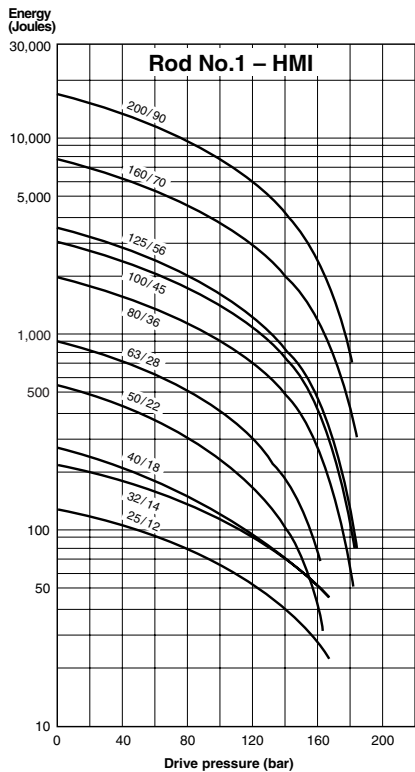

Cushion Length, Piston and Rod Mass

Bore Ø	Rod No.	Rod Ø	Cushion Length - ISO				ISO		Piston & Rod Zero Stroke kg	Rod Only per 10mm Stroke kg
			Rod No. 1		Rod No. 2		Rod No. 3			
			Head	Cap	Head	Cap	Head	Cap		
25	1	12	22	20	24	20	-	-	0.12	0.01
	2	18							0.16	0.02
32	1	14	24	20	24	20	-	-	0.23	0.01
	2	22							0.30	0.03
40	1	18	29	29	29	30	-	-	0.44	0.02
	2	28							0.60	0.05
50	1	22	29	29	29	29	29	29	0.70	0.03
	2	36							0.80	0.05
	3	28							0.95	0.08
63	1	28	29	29	29	29	29	29	1.20	0.05
	2	45							1.35	0.08
	3	36							1.60	0.12
80	1	36	35	32	27	32	35	32	2.30	0.08
	2	56							2.50	0.12
	3	45							2.90	0.19
100	1	45	35	32	26	32	29	32	4.00	0.12
	2	70							4.40	0.19
	3	56							5.10	0.30
125	1	56	28	32	27	32	27	32	7.10	0.19
	2	90							8.00	0.30
	3	70							9.40	0.50
160	1	70	34	41	34	41	34	41	13.70	0.30
	2	110							15.30	0.50
	3	90							17.20	0.75
200	1	90	46	56	49	56	50	56	27.00	0.50
	2	140							30.00	0.75
	3	110							34.00	1.23

Pressure Limitations – Introduction

The pressure limitations of a hydraulic cylinder must be reviewed when considering its application. To assist the designer in obtaining the optimum performance from a cylinder, the information which follows highlights the recommended minimum and maximum pressures according to application. If in doubt, please consult the factory.

Minimum Pressure

Due to factors such as seal friction, the minimum operating pressure for HMI cylinders is 5 bar. Below this pressure, low friction seals should be specified. If in doubt, please consult the factory.

Maximum Pressure

HMI cylinders are designed to the mounting dimensions specified in ISO 6020/2 for 160 bar cylinders but, due to the selection of materials, they can be used at higher pressures depending on the application and the choice of rod size and rod end style. As a result, the majority of these cylinders can be operated at 210 bar.

All dimensions are in millimeters unless otherwise state.

Cylinder Body (Pressure Envelope)

In many applications, the pressure developed within a cylinder may be greater than the working pressure, due to pressure intensification across the piston and cushioning. In most cases, this intensification does not affect the cylinder mountings or piston rod threads in the form of increased loading. It may, however, affect the cylinder body and induce fatigue failure or cause premature seal wear. It is important, therefore, that the pressure due to cushioning or intensification does not exceed the 340 bar fatigue limit of the cylinder body. The cushion energy absorption data on the previous page is based on this maximum induced pressure. If in doubt, please consult the factory.



Ports, Locations and Piston Speeds

Standard Ports

Series HMI cylinders are supplied with BSP parallel threaded ports, of a size suitable for normal speed applications – see table opposite. HMI cylinders are also available with a variety of optional ports.

Oversize Ports

For higher speed applications. Series HMI cylinders are available with oversize BSP or metric ports to the sizes shown in the table opposite, or with extra ports in head or cap faces that are not used for mountings or cushion screws. On 25 mm and 32 mm bore cylinders, 20mm high port bosses are necessary to provide the full thread length at the cap end – see rod end dimensions for increased height at the head end. Note that Y and PJ dimensions may vary slightly to accommodate oversize ports – please contact the factory where these dimensions are critical.

Port Size and Piston Speed

One of the factors which influences the speed of a hydraulic cylinder is fluid flow in the connecting lines. Due to piston rod displacement, the flow at the cap end port will be greater than that at the head end, at the same piston speed. Fluid velocity in connecting lines should be limited to 5m/s to minimize fluid turbulence, pressure loss and hydraulic shock. The tables opposite are a guide for use when determining whether cylinder ports are adequate for the application. Data shown gives piston speeds for standard and oversize ports and connecting lines where the velocity of the fluid is 5m/s.

If the desired piston speed results in a fluid flow in excess of 5 m/s in connecting lines, larger lines with two ports per cap should be considered. Parker recommends that a flow rate of 12 m/s in connecting lines should not be exceeded.

Speed Limitations

Where large masses are involved, or piston speeds exceed 0.1m/s and the piston will make a full stroke, cushions are recommended – see cushion information. For cylinders with oversize ports and with a flow exceeding 8m/s into the cap end, a ‘non-floating cushion’ should be specified. Please consult the factory.

Ports, Air Bleeds and Cushion Adjustment Location

The table below shows standard positions for ports, and cushion adjusting screws where fitted. Air bleeds (see optional features) may be fitted in unoccupied faces of the head or cap, depending on mounting.

Bore Ø	Standard Cylinder Ports				
	Port Size BSP/G Inches	Port Size Metric ¹	Bore of Connecting Lines	Cap End Flow in l/min @ 5m/s	Piston Speed m/s
25	1/4	M14x1.5	7	11.5	0.39
32	1/4	M14x1.5	7	11.5	0.24
40	3/8	M18x1.5	10	23.5	0.31
50	1/2	M22x1.5	13	40	0.34
63	1/2	M22x1.5	13	40	0.21
80	3/4	M27x2	15	53	0.18
100	3/4	M27x2	15	53	0.11
125	1	M33x2	19	85	0.12
160	1	M33x2	19	85	0.07
200	1 1/4	M42x2	24	136	0.07

Bore Ø	Oversize Cylinder Ports (Not to DIN)				
	Port Size BSP/G Inches	Port Size Metric ¹	Bore of Connecting Lines	Cap End Flow in l/min @ 5m/s	Piston Speed m/s
25	3/8 ²	M18x1.5 ^{2,3}	10	23.5	0.80
32	3/8 ²	M18x1.5 ^{2,3}	10	23.5	0.48
40	1/2	M22x1.5 ³	13	40	0.53
50	3/4	M27x2 ³	15	53	0.45
63	3/4	M27x2 ³	15	53	0.28
80 ⁴	1	M33x2	19	85	0.28
100 ⁴	1	M33x2	19	85	0.18
125 ⁴	1 1/4	M42x2	24	136	0.18
160 ⁴	1 1/4	M42x2	24	136	0.11
200 ⁴	1 1/2	M48x2	30	212	0.11

¹Not to DIN 24 554

²20mm high port bosses fitted at cap end

³ISO 6149 ports are not available on some bore/rod combinations

⁴Consult factory – not normally available on these bore sizes

Not recommended for JJ mountings at pressures above 100 bar

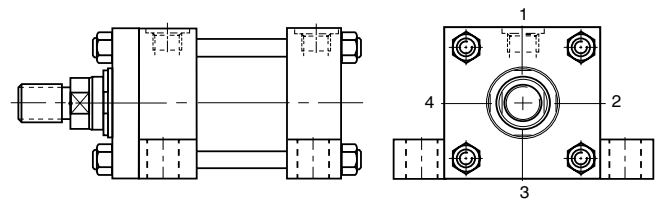

Ports at position 2 or 4 in 25mm to 100mm bore sizes of mounting style C are offset toward position 1 and are not available in the head of 25mm and 32mm bores with number 2 rods. 25mm and 32mm bore heads will not be elongated 5mm toward position 2 or 4 when a port is specified at either of those two locations (the 5mm elongation at position 1 will remain). Contact the factory for the offset dimension.

Positions of Ports and Cushion Screws in Head and Cap		Mounting Styles																																	
		TB, TC and TD				JJ				HH				C ⁵				B and BB				SB				D				DB				DD	
Head	Port	1	2	3	4	1	2	3	4	1	2	3	4	1	2	4	1	2	3	4	1	2	3	4	1	3	1	2	3	4	1	2	3	4	
	Cushion	2	3	4	1	3	3	1	1	3	4	1	2	2	4	2	2	3	4	1	2	3	4	1	3	1	3	4	1	2	3	4	1	2	
Cap	Port	1	2	3	4	1	2	3	4	1	2	3	4	1	2	4	1	2	3	4	1	2	3	4	1	2	3	4	1	3	1	2	3	4	
	Cushion	2	3	4	1	3	4	1	2	3	3	1	1	2	4	2	2	3	4	1	2	3	4	1	3	4	1	2	3	1	3	4	1	2	

⁵Ports at position 2 or 4 in 25mm to 100mm bores are offset toward position 1.

All dimensions are in millimeters unless otherwise stated.



Cylinder Port Options

- Option "T" SAE Straight Thread O-Ring Port. Recommended for most hydraulic applications.
- Option "U" Conventional NPTF Ports (Dry-Seal Pipe Threads). Recommended for pneumatic applications only.
- Option "R" BSPP Port (British Parallel Thread). ISO 228 port commonly used in Europe. See Figure R-G below.
- Option "P" SAE Flange Ports Code 61 (3000 psi). Recommended for hydraulic applications requiring larger port sizes.
- Option "B" BSPT (British Tapered Thread).
- Option "M" Metric Straight Thread Port similar to Option "R" with metric thread. Popular in some European applications. See Figure R-G below.
- Option "Y" ISO-6149-1 Metric Straight Thread Port. Recommended for all hydraulic applications designed per ISO standards. See Figure Y below.

Bore Ø	"T" SAE	"U" NPTF Pipe Thread	"R" BSPP Parallel Thread (Standard)	"P" SAE 4-Bolt Flange Nom. Size	"B" BSPT Taper Thread	"M" Metric Straight Thread	"Y" ISO-6149-1 Metric Straight Thread
25	#6	1/4	1/4	N/A	1/4	M14 x 1.5	M14 x 1.5
32	#6	1/4	1/4	N/A	1/4	M14 x 1.5	M14 x 1.5
40	#6	3/8	3/8	N/A	3/8	M18 x 1.5	M18 x 1.5
50	#10	1/2	1/2	N/A	1/2	M22 x 1.5	M22 x 1.5
63	#10	1/2	1/2	1/2	1/2	M22 x 1.5	M22 x 1.5
80	#12	3/4	3/4	3/4	3/4	M27 x 2	M27 x 2
100	#12	3/4	3/4	3/4	3/4	M27 x 2	M27 x 2
125	#16	1	1	1	1	M33 x 2	M33 x 2
160	#16	1	1	1	1	M33 x 2	M33 x 2
200	#20	1 1/4	1 1/4	1 1/4	1 1/4	M42 x 2	M42 x 2

BSPP Port for Series HMI

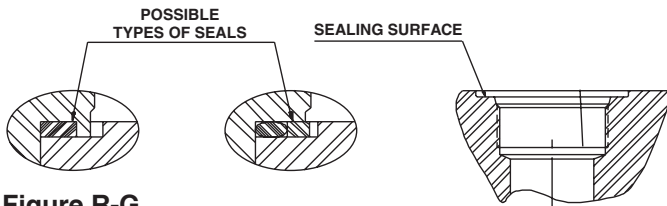

Figure R-G

ISO 6149-1 Port for Series HMI

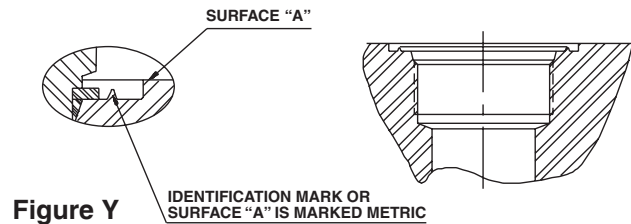

Figure Y

Weights – Series HMI Cylinders

Bore Ø	Rod Ø	Mounting Styles – Weight at Zero Stroke						Weight per 10mm Stroke kg
		TB, TC TD	C	JJ, HH	B,BB, SB	D, DB	DD	
25	12	1.2	1.4	1.5	1.4	1.3	1.5	0.05
	18						1.6	0.06
32	14	1.6	1.9	2.0	1.9	1.7	2.0	0.06
	22						1.7	0.08
40	18	3.7	4.0	4.7	4.2	3.9	4.6	0.09
	28						3.8	4.1
50	22	5.9	6.5	7.2	7.0	6.3	7.9	0.14
	28						6.0	6.6
36	6.0	6.6	7.3	7.2	6.4	8.0		
63	28	8.5	9.7	10.1	10.1	8.9	10.6	0.19
	36	8.6	9.8	10.2	10.2	9.0	10.7	0.22
	45	8.7	9.9	10.3	10.4	9.1	10.9	0.27
80	36	16.0	17.3	18.9	19.5	16.5	20.5	0.27
	45	16.1	17.4	19.0	19.6	16.6		0.32
	56	16.3	17.7	19.2	19.8	16.8	20.7	0.39

Bore Ø	Rod Ø	Mounting Styles – Weight at Zero Stroke						Weight per 10mm Stroke kg		
		TB, TC TD	C	JJ, HH	B,BB, SB	D, DB	DD			
100	45	22.0	24.0	25.0	28.0	22.7	26.0	0.40		
	56			26.0			27.0	0.47		
	70			23.0			25.0	29.0	23.2	27.0
125	56	42.0	44.0	48.0	53.0	43.0	48.0	0.65		
	70			45.0			54.0	49.0	49.0	0.76
	90								43.0	49.0
160	70	69.0	73.0	78.0	90.0	71.0	84.0	1.00		
	90			78.0			91.0	72.0	85.0	1.20
	110									70.0
200	90	122.0	129.0	138.0	157.0	127.0	153.0	1.50		
	110	123.0	130.0		158.0	128.0		1.80		
	140	124.0	131.0	140.0	160.0	129.0	155.0	2.30		

All dimensions are in millimeters unless otherwise stated.



Seals and Fluid Data

Group	Seal Materials – a combination of:	Fluid Medium to ISO 6743/4-1982	Temperature Range
1	Nitrile (NBR), PTFE, enhanced polyurethane (AU)	Mineral oil HH, HL, HLP, HLP-D, HM, HV, MIL-H-5606 oil, nitrogen	-20°C to + 80°C
5	Fluorocarbon elastomer (FPM) Fluorocarbon, PTFE	Fire resistant fluids based on phosphate esters (HFD-R) Also suitable for hydraulic oil at high temperatures/environments. Not suitable for use with Skydrol. See fluid manufacturer's recommendations.	-20°C to + 150°C

Operating Medium

Sealing materials used in the standard cylinder are suitable for use with most petroleum-based hydraulic fluids.

Special seals are available for use with water-glycol or water-in-oil emulsions, and with fluids such as fire-resistant synthetic phosphate ester and phosphate ester-based fluids.

If there is any doubt regarding seal compatibility with the operating medium, please consult the factory.

The table above is a guide to the sealing compounds and operating parameters of the materials used for standard and optional rod gland, piston and body seals

Temperature

Standard seals can be operated at temperatures between -20°C and +80°C. Where operating conditions result in temperatures which exceed these limits, special seal compounds may be required to ensure satisfactory service life – please consult the factory.

Special Seals

Group 1 seals are fitted as standard to HMI cylinders. For other duties, the optional seal group 5 is available – please see the cylinder order code for HMI (ISO) cylinders. Special seals, in addition to those shown in the table above, can also be supplied. Please insert an S (Special) in the order code and specify fluid medium when ordering.

Water Service

Special cylinders are available for use with water as the fluid medium. Modifications include a stainless steel piston rod with lipseal piston, and plating of internal surfaces. When ordering, please specify the maximum operating pressure or load/speed conditions.

Warranty

Parker Hannifin warrants cylinders modified for use with water or water base fluids to be free of defects in materials and workmanship, but cannot accept responsibility for premature failure caused by corrosion, electrolysis or mineral deposits in the cylinder.

Low Friction Seals

For applications where very low friction and an absence of stick-slip are important, the option of low friction seals is available. Please consult the factory.

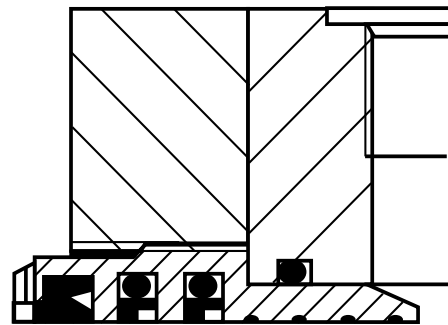

Metallic Rod Wipers

Metallic rod wipers replace the standard wiper seal, and are recommended where dust or splashings might damage the wiper seal material. Metallic rod wipers do not affect cylinder dimensions.

Proximity Sensors

EPS proximity switches can be fitted to give reliable end of stroke signals.

Position Feedback

Linear position transducers of various types are available for Series HMI cylinders. Please contact the factory for further details.

Rod End Bellows

Unprotected piston rod surfaces which are exposed to contaminants with air hardening properties can be protected by rod end bellows. Longer rod extensions are required to accommodate the collapsed length of the bellows. Please consult the factory for further information.

Gland Drains

The tendency of hydraulic fluid to adhere to the piston rod can result in an accumulation of fluid in the cavity behind the gland wiperseal under certain operating conditions. This may occur with long stroke cylinders; where there is a constant back pressure as in differential circuitry, or where the ratio of the extend speed to the retract speed is greater than 2 to 1.

A gland drain port is provided in the retainer, except in mounting style JJ, style D in 100mm to 200mm bores, and regardless of mounting style, 25mm bore with all rod numbers, and 32mm to 40mm bores with number 1 rod. In these cases the drain port is located in the head. When the gland drain port in 25mm to 40mm bores is in the head of all mounting styles except JJ, it must be in the same position as the port (on the 5mm elongated side for 25mm & 32mm bores) and when specified in 25mm and 32mm bores of mounting style C it must be in position 1. On JJ mounting styles in 25mm and 32mm bores the drain port can be in position 2 or 4 and is not available in position 3. When the gland drain port is provided in the retainer, the thickness of the retainer is increased by 6mm in 32mm and 40mm bores with number 2 rod and by 4mm in 63mm bore cylinders with number 2 rod. Note that, on style JJ cylinders, drain ports cannot normally be positioned in the same face as ports or cushion valves – please consult the factory.

Gland Drain Port Location & Position Availability

Bore Ø	Rod Ø	Head (H) or Retainer (R) Location / Position			
		TB, TC, TD, HH, B, BB, SB, DB, DD	C	D	JJ
25	All	H / 1, 2, 3, 4	H / 1	H / 1, 3	H / 2, 4
32	14	H / 1, 2, 3, 4	H / 1	H / 1, 3	H / 2, 4
	22	R / 1, 2, 3, 4	R / 1, 2, 3 ¹ , 4	R / 1, 2, 3, 4	H / 2, 4
40	18	H / 1, 2, 3, 4	H / 1	H / 1, 3	H / 2, 3, 4
	28	R / 1, 2, 3, 4	R / 1, 2, 3, 4	R / 1, 2, 3, 4	H / 2, 3, 4
50	All	R / 1, 2, 3, 4	R / 1, 2, 3, 4	R / 1, 2, 3, 4	H / 2, 3, 4
63	All	R / 1, 2, 3, 4	R / 1, 2, 3, 4	R / 1, 2, 3, 4	H / 2, 3, 4
80	All	R / 1, 2, 3, 4	R / 1, 2, 3, 4	R / 1, 2, 3, 4	H / 2, 3, 4
100	All	R / 1, 2, 3, 4	R / 1, 2, 3, 4	H / 1, 3	H / 2, 3, 4
125	All	R / 1, 2, 3, 4	R / 1, 2, 3, 4	H / 1, 3	H / 2, 3, 4
160	All	R / 1, 2, 3, 4	R / 1, 2, 3, 4	H / 1, 3	H / 2, 3, 4
200	All	R / 1, 2, 3, 4	R / 1, 2, 3, 4	H / 1, 3	H / 2, 3, 4

¹ Gland drain is not available in position 3 when key plate is specified.

Gland drain ports will be the same type as the ports specified on the cylinder assembly except for non “JJ” mounts on bore sizes 25, 32, 40 and 50 mm. In these cases they will be 1/8 NPTF.

The size of the gland drain ports are as shown on the adjacent table.

Gland drains should be piped back to the fluid reservoir, which should be located below the level of the cylinder.

Port Type	Port Size
R (BSPP)	1/8 BSPP
T (SAE)	#4 (SAE)
U (Pipe Thread)	1/8 NPTF
M (Metric Straight)	M10 x 1
Y (ISO 6149-1)	M10 x 1
B (BSPT)	1/8 BSPT
P (SAE 4 Bolt Flange)	1/8 BSPP

Air Bleeds

The option of bleed screws is available at either or both ends of the cylinder, at any position except in the port face. The selected positions should be shown in the order code. Cylinders with bore sizes up to 40mm are fitted with M5 bleed screws; for bore sizes of 50mm and above, M8 bleed screws are fitted. Note that, for cylinders of 50mm bore and above, where it is essential to have the air bleed in the port face, bosses can be welded to the cylinder tube. Please contact the factory for details.

Spring-Returned, Single-Acting Cylinders

Series HMI single-acting cylinders can be supplied with an internal spring to return the piston after the pressure stroke. Please supply details of load conditions and friction factors, and advise whether the spring is required to advance or return the piston rod.

On spring-returned cylinders, tie rod extensions will be supplied to allow the spring to be ‘backed off’ until compression is relieved. Tie rod nuts will be welded to the tie rods at the opposite end of the cylinder, to further assure safe disassembly. Please contact the factory when ordering spring-returned cylinders.

Duplex and Tandem Cylinders

A tandem cylinder is made up of two cylinders mounted in line with pistons connected by a common piston rod and rod seals installed between the cylinders to permit double acting operation of each. Tandem cylinders allow increased output force when mounting width or height are restricted.

A duplex cylinder is made up of two cylinders mounted in line with pistons not connected with rod seals installed between the cylinders to permit double acting operation of each. Cylinders may be mounted with piston rod to piston or back to back and are generally used to provide three position operation.

Stroke Adjusters

Where absolute precision in stroke length is required, a screwed adjustable stop can be supplied. Several types are available – the illustration shows a design suitable for infrequent² adjustment at the uncushioned cap end of a cylinder. Please contact the factory, specifying details of the application and the adjustment required.

Bore Ø	D	J	K min	L max
40	M12x1.25	7	75	130
50	M20x1.5	12	75	200
63	M27x2	16	75	230
80	M33x2	20	85	230
100	M42x2	26	70	450
125	M48x2	30	70	500
160	M64x3	40	75	500
200	M80x3	50	80	500

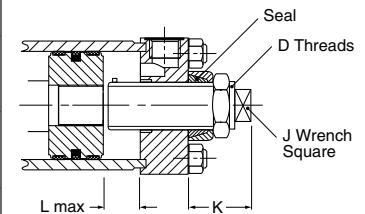

All dimensions are in millimeters unless otherwise stated.

² Infrequent is defined by positioning the retract stroke in a couple of attempts at original machine set up. The frequent stroke adjuster is recommended for adjustments required after the original equipment has been adjusted by the original machine manufacturer.

Safety Guide for Selecting and Using Hydraulic, Pneumatic Cylinders and Their Accessories

WARNING: ⚠ **FAILURE OF THE CYLINDER, ITS PARTS, ITS MOUNTING, ITS CONNECTIONS TO OTHER OBJECTS, OR ITS CONTROLS CAN RESULT IN:**

- Unanticipated or uncontrolled movement of the cylinder or objects connected to it.
- Falling of the cylinder or objects held up by it.
- Fluid escaping from the cylinder, potentially at high velocity.

THESE EVENTS COULD CAUSE DEATH OR PERSONAL INJURY BY, FOR EXAMPLE, PERSONS FALLING FROM HIGH LOCATIONS, BEING CRUSHED OR STRUCK BY HEAVY OR FAST MOVING OBJECTS, BEING PUSHED INTO DANGEROUS EQUIPMENT OR SITUATIONS, OR SLIPPING ON ESCAPED FLUID.

Before selecting or using Parker Hannifin Corporation (the Company) cylinders or related accessories, it is important that you read, understand and follow the following safety information. Training is advised before selecting and using the Company's products.

1.0 General Instructions

1.1 Scope – This safety guide provides instructions for selecting and using (including assembling, installing, and maintaining) cylinder products. This safety guide is a supplement to and is to be used with the specific Company publications for the specific cylinder products that are being considered for use.

1.2 Fail Safe – Cylinder products can and do fail without warning for many reasons. All systems and equipment should be designed in a fail-safe mode so that if the failure of a cylinder product occurs people and property won't be endangered.

1.3 Distribution – Provide a free copy of this safety guide to each person responsible for selecting or using cylinder products. Do not select or use the Company's cylinders without thoroughly reading and understanding this safety guide as well as the specific Company publications for the products considered or selected.

1.4 User Responsibility – Due to very wide variety of cylinder applications and cylinder operating conditions, the Company does not warrant that any particular cylinder is suitable for any specific application. This safety guide does not analyze all technical parameters that must be considered in selecting a product. The hydraulic and pneumatic cylinders outlined in this catalog are designed to the Company's design guidelines and do not necessarily meet the design guideline of other agencies such as American Bureau of Shipping, ASME Pressure Vessel Code etc. The user, through its own analysis and testing, is solely responsible for:

- Making the final selection of the cylinders and related accessories.
- Determining if the cylinders are required to meet specific design requirements as required by the Agency(s) or industry standards covering the design of the user's equipment.
- Assuring that the user's requirements are met, OSHA requirements are met, and safety guidelines from the applicable agencies such as but not limited to ANSI are followed and that the use presents no health or safety hazards.
- Providing all appropriate health and safety warnings on the equipment on which the cylinders are used.

1.5 Additional Questions – Call the appropriate Company technical service department if you have any questions or require any additional information. See the Company publication for the product being considered or used, or call 1-847-298-2400, or go to www.parker.com, for telephone numbers of the appropriate technical service department.

2.0 Cylinder and Accessories Selection

2.1 Seals – Part of the process of selecting a cylinder is the selection of seal compounds. Before making this selection, consult the "seal information page(s)" of the publication for the series of cylinders of interest.

The application of cylinders may allow fluids such as cutting fluids, wash down fluids etc. to come in contact with the external area of the cylinder. These fluids may attack the piston rod wiper and or the primary seal and must be taken into account when selecting and specifying seal compounds.

Dynamic seals will wear. The rate of wear will depend on many operating factors. Wear can be rapid if a cylinder is mis-aligned or if the cylinder has been improperly serviced. The user must take seal wear into consideration in the application of cylinders.

2.2 Piston Rods – Possible consequences of piston rod failure or separation of the piston rod from the piston include, but are not limited to are:

- Piston rod and or attached load thrown off at high speed.
- High velocity fluid discharge.
- Piston rod extending when pressure is applied in the piston retract mode.

Piston rods or machine members attached to the piston rod may move suddenly and without warning as a consequence of other conditions occurring to the machine such as, but not limited to:

- Unexpected detachment of the machine member from the piston rod.

- Failure of the pressurized fluid delivery system (hoses, fittings, valves, pumps, compressors) which maintain cylinder position.
- Catastrophic cylinder seal failure leading to sudden loss of pressurized fluid.
- Failure of the machine control system.

Follow the recommendations of the "Piston Rod Selection Chart and Data" in the publication for the series of cylinders of interest. The suggested piston rod diameter in these charts must be followed in order to avoid piston rod buckling.

Piston rods are not normally designed to absorb bending moments or loads which are perpendicular to the axis of piston rod motion. These additional loads can cause the piston rod to fail. If these types of additional loads are expected to be imposed on the piston rod, their magnitude should be made known to our engineering department.

The cylinder user should always make sure that the piston rod is securely attached to the machine member.

On occasion cylinders are ordered with double rods (a piston rod extended from both ends of the cylinder). In some cases a stop is threaded on to one of the piston rods and used as an external stroke adjuster. On occasions spacers are attached to the machine member connected to the piston rod and also used as a stroke adjuster. In both cases the stops will create a pinch point and the user should consider appropriate use of guards. If these external stops are not perpendicular to the mating contact surface, or if debris is trapped between the contact surfaces, a bending moment will be placed on the piston rod, which can lead to piston rod failure. An external stop will also negate the effect of cushioning and will subject the piston rod to impact loading. Those two (2) conditions can cause piston rod failure. Internal stroke adjusters are available with and without cushions. The use of external stroke adjusters should be reviewed with our engineering department.

The piston rod to piston and the stud to piston rod threaded connections are secured with an anaerobic adhesive. The strength of the adhesive decreases with increasing temperature. Cylinders which can be exposed to temperatures above +250°F (+121°C) are to be ordered with a non studded piston rod and a pinned piston to rod joint.

2.3 Cushions – Cushions should be considered for cylinder applications when the piston velocity is expected to be over 4 inches/second.

Cylinder cushions are normally designed to absorb the energy of a linear applied load. A rotating mass has considerably more energy than the same mass moving in a linear mode. Cushioning for a rotating mass application should be reviewed by our engineering department.

2.4 Cylinder Mountings – Some cylinder mounting configurations may have certain limitations such as but not limited to minimum stroke for side or foot mounting cylinders or pressure de-ratings for certain mounts. Carefully review the catalog for these types of restrictions.

Always mount cylinders using the largest possible high tensile alloy steel socket head cap screws that can fit in the cylinder mounting holes and torque them to the manufacturer's recommendations for their size.

2.5 Port Fittings – Hydraulic cylinders applied with meter out or deceleration circuits are subject to intensified pressure at piston rod end.

The rod end pressure is approximately equal to:

$$\frac{\text{operating pressure} \times \text{effective cap end area}}{\text{effective rod end piston area}}$$

Contact your connector supplier for the pressure rating of individual connectors.

3.0 Cylinder and Accessories Installation and Mounting

3.1 Installation

3.1.1 – Cleanliness is an important consideration, and cylinders are shipped with the ports plugged to protect them from contaminants entering the ports. These plugs should not be removed until the piping is to be installed. Before making the connection to the cylinder ports, piping should be thoroughly cleaned to remove all chips or burrs which might have resulted from threading or flaring operations.

3.1.2 – Cylinders operating in an environment where air drying materials are present such as fast-drying chemicals, paint, or weld splatter, or other hazardous conditions such as excessive heat, should have shields installed to prevent damage to the piston rod and piston rod seals.

3.1.3 – Proper alignment of the cylinder piston rod and its mating component on the machine should be checked in both the extended and retracted positions. Improper alignment will result in excessive rod gland and/or cylinder bore wear. On fixed mounting cylinders attaching the piston rod while the rod is retracted will help in achieving proper alignment.

3.1.4 – Sometimes it may be necessary to rotate the piston rod in order to thread the piston rod into the machine member. This operation must always be done with zero pressure being applied to either side of the piston. Failure to follow this procedure may result in loosening the piston to rod-threaded connection. In some rare cases the turning of the piston rod may rotate a threaded piston rod gland and loosen it from the cylinder head. Confirm that this condition is not occurring. If it does, re-tighten the piston rod gland firmly against the cylinder head.

For double rod cylinders it is also important that when attaching or detaching the piston rod from the machine member that the torque be applied to the piston rod end of the cylinder that is directly attaching to the machine member with the opposite end unrestrained. If the design of the machine is such that only the rod end of the cylinder opposite to where the rod attaches to the machine member can be rotated, consult the factory for further instructions.

3.2 Mounting Recommendations

3.2.1 – Always mount cylinders using the largest possible high tensile alloy steel socket head screws that can fit in the cylinder mounting holes and torque them to the manufacturer's recommendations for their size.

3.2.2 – Side-Mounted Cylinders – In addition to the mounting bolts, cylinders of this type should be equipped with thrust keys or dowel pins located so as to resist the major load.

3.2.3 – Tie Rod Mounting – Cylinders with tie rod mountings are recommended for applications where mounting space is limited. The standard tie rod extension is shown as BB in dimension tables. Longer or shorter extensions can be supplied. Nuts used for this mounting style should be torqued to the same value as the tie rods for that bore size.

3.2.4 – Flange Mount Cylinders – The controlled diameter of the rod gland extension on head end flange mount cylinders can be used as a pilot to locate the cylinders in relation to the machine. After alignment has been obtained, the flanges may be drilled for pins or dowels to prevent shifting.

3.2.5 – Trunnion Mountings – Cylinders require lubricated bearing blocks with minimum bearing clearances. Bearing blocks should be carefully aligned and rigidly mounted so the trunnions will not be subjected to bending moments. The rod end should also be pivoted with the pivot pin in line and parallel to axis of the trunnion pins.

3.2.6 – Clevis Mountings – Cylinders should be pivoted at both ends with centerline of pins parallel to each other. After cylinder is mounted, be sure to check to assure that the cylinder is free to swing through its working arc without interference from other machine parts.

4.0 Cylinder and Accessories Maintenance, Troubleshooting and Replacement

4.1 Storage – At times cylinders are delivered before a customer is ready to install them and must be stored for a period of time. When storage is required the following procedures are recommended.

4.1.1 – Store the cylinders in an indoor area which has a dry, clean and noncorrosive atmosphere. Take care to protect the cylinder from both internal corrosion and external damage.

4.1.2 – Whenever possible cylinders should be stored in a vertical position (piston rod up). This will minimize corrosion due to possible condensation which could occur inside the cylinder. This will also minimize seal damage.

4.1.3 – Port protector plugs should be left in the cylinder until the time of installation.

4.1.4 – If a cylinder is stored full of hydraulic fluid, expansion of the fluid due to temperature changes must be considered. Installing a check valve with free flow out of the cylinder is one method.

4.1.5 – When cylinders are mounted on equipment that is stored outside for extended periods, exposed unpainted surfaces, e.g. piston rod, must be coated with a rust-inhibiting compound to prevent corrosion.

4.2 Cylinder Trouble Shooting

4.2.1 – External Leakage

4.2.1.1 – Rod seal leakage can generally be traced to worn or damaged seals. Examine the piston rod for dents, gouges or score marks, and replace piston rod if surface is rough.

Rod seal leakage could also be traced to gland wear. If clearance is excessive, replace rod bushing and seal. Rod seal leakage can also be traced to seal deterioration. If seals are soft or gummy or brittle, check compatibility of seal material with lubricant used if air cylinder, or operating fluid if hydraulic cylinder. Replace with seal material, which is compatible with these fluids. If the seals are hard or have lost elasticity, it is usually due to exposure to temperatures in excess of 165°F. (+74°C). Shield the cylinder from the heat source to limit temperature to 350°F. (+177°C.) and replace with fluorocarbon seals.

4.2.1.2 – Cylinder body seal leak can generally be traced to loose tie rods. Torque the tie rods to manufacturer's recommendation for that bore size.

Excessive pressure can also result in cylinder body seal leak. Determine maximum pressure to rated limits. Replace seals and retorque tie rods as in paragraph above. Excessive pressure can also result in cylinder body seal leak. Determine if the pressure rating of the cylinder has been exceeded. If so, bring the operating pressure down to the rating of the cylinder and have the tie rods replaced.

Pinched or extruded cylinder body seal will also result in a leak. Replace cylinder body seal and retorque as in paragraph above.

Cylinder body seal leakage due to loss of radial squeeze which shows up in the form of flat spots or due to wear on the O.D. or I.D. – Either of these are symptoms of normal wear due to high cycle rate or length of service. Replace seals as per paragraph above.

4.2.2 – Internal Leakage

4.2.2.1 – Piston seal leak (by-pass) 1 to 3 cubic inches per minute leakage is considered normal for piston ring construction. Virtually no static leak with lipseal type seals on piston should be expected. Piston seal wear is a usual cause of piston seal leakage. Replace seals as required.

4.2.2.2 – With lipseal type piston seals excessive back pressure due to over-adjustment of speed control valves could be a direct cause of rapid seal wear. Contamination in a hydraulic system can result in a scored cylinder bore, resulting in rapid seal wear. In either case, replace piston seals as required.

4.2.2.3 – What appears to be piston seal leak, evidenced by the fact that the cylinder drifts, is not always traceable to the piston. To make sure, it is suggested that one side of the cylinder piston be pressurized and the fluid line at the opposite port be disconnected. Observe leakage. If none is evident, seek the cause of cylinder drift in other component parts in the circuit.

4.2.3 – Cylinder Fails to Move the Load

4.2.3.1 – Pneumatic or hydraulic pressure is too low. Check the pressure at the cylinder to make sure it is to circuit requirements.

4.2.3.2 – Piston Seal Leak – Operate the valve to cycle the cylinder and observe fluid flow at valve exhaust ports at end of cylinder stroke. Replace piston seals if flow is excessive.

4.2.3.3 – Cylinder is undersized for the load – Replace cylinder with one of a larger bore size.

4.3 Erratic or Chatter Operation

4.3.1 – Excessive friction at rod gland or piston bearing due to load misalignment – Correct cylinder-to-load alignment.

4.3.2 – Cylinder sized too close to load requirements – Reduce load or install larger cylinder.

4.3.3 – Erratic operation could be traced to the difference between static and kinetic friction. Install speed control valves to provide a back pressure to control the stroke.

4.4 Cylinder Modifications, Repairs, or Failed Component – Cylinders as shipped from the factory are not to be disassembled and or modified. If cylinders require modifications, these modifications must be done at company locations or by the Company's certified facilities. The Industrial Cylinder Division Engineering Department must be notified in the event of a mechanical fracture or permanent deformation of any cylinder component (excluding seals). This includes a broken piston rod, tie rod, mounting accessory or any other cylinder component. The notification should include all operation and application details. This information will be used to provide an engineered repair that will prevent recurrence of the failure.

It is allowed to disassemble cylinders for the purpose of replacing seals or seal assemblies. However, this work must be done by strictly following all the instructions provided with the seal kits.

Offer of Sale

The items described in this document and other documents and descriptions provided by Parker Hannifin Corporation, its subsidiaries and its authorized distributors ("Seller") are hereby offered for sale at prices to be established by Seller. This offer and its acceptance by any customer ("Buyer") shall be governed by all of the following Terms and Conditions. Buyer's order for any item described in its document, when communicated to Seller verbally, or in writing, shall constitute acceptance of this offer. All goods, services or work described will be referred to as "Products".

1. Terms and Conditions. Seller's willingness to offer Products, or accept an order for Products, to or from Buyer is subject to these Terms and Conditions or any newer version of the terms and conditions found on-line at www.parker.com/saleterms/. Seller objects to any contrary or additional terms or conditions of Buyer's order or any other document issued by Buyer.

2. Price Adjustments; Payments. Prices stated on Seller's quote or other documentation offered by Seller are valid for 30 days, and do not include any sales, use, or other taxes unless specifically stated. Unless otherwise specified by Seller, all prices are F.C.A. Seller's facility (INCOTERMS 2010). Payment is subject to credit approval and is due 30 days from the date of invoice or such other term as required by Seller's Credit Department, after which Buyer shall pay interest on any unpaid invoices at the rate of 1.5% per month or the maximum allowable rate under applicable law.

3. Delivery Dates; Title and Risk; Shipment. All delivery dates are approximate and Seller shall not be responsible for any damages resulting from any delay. Regardless of the manner of shipment, title to any products and risk of loss or damage shall pass to Buyer upon placement of the products with the shipment carrier at Seller's facility. Unless otherwise stated, Seller may exercise its judgment in choosing the carrier and means of delivery. No deferment of shipment at Buyers' request beyond the respective dates indicated will be made except on terms that will indemnify, defend and hold Seller harmless against all loss and additional expense. Buyer shall be responsible for any additional shipping charges incurred by Seller due to Buyer's acts or omissions.

4. Warranty. Seller warrants that the Products sold hereunder shall be free from defects in material or workmanship for a period of eighteen months from the date of delivery to Buyer. The prices charged for Seller's products are based upon the exclusive limited warranty stated above, and upon the following disclaimer: **DISCLAIMER OF WARRANTY: THIS WARRANTY COMPRISES THE SOLE AND ENTIRE WARRANTY PERTAINING TO PRODUCTS PROVIDED HEREUNDER. SELLER DISCLAIMS ALL OTHER WARRANTIES, EXPRESS AND IMPLIED, INCLUDING DESIGN, MERCHANTABILITY AND FITNESS FOR A PARTICULAR PURPOSE.**

5. Claims; Commencement of Actions. Buyer shall promptly inspect all Products upon delivery. No claims for shortages will be allowed unless reported to the Seller within 10 days of delivery. No other claims against Seller will be allowed unless asserted in writing within 30 days after delivery. Buyer shall notify Seller of any alleged breach of warranty within 30 days after the date the defect is or should have been discovered by Buyer. Any action based upon breach of this agreement or upon any other claim arising out of this sale (other than an action by Seller for an amount due on any invoice) must be commenced within 12 months from the date of the breach without regard to the date breach is discovered.

6. LIMITATION OF LIABILITY. UPON NOTIFICATION, SELLER WILL, AT ITS OPTION, REPAIR OR REPLACE A DEFECTIVE PRODUCT, OR REFUND THE PURCHASE PRICE. **IN NO EVENT SHALL SELLER BE LIABLE TO BUYER FOR ANY SPECIAL, INDIRECT, INCIDENTAL OR CONSEQUENTIAL DAMAGES ARISING OUT OF, OR AS THE RESULT OF, THE SALE, DELIVERY, NON-DELIVERY, SERVICING, USE OR LOSS OF USE OF THE PRODUCTS OR ANY PART THEREOF, OR FOR ANY CHARGES OR EXPENSES OF ANY NATURE INCURRED WITHOUT SELLER'S WRITTEN CONSENT, EVEN IF SELLER HAS BEEN NEGLIGENT, WHETHER IN CONTRACT, TORT OR OTHER LEGAL THEORY. IN NO EVENT SHALL SELLER'S LIABILITY UNDER ANY CLAIM MADE BY BUYER EXCEED THE PURCHASE PRICE OF THE PRODUCTS.**

7. User Responsibility. The user, through its own analysis and testing, is solely responsible for making the final selection of the system and Product and assuring that all performance, endurance, maintenance, safety and warning requirements of the application are met. The user must analyze all aspects of the application and follow applicable industry standards and Product information. If Seller provides Product or system options, the user is responsible for determining that such data and specifications are suitable and sufficient for all applications and reasonably foreseeable uses of the Products or systems.

8. Loss to Buyer's Property. Any designs, tools, patterns, materials, drawings, confidential information or equipment furnished by Buyer or any other items which become Buyer's property, will be considered obsolete and may be destroyed by Seller after two consecutive years have elapsed without Buyer ordering the items manufactured using such property. Seller shall not be responsible for any loss or damage to such property while it is in Seller's possession or control.

9. Special Tooling. A tooling charge may be imposed for any special tooling, including without limitation, dies, fixtures, molds and patterns, acquired to manufacture Products. Such special tooling shall be and remain Seller's property notwithstanding payment of any charges by Buyer. In no event will Buyer acquire any interest in apparatus belonging to Seller which is utilized in the manufacture of the Products, even if such apparatus has been specially converted or adapted for such manufacture and notwithstanding any charges paid by Buyer. Unless otherwise agreed, Seller shall have the right to alter, discard or otherwise dispose of any special tooling or other property in its sole discretion at any time.

10. Buyer's Obligation; Rights of Seller. To secure payment of all sums due or otherwise, Seller shall retain a security interest in the goods delivered and this agreement shall be deemed a Security Agreement under the Uniform Commercial Code. Buyer authorizes Seller as its attorney to execute and file on Buyer's behalf all documents Seller deems necessary to perfect its security interest.

11. Improper use and Indemnity. Buyer shall indemnify, defend, and hold Seller harmless from any claim, liability, damages, lawsuits, and costs (including attorney fees), whether for personal injury, property damage, patent, trademark or copyright

infringement or any other claim, brought by or incurred by Buyer, Buyer's employees, or any other person, arising out of: (a) improper selection, improper application or other misuse of Products purchased by Buyer from Seller; (b) any act or omission, negligent or otherwise, of Buyer; (c) Seller's use of patterns, plans, drawings, or specifications furnished by Buyer to manufacture Product; or (d) Buyer's failure to comply with these terms and conditions. Seller shall not indemnify Buyer under any circumstance except as otherwise provided.

12. Cancellations and Changes. Orders shall not be subject to cancellation or change by Buyer for any reason, except with Seller's written consent and upon terms that will indemnify, defend and hold Seller harmless against all direct, incidental and consequential loss or damage. Seller may change product features, specifications, designs and availability with notice to Buyer.

13. Limitation on Assignment. Buyer may not assign its rights or obligations under this agreement without the prior written consent of Seller.

14. Force Majeure. Seller does not assume the risk and shall not be liable for delay or failure to perform any of Seller's obligations by reason of circumstances beyond the reasonable control of Seller (hereinafter "Events of Force Majeure"). Events of Force Majeure shall include without limitation: accidents, strikes or labor disputes, acts of any government or government agency, acts of nature, delays or failures in delivery from carriers or suppliers, shortages of materials, or any other cause beyond Seller's reasonable control.

15. Waiver and Severability. Failure to enforce any provision of this agreement will not waive that provision nor will any such failure prejudice Seller's right to enforce that provision in the future. Invalidation of any provision of this agreement by legislation or other rule of law shall not invalidate any other provision herein. The remaining provisions of this agreement will remain in full force and effect.

16. Termination. Seller may terminate this agreement for any reason and at any time by giving Buyer thirty (30) days written notice of termination. Seller may immediately terminate this agreement, in writing, if Buyer: (a) commits a breach of any provision of this agreement (b) appoints a trustee, receiver or custodian for all or any part of Buyer's property (c) files a petition for relief in bankruptcy on its own behalf, or by a third party (d) makes an assignment for the benefit of creditors, or (e) dissolves or liquidates all or a majority of its assets.

17. Governing Law. This agreement and the sale and delivery of all Products hereunder shall be deemed to have taken place in and shall be governed and construed in accordance with the laws of the State of Ohio, as applicable to contracts executed and wholly performed therein and without regard to conflicts of laws principles. Buyer irrevocably agrees and consents to the exclusive jurisdiction and venue of the courts of Cuyahoga County, Ohio with respect to any dispute, controversy or claim arising out of or relating to this agreement.

18. Indemnity for Infringement of Intellectual Property Rights. Seller shall have no liability for infringement of any patents, trademarks, copyrights, trade dress, trade secrets or similar rights except as provided in this Section. Seller will defend and indemnify Buyer against allegations of infringement of U.S. patents, U.S. trademarks, copyrights, trade dress and trade secrets ("Intellectual Property Rights"). Seller will defend at its expense and will pay the cost of any settlement or damages awarded in an action brought against Buyer based on an allegation that a Product sold pursuant to this Agreement infringes the Intellectual Property Rights of a third party. Seller's obligation to defend and indemnify Buyer is contingent on Buyer notifying Seller within ten (10) days after Buyer becomes aware of such allegations of infringement, and Seller having sole control over the defense of any allegations or actions including all negotiations for settlement or compromise. If a Product is subject to a claim that it infringes the Intellectual Property Rights of a third party, Seller may, at its sole expense and option, procure for Buyer the right to continue using the Product, replace or modify the Product so as to make it noninfringing, or offer to accept return of the Product and return the purchase price less a reasonable allowance for depreciation. Notwithstanding the foregoing, Seller shall have no liability for claims of infringement based on information provided by Buyer, or directed to Products delivered hereunder for which the designs are specified in whole or part by Buyer, or infringements resulting from the modification, combination or use in a system of any Product sold hereunder. The foregoing provisions of this Section shall constitute Seller's sole and exclusive liability and Buyer's sole and exclusive remedy for infringement of Intellectual Property Rights.

19. Entire Agreement. This agreement contains the entire agreement between the Buyer and Seller and constitutes the final, complete and exclusive expression of the terms of sale. All prior or contemporaneous written or oral agreements or negotiations with respect to the subject matter are herein merged.

20. Compliance with Law, U. K. Bribery Act and U.S. Foreign Corrupt Practices Act. Buyer agrees to comply with all applicable laws and regulations, including both those of the United Kingdom and the United States of America, and of the country or countries of the Territory in which Buyer may operate, including without limitation the U. K. Bribery Act, the U.S. Foreign Corrupt Practices Act ("FCPA") and the U.S. Anti-Kickback Act (the "Anti-Kickback Act"), and agrees to indemnify and hold harmless Seller from the consequences of any violation of such provisions by Buyer, its employees or agents. Buyer acknowledges that they are familiar with the provisions of the U. K. Bribery Act, the FCPA and the Anti-Kickback Act, and certifies that Buyer will adhere to the requirements thereof. In particular, Buyer represents and agrees that Buyer shall not make any payment or give anything of value, directly or indirectly to any governmental official, any foreign political party or official thereof, any candidate for foreign political office, or any commercial entity or person, for the purpose of influencing such person to purchase products or otherwise benefit the business of Seller.

Parker's Motion & Control Technologies

At Parker, we're guided by a relentless drive to help our customers become more productive and achieve higher levels of profitability by engineering the best systems for their requirements. It means looking at customer applications from many angles to find new ways to create value. Whatever the motion and control technology need, Parker has the experience, breadth of product and global reach to consistently deliver. No company knows more about motion and control technology than Parker. For further info call 1 800 C-Parker (1 800 272 7537).



AEROSPACE

Key Markets

- Aircraft engines
- Business & general aviation
- Commercial transports
- Land-based weapons systems
- Military aircraft
- Missiles & launch vehicles
- Regional transports
- Unmanned aerial vehicles

Key Products

- Flight control systems & components
- Fluid conveyance systems
- Fluid metering delivery & atomization devices
- Fuel systems & components
- Hydraulic systems & components
- Inert nitrogen generating systems
- Pneumatic systems & components
- Wheels & brakes



CLIMATE CONTROL

Key Markets

- Agriculture
- Air conditioning
- Food, beverage & dairy
- Life sciences & medical
- Precision cooling
- Processing
- Transportation

Key Products

- CO₂ controls
- Electronic controllers
- Filter driers
- Hand shut-off valves
- Hose & fittings
- Pressure regulating valves
- Refrigerant distributors
- Safety relief valves
- Solenoid valves
- Thermostatic expansion valves



ELECTROMECHANICAL

Key Markets

- Aerospace
- Factory automation
- Food & beverage
- Life science & medical
- Machine tools
- Packaging machinery
- Paper machinery
- Plastics machinery & converting
- Primary metals
- Semiconductor & electronics
- Textile
- Wire & cable

Key Products

- AC/DC drives & systems
- Electric actuators
- Controllers
- Gantry robots
- Gearheads
- Human machine interfaces
- Industrial PCs
- Inverters
- Linear motors, slides and stages
- Precision stages
- Stepper motors
- Servo motors, drives & controls
- Structural extrusions



FILTRATION

Key Markets

- Food & beverage
- Industrial machinery
- Life sciences
- Marine
- Mobile equipment
- Oil & gas
- Power generation
- Process
- Transportation

Key Products

- Analytical gas generators
- Compressed air & gas filters
- Condition monitoring
- Engine air, fuel & oil filtration & systems
- Hydraulic, lubrication & coolant filters
- Process, chemical, water & microfiltration filters
- Nitrogen, hydrogen & zero air generators



FLUID & GAS HANDLING

Key Markets

- Aerospace
- Agriculture
- Bulk chemical handling
- Construction machinery
- Food & beverage
- Fuel & gas delivery
- Industrial machinery
- Mobile
- Oil & gas
- Transportation
- Welding

Key Products

- Brass fittings & valves
- Diagnostic equipment
- Fluid conveyance systems
- Industrial hose
- PTFE & PFA hose, tubing & plastic fittings
- Rubber & thermoplastic hose & couplings
- Tube fittings & adapters
- Quick disconnects



HYDRAULICS

Key Markets

- Aerospace
- Aerial lift
- Agriculture
- Construction machinery
- Forestry
- Industrial machinery
- Mining
- Oil & gas
- Power generation & energy
- Truck hydraulics

Key Products

- Diagnostic equipment
- Hydraulic cylinders & accumulators
- Hydraulic motors & pumps
- Hydraulic systems
- Hydraulic valves & controls
- Power take-offs
- Rubber & thermoplastic hose & couplings
- Tube fittings & adapters
- Quick disconnects



PNEUMATICS

Key Markets

- Aerospace
- Conveyor & material handling
- Factory automation
- Food & beverage
- Life science & medical
- Machine tools
- Packaging machinery
- Transportation & automotive

Key Products

- Air preparation
- Compact cylinders
- Field bus valve systems
- Grippers
- Guided cylinders
- Manifolds
- Miniature fluidics
- Pneumatic accessories
- Pneumatic actuators & grippers
- Pneumatic valves and controls
- Rodless cylinders
- Rotary actuators
- Tie rod cylinders
- Vacuum generators, cups & sensors



PROCESS CONTROL

Key Markets

- Chemical & refining
- Food, beverage & dairy
- Medical & dental
- Microelectronics
- Oil & gas
- Power generation

Key Products

- Analytical sample conditioning products & systems
- Fluoropolymer chemical delivery fittings, valves & pumps
- High purity gas delivery fittings, valves & regulators
- Instrumentation fittings, valves & regulators
- Medium pressure fittings & valves
- Process control manifolds



SEALING & SHIELDING

Key Markets

- Aerospace
- Chemical processing
- Consumer
- Energy, oil & gas
- Fluid power
- General industrial
- Information technology
- Life sciences
- Military
- Semiconductor
- Telecommunications
- Transportation

Key Products

- Dynamic seals
- Elastomeric o-rings
- EMI shielding
- Extruded & precision-cut, fabricated elastomeric seals
- Homogeneous & inserted elastomeric shapes
- High temperature metal seals
- Metal & plastic retained composite seals
- Thermal management



ENGINEERING YOUR SUCCESS.

Parker Hannifin Corporation
Industrial Cylinder Division
500 South Wolf Road
Des Plaines, IL 60016
phone (847) 298-2400
fax (800) 892-1008
www.parker.com/cylinder

