



598/599P

External Stack

HA500841 Issue 3
Application Manual

aerospace
climate control
electromechanical
filtration
fluid & gas handling
hydraulics
pneumatics
process control
sealing & shielding



ENGINEERING YOUR SUCCESS.



598/599P External Stack Controller DC Digital Drive

Application Manual
HA500841 Issue 3

© Copyright Parker Hannifin Limited 2012

All rights strictly reserved. No part of this document may be stored in a retrieval system, or transmitted in any form or by any means to persons not employed by a Parker Hannifin Manufacturing Limited company without written permission from Parker Hannifin Manufacturing Limited. Although every effort has been taken to ensure the accuracy of this document it may be necessary, without notice, to make amendments or correct omissions. Parker Hannifin Manufacturing Limited cannot accept responsibility for damage, injury, or expenses resulting therefrom.

WARRANTY

Refer to Parker Hannifin Manufacturing Limited Terms and Conditions of Sale. These documents are available on request at www.parker.com

Parker Hannifin Manufacturing Limited reserves the right to change the content and product specification without notice.

Safety Information



FAILURE OR IMPROPER SELECTION OR IMPROPER USE OF THE PRODUCTS DESCRIBED HEREIN OR RELATED ITEMS CAN CAUSE DEATH, PERSONAL INJURY AND PROPERTY DAMAGE.

- This document and other information from Parker-Hannifin Corporation, its subsidiaries and authorized distributors provide product or system options for further investigation by users having technical expertise.
- The user, through its own analysis and testing, is solely responsible for making the final selection of the system and components and assuring that all performance, endurance, maintenance, safety and warning requirements of the application are met. The user must analyze all aspects of the application, follow applicable industry standards, and follow the information concerning the product in the current product catalogue and in any other materials provided from Parker or its subsidiaries or authorized distributors.
- To the extent that Parker or its subsidiaries or authorized distributors provide component or system options based upon data or specifications provided by the user, the user is responsible for determining that such data and specifications are suitable and sufficient for all applications and reasonably foreseeable uses of the components or systems.

Requirements

IMPORTANT Please read this information **BEFORE** installing the equipment.

Intended Users

This manual is to be made available to all persons who are required to install, configure or service equipment described herein, or any other associated operation.

The information given is intended to highlight safety issues, and to enable the user to obtain maximum benefit from the equipment.

Complete the following table for future reference detailing how the unit is to be installed and used.

INSTALLATION DETAILS			
Model Number <i>(see product label)</i>		Where installed <i>(for your own information)</i>	
Unit used as a: <i>(refer to "Certification")</i>	<input type="radio"/> Component <input type="radio"/> Relevant Apparatus	Unit fitted:	<input checked="" type="checkbox"/> Enclosure

Application Area

The equipment described is intended for an industrial (non-consumer) user, for the control of an external thyristor controlled bridge.

Personnel

Installation, operation and maintenance of the equipment should be carried out by qualified personnel. A qualified person is someone who is technically competent and familiar with all safety information and established safety practices; with the installation process, operation and maintenance of this equipment; and with all the hazards involved.

Product Warnings

<p>Caution Risk of electric shock</p>	<p>Caution Refer to documentation</p>	<p>Earth/Ground Protective Conductor Terminal</p>
--	--	--

Safety Information



Hazards

DANGER! - Ignoring the following may result in injury

1. This equipment can endanger life by exposure to rotating machinery and high voltages.
2. The equipment must be permanently earthed due to the high earth leakage current, and the drive motor must be connected to an appropriate safety earth.
3. Ensure all incoming supplies are isolated before working on the equipment. Be aware that there may be more than one supply connection to the drive.
4. There may still be dangerous voltages present at power terminals (motor output, supply input phases, DC bus and the brake, where fitted) when the motor is at standstill or is stopped.
5. For measurements use only a meter to IEC 61010 (CAT III or higher). Always begin using the highest range. CAT I and CAT II meters must not be used on this product.
6. Allow at least 10 minutes for the stack controllers capacitors to discharge to safe voltage levels (<50V). Use the specified meter capable of measuring up to 1000V dc & ac rms to confirm that less than 50V is present between all power terminals and between power terminals and earth.
7. Unless otherwise stated, this product must NOT be dismantled. In the event of a fault the drive must be returned. Refer to "Routine Maintenance and Repair".

WARNING! - Ignoring the following may result in injury or damage to equipment

SAFETY

Where there is conflict between EMC and Safety requirements, personnel safety shall always take precedence.

- Never perform high voltage resistance checks on the wiring without first disconnecting the drive from the circuit being tested.
- Whilst ensuring ventilation is sufficient, provide guarding and /or additional safety systems to prevent injury or damage to equipment.
- When replacing a drive in an application and before returning to use, it is essential that all user defined parameters for the product's operation are correctly installed.
- All control and signal terminals are SELV, i.e. protected by double insulation. Ensure all external wiring is rated for the highest system voltage.
- Thermal sensors contained within the motor must have at least basic insulation.
- All exposed metalwork in the Drive is protected by basic insulation and bonded to a safety earth.
- RCDs are not recommended for use with this product but, where their use is mandatory, only Type B RCDs should be used.

CAUTION!

APPLICATION RISK

- The specifications, processes and circuitry described herein are for guidance only and may need to be adapted to the user's specific application. We can not guarantee the suitability of the equipment described in this Manual for individual applications.

RISK ASSESSMENT

Under fault conditions, power loss or unintended operating conditions, the stack controller may not operate as intended. In particular:

- Stored energy might not discharge to safe levels as quickly as suggested, and can still be present even though the drive appears to be switched off
- The motor's direction of rotation might not be controlled
- The motor speed might not be controlled
- The motor might be energised

The stack controller is a component within a drive or drive system that may influence its operation or effects under a fault condition. Consideration must be given to:

- Stored energy
- Supply disconnects
- Sequencing logic
- Unintended operation

598P/599P APPLICATION MANUAL

Contents

Overview	1
Outline Drawing.....	1
Electrical Installation	2
3-Phase Contactor	2
Auxiliary Supply	2
Semiconductor Fuses.....	2
Current Transformers	2
Heatsink Thermostats	2
PROTECTION OF STACK CONTROL AND FEEDBACK WIRING	3
THYRISTOR TRIGGER OUTPUT OPTIONS.....	3
1. Trigger Board Output Option	3
2. Amplifier Output Option.....	5
Power Connections	6
Minimum Connection 4Q Stack Trigger Board Option	6
Minimum Connection 2Q Stack Trigger Board Option	7
Pulse Amplifier Connections 4Q Stack	8
Power Amplifier Connections 2Q Stack.....	9
598/599P Set-up Procedure.....	10
Calibration Switch.....	10
Armature Current Calibration.....	10
Field Current Calibration.....	10
Armature Voltage Calibration.....	10
Technical Specification.....	11
Environmental Data	11
Electrical Ratings	11
Field Fusing	11
Thyristor Wiring.....	12
Standard Trigger Board Terminal Assignment.....	12
4 Quad	12
2 Quad	12
Optoisolator Trigger Board Terminal Assignment.....	13
4 Quad	13
2 Quad	13
Optoisolator Firing Board Terminal Layout and Dimensions.....	14
Version 1	14
Version 2	15
Product Code	16
Legacy Product Code	17
CERTIFICATION	18
Europe.....	18
CE Marking for the Low Voltage Directive (LVD) 2006/95/EC	18
CE Marking for the EMC Directive 2004/108/EC.....	19
EMC General Installation Considerations.....	19

Overview

The 598/9P External Stack Controller Assembly provides the Hardware necessary to interface the 590Plus Control Door to an existing 3 Phase Stack assembly. The Design assumes that a Fully Controlled 3 Phase Six Pulse Converter exists which is complete with Thyristor Suppression, Current Feedback, Temperature Monitoring and Suitable Fusing.

The External Stack Controller Module provides: -

- Thyristor Firing Signals;
- Thyristor Firing Pulse Transformers;
- ACCT Feedback Rectification and Scaling;
- Armature Voltage Feedback Interface;
- Coding and Phase Rotation Interface;
- Mains Present Monitoring
- Heatsink Over-temperature Input;
- Field Power Modules and Input / Output Terminations;
- Field Current Monitoring and Scaling;
- All Standard 590Plus I/O Terminations.

Outline Drawing

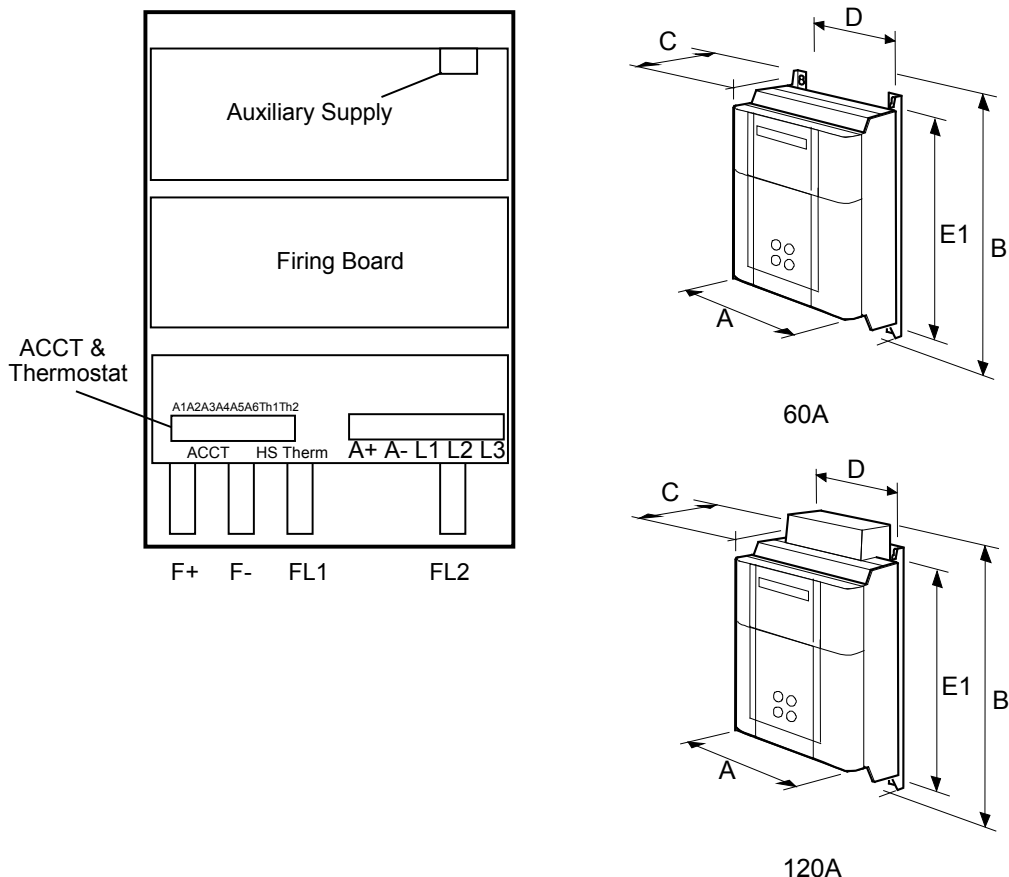

Current Rating (A)	Weight in Kg (lbs.)	Overall Dimensions			Fixing Centres	
		A	B	C	D	E1
60	10-14 (22-30)	250 (9.8)	415 (16.3)	180 (7.1)	200 (7.9)	400 (15.7)
120	15 (33.2)	250 (9.8)	445 (17.5)	180 (7.1)	200 (7.9)	400 (15.7)

Dimensions are in millimetres (inches)

Electrical Installation

3-PHASE CONTACTOR

An AC Line Contactor should be connected in series with the 3 Phase Power AC Supply to the Power Stack. The Contactor does not switch current and should be driven via the Pilot Relay provided on the Power Board. The Pilot Relay has a limited drive capability of 3 Amps and it is likely that the Inrush Current of the Contactor used in this application will exceed this level and thus an intermediate Slave Relay should be fitted which is controlled directly by the Drive with Contacts of this Slave Relay used to Close the Main Contactor. If the use of a DC Contactor is preferred the coil should be controlled by a Slave Relay as previously described however it is important to connect an Auxiliary Contact from this DC Contactor into the Enable Input of the Drive Module on Control Board Terminal C5 to guarantee the correct sequencing of the Control Circuits.

AUXILIARY SUPPLY

The Controller needs an Auxiliary Supply to provide the Power for the Control Electronics Power Supplies and the Slave Relay Coil. This should be a Single Phase AC Supply in the range 110Vac to 240 Vac 50/60 Hz. The Electronic Power Supply Circuitry will function over this range without difficulty however the Pilot Relay uses this supply to drive the Slave Contactor; hence the Auxiliary Supply Voltage should be tailored to suit the desired coil voltage of the Slave Relay.

When the 598/9P External Stack Controller is required to power a Motor Field with a current greater than 60 amps an Auxiliary Fan will be fitted to the module, this Fan will be either 100/120 Vac or 220/240 Vac depending upon the Customer Order requirements.

SEMICONDUCTOR FUSES

Semiconductor Fuses should always be provided to protect the Power Thyristors under fault conditions. Where Line Fuses are used the Coding and Mains Present should be connected to the Stack side of the Fuse to enable the Mains Present to detect Fuse Failure and inhibit the Control Circuits. Where Limb Fuses are used Micro-switches should be added to the Indicator Fuses to detect fuse failure and the resultant combined signal used to disable the Controller via the Enable Input.

Semiconductor fuses must also be provided for the Field AC Supply to protect the Field Power Devices. These fuses should be selected to limit the Fault I^2t through the Device to within the Device Rating.

CURRENT TRANSFORMERS

The Drive Module relies upon Current Transformers to provide a measurement of the outgoing Armature Current. The unit is designed to operate with Current Transformers with a ratio of 2000:1 and the Calibration calculations and scaling will operate normally. Any other ratio of the Current Transformer will result in a Calibration error in the Software, i.e. a 1000:1 CT will actually result in half the expected output current.

The Current Transformer, if not purchased from Parker SSD Drives, should have a core with a low magnetising current to reduce the measurement error, and maximum output voltage of approximately 6 volts. Under normal operation the output from the three Current Transformers is fed via a 3 phase rectifier to a fixed burden, thus the output voltage under normal conditions is 1.1Vdc plus two diode volt drops. The Current Transformer should cater for a worst case overload of 3 times Full Load Current or a maximum output of 3.3Vdc plus two diode drops.

HEATSINK THERMOSTATS

Since most High Current Stack assemblies are force cooled, a Digital Input is provided on the External Stack Module to shutdown the controller in the event of Cooling Failure or Heatsink over-temperature. The Input Circuitry is operating at Control Signal voltage levels hence SELV and has no Safety Isolation. If Thermostats are being used which are fitted to a "Live" Heatsink then the contacts of the Thermostats should be "anded" together via relay logic and the Volt Free Contact of the Output Relay used to drive the Heatsink Over-temperature Input. It is important to ensure that each individual Thermostat is capable of providing Basic Isolation at the Stack Supply Voltage since the contacts will be connected to drive via the Output Relay which itself provides the second level of Basic Isolation giving Double Isolation of the SELV circuitry.

PROTECTION OF STACK CONTROL AND FEEDBACK WIRING

Suitable fuse protection should be installed against faults in the armature voltage feedback wiring, against faults in the line voltage sensing and against faults in the thyristor trigger firing circuits/wiring. These fuses should be located at the external stack end of the wiring.

Fuses applied to the thyristor firing wires should be two-up (i.e. in each of the Gate and Cathode wires), and should make use of twisted pair wiring either side of the fusing. The fuse current rating used for the thyristor firing wires should be appropriate for the size of wires used, and yet rated at not less than 2A rms. The fuse voltage rating should be appropriate for the external stack system voltage.

THYRISTOR TRIGGER OUTPUT OPTIONS

There are two options available to provide the triggering of the external stack thyristors:

1. Trigger Board Output Option

Trigger Board output option (product codes with 'TP' starting code block 3)

This option makes use of direct driven pulse transformers, locally mounted in the external stack controller. It provides isolated drive signals that can be wired directly to the external stack thyristor gate terminals (via appropriate fusing, see earlier).

There are two voltage ratings of this output option available:

500Vac rms (product codes with '23' or '53' starting code block 2)

690Vac rms (product codes with '73' starting code block 2)

The two voltage ratings of this output option have differing drive capabilities, and they are described by the following typical drive parameters (onto a 2.5V load) and steady-state Voltage-Current characteristics:

	500Vac rms Option	690Vac rms Option
Initial Current Step	0.55A	0.35A
Initial Current Rise Time	0.3 μ s	0.3 μ s
Delay to Steady-State Current	3 μ s	6 μ s
Trigger Pulse Width	175 μ s	425 μ s

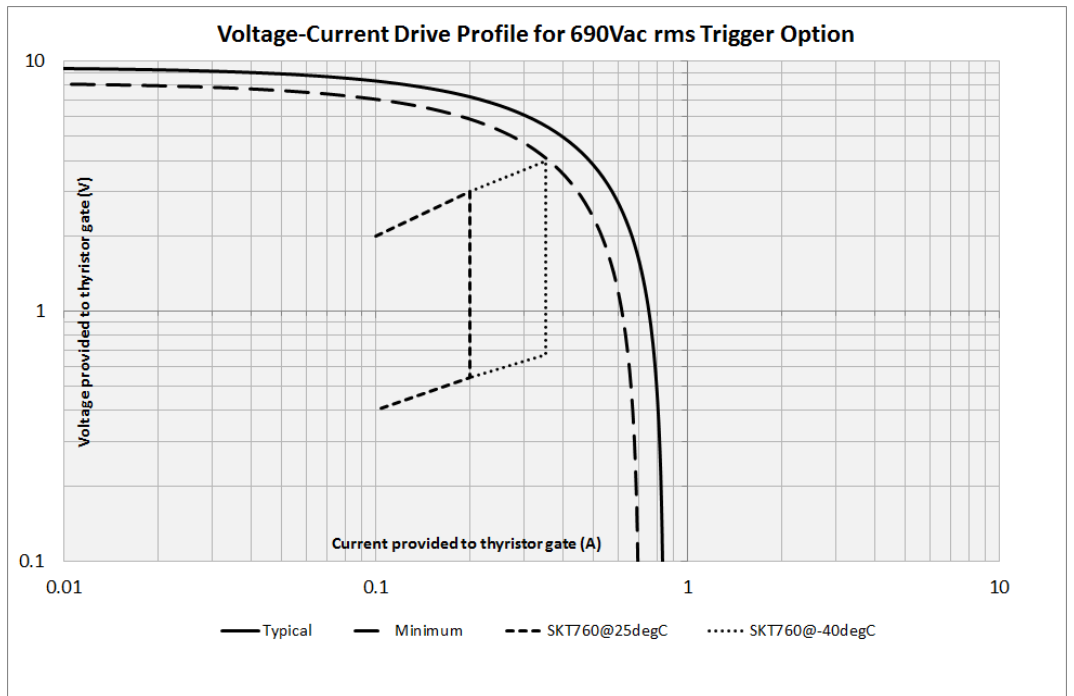
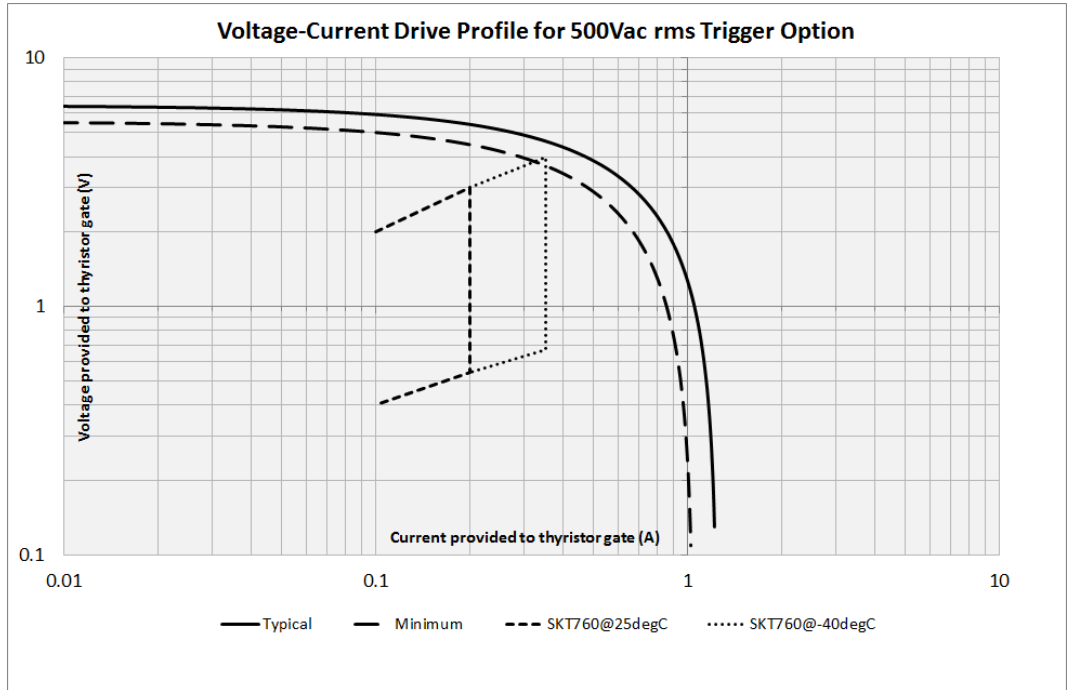

Each semiconductor manufacturer provides a thyristor Gate Trigger Characteristic to allow the gate drive to be designed.

The Voltage-Current characteristic of the gate trigger output should be plotted onto the thyristor Gate Trigger Characteristic, and a check made to ensure that the curve passes through the Area of Certain Triggering, with sufficient margin. It should be noted that the drive required is dependent on the maximum rate of rise of current that will occur in the thyristor in the application, and on the minimum temperature of operation.

Always consult the thyristor manufacturer if there is any doubt whether the gate trigger output is compatible.

The gate trigger output wiring is included for the 500Vac rms rated option, in the form of 3m long, sleeved, twisted-pair cable assemblies, which plug into sockets on the Trigger Board assembly. The sleeving is provided for both electrical and mechanical protection, and is rated at 600V.

The gate trigger output wiring is not included for the 690Vac rms rated option, the signals being made available through 2-way terminal blocks on the Trigger Board assembly.

The terminal blocks should be tightened to a torque of **0.5Nm**.

With this option, the wire used for the trigger connections must meet the following requirements:

Type	Twisted-Pair
Size (each wire)	16AWG – 20AWG (0.5mm ² – 1.5mm ²)
Twist Rate	45 – 80 twists per metre
Minimum Rated Voltage	Refer to external stack system voltage
Minimum Rated Temp.	105°C
Colouring	Twin coloured, for gate and cathode identification
Secondary Outer Slewing	Required for the length of passage from trigger board terminal blocks to the wire exiting the 598P/599P External Stack Controller. Rated for the external stack system voltage, and 105°C operation.
Maximum Run Length	3m
Wire Grouping	Run trigger wires as a bundled group, where possible.

[Suitable example wires (before twisting) would be type 1856 (for 600Vac rms operation) or type 22007 (for 690Vac rms operation), and example sleeving would be PVC-105-6, all from Alpha Wire]

The applied secondary outer sleeving should extend to within 10mm of the terminal block, to assure correct insulation of the trigger wires as they exit the trigger board assembly (see below).

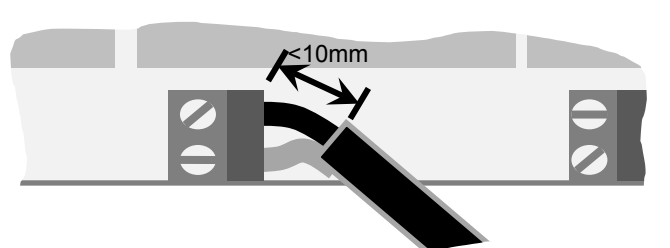

2. Amplifier Output Option

Amplifier output option (product codes with 'AP' starting code block 3).

This option makes use of separate Firing Amplifier Board assemblies (supplied), which can be fitted close to the external stack thyristors, thus simplifying the wiring safety considerations. These amplifiers require a separate 24Vdc power supply, but provide a higher output current capability for larger thyristor driving.

The wiring from the Amplifier Option Terminal Board to the separate Firing Amplifier Boards is low-voltage control wiring, and should be routed/treated as such in the system design.

WARNING

System Safety and Interlocks

The application should be designed such that all failure modes have been considered and the overall system design fails safe.

This includes, but is not limited to, the loss of armature voltage or speed feedback and armature current feedback. The enable input and/or coast stop could be used as part of this strategy for the necessary safety interlocks.

Power Connections Minimum Connection 4Q Stack Trigger Board Option

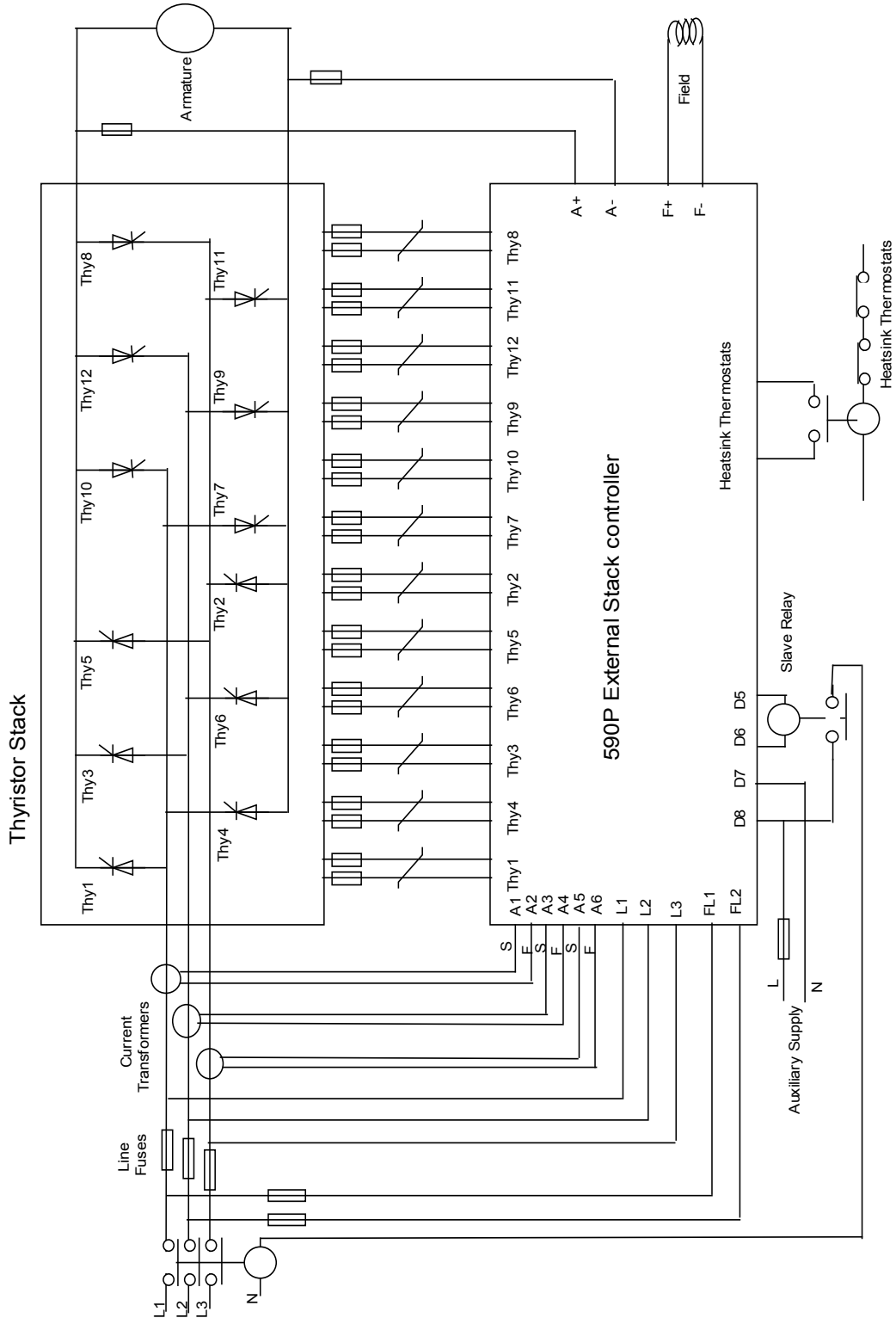

Minimum Connection 2Q Stack Trigger Board Option

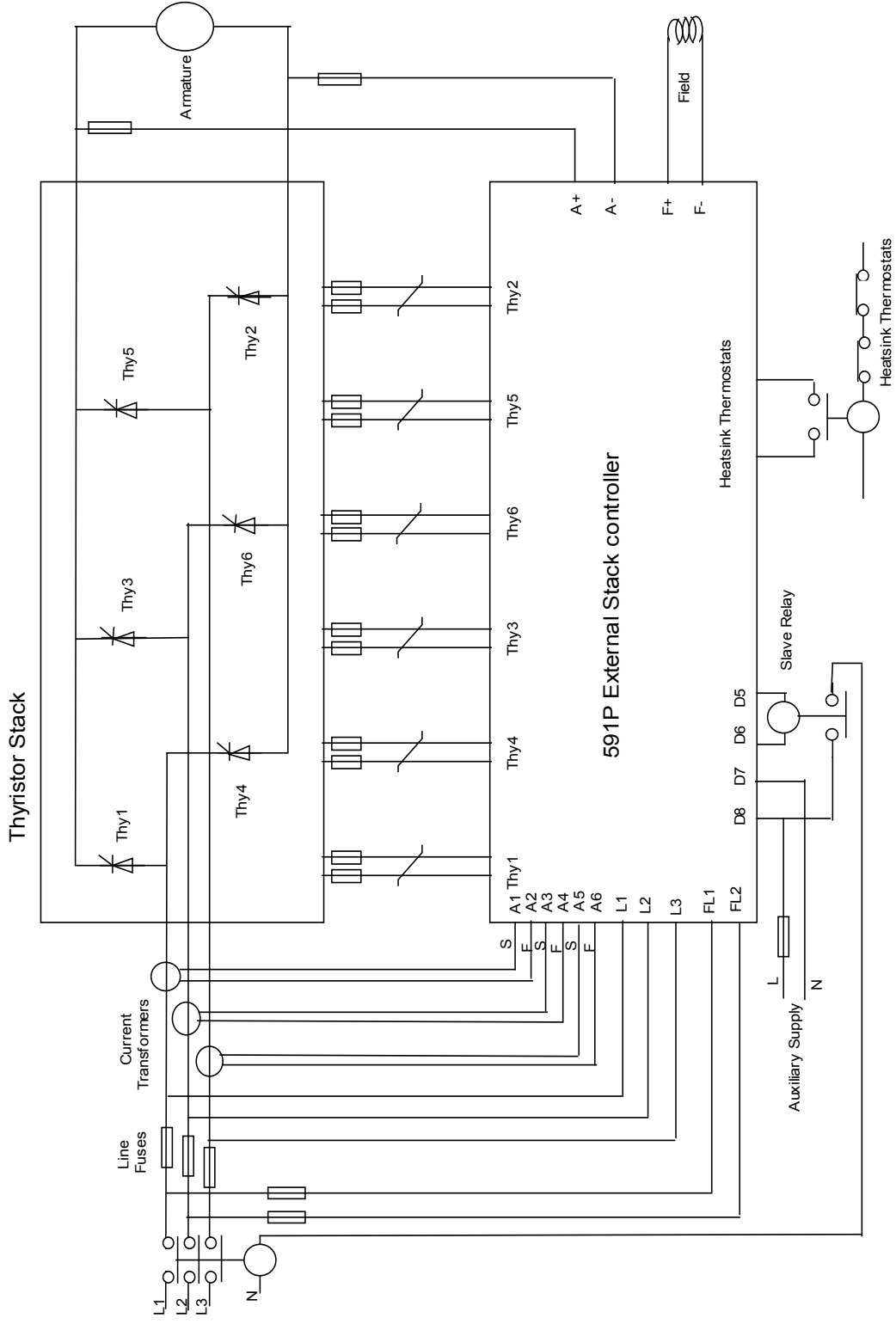

Pulse Amplifier Connections 4Q Stack

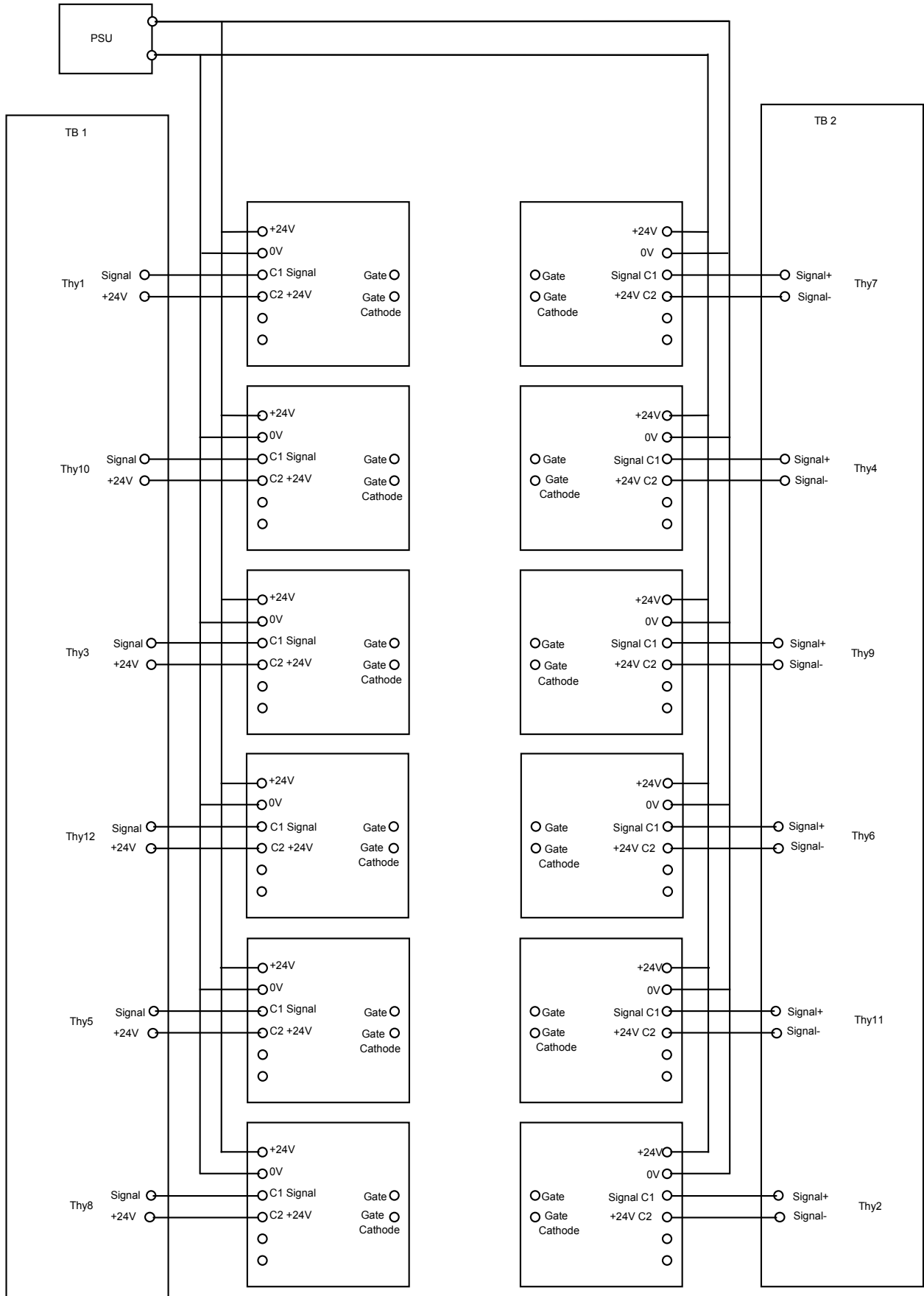

4Q Power Amplifier Connections.

Power Amplifier Connections 2Q Stack

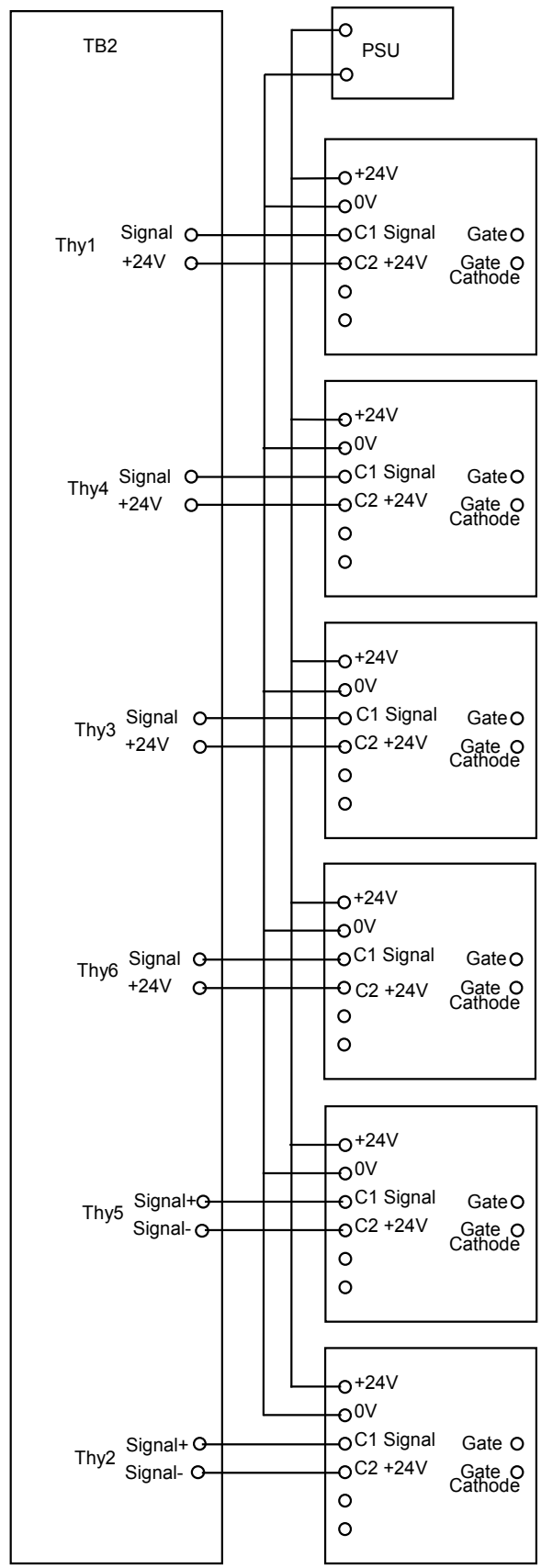

2Q Power Amplifier Connections.

598/599P Set-up Procedure

At the moment the software identifies the 590P External Stack Module as a 590PH Module and therefore the External Stack must be set for a similar current range to an equivalent 590PH.

CALIBRATION SWITCH

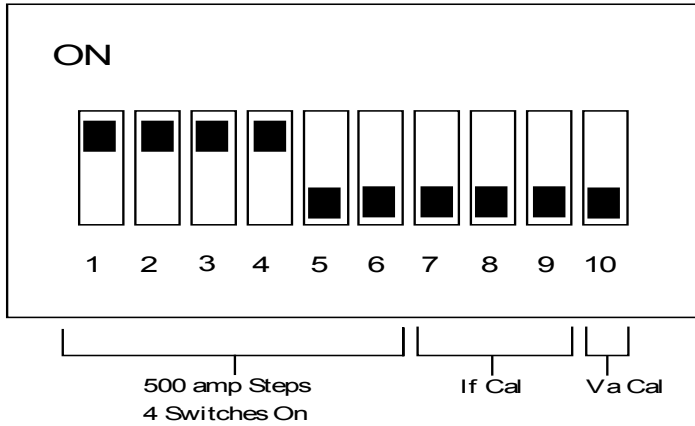

ARMATURE CURRENT CALIBRATION

4 Switches must be “On” under ALL circumstances. The Drive Software will then scale the Current Feedback Signal to give the desired Output Current provided the correct ACCTs of a ratio of 2000 to 1 have been fitted.

FIELD CURRENT CALIBRATION

SW7	SW8	SW9	Field Calibration
0	0	0	20
0	0	1	40
0	1	0	60
0	1	1	80
1	0	0	100
1	0	1	120

ARMATURE VOLTAGE CALIBRATION

SW10	Attenuation	Calibration
0	Va/100	Normal
1	Va/200	Va/2

Example

Set the Product Code of the Module to a 590H of the same Current Range as the Stack and with the associated maximum field current calibration. i.e. for a 2Q Stack with a 2000 Amps Armature and a 35 Amps Field set the Product Code to DC 2Q 2200A 40 D

Set the Field Calibration switches to the appropriate range i.e. with SW7 OFF, SW8 OFF & SW9 ON.

Adjust the Armature Current and other parameters as normal provided the external CT is 2000:1.

For a different CT Ratio “R” set the Armature Current using an appropriate multiplier where the multiplier $M = 2000/R$ and the Armature Current Setting is $M * \text{Normal}$. i.e. if the CT Ratio is 1000:1 you will need to set $2 * \text{the required current}$. Note this may mean that you may have to select a Higher Current Range on the Initial Product.

Technical Specification

ENVIRONMENTAL DATA

Operating Temperature	0 to +45°C
Storage Temperature	-25 to +55°C
Shipping Temperature	-25 to +70°C
Enclosure Rating	IP20
Altitude Rating	Maximum Altitude 500 metres. De-rate the Output at 1% per 200 metres.
Humidity	Maximum 85% relative Humidity at 45°C non-condensing.
Atmosphere	Non flammable, non-corrosive and dust free.
Climatic	Class 3k3 as defined by EN60721-3-3 (1995).
Safety Europe	Designed to : - EN50178 when enclosure mounted. Overvoltage Category III Pollution Degree 2

ELECTRICAL RATINGS

Coding Supply Voltage	110 – 240 Vac \pm 10% 3ph – Low Voltage Build 220 – 500 Vac \pm 10% 3ph – Medium Voltage Build 380 – 690 Vac \pm 10% 3ph – High Voltage Build
Field Supply Voltage	110 – 240 Vac \pm 10% 1ph – Low Voltage Build *220 – 500 Vac \pm 10% 1ph – Medium Voltage Build *380 – 690 Vac \pm 10% 1ph – High Voltage Build <i>* The field supply of the 220-500V and 380-690Vac rated products must be derived from line-to-line of a 3 phase supply, NOT from line-to-neutral.</i>
Supply Frequency	50/60 Hz \pm 10%
Armature Thyristor Firing Isolation	Suitable for external stack supply system rated: Overvoltage Category III Max. 500Vac rms for Medium Voltage Build Max. 690Vac rms for High Voltage Build
Output Current	60 Amps dc naturally cooled - 120 amps dc Force Cooled. De-rate linearly at 1% per °C above rated temperature.
Supply Current Field Coding	(1 times Field Current dc value) Amps 1ph ac. Nominal 3ph ac.
Field Output Voltage	(0.9 times 1ph Supply Voltage) V dc
Total Losses	(3 times Idc out) Watts.
Auxiliary Supply	110 – 240 Vac \pm 10% 1ph – Naturally Cooled. 110 – 120 Vac \pm 10% 1ph – Force Cooled 115 Vac Fan configuration. 220 – 240 Vac \pm 10% 1ph – Force Cooled 230 Vac Fan configuration.
Auxiliary Supply Current	SMPS Quiescent Current – 500mA 115 Vac or 250mA 230 Vac i.e. 50 VA. Fan Current - 270mA @ 115 Vac or 135mA @ 230 Vac.
Auxiliary Supply Fuse	3 Amps.

FIELD FUSING

DC Output	Supply Voltage	Semiconductor I ² t	Fuse Rating	Fuse I ² t	Parker SSD Part No.
60 Amps	500 Vac	19100 A ² s	80 amps	2550 A ² s	CH570084
120 Amps	500 Vac	19100 A ² s	125 amps	8500 A ² s	CH571253
60 Amps	690 Vac	8830 A ² s	80 amps	2550 A ² s	CH570084
120 Amps	690 Vac	8830 A ² s	125 amps	8500 A ² s	CH571253

Thyristor Wiring

STANDARD TRIGGER BOARD TERMINAL ASSIGNMENT

4 Quad

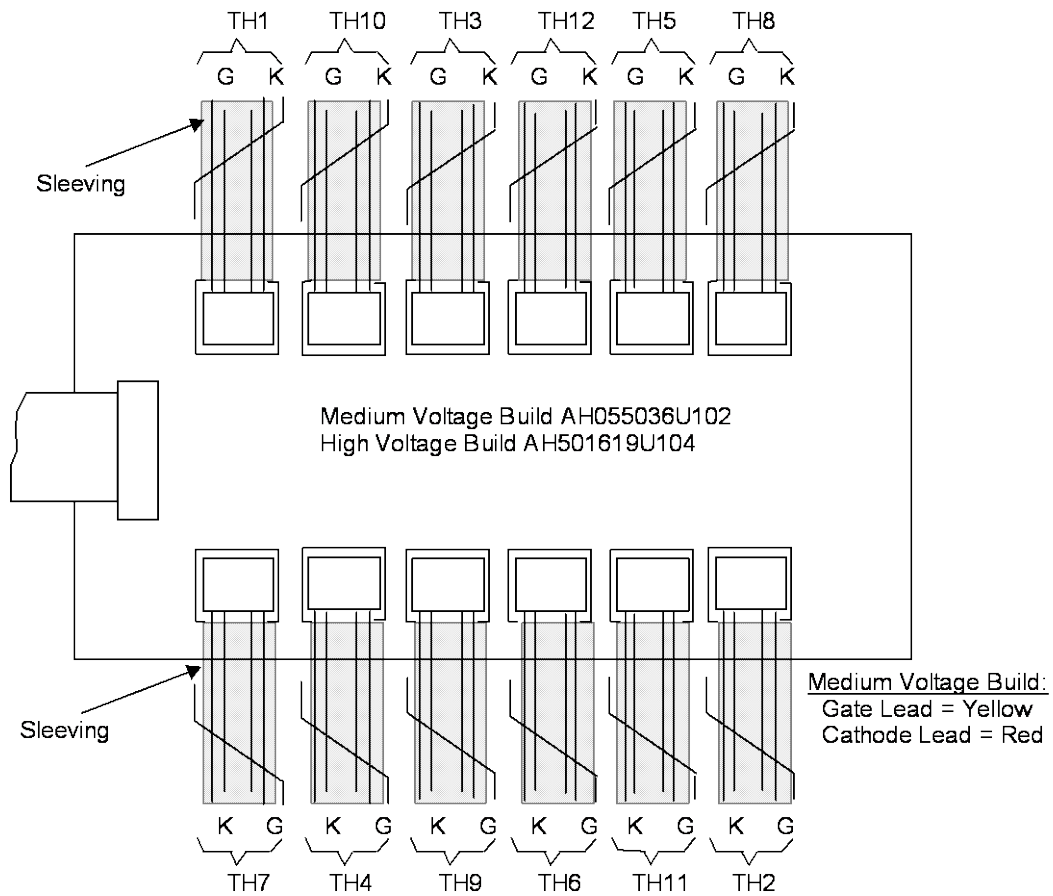

2 Quad

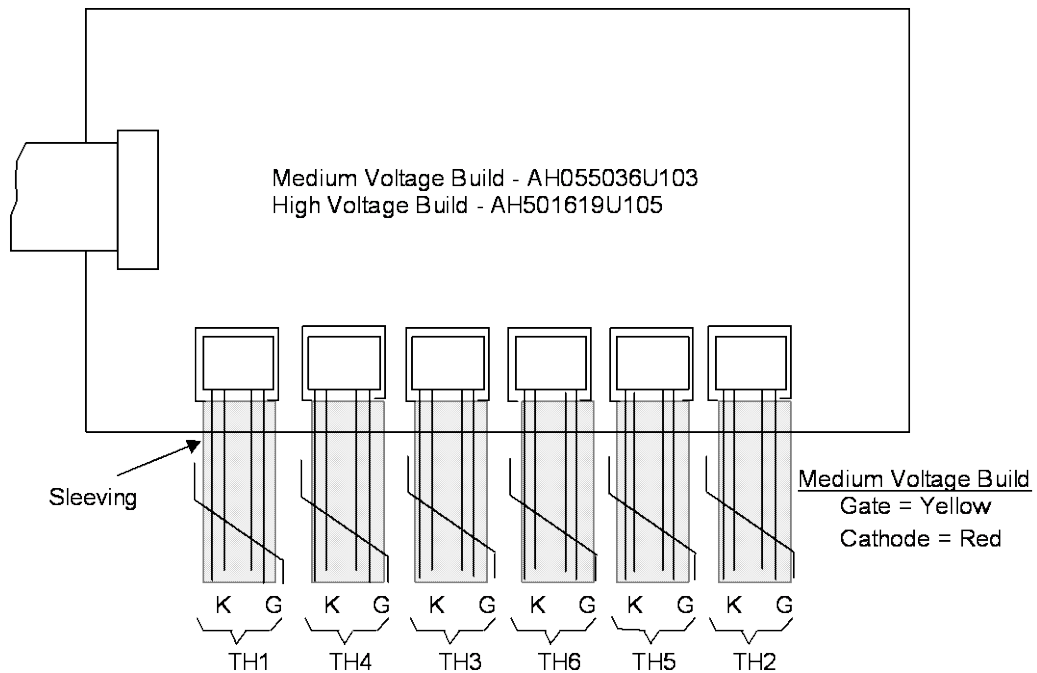

OPTOISOLATOR TRIGGER BOARD TERMINAL ASSIGNMENT

4 Quad

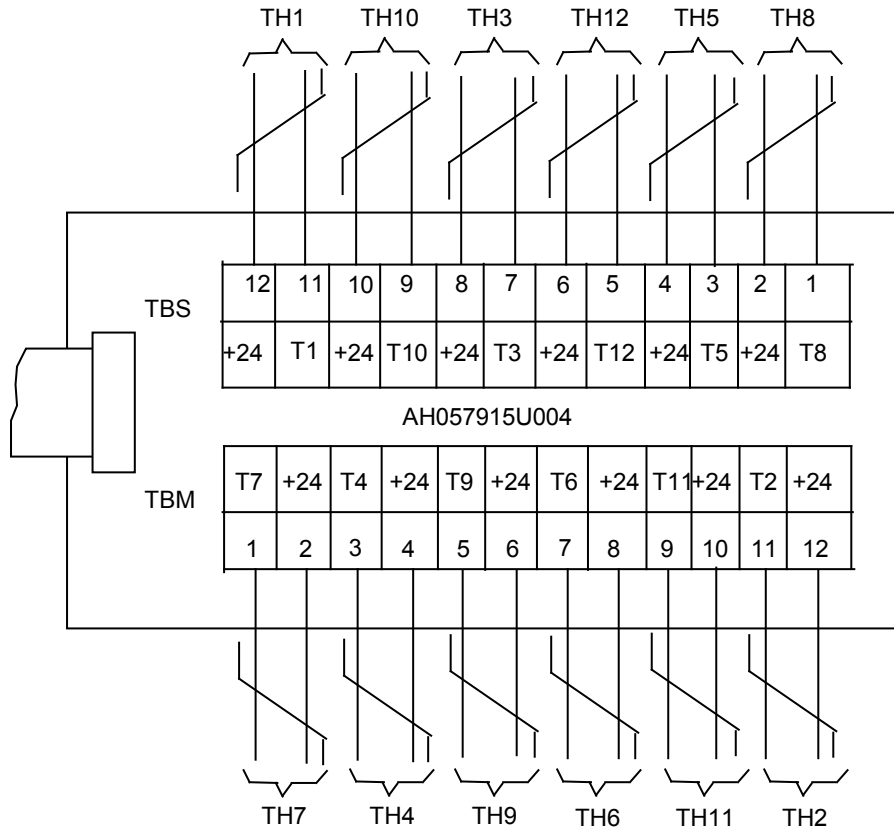

2 Quad

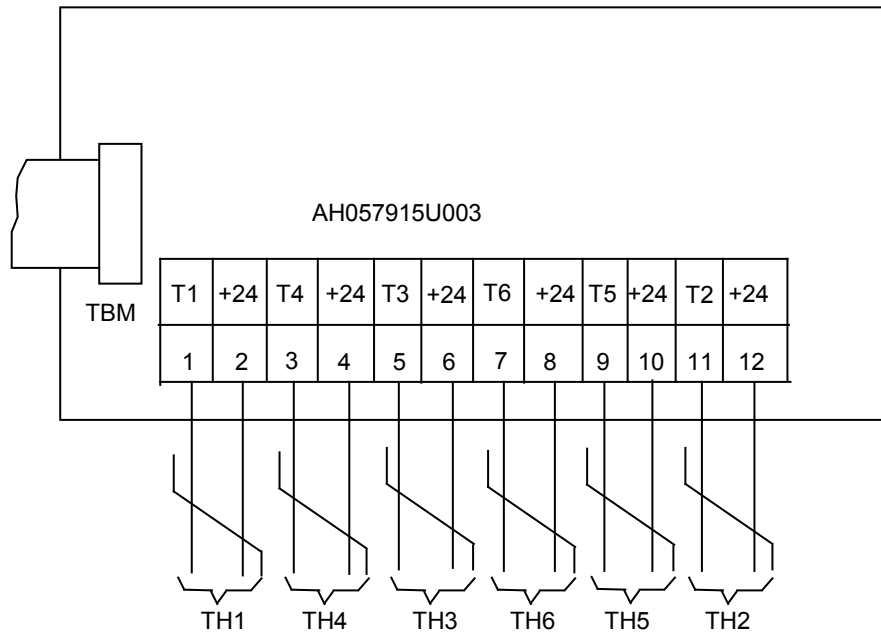

OPTOISOLATOR FIRING BOARD TERMINAL LAYOUT AND DIMENSIONS

Version 1

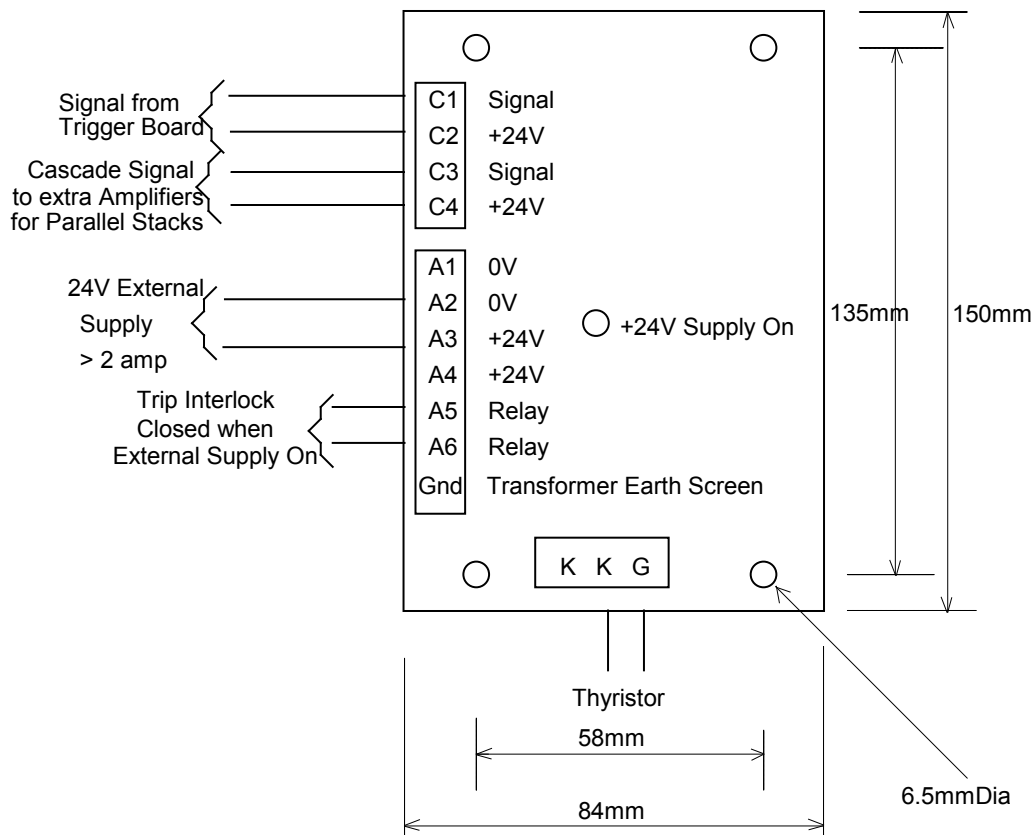

Version 2

In version 2 the PCB has been re-tracked on a different software package and the components updated to Standard Parts. This gives the following differences.

- 1) The PCB is slightly narrower (79mm) but fits on the same fixing centres;
- 2) Terminal Block A is split into two parts A1 to A4 and A5, A6 & Earth. This is to enable the use of the Relay on AC Supplies up to 240 Vac where previously clearances were inadequate;
- 3) There is now an extra terminal between A6 & Earth which is unused;
- 4) Radial Electrolytic Capacitors are used instead of Axial;
- 5) The add-on modification has been incorporated into the Circuit.

The functionality of the PCB is the same as before.

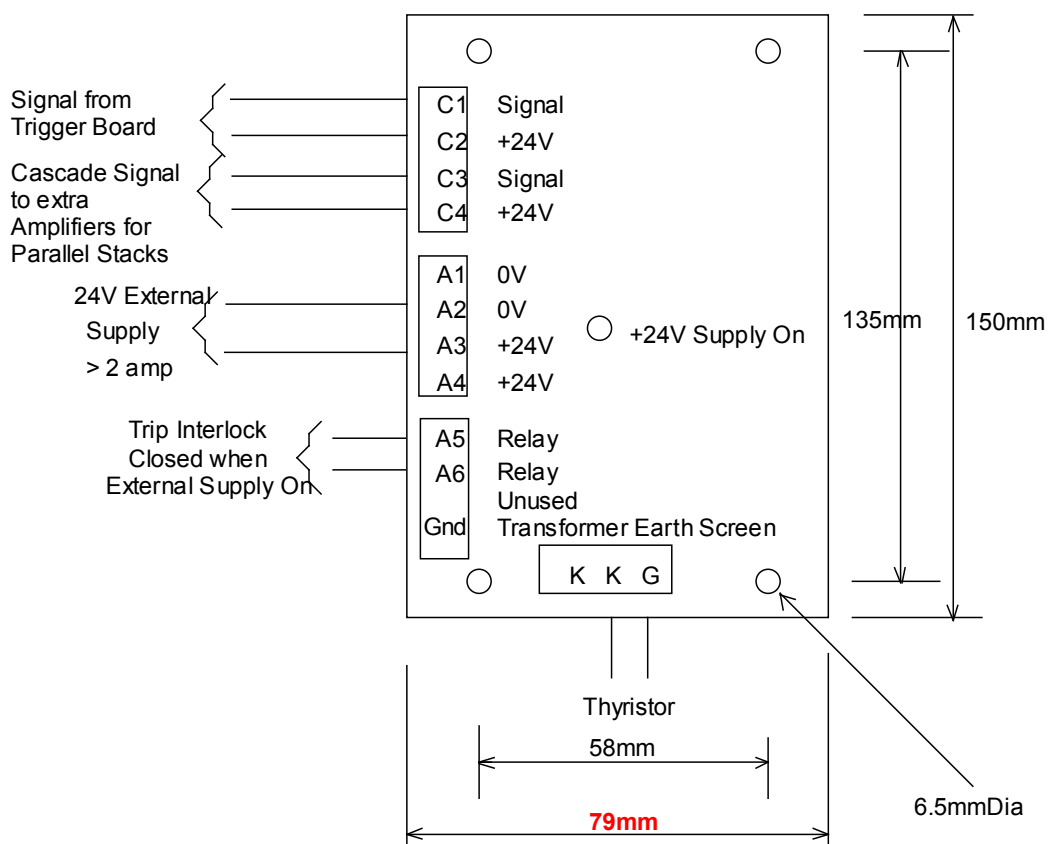

Product Code

DC590+ Series External Stack Controllers

		Block 1	Block 2	Block 3	Block 4
Example ▶		598P	- 23 2600 1 0	- A P 00	- U 0 A 0
Product Family	DC590+ Series Digital Drive - regen External Stack	598P			
	DC591+ Series Digital Drive - non-regen External Stack	599P			
Current / Power Rating	Supply Voltage				
	Output Current (A)				
	Frame Size				
	110-220V 3ph		23		
	60	1			
	120	1	2600	1	
	220-500V 3ph		53		
	60	1			
Auxiliary Supply	Universal 115V-230V 1ph (60 Amp rating only)				0
	115V 1ph (120 Amp rating only)				1
	230V 1ph (120 Amp rating only)				2
	120	1	2600	1	
					3120
					3120
					2600
					3120
					2600
					3120
Trigger Option	Amplifiers			A	
	Trigger (110-220v & 220-500v supply only)			T	
Mechanical Style	Panel Mounting				P
Special Options	None				00
	Documented special options (01-99) (Refer to local sales office)				
Language	English (50/60Hz)				U
	German				D
	Spanish				E
	French				F
	Italian				I
Keypad	None				0
	6901 keypad fitted				4
Speed Feedback	Analog Tacho				A
	Glass Fiberoptic encoder				G
	Plastic Fiberoptic encoder				P
	Armature Voltage				V
	Wire-ended Encoder				W
Communications	None				0
	ControlNet				C
	DeviceNet				D
	Ethernet				E
	Link				L
	ModBus +				M
	CanOpen				N
	Profibus				P
	RS485/RS422				R

LEGACY PRODUCT CODE

Block	Variable	Description
1	XXXX	Product 598P : 590+ External Stack Controller 4Q DC Drive 599P : 591+ External Stack Controller 2Q DC Drive
2	XXXX	Four Digits describing the Maximum Field DC Current Output. 0060 = 60 Amps 0120 = 120 Amps
3	XXX	Three Digits describing the Nominal 3 Phase Supply Voltage. 240 = 110 to 240 Vac $\pm 10\%$ 50/60Hz. – Low Voltage Build. 500 = 220 to 500 Vac $\pm 10\%$ 50/60Hz. – Medium Voltage Build. 690 = 380 to 690 Vac $\pm 10\%$ 50/60Hz. – High Voltage Build.
4	XXXX	Four Digits describing the Mechanical Package Style. <i>First Two Digits</i> <i>Livery</i> 00 Standard 05 Distributor <i>Third Digit</i> <i>Firing Amplifier</i> T Trigger (110-220v & 220-500v supply only) A Power Amplifier <i>Fourth Digit</i> <i>Operator Station</i> 0 No Opstation 1 6901 Opstation
5 through 7		As 590+.
8	XXX	Three Digits defining the required Auxiliary Supply Voltage. 0 = Universal Supply. 110 to 240 Vac $\pm 10\%$ 50/60Hz. 60 Amp Product only. 115 = 110 to 120 Vac $\pm 10\%$ 50/60Hz. 120 Amp Product requirement. 230 = 220 to 240 Vac $\pm 10\%$ 50/60Hz. 120 Amp Product requirement.
9	XXX	Special Options.

CERTIFICATION

Introduction

The stack controller is certified as being compliant with the regulated market requirements in:

Europe

Drives are CE certified as being compliant with

- The Low Voltage Directive 2006/95/EC

EUROPE

What are the European Directives?

The Directives are created to allow manufacturers to trade freely within the EEC territory through technical harmonisation of entire product sectors, and by guaranteeing a high level of protection of public interest objectives. This is done by creating a CE marking **CE**, a "trade symbol" showing that the technical requirements and those for safety and health are met.

Business and industry are given a wide choice of how to meet their obligations. The European standards bodies have the task of drawing up technical specifications. Compliance with harmonised standards, of which the reference numbers have been published in the Official Journal and which have been transposed into national standards, provides presumption of conformity to the corresponding essential requirements of the EC directives.

Manufacturers are free to choose any other technical solution that provides compliance with the essential requirements. Compliance with harmonised standards remains voluntary and offers one route to complying with these essential requirements.

The Declaration of Conformity signed by the companies nominated Compliance Officer is certification that the apparatus to which it refers meets the requirements of **all** the relevant European directives.

Compliance with harmonised standards provides a "presumption of conformity" and is the route which has been adopted by Parker SSD Drives.

CE Marking for the Low Voltage Directive (LVD) 2006/95/EC

The Low Voltage Directive (LVD) 2006/95/EC seeks to ensure that electrical equipment within certain voltage limits provides both a high level of protection for European citizens and enjoys a Single Market in the European Union. The Directive covers electrical equipment designed for use with a voltage rating of between 50 and 1000V for alternating current and between 75 and 1500V for direct current. For most electrical equipment, the health aspects of emissions of Electromagnetic Fields are also under the domain of the Low Voltage Directive.

The LVD is one of the oldest Single Market Directives which, in broad terms, provides both a conformity assessment procedure to be applied to equipment before being placed on the Market, and Essential Health Safety Requirements (EHSRs) which such equipment must meet either directly or by means of compliance with harmonized standards.

For electrical equipment within its scope, the Directive provides 'The Requirements' with respect to health and safety covering all risks, thus ensuring that electrical equipment is safe in its intended use.

In respect of conformity assessment, there is no third party intervention, as the manufacturer undertakes the conformity assessment. However, there are so-called "Notified Bodies" under the Directive, which may be used to provide reports in response to a challenge by a national authority as to the conformity of the equipment.

When installed in accordance with this manual, the product is CE marked by Parker SSD Drives in accordance with the Low Voltage Directive

Parker SSD Drives' certification (DoC) is supported by tests undertaken in accordance with harmonised standard BS EN61800-5-1

CE Marking for the EMC Directive 2004/108/EC

EMC

Since this stack controller is only a component part and incomplete in construction it is the responsibility of the customer to ensure compliance to the relevant international standards.

EMC General Installation Considerations

Earthing Requirements

IMPORTANT *Protective earthing always takes precedence over EMC screening.*

Protective Earth (PE) Connections

NOTE IN ACCORDANCE WITH INSTALLATIONS TO EN60204, ONLY ONE PROTECTIVE EARTH CONDUCTOR IS PERMITTED AT EACH PROTECTIVE EARTH TERMINAL CONTACTING POINT.

Local wiring regulations take precedence and may require the protective earth connection of the motor to be connected locally, i.e. not as specified in these instructions. This will not cause shielding problems because of the relatively high RF impedance of the local earth connection.

EMC Earth Connections

For compliance with EMC requirements, we recommend that the “0V/signal ground” be separately earthed. When a number of units are used in a system, these terminals should be connected together at a single, local earthing point.

Control and signal cables for the encoder, all analogue inputs, and communications require screening with the screen connected only at the VSD (Variable Speed Drive) end. However, if high frequency noise is still a problem, earth the screen at the non-VSD end via a 0.1µF capacitor.

NOTE CONNECT THE SCREEN (AT THE VSD END) TO THE VSD PROTECTIVE EARTH POINT, AND NOT TO THE CONTROL BOARD TERMINALS.

Cabling Requirements

Planning Cable Runs

- Keep electrically noisy and sensitive cables apart.
- Keep electrically noisy and sensitive parallel cable runs to a minimum. Separate parallel cable runs by at least 0.25 metres. For runs longer than 10 metres, separation should be increased proportionally. For example if the parallel runs were 50m, then the separation would be $(50/10) \times 0.25\text{m} = 1.25\text{m}$.
- Sensitive cables should cross noisy cables at 90°.
- Ensure EMC filter input and output cables are separately routed and do not couple across the filter.

598/599P EXTERNAL STACK CONTROLLER

EC DECLARATIONS OF CONFORMITY

Date CE marked first applied: 01/04/01

Low Voltage Directive

In accordance with the EEC Directive 2006/95/EC

We Parker SSD Drives, address as below, declare under our sole responsibility that the above Electronic Products when installed and operated with reference to the instructions in the Product Manual

(provided with each piece of equipment), is in accordance with the relevant clauses from the following standard:-

EN50178 (1998)

The drive is CE marked in accordance with the low voltage directive for electrical equipment and appliances in the voltage range when installed correctly.

MANUFACTURERS DECLARATIONS

Machinery Directive

The above Electronic Products are components to be incorporated into machinery and may not be operated alone.

The complete machinery or installation using this equipment may only be put into service when the safety considerations of the Directive 2006/42/EC are fully adhered to.

Particular reference should be made to EN60204-1 (Safety of Machinery - Electrical Equipment of Machines).

All instructions, warnings and safety information of the Product Manual must be adhered to.

Since the potential hazards are mainly electrical rather than mechanical, the drive does not fall under the machinery directive. However, we do supply a manufacturer's declaration for when the drive is used (as a component) in machinery.



Dr Martin Payn (Conformance Officer)

Parker Hannifin Manufacturing Ltd., Automation Group, SSD Drives Europe,
NEW COURTWICK LANE, LITTLEHAMPTON, WEST SUSSEX BN17 7RZ
TELEPHONE: +44 (0)1903 737000 FAX: +44 (0)1903 737100

Registered Number: 4806503 England. Registered Office: 55 Maylands Avenue, Hemel Hempstead, Herts HP2 4SJ

Parker Worldwide

AE – UAE, Dubai
Tel: +971 4 8127100
parker.me@parker.com

AR – Argentina, Buenos Aires
Tel: +54 3327 44 4129

AT – Austria, Wiener Neustadt
Tel: +43 (0)2622 23501-0
parker.austria@parker.com

AT – Eastern Europe, Wiener Neustadt
Tel: +43 (0)2622 23501 900
parker.easteurope@parker.com

AU – Australia, Castle Hill
Tel: +61 (0)2-9634 7777

AZ – Azerbaijan, Baku
Tel: +994 50 2233 458
parker.azerbaijan@parker.com

BE/LU – Belgium, Nivelles
Tel: +32 (0)67 280 900
parker.belgium@parker.com

BR – Brazil, Cachoeirinha RS
Tel: +55 51 3470 9144

BY – Belarus, Minsk
Tel: +375 17 209 9399
parker.belarus@parker.com

CA – Canada, Milton, Ontario
Tel: +1 905 693 3000

CH – Switzerland, Etoy
Tel: +41 (0)21 821 87 00
parker.switzerland@parker.com

CL – Chile, Santiago
Tel: +56 2 623 1216

CN – China, Shanghai
Tel: +86 21 2899 5000

CZ – Czech Republic, Klecany
Tel: +420 284 083 111
parker.czechrepublic@parker.com

DE – Germany, Kaarst
Tel: +49 (0)2131 4016 0
parker.germany@parker.com

DK – Denmark, Ballerup
Tel: +45 43 56 04 00
parker.denmark@parker.com

ES – Spain, Madrid
Tel: +34 902 330 001
parker.spain@parker.com

FI – Finland, Vantaa
Tel: +358 (0)20 753 2500
parker.finland@parker.com

FR – France, Contamine s/Arve
Tel: +33 (0)4 50 25 80 25
parker.france@parker.com

GR – Greece, Athens
Tel: +30 210 933 6450
parker.greece@parker.com

HK – Hong Kong
Tel: +852 2428 8008

HU – Hungary, Budapest
Tel: +36 1 220 4155
parker.hungary@parker.com

IE – Ireland, Dublin
Tel: +353 (0)1 466 6370
parker.ireland@parker.com

IN – India, Mumbai
Tel: +91 22 6513 7081-85

IT – Italy, Corsico (MI)
Tel: +39 02 45 19 21
parker.italy@parker.com

JP – Japan, Tokyo
Tel: +81 (0)3 6408 3901

KR – South Korea, Seoul
Tel: +82 2 559 0400

KZ – Kazakhstan, Almaty
Tel: +7 7272 505 800
parker.easteurope@parker.com

MX – Mexico, Apodaca
Tel: +52 81 8156 6000

MY – Malaysia, Shah Alam
Tel: +60 3 7849 0800

NL – The Netherlands, Oldenzaal
Tel: +31 (0)541 585 000
parker.nl@parker.com

NO – Norway, Asker
Tel: +47 66 75 34 00
parker.norway@parker.com

NZ – New Zealand, Mt Wellington
Tel: +64 9 574 1744

PL – Poland, Warsaw
Tel: +48 (0)22 573 24 00
parker.poland@parker.com

PT – Portugal, Leca da Palmeira
Tel: +351 22 999 7360
parker.portugal@parker.com

RO – Romania, Bucharest
Tel: +40 21 252 1382
parker.romania@parker.com

RU – Russia, Moscow
Tel: +7 495 645-2156
parker.russia@parker.com

SE – Sweden, Spånga
Tel: +46 (0)8 59 79 50 00
parker.sweden@parker.com

SG – Singapore
Tel: +65 6887 6300

SK – Slovakia, Banská Bystrica
Tel: +421 484 162 252
parker.slovakia@parker.com

SL – Slovenia, Novo Mesto
Tel: +386 7 337 6650
parker.slovenia@parker.com

TH – Thailand, Bangkok
Tel: +662 717 8140

TR – Turkey, Istanbul
Tel: +90 216 4997081
parker.turkey@parker.com

TW – Taiwan, Taipei
Tel: +886 2 2298 8987

UA – Ukraine, Kiev
Tel: +380 44 494 2731
parker.ukraine@parker.com

UK – United Kingdom, Warwick
Tel: +44 (0)1926 317 878
parker.uk@parker.com

US – USA, Cleveland
Tel: +1 216 896 3000

VE – Venezuela, Caracas
Tel: +58 212 238 5422

ZA – South Africa, Kempton Park
Tel: +27 (0)11 961 0700
parker.southafrica@parker.com

European Product Information Centre
Free phone: 00 800 27 27 5374
(from AT, BE, CH, CZ, DE, EE, ES, FI, FR, IE, IL, IS, IT, LU, MT, NL, NO, PT, SE, SK, UK)

© XXXX to YYYY Parker Hannifin Corporation. All rights reserved.



Parker Hannifin Manufacturing Limited
Automation Group, SSD Drives Europe,
New Courtwick Lane,
Littlehampton, West Sussex BN17 7RZ
United Kingdom
Tel.: +44 (0) 1903 721000
Fax: +44 (0) 1903 737100
www.parker.com/ssd



* H A S O O 8 4 1 - 0 3 *