

Gemini 50-Pin Connector to Flying Leads Cable

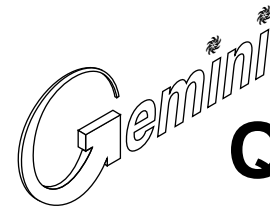

Quick Reference Guide

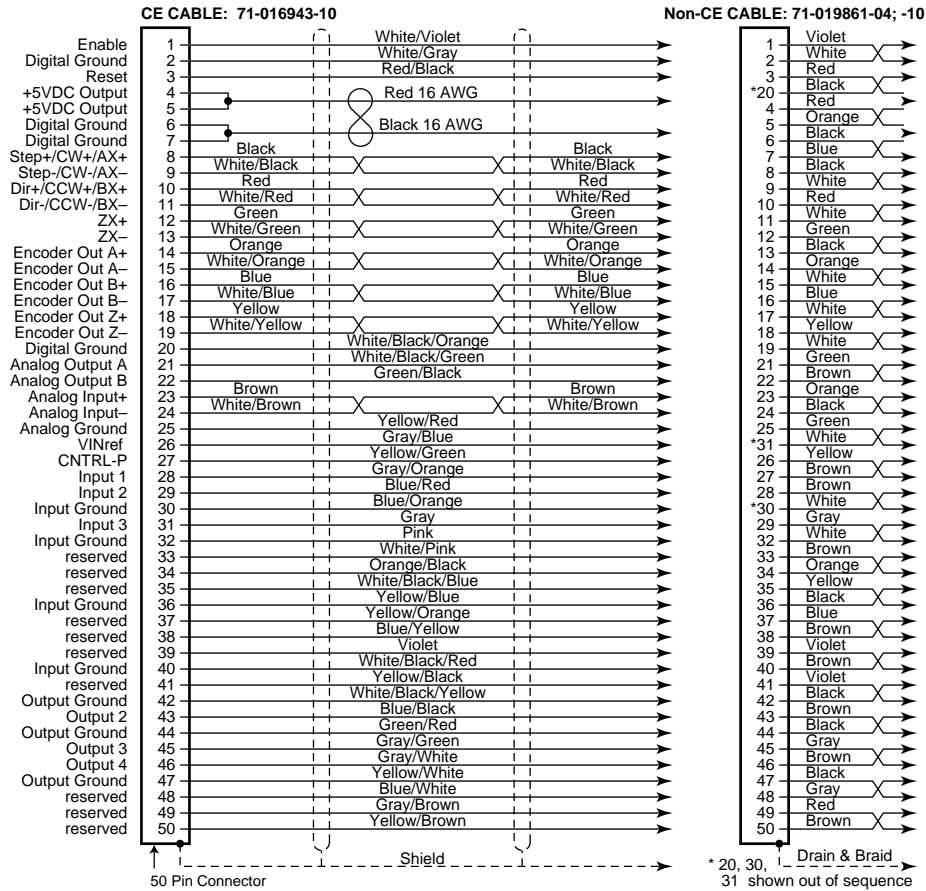
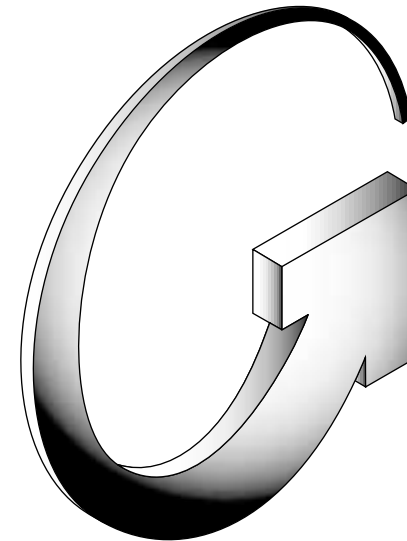

Protective Circuits

- Short Circuit Protection
- Inrush Current Protection
- Drive Overttemperature Protection
- Motor Overttemperature Protection
- Undervoltage Protection
- Overvoltage Protection
- Current Foldback
- Regeneration Protection

Environmental Specifications

- Operating Temperature: Still Air: 45°C (113°F)
Moving Air: 50°C (122°F)
- Storage Temperature: -40°C - 85°C (-40°F - 185°F)
- Humidity: 0 - 95%, non-condensing
- Shock: 15g, 11msec half sine
- Vibration: 10 - 2000 Hz at 2g

Troubleshooting

- Commonly used status commands (binary status bits are numbered 1 to n, from left to right):
- TERRLG Error log reports the last 10 error conditions (cleared with CERRLG).
 - TAS General report, including fault conditions.
 - TASX Additional report of conditions not covered with TAS.
 - TCS If TASX bit #7 or bit #28 is set, you can identify the cause with TCS.
 - TINO Bit #6 indicates status of Enable input ("1" = OK to enable drive).
 - TIN Status of digital inputs, including end-of-travel inputs.
 - TOUT Status of digital outputs.

You must configure all motor parameters. Be sure to follow the drive configuration procedure (see *Chapter 2 Installation*).

Any fault condition causes the drive to shut down.

The drive can not be enabled (DRIVE1) unless the Enable input is grounded and the Reset input is not grounded.

Use one of three methods to reset the drive (all command settings are remembered after reset):
 Issue the RESET command.
 Momentarily close the Reset input.
 Cycle power to the drive.

Gemini GV6 Series Digital Servo Controller/Drives

Compumotor Division
 Parker Hannifin Corporation
 p/n 88-018365-01 B (effective February 1, 2002)



RS-232/485 Connector – Configuration Port

To configure all drive parameters, connect a PC or HPC to this port. Use Motion Planner or Pocket Motion Planner for drive configuration. (Not ASCII protocol.)

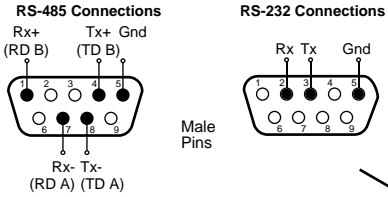

Gemini GV6 Digital Servo Controller/Drive

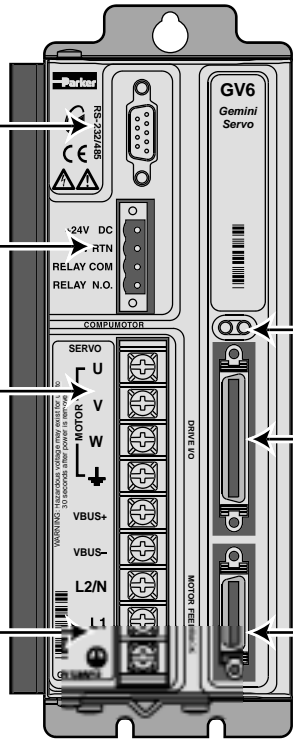

LEDs

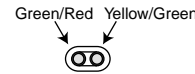

LED Color:	Right	Indicated State
Off	Yel	Initialization
Red (flash)	Off	Awaiting flash download
Red (flash)	Yel (flash)	Programming flash memory
Red	Grn	Keep alive mode
Grn	Grn (flash)	Incoming steps (variable rate)
Grn	Yel/Grn (flash)	Autorun mode
Red	Off	Drive not enabled
		Drive faulted
Grn	Off	Drive ready

+24VDC/Relay Connector

User supplies +24VDC for "keep alive" power to drive: 19.2 – 28.8 VDC 500 mA minimum

When drive is enabled, it holds relay closed.

Relay rating: 5A at 24VDC or 120VAC.

If drive is faulted or disabled, relay will open. (Typical use: control of motor brake.)

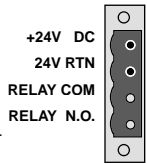

Motor Output Connections

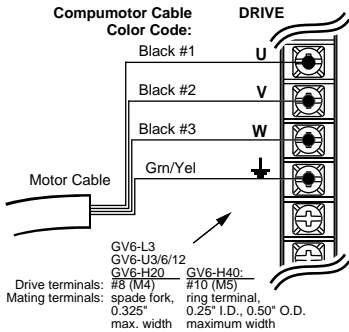

AC Input Connections

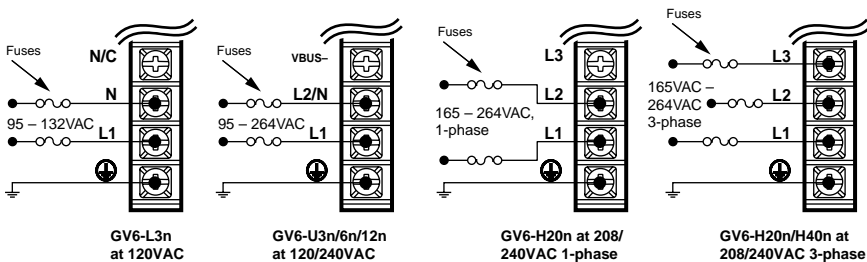

Multiple Drive Connections

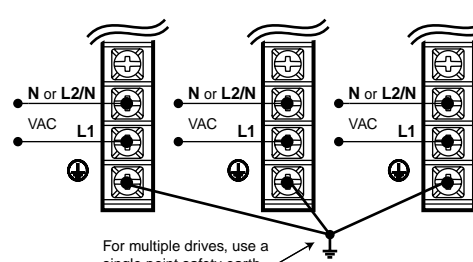

50 Pin DRIVE/I/O Connector

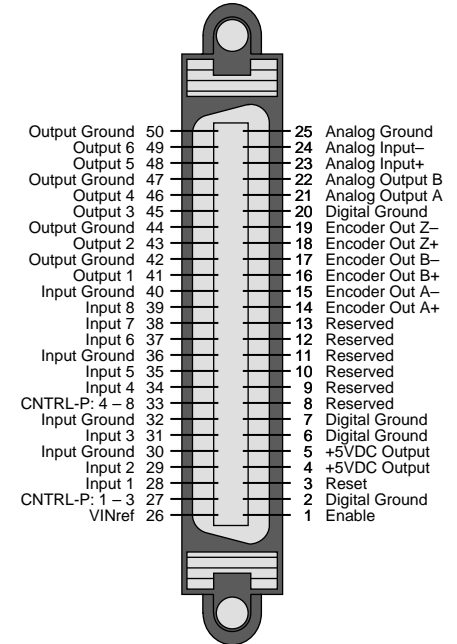

26 Pin MOTOR FEEDBACK Connector

