

Natural Gas Solutions

CNG Low Pressure Valves



Customer Value Proposition:

Parker Fluid Control Division (FCD) is actively involved in providing system solutions for the transportation market that support alternative fuel applications.

Parker FCD's current product offering features both high and low pressure valves for CNG applications. Our in-house design, test, and validation capabilities also allow us to offer more complex, customized solutions to meet unique customer requirements. Our low pressure valves hold the ECE R110 approval, which makes the valve suitable for vehicle on-board applications.



Contact Information:

Parker Hannifin Corporation
Fluid Control Division
95 Edgewood Avenue
New Britain, CT 06051

1 800 825 8305
parkerfcd_sales@parker.com

www.parker.com/fcd



Product Features

- 2 Way Normally Closed
- Brass Body, FKM & ECO Seals
- ECE R110 Approved
- Minimum Pressure Differential is 10PSI and Maximum Differential is 250PSI
- Media Temperature: -40°F to 185°F
- Power Consumption: 10 Watts
- 12VDC and 24VDC
- Process Connections: 3/8" & 1/2" NPT

ENGINEERING YOUR SUCCESS.

Low Pressure CNG Valve

Port Size	Orifice Size in.	Flow Factor Cv	Operating Pressure Differential (MOPD) PSI		Min. Media Temp. °F	Max. Media Temp. °F	Power (Watt)	Seal	Valve Number
			Min.	Max.					
3/8" NPT	1/2"	2.4	10	250	-40	185	10	FKM ECO	73212BN3TNP8F7J222**
1/2" NPT	1/2"	2.8	10	250	-40	185	10	FKM ECO	73212BN4TNP8F7J222**

** Valve number ending in "C1" = 12VDC
Valve number ending in "C2" = 24VDC

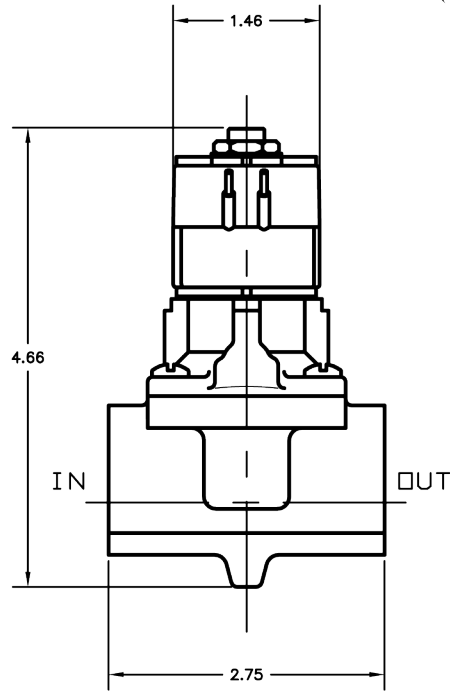

Dimensions for Reference Only.

