

Modular Lean Solutions

Display Stands for Day by the Hour Tracking

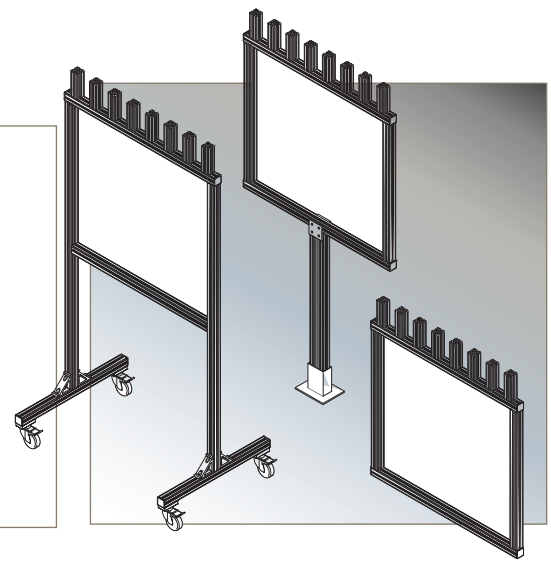

Track. Audit. Execute.

Visual management and day by the hour tracking boards are lean fundamentals and should be deployed across all key processes of an organization to maximize customer satisfaction, efficiency, effectiveness and safety.

Using simple visual devices in the workplace, as simple as the color of a plastic cup, can make all the difference in helping key personnel across an entire shop floor keep track of ongoing operation status, trends and goals.

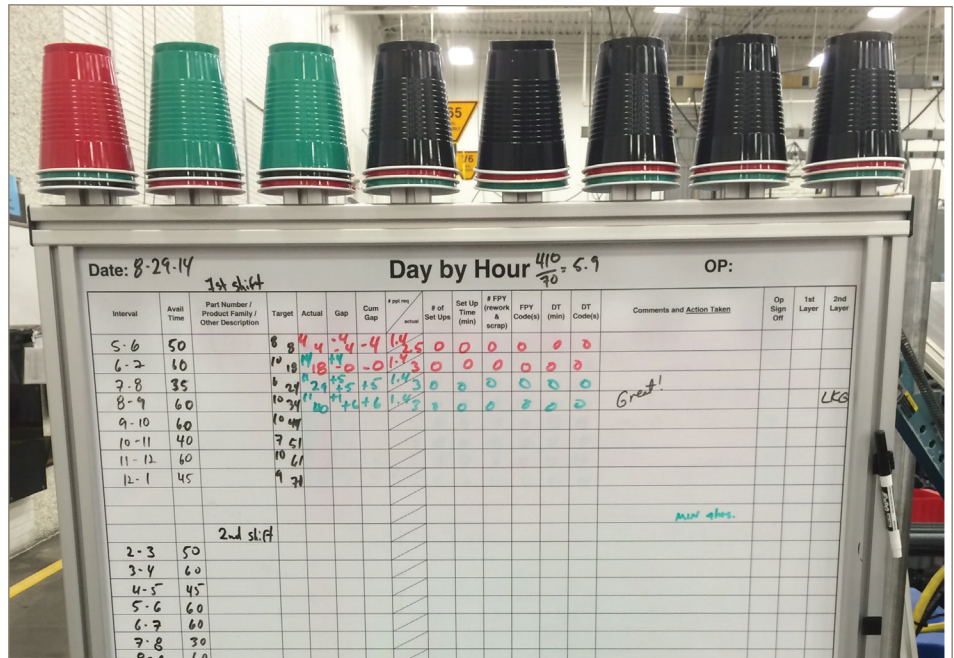

Contact Information:

Parker Hannifin Corporation
Electromechanical Automation Division
 email ipsorders@parker.com
 www.parkermotion.com/ips

Two Locations to Serve You:

135 Quadral Drive
 Wadsworth, OH 44281
 Phone 800.333.4932
 Fax 330.334.2350

5500 Business Park Drive
 Rohnert Park, CA 94928
 Phone 800.358.9070
 Fax 707.584.8029



Track... In a lean workplace environment, visual management and team improvement boards make the tracking of the current condition obvious at a glance. Utilizing visual information helps us to run our businesses by creating rapid recognition of problems (waste).

Audit... Displayed data allows live auditing and enables quick reaction to abnormal situations.

Execute... Day by the hour tracking ensures visual data to support problem-solving activities and the PDCA cycle. Effective execution of the PDCA cycle results in waste elimination and continuous improvement.

Convenient, Standard, Modular...

Implementing a visual workplace requires a significant time and effort investment to setup and to maintain.

To simplify your lean and quality journey, Parker has created a series of standard, day by the hour boards using our modular T-slot aluminum framing system, also known as IPS.

These pre-configured designs simplify your implementation by providing a single part number to order your day by the hour board. Units can be provided either fully assembled or as fully machined kits for easy on-site assembly.

ENGINEERING YOUR SUCCESS.

Modular Lean Solutions

Display Stands for Day by the Hour Tracking

Choose the configuration tailored to the specific needs of your application:

- **Floor mount, rolling mobile unit, or wall mount display styles**
- **Available with Andon Post Option for ahead or behind indication or without option**
- **Choice of polycarbonate or black Trespa® backboard**

With Parker Modular Lean Solutions, there's no need to spend time designing your day by the hour boards. Simply order for quick delivery and start using immediately to uncover problems and drive solutions.

Ordering Information

Fill in an order code from each of the numbered fields to create a complete model order code.

① ② ③ ④ ⑤ ⑥

Order Example: 71 - 1 1 3 - P K

- Display Stand Series**
71 Day by the Hour Tracking Display Stands
- Board Orientation**
1 Floor Mount
2 Mobile
3 Wall Mount
- Andon Post Option**
1 Andon Post Option (8 total)
2 No Andon Post Option
- Board Size**
3 3' x 3' (approximate)
- Board Type**
P Clear Poly Board for Easel Pad
B Black Trespa Board for Easel Pad
N Ready for Special Board
- Package**
K Kit
A Shipped pre-assembled (except caster sub assemblies, which customer will have to mount to the unit)

Floor Mount

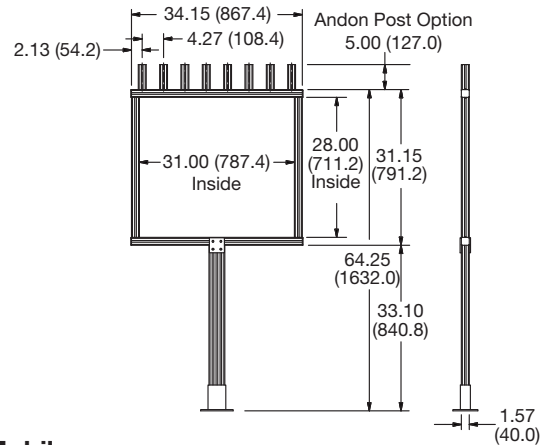

Mobile

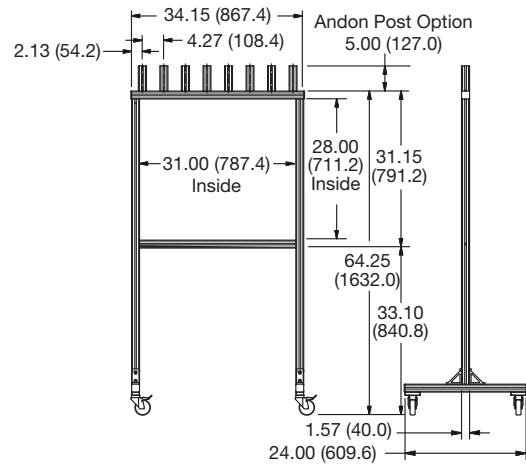

Wall Mount

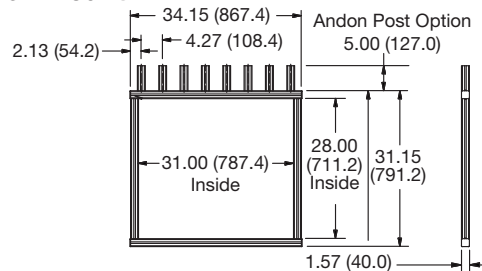

Standard designs don't solve your problem?

Contact applications engineering at
IPSQuotes@parker.com or call 800.333.4932



ENGINEERING YOUR SUCCESS.