

General Description

A

Series D3A directional control valves are high performance, 4-chamber, direct operated, air pilot controlled, 4-way valves. They are available in 2 or 3-position and conform to NFPA's D05/CETOP 5 mounting patterns.

Features

- Low pilot pressure required – 4.1 Bar (60 PSI) minimum.
- High flow, low pressure drop design.

Specifications

Mounting Pattern	NFPA D05, CETOP 5, NG 10
Maximum Pressure	Operating: 345 Bar (5000 PSI) Tank Line: 34 Bar (500 PSI)
Maximum Flow	See Spool Reference Chart
Pilot Pressure	Air Minimum 4.1 Bar (60 PSI) Air Maximum 6.9 Bar (100 PSI)

Air Operated

Shift Volume. The air pilot chamber requires a volume of 1.8 cc (.106 in.³) for complete shift from center to end.

Pilot Piston. The pilot piston area is 506 mm² (.785 in.²). Pilot piston stroke is 3.4 mm (.135 in.).

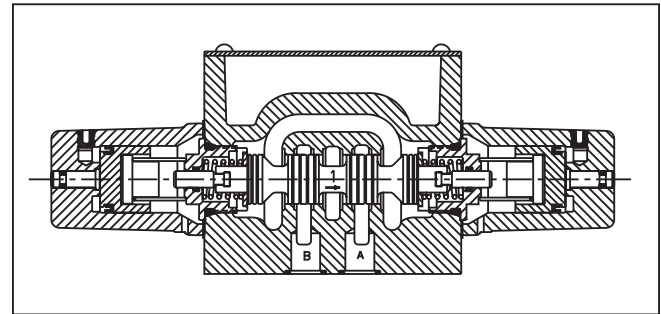
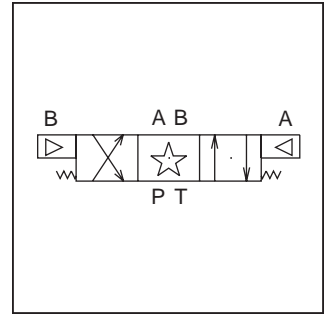
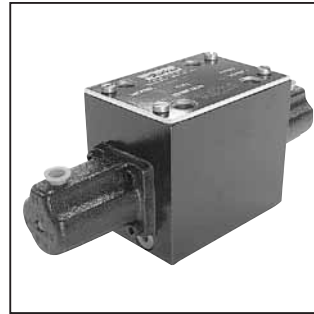

Response Time* (ms)

Signal to 95% spool stroke measured at 172 Bar (2500 PSI) and 75 LPM (20 GPM)

Pilot Pressure	Pull-In	Drop-Out
60 PSI	23.0 ms	23.0 ms
100 PSI	19.0 ms	38.0 ms

* Chart is for reference only. Response time will vary with pilot line size, length, air pressure and air valve flow capacity (Cv).

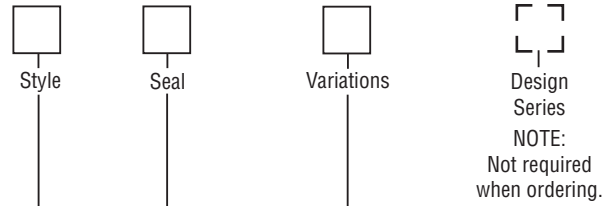
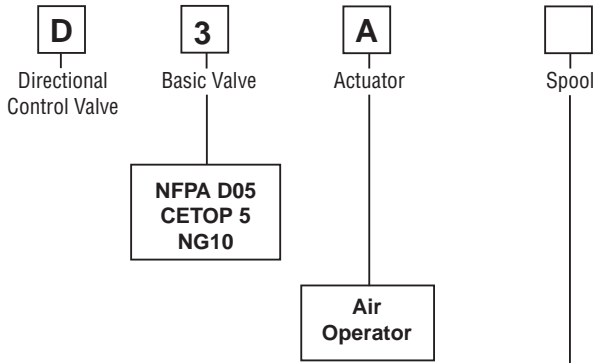

Code	Symbol	Code	Symbol
1		20*	
2		30†	
4		81	
8*		82	
9†			

* 8 and 20 spools have closed crossover.
 † 9 and 30 are open crossover.

Valve schematic symbols are per NFPA/ANSI standards, providing flow P to A when energizing operator A. Note operators reverse sides for #8 and #9 spools. See installation information for details.

Code	Description	Symbols
B #	Single operator, two position spring offset. P to A and B to T in offset position.	
C	Double operator, three position, spring centered.	
D #	Double operator, two position, detent.	
E	Two position, spring centered. P to B and A to T in shifted position.	
H #	Single operator, two position, spring offset. P to B and A to T in offset position.	
K	Two position, spring centered. P to A and B to T in shifted position.	

B, D & H styles available with 20 and 30 spools only.

Indicates air pilot.

This condition varies with spool code.

Mounting Bolt Kits

UNC Bolt Kits for use with D3A Directional Control Valves & Sandwich Valves					
		Number of Sandwich Valves @ 2.00" (50mm) thickness			
		0	1	2	3
D3A	Standard:	BK98 1.62"	BK141 3.50"	BK142 5.50"	BK143 7.50"
	Metric:	BKM98 40mm	BKM141 90mm	BKM142 140mm	BKM143 190mm

NOTE: All bolts are SAE grade 8, 1/4-20 UNC-2A thread, torque to 16 Nm (12 ft-lbs).

Valve Weight: 4.1 kg (9 lbs.)
Seal Kit:
 Nitrile SKD3A
 Fluorocarbon SKD3AV

Bold: Designates Tier I products and options.

Non-Bold: Designates Tier II products and options. These products will have longer lead times.

Inch equivalents for millimeter dimensions are shown in (**)

A

Air Operated, Double Pilot

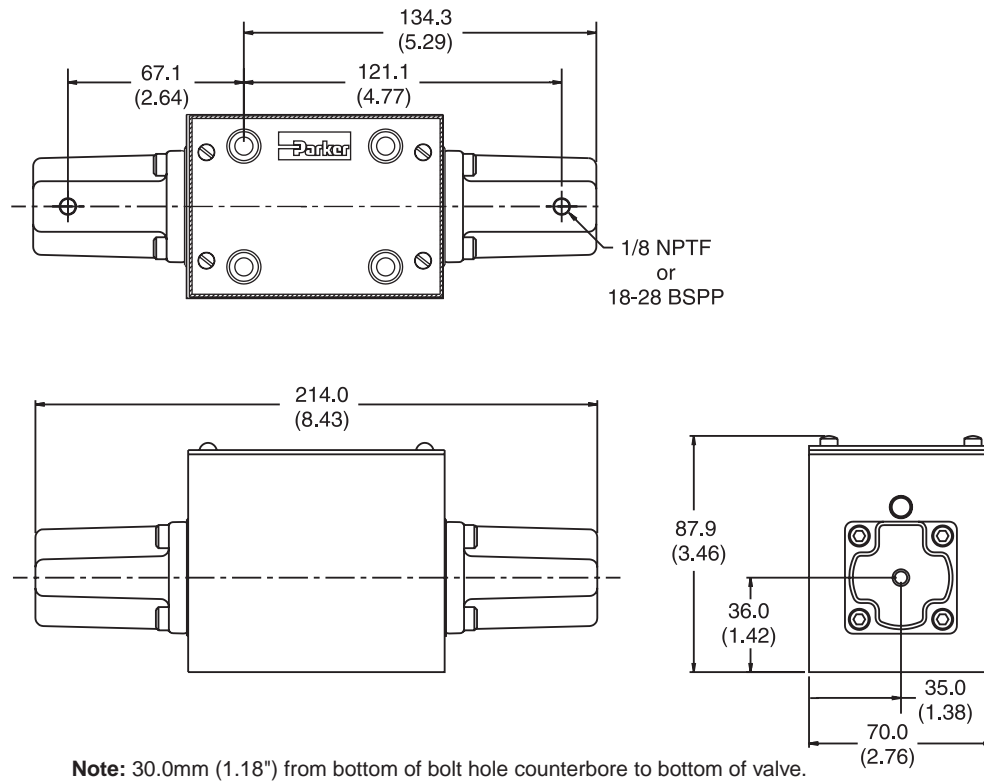

Air Operated, Single Pilot

