

CPC Check Valve Cartridge



- ◆ 3500 psi (241 bar) working pressure
- ◆ Flow rates to 50 gpm (189 l/min)
- ◆ Steel Construction
- ◆ Three standard spring pressures
- ◆ Three sizes based on flow

Features

Designed for hydraulic circuit applications where virtually zero leakage in the check direction is required. The drop-in cartridge design with soft poppet seal of molded nylon is available in three sizes with flow ratings of 10 gpm (38 l/min), 25 gpm (95 l/min), and 50 gpm (189 l/min) respectively.

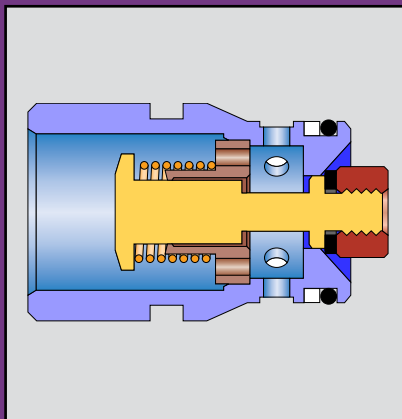

*Dimensions and Specifications

Model		A	B	C	D	E	F	G	H	J	K	L	M	N
CPC 10	In.	1.204	.248	.500	.629/.625	.250	.390	.745/.750	.437	.030	.300	1.20	.74	.62
	mm	30.6	6.3	12.7	16.0/15.9	6.4	9.9	18.9/19.0	11.0	.76	7.6	30.5	18.8	15.7
CPC 25	In.	1.776	.230	.680	.879/.875	.531	.520	1.004/1.000	.500	.025	.400	1.78	.99	.87
	mm	45.1	5.8	17.3	22.3/22.2	13.5	13.2	25.5/25.4	12.7	.64	10.2	45.2	25.1	22.1
CPC 50	In.	2.291	.284	1.060	1.316/1.312	.592	.600	1.504/1.500	1.000	.025	.476	2.29	1.49	1.30
	mm	58.2	7.2	26.9	33.4/33.3	15.1	15.2	38.2/38.1	25.4	.64	12.1	58.2	37.8	33.0

Notes:

- Decimal dimensions are +/- .015 in. (.38 mm).
- Ratings, specifications, and dimensions are subject to change without notice.
- Part configurations are typical and do not necessarily represent actual appearance.
- Consult factory for certified cavity drawing.

CPC Flow Direction:

