



## Vane pumps

### Service information

vane-type triple pump / Flügelzellen-Dreifachpumpe

pompe triple à palettes / pompa tripla a palette

tipo bomba de paletas triple

## T7EDB - T7EDBS

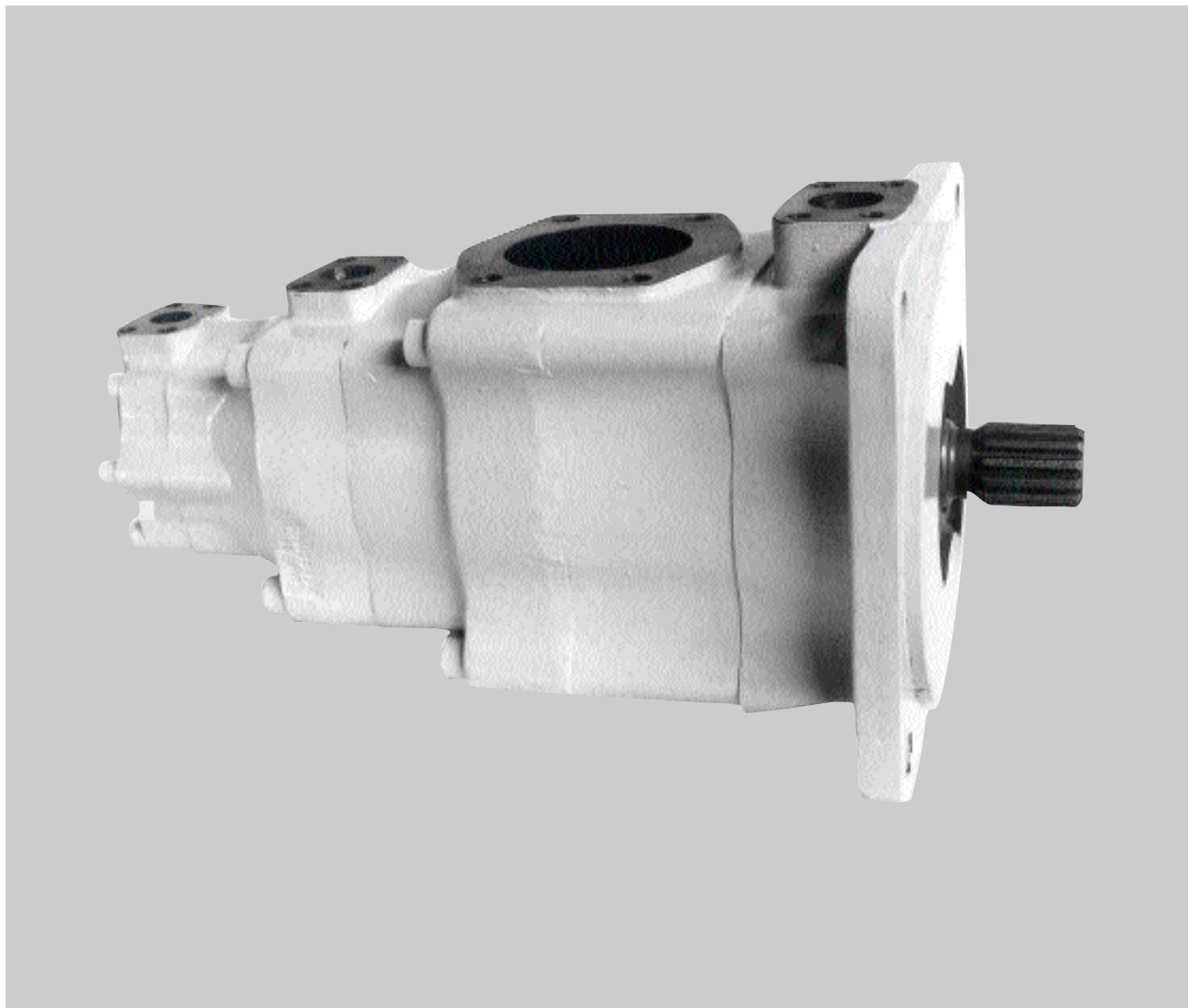

Publ. S1 - ML0622 - C

09 / 2004 / FB

Replaces : S1 - ML0622 - B

L25 - 10622 - 3

Recommended repair kits and assy's are bold printed  
 Empfohlene Austausch - Baugruppen sind fett gedruckt  
 Les pochettes de rechange recommandées sont imprimées en caractères gras  
 I kit di ricambio consigliati sono indicati in grassetto  
 Los juegos de reparacion recomendados y los conjuntos, estan en negrita

	Item - Pos. - Réf. - Pos.		
	49	52	54
Mounting torque			
Anziehdrehmoment	300 Nm	190 Nm	80 Nm
Couple de serrage	221 ft.lbs	140 ft.lbs	60 ft.lbs
Coppia di serraggio			
Par de apriete			

# T7EDB - T7EDBS

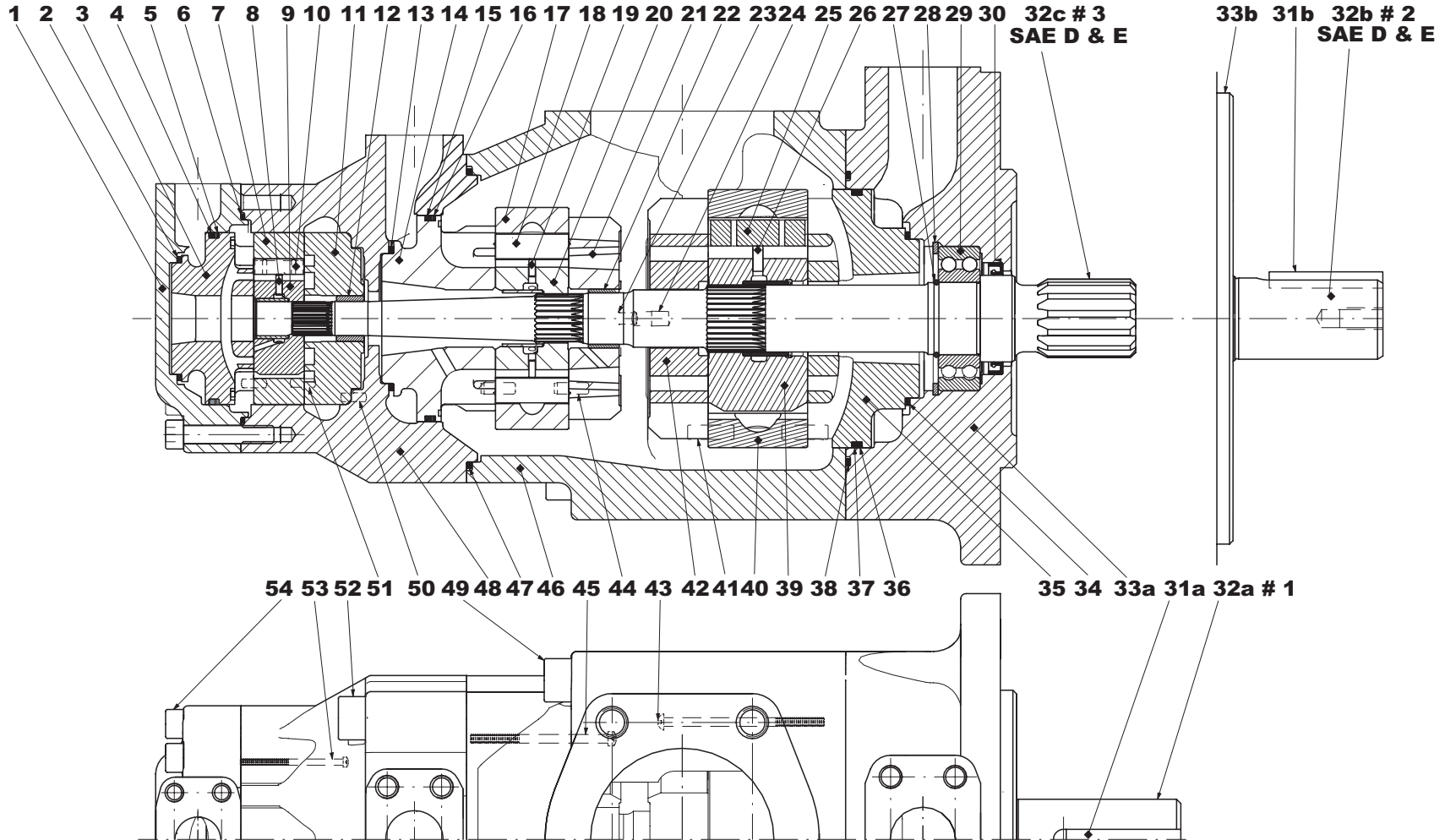

Item Pos. Réf. Pos. Pos.	Description Descrizione	Benennung Descripcion	Description		Part N° Teil Nr. Code N° Cod. N° Referencia T7EDB	Part N° Teil Nr. Code N° Cod. N° Referencia T7EDBS	Qty Stück Qté Q.tà Cant.	
1	End cap 1" (metric) <i>Coperchio 1" (metrica)</i>	Deckel 1" (Metrisch) <i>Tapa 1" (metrico)</i>	Chapeau 1" (métrique)		034.71327		1	
	End cap 1" (UNC) <i>Coperchio 1" (UNC)</i>	Deckel 1" (UNC) <i>Tapa 1" (UNC)</i>	Chapeau 1" (UNC)			034.48579	1	
	End cap 3/4" (metric) <i>Coperchio 3/4" (metrica)</i>	Deckel 3/4" (Metrisch) <i>Tapa 3/4" (metrico)</i>	Chapeau 3/4" (métrique)		034.66765		1	
	End cap 3/4" (UNC) <i>Coperchio 3/4" (UNC)</i>	Deckel 3/4" (UNC) <i>Tapa 3/4" (UNC)</i>	Chapeau 3/4" (UNC)			034.66523	1	
	Sq. section seal <i>Guarnizione</i>	Dichtring <i>Junta seccion cuadrada</i>	Joint section carrée	CD	691.10229		1	
	Port plate-pressure <i>Piatto distributore anter.</i>	Steuerplatte <i>Plato distribuidor-presión</i>	Plaque pression	C	034.66923		1	
4	Sq. section seal <i>Guarnizione</i>	Dichtring <i>Junta seccion cuadrada</i>	Joint section carrée	CD	691.10238		1	
5	Back-up ring <i>Anello anti-estrusione</i>	Stützring <i>Anillo</i>	Bague anti-extrusion	CD	618.00010.3		1	
6	Sq. section seal <i>Guarnizione</i>	Dichtring <i>Junta seccion cuadrada</i>	Joint section carrée	CD	671.10156		1	
7	Cam ring 002 <i>Anello camma 002</i>	Hubring 002 <i>Aro volumetrico 002</i>	Came 002	C	034.66909		1	
	Cam ring 003 <i>Anello camma 003</i>	Hubring 003 <i>Aro volumetrico 003</i>	Came 003	C	034.66910		1	
	Cam ring 004 <i>Anello camma 004</i>	Hubring 004 <i>Aro volumetrico 004</i>	Came 004	C	034.66911		1	
	Cam ring 005 <i>Anello camma 005</i>	Hubring 005 <i>Aro volumetrico 005</i>	Came 005	C	034.66912		1	
	Cam ring 006 <i>Anello camma 006</i>	Hubring 006 <i>Aro volumetrico 006</i>	Came 006	C	034.66913		1	
	Cam ring 007 <i>Anello camma 007</i>	Hubring 007 <i>Aro volumetrico 007</i>	Came 007	C	034.67063		1	
	Cam ring 008 <i>Anello camma 008</i>	Hubring 008 <i>Aro volumetrico 008</i>	Came 008	C	034.66914		1	
	Cam ring 009 <i>Anello camma 009</i>	Hubring 009 <i>Aro volumetrico 009</i>	Came 009	C	034.67383		1	
	Cam ring 010 <i>Anello camma 010</i>	Hubring 010 <i>Aro volumetrico 010</i>	Came 010	C	034.66915		1	
	Cam ring 011 <i>Anello camma 011</i>	Hubring 011 <i>Aro volumetrico 011</i>	Came 011	C	034.67461		1	
	Cam ring 012 <i>Anello camma 012</i>	Hubring 012 <i>Aro volumetrico 012</i>	Came 012	C	034.67032		1	
	Cam ring 014 <i>Anello camma 014</i>	Hubring 014 <i>Aro volumetrico 014</i>	Came 014	C	034.67409		1	
	Cam ring 015 <i>Anello camma 015</i>	Hubring 015 <i>Aro volumetrico 015</i>	Came 015	C	034.67034		1	
	8	Vane <i>Paletta</i>	Flügel <i>Paleta</i>	Palette	C	034.66917		12
	9	Pin-vane holdout <i>Pistoncino di sostentamento</i>	Stössel <i>Espiga empuje paleta</i>	Poussoir de palette	C	034.66991		12
10	Rotor ass'y <i>Insieme rotore</i>	Rotor <i>Conjunto rotor</i>	Rotor ass.	C	S24.49820		1	

Item Pos. Pos. Pos.	Description Descrizione	Benennung Descripcion	Description		Part N° Teil Nr. Code N° Cod. N° Referencia T7EDB	Part N° Teil Nr. Code N° Cod. N° Referencia T7EDBS	Qty Stück Qté Q.tà Cant.	
11	Port plate-rear <i>Piatto distributore post.</i>	Steuerplatte <i>Plato distribuidor trasero</i>	Plaque arrière	CN	034.66922		1	
12	Bush <i>Bussola</i>	Buchse <i>Cojinete de fricción</i>	Bague	CN	034.59412		1	
13	Sq. section seal <i>Guarnizione</i>	Dichtring <i>Junta seccion cuadrada</i>	Joint section carrée	CD	691.10232		1	
14	Port plate-pressure (Except cam rings 045 - 050) <i>Piatto distributore anter. (Eccetto anello camma 045-050)</i>	Steuerplatte (außer Hubringe 045-050) <i>Plato distribuidor-presión (Excepto los aros 045-050)</i>	Plaque pression (Excepté cames 045 - 050)	B	034.67479		1	
	Port plate-pressure C.C.W. (Only cam rings 045 - 050) <i>Piatto distributore anter. antioraria (Solo anello camma 045-050)</i>	Steuerplatte Linkslauf (nur Hubringe 045-050) <i>Plato distribuidor-presión giro I (Solo los aros 045-050)</i>	Plaque press. rot. G. (Seul. cames 045-050)	B	034.67111		1	
	Port plate-pressure C.W. (Only cam rings 045 - 050) <i>Piatto distributore anter. Oraria (Solo anello camma 045-050)</i>	Steuerplatte Rechtslauf (nur Hubringe 045-050) <i>Plato distribuidor-presión giro D (Solo los aros 045-050)</i>	Plaque press. rot. D. (Seul. cames 045-050)	B	034.67113		1	
	Sq. section seal <i>Guarnizione</i>	Dichtring <i>Junta seccion cuadrada</i>	Joint section carrée	BD	691.10244		1	
16	Back-up ring <i>Anello anti-estrusione</i>	Stützring <i>Anillo</i>	Bague anti-extrusion	BD	618.00011.3		1	
17	Cam ring 014 <i>Anello camma 014</i>	Hubring 014 <i>Aro volumetrico 014</i>	Came 014	B	034.67469		1	
	Cam ring 017 <i>Anello camma 017</i>	Hubring 017 <i>Aro volumetrico 017</i>	Came 017	B	034.67470		1	
	Cam ring 020 <i>Anello camma 020</i>	Hubring 020 <i>Aro volumetrico 020</i>	Came 020	B	034.67159		1	
	Cam ring 022 <i>Anello camma 022</i>	Hubring 022 <i>Aro volumetrico 022</i>	Came 022	B	034.67482		1	
	Cam ring 024 <i>Anello camma 024</i>	Hubring 024 <i>Aro volumetrico 024</i>	Came 024	B	034.67158		1	
	Cam ring 028 <i>Anello camma 028</i>	Hubring 028 <i>Aro volumetrico 028</i>	Came 028	B	034.67157		1	
	Cam ring 031 <i>Anello camma 031</i>	Hubring 031 <i>Aro volumetrico 031</i>	Came 031	B	034.67156		1	
	Cam ring 035 <i>Anello camma 035</i>	Hubring 035 <i>Aro volumetrico 035</i>	Came 035	B	034.67155		1	
	Cam ring 038 <i>Anello camma 038</i>	Hubring 038 <i>Aro volumetrico 038</i>	Came 038	B	034.67154		1	
	Cam ring 042 <i>Anello camma 042</i>	Hubring 042 <i>Aro volumetrico 042</i>	Came 042	B	034.67153		1	
	Cam ring 045 <i>Anello camma 045</i>	Hubring 045 <i>Aro volumetrico 045</i>	Came 045	B	034.59131		1	
	Cam ring 050 <i>Anello camma 050</i>	Hubring 050 <i>Aro volumetrico 050</i>	Came 050	B	034.66737		1	
	18	Vane (Except cam rings 045 - 050) <i>Paletta (Eccetto anello camma 045-050)</i>	Flügel (außer Hubringe 045-050) <i>Paleta (Excepto los aros 045-050)</i>	Palette (Excepté cames 045 - 050)	B	034.67453		12
		Vane (Only cam ring 045 - 050) <i>Paletta (Solo anello camma 045-050)</i>	Flügel (nur Hubringe 045-050) <i>Paleta (Solo los aros 045-050)</i>	Palette (Seul. cames 045-050)	B	034.53588		10
		Pin-vane holdout (Except cam rings 045 - 050) <i>Pistoncino di sostentamento (Eccetto anello camma 045-050)</i>	Stößel (außer Hubringe 045-050) <i>Espiga empuje paleta (Excepto los aros 045-050)</i>	Poussoir de palette (Excepté cames 045 - 050)	B	034.59098		12
	19	Pin-vane holdout (Only cam ring 045 - 050) <i>Pistoncino di sostentamento (Solo anello camma 045-050)</i>	Stößel (nur Hubringe 045-050) <i>Espiga empuje paleta (Solo los aros 045-050)</i>	Poussoir de palette (Seul. cames 045-050)	B	034.59130		10
Rotor ass'y (Except cam rings 045 - 050) <i>Insieme rotore (Eccetto anello camma 045-050)</i>		Rotor (außer Hubringe 045-050) <i>Conjunto rotor Excepto los aros 045-050)</i>	Rotor ass. (Excepté cames 045 - 050)	B	S24.73783		1	

Item Pos. Pos. Pos.	Description Descrizione	Benennung Descripcion	Description		Part N° Teil Nr. Code N° Cod. N° Referencia T7EDB	Part N° Teil Nr. Code N° Cod. N° Referencia T7EDBS	Qty Stück Qté Q.tà Cant.
20	Rotor ass'y (Only cam ring 045 - 050) <i>Insieme rotore (Solo anello camma 045-050)</i>	Rotor (nur Hubringe 045-050) <i>Conjunto rotor (Solo los aros 045-050)</i>	Rotor ass. (Seul. cames 045-050)	B	S24.10121		1
21	Port plate-rear (Except cam rings 045 - 050) <i>Piatto distributore post. (Eccetto anello camma 045-050)</i>	Steuerplatte (außer Hubringe 045-050) <i>Plato distribuidor trasero ((Excepto los aros 045-050)</i>	Plaque arrière (Excepté cames 045 - 050)	BK	034.67484		1
	Port plate-rear C.C.W. (Only cam ring 045 - 050) <i>Piatto distributore post. Antioraria (Solo anello camma 045-050)</i>	Steuerplatte Linkslauf (nur Hubringe 045-050) <i>Plato distribuidor trasero giro l (Solo los aros 045-050)</i>	Plaque arr. rotation g. (Seul. cames 045-050)	BL	034.67475		1
	Port plate-rear C.W. (Only cam ring 045 - 050) <i>Piatto distributore post. Oraria (Solo anello camma 045-050)</i>	Steuerplatte Rechtslauf (nur Hubringe 045-050) <i>Plato distribuidor trasero giro D (Solo los aros 045-050)</i>	Plaque arr. rotation d. (Seul. cames 045-050)	BM	034.67474		1
	Bush <i>Bussola</i>	Buchse <i>Cojinete de fricción</i>	Bague	BK LM	034.70868		1
23	Dowel pin <i>Spina</i>	Zentrierstift <i>Pasador</i>	Goupille	BK LM	323.82004		1
24	Dowel pin <i>Spina</i>	Zentrierstift <i>Pasador</i>	Goupille	AHJ	323.82014		1
25	Vane <i>Paletta</i>	Flügel <i>Paleta</i>	Palette	A	034.59162		12
26	Pin-vane holdout <i>Pistoncino di sostentamento</i>	Stößel <i>Espiga empuje paleta</i>	Poussoir de palette	A	034.59161		12
27	Round section ring <i>Anello elastico</i>	Sicherungsring <i>Anillo tórico</i>	Anneau	EFG	034.70866		1
28	Retaining ring <i>Anello elastico</i>	Sicherungsring <i>Anillo de retención</i>	Circlips		356.30315		1
29	Ball bearing <i>Cuscinetto a sfere</i>	Kugellager <i>Cojinete de bolas</i>	Roulement à billes	EFG	230.90018.3		1
30	Shaft seal (S1 - 0,7 bar) <i>Paraolio (S1 - 0,7 bar)</i>	Simmerring (S1 - 0,7 bar) <i>Reten eje (S1 - 0,7 bar)</i>	Joint d'arbre (S1 - 0,7 bar)	D	620.00022.3		1
	Shaft seal (S4 - S5 - 7 bar) <i>Paraolio (S4 - S5 - 7 bar)</i>	Simmerring (S4 - S5 - 7 bar) <i>Reten eje (S4 - S5 - 7 bar)</i>	Joint d'arbre (S4 - S5 - 7 bar)	D	620.00019.3		1
31a	Key (code 1) <i>Chiavetta (codice 1)</i>	Paßfeder (Typ 1) <i>Chaveta (codigo 1)</i>	Clavette (code 1)	E	034.66786		1
31b	Key (code 2) <i>Chiavetta (codice 2)</i>	Paßfeder (Typ 2) <i>Chaveta (codigo 2)</i>	Clavette (code 2)	F		034.66978	1
32a	Shaft (keyed) (code1) <i>Albero a chiavetta (codice 1)</i>	Welle für Paßfeder (Typ 1) <i>Eje chaveteado (codigo 1)</i>	Arbre à clavette (code 1)	E	034.66785		1
32b	Shaft (keyed) (code 2) (SAE D & E) <i>Albero a chiavetta (codice 2) (SAE D &amp; E)</i>	Welle für Paßfeder (Typ 2) (SAE D & E) <i>Eje chaveteado (codigo 2) (SAE D &amp; E)</i>	Arbre à clavette (code 2) (SAE D & E)	F		034.66977	1
32c	Shaft (splined) (code 3) (SAE D & E) <i>Albero a scanalato (codice 3) (SAE D &amp; E)</i>	Vielkeilwelle (Typ 3) (SAE D & E) <i>Eje estriado (codigo 3) (SAE D &amp; E)</i>	Arbre à cannelures (code 3) (SAE D & E)	G		034.66784	1
33	Mounting cap (metric) <i>Coperchio (metrica)</i>	Deckel (Metrisch) <i>Tapa de montaje 1" (metrico)</i>	Chapeau de montage (métrique)		034.66781	034.67314	1
	Mounting cap (UNC) <i>Coperchio (UNC)</i>	Deckel (UNC) <i>Tapa de montaje (UNC)</i>	Chapeau de montage (UNC)			034.66809	1
34	Sq. section seal <i>Guarnizione</i>	Dichtring <i>Junta seccion cuadrada</i>	Joint section carrée	AD	691.10237		1
35	Port plate-pressure C.C.W. <i>Piatto distributore anter.antioraria</i>	Steuerplatte Linkslauf <i>Plato distribuidor-presión giro l</i>	Plaque pression rotation gauche	A	034.67434		1
	Port plate-pressure C.W. <i>Piatto distributore anter. oraria</i>	Steuerplatte Rechtslauf <i>Plato distribuidor-presión giro D</i>	Plaque pression rotation droite	A	034.67408		1
36	Sq. section seal <i>Guarnizione</i>	Dichtring <i>Junta seccion cuadrada</i>	Joint section carrée	AD	691.10253		1

Item Pos. Réf. Pos. Pos.	Description Descrizione	Benennung Descripcion	Description		Part N° Teil Nr. Code N° Cod. N° Referencia T7EDB	Part N° Teil Nr. Code N° Cod. N° Referencia T7EDBS	Qty Stück Qté Q.tà Cant.	
37	Back-up ring <i>Anello anti-estrusione</i>	Stützring <i>Anillo</i>	Bague anti-extrusion	AD	618.00012.3		1	
38	Sq. section seal <i>Guarnizione</i>	Dichtring <i>Junta seccion cuadrada</i>	Joint section carrée	AD	671.10259		1	
39	Rotor ass'y <i>Insieme rotore</i>	Rotor <i>Conjunto rotor</i>	Rotor ass,	A	S24.10185		1	
40	Cam ring 042 <i>Anello camma 042</i>	Hubring 042 <i>Aro volumetrico 042</i>	Came 042	A	034.67503		1	
	Cam ring 045 <i>Anello camma 045</i>	Hubring 045 <i>Aro volumetrico 045</i>	Came 045	A	034.67504		1	
	Cam ring 050 <i>Anello camma 050</i>	Hubring 050 <i>Aro volumetrico 050</i>	Came 050	A	034.67505		1	
	Cam ring 052 <i>Anello camma 052</i>	Hubring 052 <i>Aro volumetrico 052</i>	Came 052	A	034.67506		1	
	Cam ring 054 <i>Anello camma 054</i>	Hubring 054 <i>Aro volumetrico 054</i>	Came 054	A	034.67619		1	
	Cam ring 057 <i>Anello camma 057</i>	Hubring 057 <i>Aro volumetrico 057</i>	Came 057	A	034.67507		1	
	Cam ring 062 <i>Anello camma 062</i>	Hubring 062 <i>Aro volumetrico 062</i>	Came 062	A	034.67508		1	
	Cam ring 066 <i>Anello camma 066</i>	Hubring 066 <i>Aro volumetrico 066</i>	Came 066	A	034.67509		1	
	Cam ring 072 <i>Anello camma 072</i>	Hubring 072 <i>Aro volumetrico 072</i>	Came 072	A	034.67447		1	
	Cam ring 085 <i>Anello camma 085</i>	Hubring 085 <i>Aro volumetrico 085</i>	Came 085	A	034.67455		1	
	41	Dowel pin <i>Spina</i>	Zentrierstift <i>Pasador</i>	Goupille	A	324.22016		2
	42	Port plate-rear C.C.W. <i>Piatto distributore post. Antioraria</i>	Steuerplatte Linkslauf <i>Plato distribuidor trasero giro I</i>	Plaque arr. rotation gauche	AH	034.67435		1
		Port plate-rear C.W. <i>Piatto distributore post. Oraria</i>	Steuerplatte Rechtslauf <i>Plato distribuidor trasero giro D</i>	Plaque arr. rotation droite	AJ	034.67407		1
	43	Screw <i>Vite</i>	Schraube <i>Tornille</i>	Vis	AHJ	310.10340		2
44	Dowel pin <i>Spina</i>	Zentrierstift <i>Pasador</i>	Goupille	B	324.21612		1	
45	Screw <i>Vite</i>	Schraube <i>Tornille</i>	Vis	B	317.10300.3		2	
46	Housing (standard) (metric) <i>Corpo (standard) (metrico)</i>	Gehäuse (Standard) (Metrisch) <i>Cuerpo (estándar) (metrica)</i>	Carter (standard) (métrique)		034.66782		1	
	Housing (standard) (UNC) <i>Corpo (standard) (UNC)</i>	Gehäuse (Standard) (UNC) <i>Cuerpo (estándar) (UNC)</i>	Carter (standard) (UNC)		034.66810	1		
47	Sq. section seal <i>Guarnizione</i>	Dichtring <i>Junta seccion cuadrada</i>	Joint section carrée	BD	671.10159		1	
48	Port block UNC <i>Corpo bocche UNC</i>	Anschlußblock UNC <i>Bloque distribuidor UNC</i>	Palier UNC		034.66812		1	
	Port block metric <i>Corpo bocche metrica</i>	Anschlußblock Metrich <i>Bloque distribuidor metrico</i>	Palier métrique		034.66783		1	
49	Screw <i>Vite</i>	Schraube <i>Tornille</i>	Vis		361.14464.3		4	

Item Pos. Pos. Pos.	Description Descrizione	Benennung Descripcion	Description	Part N° Teil Nr. Code N° Cod. N° Referencia T7EDB	Part N° Teil Nr. Code N° Cod. N° Referencia T7EDBS	Qty Stück Qté Q.tà Cant.
50	Dowel pin <i>Spina</i>	Zentrierstift <i>Pasador</i>	Goupille	CN	323.82010	1
51	Dowel pin <i>Spina</i>	Zentrierstift <i>Pasador</i>	Goupille	C	324.21208	2
52	Screw <i>Vite</i>	Schraube <i>Tornille</i>	Vis		361.14324.3	4
53	Screw <i>Vite</i>	Schraube <i>Tornille</i>	Vis	C	317.06266	2
54	Screw <i>Vite</i>	Schraube <i>Tornille</i>	Vis		361.11264.3	7
	<b>REPAIR KIT</b> <b>KIT DI RICAMBIO</b>	<b>AUSTAUSCH-BAUGRUPPEN</b> <b>CUNJUNTO REPARACION</b>	<b>POCHETTES RECHANGES</b>			
A	Cart. and plate ass'y 042 C.W. (P1) <i>Ins. cart. 042 oraria (P1)</i>	Pumpeneinheit 042 Rechtslauf (P1) <i>Conjunto cart. y platos 042 giro d. (P1)</i>	Cart. et plaque ass. 042 rot. d. (P1)		S24.77675	1
A	Cart. and plate ass'y 042 C.C.W. (P1) <i>Ins. cart. 042 antioraria (P1)</i>	Pumpeneinheit 042 Linkslauf (P1) <i>Conjunto cart. y platos 042 giro i. (P1)</i>	Cart. et plaque ass. 042 rot. g. (P1)		S24.77676	1
A	Cart. and plate ass'y 045 C.W. (P1) <i>Ins. cart. 045 oraria (P1)</i>	Pumpeneinheit 045 Rechtslauf (P1) <i>Conjunto cart. y platos 045 giro d. (P1)</i>	Cart. et plaque ass. 045 rot. d. (P1)		S24.77677	1
A	Cart. and plate ass'y 045 C.C.W. (P1) <i>Ins. cart. 045 antioraria (P1)</i>	Pumpeneinheit 045 Linkslauf (P1) <i>Conjunto cart. y platos 045 giro i. (P1)</i>	Cart. et plaque ass. 045 rot. g. (P1)		S24.77678	1
A	Cart. and plate ass'y 050 C.W. (P1) <i>Ins. cart. 050 oraria (P1)</i>	Pumpeneinheit 050 Rechtslauf (P1) <i>Conjunto cart. y platos 050 giro d. (P1)</i>	Cart. et plaque ass. 050 rot. d. (P1)		S24.77679	1
A	Cart. and plate ass'y 050 C.C.W. (P1) <i>Ins. cart. 050 antioraria (P1)</i>	Pumpeneinheit 050 Linkslauf (P1) <i>Conjunto cart. y platos 050 giro i. (P1)</i>	Cart. et plaque ass. 050 rot. g. (P1)		S24.77680	1
A	Cart. and plate ass'y 052 C.W. (P1) <i>Ins. cart. 052 oraria (P1)</i>	Pumpeneinheit 052 Rechtslauf (P1) <i>Conjunto cart. y platos 052 giro d. (P1)</i>	Cart. et plaque ass. 052 rot. d. (P1)		S24.77681	1
A	Cart. and plate ass'y 052 C.C.W. (P1) <i>Ins. cart. 052 antioraria (P1)</i>	Pumpeneinheit 052 Linkslauf (P1) <i>Conjunto cart. y platos 052 giro i. (P1)</i>	Cart. et plaque ass. 052 rot. g. (P1)		S24.77682	1
A	Cart. and plate ass'y 054 C.W. (P1) <i>Ins. cart. 054 oraria (P1)</i>	Pumpeneinheit 054 Rechtslauf (P1) <i>Conjunto cart. y platos 054 giro d. (P1)</i>	Cart. et plaque ass. 054 rot. d. (P1)		S24.77683	1
A	Cart. and plate ass'y 054 C.C.W. (P1) <i>Ins. cart. 054 antioraria (P1)</i>	Pumpeneinheit 054 Linkslauf (P1) <i>Conjunto cart. y platos 054 giro i. (P1)</i>	Cart. et plaque ass. 054 rot. g. (P1)		S24.77684	1
A	Cart. and plate ass'y 057 C.W. (P1) <i>Ins. cart. 057 oraria (P1)</i>	Pumpeneinheit 057 Rechtslauf (P1) <i>Conjunto cart. y platos 057 giro d. (P1)</i>	Cart. et plaque ass. 057 rot. d. (P1)		S24.77685	1
A	Cart. and plate ass'y 057 C.C.W. (P1) <i>Ins. cart. 057 antioraria (P1)</i>	Pumpeneinheit 057 Linkslauf (P1) <i>Conjunto cart. y platos 057 giro i. (P1)</i>	Cart. et plaque ass. 057 rot. g. (P1)		S24.77686	1
A	Cart. and plate ass'y 062 C.W. (P1) <i>Ins. cart. 062 oraria (P1)</i>	Pumpeneinheit 062 Rechtslauf (P1) <i>Conjunto cart. y platos 062 giro d. (P1)</i>	Cart. et plaque ass. 062 rot. d. (P1)		S24.77687	1
A	Cart. and plate ass'y 062 C.C.W. (P1) <i>Ins. cart. 062 antioraria (P1)</i>	Pumpeneinheit 062 Linkslauf (P1) <i>Conjunto cart. y platos 062 giro i. (P1)</i>	Cart. et plaque ass. 062 rot. g. (P1)		S24.77688	1
A	Cart. and plate ass'y 066 C.W. (P1) <i>Ins. cart. 066 oraria (P1)</i>	Pumpeneinheit 066 Rechtslauf (P1) <i>Conjunto cart. y platos 066 giro d. (P1)</i>	Cart. et plaque ass. 066 rot. d. (P1)		S24.77689	1
A	Cart. and plate ass'y 066 C.C.W. (P1) <i>Ins. cart. 066 antioraria (P1)</i>	Pumpeneinheit 066 Linkslauf (P1) <i>Conjunto cart. y platos 066 giro i. (P1)</i>	Cart. et plaque ass. 066 rot. g. (P1)		S24.77690	1
A	Cart. and plate ass'y 072 C.W. (P1) <i>Ins. cart. 072 oraria (P1)</i>	Pumpeneinheit 072 Rechtslauf (P1) <i>Conjunto cart. y platos 072 giro d. (P1)</i>	Cart. et plaque ass. 072 rot. d. (P1)		S24.77691	1
A	Cart. and plate ass'y 072 C.C.W. (P1) <i>Ins. cart. 072 antioraria (P1)</i>	Pumpeneinheit 072 Linkslauf (P1) <i>Conjunto cart. y platos 072 giro i. (P1)</i>	Cart. et plaque ass. 072 rot. g. (P1)		S24.77692	1

Item Pos. Réf. Pos. Pos.	Description <i>Descrizione</i>	Benennung <i>Descripcion</i>	Description	Part N° Teil Nr. Code N° Cod. N° Referencia T7EDB	Part N° Teil Nr. Code N° Cod. N° Referencia T7EDBS	Qty Stück Qté Q.tà Cant.
A	Cart. and plate ass'y 085 C.W. (P1) <i>Ins. cart. 085 oraria (P1)</i>	Pumpeneinheit 085 Rechtslauf (P1) <i>Conjunto cart. y platos 085 giro d. (P1)</i>	Cart. et plaque ass. 085 rot. d. (P1)		S24.77693	1
A	Cart. and plate ass'y 085 C.C.W. (P1) <i>Ins. cart. 085 antioraria (P1)</i>	Pumpeneinheit 085 Linkslauf (P1) <i>Conjunto cart. y platos 085 giro i. (P1)</i>	Cart. et plaque ass. 085 rot. g. (P1)		S24.77694	1
B	Cart. and plate ass'y B14 C.W. (P2) <i>Ins. cart. B14 oraria (P2)</i>	Pumpeneinheit B14 Rechtslauf (P2) <i>Conjunto cart. y platos B14 giro d. (P2)</i>	Cart. et plaque ass. B14 rot. d. (P2)		S24.90570	1
B	Cart. and plate ass'y B14 C.C.W. (P2) <i>Ins. cart. B14 antioraria (P2)</i>	Pumpeneinheit B14 Linkslauf (P2) <i>Conjunto cart. y platos B14 giro i. (P2)</i>	Cart. et plaque ass. B14 rot. g. (P2)		S24.90571	1
B	Cart. and plate ass'y B17 C.W. (P2) <i>Ins. cart. B17 oraria (P2)</i>	Pumpeneinheit B17 Rechtslauf (P2) <i>Conjunto cart. y platos B17 giro d. (P2)</i>	Cart. et plaque ass. B17 rot. d. (P2)		S24.90572	1
B	Cart. and plate ass'y B17 C.C.W. (P2) <i>Ins. cart. B17 antioraria (P2)</i>	Pumpeneinheit B17 Linkslauf (P2) <i>Conjunto cart. y platos B17 giro i. (P2)</i>	Cart. et plaque ass. B17 rot. g. (P2)		S24.90573	1
B	Cart. and plate ass'y B20 C.W. (P2) <i>Ins. cart. B20 oraria (P2)</i>	Pumpeneinheit B20 Rechtslauf (P2) <i>Conjunto cart. y platos B20 giro d. (P2)</i>	Cart. et plaque ass. B20 rot. d. (P2)		S24.90574	1
B	Cart. and plate ass'y B20 C.C.W. (P2) <i>Ins. cart. B20 antioraria (P2)</i>	Pumpeneinheit B20 Linkslauf (P2) <i>Conjunto cart. y platos B20 giro i. (P2)</i>	Cart. et plaque ass. B20 rot. g. (P2)		S24.90575	1
B	Cart. and plate ass'y B22 C.W. (P2) <i>Ins. cart. B22 oraria (P2)</i>	Pumpeneinheit B22 Rechtslauf (P2) <i>Conjunto cart. y platos B22 giro d. (P2)</i>	Cart. et plaque ass. B22 rot. d. (P2)		S24.90576	1
B	Cart. and plate ass'y B22 C.C.W. (P2) <i>Ins. cart. B22 antioraria (P2)</i>	Pumpeneinheit B22 Linkslauf (P2) <i>Conjunto cart. y platos B22 giro i. (P2)</i>	Cart. et plaque ass. B22 rot. g. (P2)		S24.90577	1
B	Cart. and plate ass'y B24 C.W. (P2) <i>Ins. cart. B24 oraria (P2)</i>	Pumpeneinheit B24 Rechtslauf (P2) <i>Conjunto cart. y platos B24 giro d. (P2)</i>	Cart. et plaque ass. B24 rot. d. (P2)		S24.90578	1
B	Cart. and plate ass'y B24 C.C.W. (P2) <i>Ins. cart. B24 antioraria (P2)</i>	Pumpeneinheit B24 Linkslauf (P2) <i>Conjunto cart. y platos B24 giro i. (P2)</i>	Cart. et plaque ass. B24 rot. g. (P2)		S24.90579	1
B	Cart. and plate ass'y B28 C.W. (P2) <i>Ins. cart. B28 oraria (P2)</i>	Pumpeneinheit B28 Rechtslauf (P2) <i>Conjunto cart. y platos B28 giro d. (P2)</i>	Cart. et plaque ass. B28 rot. d. (P2)		S24.90580	1
B	Cart. and plate ass'y B28 C.C.W. (P2) <i>Ins. cart. B28 antioraria (P2)</i>	Pumpeneinheit B28 Linkslauf (P2) <i>Conjunto cart. y platos B28 giro i. (P2)</i>	Cart. et plaque ass. B28 rot. g. (P2)		S24.90581	1
B	Cart. and plate ass'y B31 C.W. (P2) <i>Ins. cart. B31 oraria (P2)</i>	Pumpeneinheit B31 Rechtslauf (P2) <i>Conjunto cart. y platos B31 giro d. (P2)</i>	Cart. et plaque ass. B31 rot. d. (P2)		S24.90582	1
B	Cart. and plate ass'y B31 C.C.W. (P2) <i>Ins. cart. B31 antioraria (P2)</i>	Pumpeneinheit B31 Linkslauf (P2) <i>Conjunto cart. y platos B31 giro i. (P2)</i>	Cart. et plaque ass. B31 rot. g. (P2)		S24.90583	1
B	Cart. and plate ass'y B35 C.W. (P2) <i>Ins. cart. B35 oraria (P2)</i>	Pumpeneinheit B35 Rechtslauf (P2) <i>Conjunto cart. y platos B35 giro d. (P2)</i>	Cart. et plaque ass. B35 rot. d. (P2)		S24.90584	1
B	Cart. and plate ass'y B35 C.C.W. (P2) <i>Ins. cart. B35 antioraria (P2)</i>	Pumpeneinheit B35 Linkslauf (P2) <i>Conjunto cart. y platos B35 giro i. (P2)</i>	Cart. et plaque ass. B35 rot. g. (P2)		S24.90585	1
B	Cart. and plate ass'y B38 C.W. (P2) <i>Ins. cart. B38 oraria (P2)</i>	Pumpeneinheit B38 Rechtslauf (P2) <i>Conjunto cart. y platos B38 giro d. (P2)</i>	Cart. et plaque ass. B38 rot. d. (P2)		S24.90586	1
B	Cart. and plate ass'y B38 C.C.W. (P2) <i>Ins. cart. B38 antioraria (P2)</i>	Pumpeneinheit B38 Linkslauf (P2) <i>Conjunto cart. y platos B38 giro i. (P2)</i>	Cart. et plaque ass. B38 rot. g. (P2)		S24.90587	1
B	Cart. and plate ass'y B42 C.W. (P2) <i>Ins. cart. B42 oraria (P2)</i>	Pumpeneinheit B42 Rechtslauf (P2) <i>Conjunto cart. y platos B42 giro d. (P2)</i>	Cart. et plaque ass. B42 rot. d. (P2)		S24.90588	1
B	Cart. and plate ass'y B42 C.C.W. (P2) <i>Ins. cart. B42 antioraria (P2)</i>	Pumpeneinheit B42 Linkslauf (P2) <i>Conjunto cart. y platos B42 giro i. (P2)</i>	Cart. et plaque ass. B42 rot. g. (P2)		S24.90589	1
B	Cart. and plate ass'y 045 C.W. (P2) <i>Ins. cart. 045 oraria (P2)</i>	Pumpeneinheit 045 Rechtslauf (P2) <i>Conjunto cart. y platos 045 giro d. (P2)</i>	Cart. et plaque ass. 045 rot. d. (P2)		S24.10871	1
B	Cart. and plate ass'y 045 C.C.W. (P2) <i>Ins. cart. 045 antioraria (P2)</i>	Pumpeneinheit 045 Linkslauf (P2) <i>Conjunto cart. y platos 045 giro i. (P2)</i>	Cart. et plaque ass. 045 rot. g. (P2)		S24.10872	1
B	Cart. and plate ass'y 050 C.W. (P2) <i>Ins. cart. 050 oraria (P2)</i>	Pumpeneinheit 050 Rechtslauf (P2) <i>Conjunto cart. y platos 050 giro d. (P2)</i>	Cart. et plaque ass. 050 rot. d. (P2)		S24.40387	1



Item Pos. Réf. Pos. Pos.	Description <i>Descrizione</i>	Benennung <i>Descripcion</i>	Description	Part N° Teil Nr. Code N° Cod. N° Referencia T7EDB	Part N° Teil Nr. Code N° Cod. N° Referencia T7EDBS	Qty Stück Qté Q.tà Cant.
B	Cart. and plate ass'y 050 C.C.W. (P2) Ins. cart. 050 antioraria (P2)	Pumpeneinheit 050 Linkslauf (P2) Conjunto cart. y platos 050 giro i. (P2)	Cart. et plaque ass. 050 rot. g. (P1)		S24.40388	1
C	Cart. and plate ass'y B02 C.W. (P3) Ins. cart. B02 oraria (P3)	Pumpeneinheit B02 Rechtslauf (P3) Conjunto cart. y platos B02 giro d. (P3)	Cart. et plaque ass. B02 rot. d. (P3)		S24.50610	1
C	Cart. and plate ass'y B02 C.C.W. (P3) Ins. cart. B02 antioraria (P3)	Pumpeneinheit B02 Linkslauf (P3) Conjunto cart. y platos B02 giro i. (P3)	Cart. et plaque ass. B02 rot. g. (P3)		S24.50611	1
C	Cart. and plate ass'y B03 C.W. (P3) Ins. cart. B03 oraria (P3)	Pumpeneinheit B03 Rechtslauf (P3) Conjunto cart. y platos B03 giro d. (P3)	Cart. et plaque ass. B03 rot. d. (P3)		S24.50612	1
C	Cart. and plate ass'y B03 C.C.W. (P3) Ins. cart. B03 antioraria (P3)	Pumpeneinheit B03 Linkslauf (P3) Conjunto cart. y platos B03 giro i. (P3)	Cart. et plaque ass. B03 rot. g. (P3)		S24.50613	1
C	Cart. and plate ass'y B04 C.W. (P3) Ins. cart. B04 oraria (P3)	Pumpeneinheit B04 Rechtslauf (P3) Conjunto cart. y platos B04 giro d. (P3)	Cart. et plaque ass. B04 rot. d. (P3)		S24.50614	1
C	Cart. and plate ass'y B04 C.C.W. (P3) Ins. cart. B04 antioraria (P3)	Pumpeneinheit B04 Linkslauf (P3) Conjunto cart. y platos B04 giro i. (P3)	Cart. et plaque ass. B04 rot. g. (P3)		S24.50615	1
C	Cart. and plate ass'y B05 C.W. (P3) Ins. cart. B05 oraria (P3)	Pumpeneinheit B05 Rechtslauf (P3) Conjunto cart. y platos B05 giro d. (P3)	Cart. et plaque ass. B05 rot. d. (P3)		S24.50616	1
C	Cart. and plate ass'y B05 C.C.W. (P3) Ins. cart. B05 antioraria (P3)	Pumpeneinheit B05 Linkslauf (P3) Conjunto cart. y platos B05 giro i. (P3)	Cart. et plaque ass. B05 rot. g. (P3)		S24.50617	1
C	Cart. and plate ass'y B06 C.W. (P3) Ins. cart. B06 oraria (P3)	Pumpeneinheit B06 Rechtslauf (P3) Conjunto cart. y platos B06 giro d. (P3)	Cart. et plaque ass. B06 rot. d. (P3)		S24.50618	1
C	Cart. and plate ass'y B06 C.C.W. (P3) Ins. cart. B06 antioraria (P3)	Pumpeneinheit B06 Linkslauf (P3) Conjunto cart. y platos B06 giro i. (P3)	Cart. et plaque ass. B06 rot. g. (P3)		S24.50619	1
C	Cart. and plate ass'y B07 C.W. (P3) Ins. cart. B07 oraria (P3)	Pumpeneinheit B07 Rechtslauf (P3) Conjunto cart. y platos B07 giro d. (P3)	Cart. et plaque ass. B07 rot. d. (P3)		S24.59907	1
C	Cart. and plate ass'y B07 C.C.W. (P3) Ins. cart. B07 antioraria (P3)	Pumpeneinheit B07 Linkslauf (P3) Conjunto cart. y platos B07 giro i. (P3)	Cart. et plaque ass. B07 rot. g. (P3)		S24.59908	1
C	Cart. and plate ass'y B08 C.W. (P3) Ins. cart. B08 oraria (P3)	Pumpeneinheit B08 Rechtslauf (P3) Conjunto cart. y platos B08 giro d. (P3)	Cart. et plaque ass. B08 rot. d. (P3)		S24.50620	1
C	Cart. and plate ass'y B08 C.C.W. (P3) Ins. cart. B08 antioraria (P3)	Pumpeneinheit B08 Linkslauf (P3) Conjunto cart. y platos B08 giro i. (P3)	Cart. et plaque ass. B08 rot. g. (P3)		S24.50621	1
C	Cart. and plate ass'y B09 C.W. (P3) Ins. cart. B09 oraria (P3)	Pumpeneinheit B09 Rechtslauf (P3) Conjunto cart. y platos B09 giro d. (P3)	Cart. et plaque ass. B09 rot. d. (P3)		S24.72910	1
C	Cart. and plate ass'y B09 C.C.W. (P3) Ins. cart. B09 antioraria (P3)	Pumpeneinheit B09 Linkslauf (P3) Conjunto cart. y platos B09 giro i. (P3)	Cart. et plaque ass. B09 rot. g. (P3)		S24.72697	1
C	Cart. and plate ass'y B10 C.W. (P3) Ins. cart. B10 oraria (P3)	Pumpeneinheit B10 Rechtslauf (P3) Conjunto cart. y platos B10 giro d. (P3)	Cart. et plaque ass. B10 rot. d. (P3)		S24.50622	1
C	Cart. and plate ass'y B10 C.C.W. (P3) Ins. cart. B10 antioraria (P3)	Pumpeneinheit B10 Linkslauf (P3) Conjunto cart. y platos B10 giro i. (P3)	Cart. et plaque ass. B10 rot. g. (P3)		S24.50623	1
C	Cart. and plate ass'y B11 C.W. (P3) Ins. cart. B11 oraria (P3)	Pumpeneinheit B11 Rechtslauf (P3) Conjunto cart. y platos B11 giro d. (P3)	Cart. et plaque ass. B11 rot. d. (P3)		S24.77173	1
C	Cart. and plate ass'y B11 C.C.W. (P3) Ins. cart. B11 antioraria (P3)	Pumpeneinheit B11 Linkslauf (P3) Conjunto cart. y platos B11 giro i. (P3)	Cart. et plaque ass. B11 rot. g. (P3)		S24.76880	1
C	Cart. and plate ass'y B12 C.W. (P3) Ins. cart. B12 oraria (P3)	Pumpeneinheit B12 Rechtslauf (P3) Conjunto cart. y platos B12 giro d. (P3)	Cart. et plaque ass. B12 rot. d. (P3)		S24.59009	1
C	Cart. and plate ass'y B12 C.C.W. (P3) Ins. cart. B12 antioraria (P3)	Pumpeneinheit B12 Linkslauf (P3) Conjunto cart. y platos B12 giro i. (P3)	Cart. et plaque ass. B12 rot. g. (P3)		S24.59010	1
C	Cart. and plate ass'y B14 C.W. (P3) Ins. cart. B14 oraria (P3)	Pumpeneinheit B14 Rechtslauf (P3) Conjunto cart. y platos B14 giro d. (P3)	Cart. et plaque ass. B14 rot. d. (P3)		S24.77174	1
C	Cart. and plate ass'y B14 C.C.W. (P3) Ins. cart. B14 antioraria (P3)	Pumpeneinheit B14 Linkslauf (P3) Conjunto cart. y platos B14 giro i. (P3)	Cart. et plaque ass. B14 rot. g. (P3)		S24.77176	1

Item Pos. Réf. Pos. Pos.	Description <i>Descrizione</i>	Benennung <i>Descripcion</i>	Description	Part N° Teil Nr. Code N° Cod. N° Referencia T7EDB	Part N° Teil Nr. Code N° Cod. N° Referencia T7EDBS	Qty Stück Qté Q.tà Cant.
C	Cart. and plate ass'y B15 C.W. (P3) <i>Ins. cart. B15 oraria (P3)</i>	Pumpeneinheit B15 Rechtslauf (P3) <i>Conjunto cart. y platos B15 giro d. (P3)</i>	Cart. et plaque ass. B15 rot. d. (P3)	S24.59011		1
C	Cart. and plate ass'y B15 C.C.W. (P3) <i>Ins. cart. B15 antioraria (P3)</i>	Pumpeneinheit B15 Linkslauf (P3) <i>Conjunto cart. y platos B15 giro i. (P3)</i>	Cart. et plaque ass. B15 rot. g. (P3)	S24.59012		1
D	Seal kit (S1 - 0,7 bar) <i>Serie guarnizioni (S1 - 0,7 bar)</i>	Dichtringsatz (S1 - 0,7 bar) <i>Juego de juntas (S1 - 0,7 bar)</i>	Pochette de joint (S1 - 0,7 bar)	S24.44823		1
D	Seal kit (S5 - 7 bar) <i>Serie guarnizioni (S5 - 7 bar)</i>	Dichtringsatz (S5 - 7 bar) <i>Juego de juntas (S5 - 7 bar)</i>	Pochette de joint (S5 - 7 bar)	S24.44823.5		1
E	Shaft and bearing ass'y (code 1) <i>Ins. albero (codice 1)</i>	Baugruppe (Welle u. Lager) (Typ 1) <i>Conjunto eje cojinete (codigo 1)</i>	Arbre et roulement ass. (code 1)	S24.44516		1
F	Shaft and bearing ass'y (code 2) <i>Ins. albero (codice 2)</i>	Baugruppe (Welle u. Lager) (Typ 2) <i>Conjunto eje cojinete (codigo 2)</i>	Arbre et roulement ass. (code 2)		S24.51348	1
G	Shaft and bearing ass'y (code 3) <i>Ins. albero (codice 3)</i>	Baugruppe (Welle u. Lager) (Typ 3) <i>Conjunto eje cojinete (codigo 3)</i>	Arbre et roulement ass. (code 3)		S24.44517	1
H	Port plate rear ass'y C.C.W. (P1) <i>Ins. piatto distributore post. antioraria (P1)</i>	Steuerplatte Linkslauf (P1) <i>Conj. plato dist. trasero giro I (P1)</i>	Plaque arrière ass. rot. gauche (P1)	S24.76213		1
J	Port plate rear ass'y C.W. (P1) <i>Ins. piatto distributore post. oraria (P1)</i>	Steuerplatte Rechtslauf (P1) <i>Conj. plato dist. trasero giro D (P1)</i>	Plaque arrière ass. rot. droite (P1)	S24.73820		1
K	Port plate rear and bush ass'y (P2) (Except cam rings 045-050) <i>Ins. piatto dist. post. (P2)</i> <i>(Eccetto anello camma 045-050)</i>	Steuerplatte mit buchse (P2) (außer Hubringe 045-050) <i>Conj. plato dist. tras. con coj. Fricción (P2)</i> <i>(Excepto los aros 045-050)</i>	Plaque arr. et bague ass. (P2) (Excepté comes 045-050)	S24.90562		1
L	Port plate rear ass'y C.C.W. (P2) (Only cam ring 045 - 050) <i>Ins. piatto dist. post. Antioraria (P2)</i> <i>(Solo anello camma 045-050)</i>	Steuerplatte Linkslauf (P2) (nur Hubringe 045-050) <i>Conj. plato dist. trasero giro I (P2)</i> <i>(Solo los aros 045-050)</i>	Plaque arrière ass. rot. gauche (P2) (Seulement comes 045-050)	S24.76149		1
M	Port plate rear ass'y C.W. (P2) (Only cam ring 045 - 050) <i>Ins. piatto dist. post. Oraria (P2)</i> <i>(Solo anello camma 045-050)</i>	Steuerplatte Rechtslauf (P2) (nur Hubringe 045-050) <i>Conj. plato dist. trasero giro D (P2)</i> <i>(Solo los aros 045-050)</i>	Plaque arrière ass. rot. Droite (P2) (Seulement comes 045-050)	S24.76148		1
N	Port plate rear ass'y (P3) <i>Ins. piatto distributore post. (P3)</i>	Steuerplatte (P3) <i>Conj. plato dist. Trasero (P3)</i>	Plaque arrière ass. (P3)	S24.50642		1

## Model Code

## Typenschlüssel

## Désignation - type

### Model number :

**T7EDB series** - ISO 4 bolts 3019-2  
250-B4-HW  
**T7EDBS series** - SAE E - 4bolts  
Mounting flange J744

One letter can be added to specify special parts in series

### Cam ring for P1

(Volumetric displacement) (ml/rev.)  
042 = 132,3  
045 = 142,4  
050 = 158,5  
052 = 164,8

### Cam ring for P2

(Volumetric displacement) (ml/rev.)  
B14 = 44,0  
B17 = 55,0  
B20 = 66,0  
B22 = 70,3

### Cam ring for P3

(Volumetric displacement) (ml/rev.)  
B02 = 5,8  
B03 = 9,8  
B04 = 12,8  
B05 = 15,9  
B06 = 19,8

### Type of shaft T7EDB

1 = keyed (G45N-ISO 3019-2)

### Type of shaft T7EDBS

2 = keyed (SAE D & E)  
3 = splined 8/16 (SAE D & E)

### Direction of rotation

R = Clockwise L = Counter-clockwise

### Porting combination

00 = standard

### Design letter

### Seal class

1 = S1 - BUNA N  
4 = S4 - EPDM  
5 = S5 - VITON

### Mounting w/connection variables

P1 = 1"1/2 - P2 = 1"1/4 - S = 4"		
	UNC	Metric
T7EDB - P3 = 1"		M0
T7EDB - P3 = 3/4"		M1
T7EDBS - P3 = 1"	00	M0
T7EDBS - P3 = 3/4"	01	M1

### Modifications

### Typenbezeichnung :

**Baureihe T7EDB** - ISO 4-Loch 3019-2  
250-B4-HW  
**Baureihe T7EDBS** - SAE E - 4-Loch  
Montageflansch, J744

### Optionen

### Hubring P1

(Geometrisches Fördervolumen) (cm<sup>3</sup>/U)  
054 = 171,0  
057 = 183,3  
062 = 196,7

### Hubring P2

(Geometrisches Fördervolumen) (cm<sup>3</sup>/U)  
B24 = 81,1  
B28 = 90,0  
B31 = 99,2  
B35 = 113,4

### Hubring P3

(Geometrisches Fördervolumen) (cm<sup>3</sup>/U)  
B07 = 22,5  
B08 = 24,9  
B09 = 28,0  
B10 = 31,8

### Art der Welle T7EDB

1 = Paßfedervelle (G45N-ISO 3019-2)

### Art der Welle T7EDBS

2 = Paßfedervelle (SAE D & E)  
3 = Vielkeilwelle (SAE D & E)

### Drehrichtung

R = Rechtslauf L = Linkslauf

### Lage der Anschlüsse

0 = standard

### Ausführungsbuchstabe

### Dichtungsklasse

1 = S1 - BUNA N  
4 = S4 - EPDM  
5 = S5 - VITON

### Gehäuse-Anschlußgröße

P1 = 1"1/2 - P2 = 1"1/4 - S = 4"		
	UNC	Metrisches
T7EDB - P3 = 1"		M0
T7EDB - P3 = 3/4"		M1
T7EDBS - P3 = 1"	00	M0
T7EDBS - P3 = 3/4"	01	M1

### Modifikationen

### Numéro du modèle : T7EDB or T7EDBS . - 062 - B35 - B10 - 1 R 00 - A 1 - 01 - ..

**Série T7EDB** - ISO 4 trous 3019-2  
250-B4-HW  
Série T7EDBS - SAE E - 4 trous  
Bride de montage J744

Une lettre peut être ajoutée pour spécifier les pièces spéciales dans la série.

### Came pour P1

(Cylindrée théorique) (cm<sup>3</sup>/tr)  
066 = 213,3  
072 = 227,1  
085 = 268,7

### Came pour P2

(Cylindrée théorique) (cm<sup>3</sup>/tr)  
B38 = 120,6  
B42 = 137,5  
045 = 145,7  
050 = 158,0

### Came pour P3

(Cylindrée théorique) (cm<sup>3</sup>/tr)  
B11 = 35,0  
B12 = 41,0  
B14 = 45,0  
B15 = 50,0

### Type d'arbre T7EDB

1 = à clavette (G45N-ISO 3019-2)

### Type d'arbre T7EDBS

2 = à clavette (SAE D & E)  
3 = à cannelures (SAE D & E)

### Sens de rotation

R = à droite L = à gauche

### Combinaison des orifices

00 = standard

### Conception

### Classe de joint

1 = S1 - BUNA N  
4 = S4 - EPDM  
5 = S5 - VITON

### Option sur orifices

P1 = 1"1/2 - P2 = 1"1/4 - S = 4"		
	UNC	Métrique
T7EDB - P3 = 1"		M0
T7EDB - P3 = 3/4"		M1
T7EDBS - P3 = 1"	00	M0
T7EDBS - P3 = 3/4"	01	M1

### Modifications

## Designazione

## Clave de designación

### Sigla :

**Serie T7EDB** - ISO 4 fori 3019-2  
250-B4-HW  
**Serie T7EDBS** - SAE E - 4 fori  
Flangia di montaggio J744

### Referencia modelo :

**Serie T7EDB** - ISO 4 taladros 3019-2  
250-B4-HW  
**Serie T7EDBS** - SAE E - 4 taladros  
Brida de montaje J744

**T7EDB or T7EDBS** - **062** - **B35** - **B10** - **1 R 00** - **A 1** - **01** - ..

Una lettera può essere aggiunta per specificare parti speciali nella serie

Una letra puede ser añadide pasa especificar piezas especiales en la serie

### Tipo di cartuccia P1

(Cylindrata) (ml/giro)

042 = 132,3                      054 = 171,0  
045 = 142,4                      057 = 183,3  
050 = 158,5                      062 = 196,7  
052 = 164,8

### Aro volumetrico para P1

(Cilindrada) (ml/rev)

066 = 213,3  
072 = 227,1  
085 = 268,7

### Tipo di cartuccia P2

(Cylindrata) (ml/giro)

B14 = 44,0                      B24 = 81,1  
B17 = 55,0                      B28 = 90,0  
B20 = 66,0                      B31 = 99,2  
B22 = 70,3                      B35 = 113,4

### Aro volumetrico para P2

(Cilindrada) (ml/rev)

B38 = 120,6  
B42 = 137,5  
045 = 145,7  
050 = 158,0

### Tipo di cartuccia P3

(Cylindrata) (ml/giro)

B02 = 5,8                      B07 = 22,5  
B03 = 9,8                      B08 = 24,9  
B04 = 12,8                      B09 = 28,0  
B05 = 15,9                      B10 = 31,8  
B06 = 19,8

### Aro volumetrico para P3

(Cilindrada) (ml/rev)

B11 = 35,0  
B12 = 41,0  
B14 = 45,0  
B15 = 50,0

### Tipo di albero T7EDB

1 = a chiavetta (G45N-ISO 3019-2)

### Tipo de eje T7EDB

1 = chaveteado (G45N-ISO 3019-2)

### Tipo di albero T7EDBS

2 = a chiavetta (SAE D & E)  
3 = scanalato (SAE D & E)

### Tipo de eje T7EDBS

2 = chaveteado (SAE D & E)  
3 = scanalato (SAE D & E)

### Senso di rotazione

R = Orario                      L = Antiorario

### Sentido de giro

R = Derecha                      L = Izquierda

### Orientamento delle bocche

00 = standard

### Posición de bocas

00 = estándar

### Disegno

### Letra de diseño

### Tipo di guarnizioni

1 = S1 - BUNA N  
4 = S4 - EPDM  
5 = S5 - VITON

### Clase de juntas

1 = S1 - BUNA N  
4 = S4 - EPDM  
5 = S5 - VITON

### Dimensioni delle bocche

P1 = 1"1/2 - P2 = 1"1/4 - S = 4"		
	UNC	Metrica
T7EDB - P3 = 1"		M0
T7EDB - P3 = 3/4"		M1
T7EDBS - P3 = 1"	00	M0
T7EDBS - P3 = 3/4"	01	M1

### Conexiones de montaje

P1 = 1"1/2 - P2 = 1"1/4 - S = 4"		
	UNC	Metrica
T7EDB - P3 = 1"		M0
T7EDB - P3 = 3/4"		M1
T7EDBS - P3 = 1"	00	M0
T7EDBS - P3 = 3/4"	01	M1

### Modifiche

### Modificaciones