



Vane pumps Service information

vane-type double pump / Flügelzellen-Doppelpumpe

pompe double à palettes / pompa doppia a palette

tipo bomba de paletas doble

T7EB - T7EBS

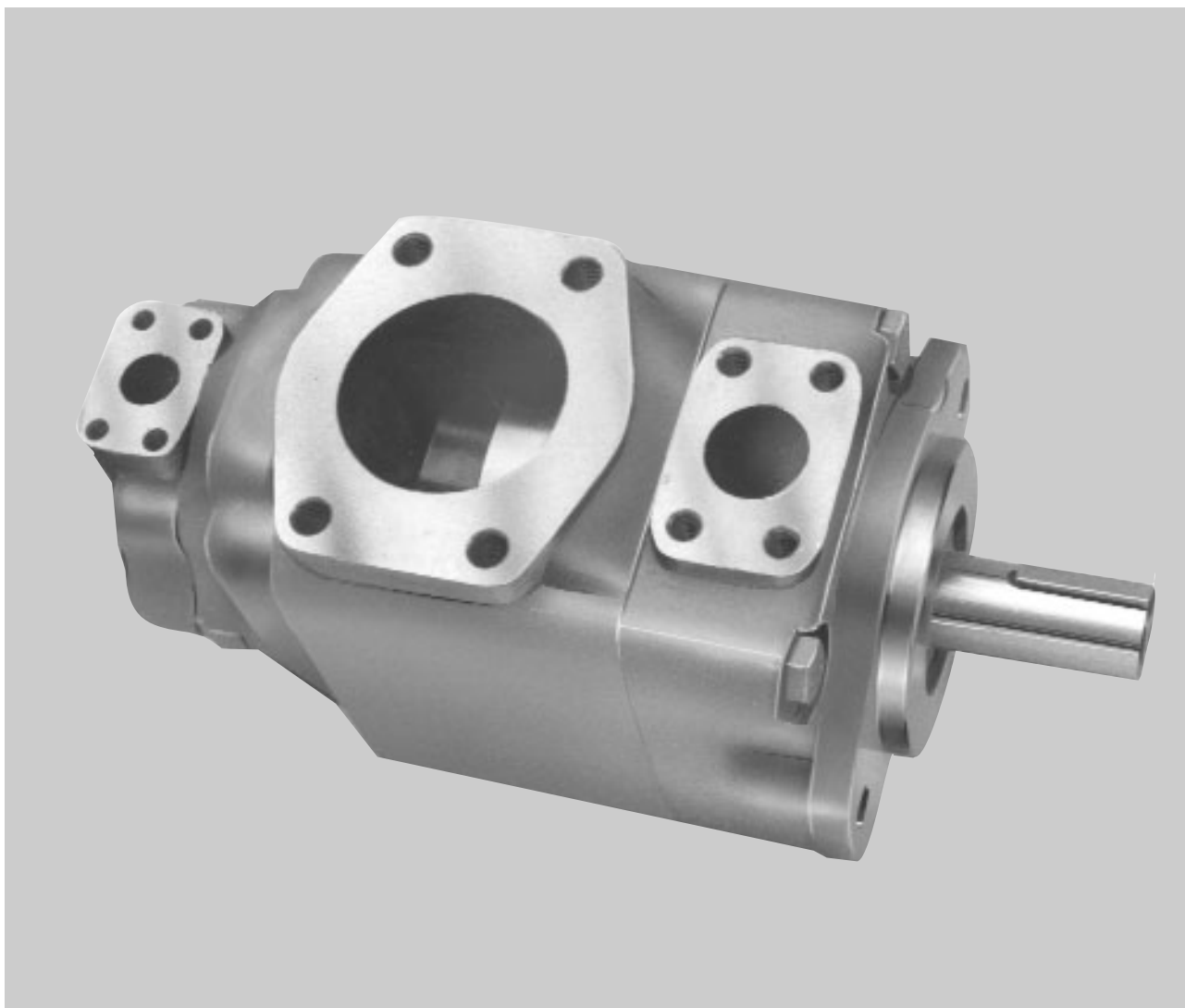

Publ. S1 - ML0618 - C 02 / 2003 / FB

Replaces : S1 - ML0618 - B

L25 - 10618 - 3

Recommended repair kits and assy's are bold printed
 Empfohlene Austausch - Baugruppen sind fett gedruckt
 Les pochettes de rechange recommandées sont imprimées en caractères gras
 I kit di ricambio consigliati sono indicati in grassetto
 Los juegos de reparacion recomendados y los conjuntos, estan en negrita

	Item - Pos. - Réf. - Pos.	
	22	35
Mounting torque		
Anziehdrehmoment	187 Nm	68 Nm
Couple de serrage	138 ft.lbs	50 ft.lbs
Coppia di serraggio		
Par de apriete		

T7EB - T7EBS

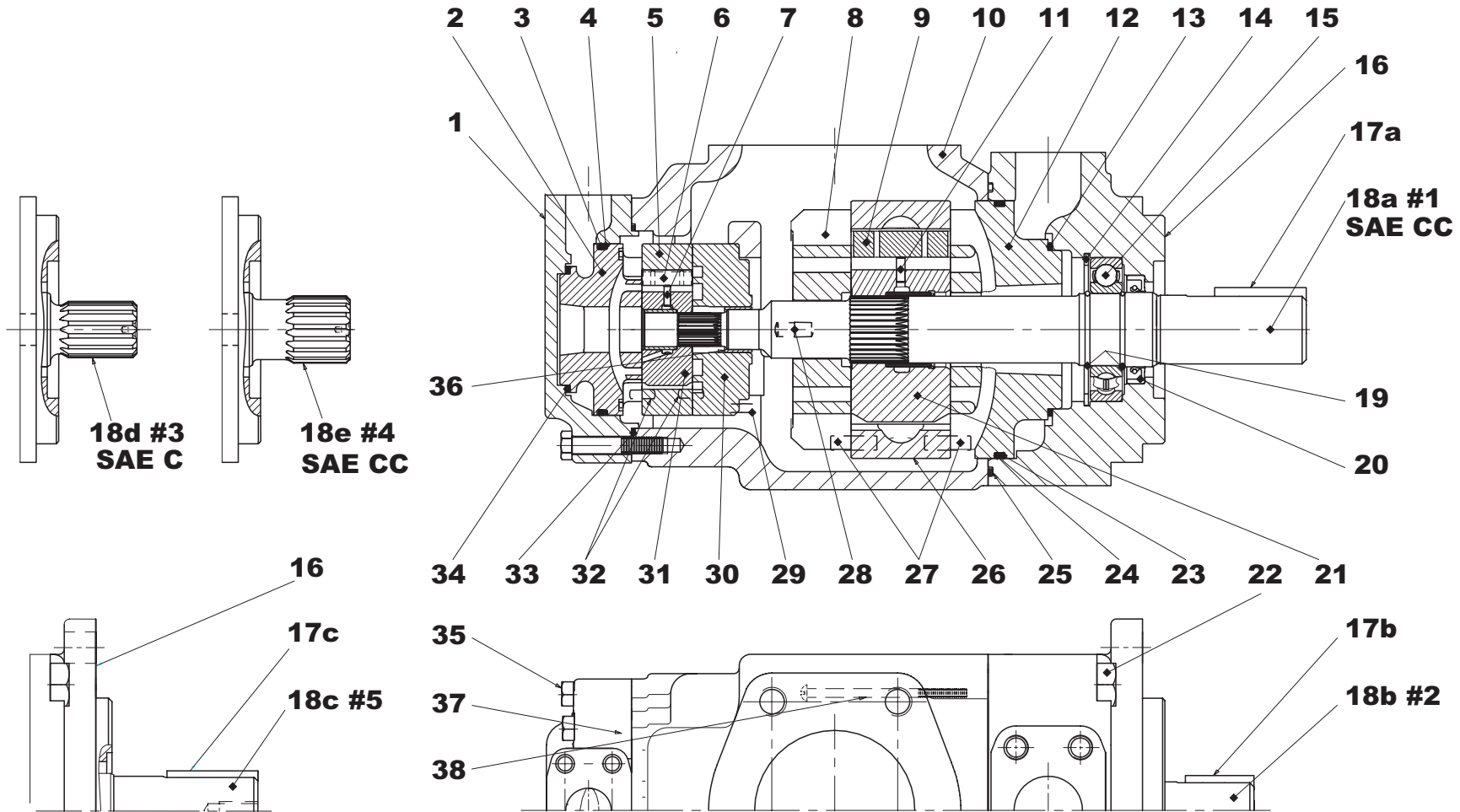

Item Pos. Pos. Pos.	Description Descrizione	Benennung Descripcion	Description	Part N° Teil Nr. Code N° Cod. N° Referencia T7EB	Part N° Teil Nr. Code N° Cod. N° Referencia T7EBS	Qty Stüçk Qté Q.tà Cant.	
1	End cap (metric) <i>Coperchio (metrica)</i>	Deckel (Metrisch) <i>Tapa (metrico)</i>	Chapeau (métrique)		034.66765	1	
	End cap (UNC) <i>Coperchio (UNC)</i>	Deckel (UNC) <i>Tapa (UNC)</i>	Chapeau (UNC)		034.66523	1	
2	Port plate-pressure <i>Piatto distributore anter.</i>	Steuerplatte <i>Plato distribuidor-presión</i>	Plaque pression	B	034.66923	1	
3	Sq. section seal <i>Guarnizione</i>	Dichtring <i>Junta seccion cuadrada</i>	Joint section carrée	BC	691.10238	1	
4	Back-up ring <i>Anello anti-estrusione</i>	Stützring <i>Anillo</i>	Bague anti-extrusion	BC	618.00010.3	1	
5	Cam ring 002 <i>Anello camma 002</i>	Hubring 002 <i>Aro volumetrico 002</i>	Came 002	B	034.66909	1	
	Cam ring 003 <i>Anello camma 003</i>	Hubring 003 <i>Aro volumetrico 003</i>	Came 003	B	034.66910	1	
	Cam ring 004 <i>Anello camma 004</i>	Hubring 004 <i>Aro volumetrico 004</i>	Came 004	B	034.66911	1	
	Cam ring 005 <i>Anello camma 005</i>	Hubring 005 <i>Aro volumetrico 005</i>	Came 005	B	034.66912	1	
	Cam ring 006 <i>Anello camma 006</i>	Hubring 006 <i>Aro volumetrico 006</i>	Came 006	B	034.66913	1	
	Cam ring 007 <i>Anello camma 007</i>	Hubring 007 <i>Aro volumetrico 007</i>	Came 007	B	034.67063	1	
	Cam ring 008 <i>Anello camma 008</i>	Hubring 008 <i>Aro volumetrico 008</i>	Came 008	B	034.66914	1	
	Cam ring 009 <i>Anello camma 009</i>	Hubring 009 <i>Aro volumetrico 009</i>	Came 009	B	034.67383	1	
	Cam ring 010 <i>Anello camma 010</i>	Hubring 010 <i>Aro volumetrico 010</i>	Came 010	B	034.66915	1	
	Cam ring 011 <i>Anello camma 011</i>	Hubring 011 <i>Aro volumetrico 011</i>	Came 011	B	034.67461	1	
	Cam ring 012 <i>Anello camma 012</i>	Hubring 012 <i>Aro volumetrico 012</i>	Came 012	B	034.67032	1	
	Cam ring 014 <i>Anello camma 014</i>	Hubring 014 <i>Aro volumetrico 014</i>	Came 014	B	034.67409	1	
	Cam ring 015 <i>Anello camma 015</i>	Hubring 015 <i>Aro volumetrico 015</i>	Came 015	B	034.67034	1	
	6	Vane <i>Paletta</i>	Flügel <i>Paleta</i>	Palette	B	034.66917	12
	7	Pin-vane holdout <i>Pistoncino di sostentamento</i>	Stößel <i>Espiga empuje paleta</i>	Poussoir de palette	B	034.66991	12
8	Port plate-rear C.C.W. <i>Piatto distributore post. antioraria</i>	Steuerplatte Linkslauf <i>Plato distribuidor trasero giro I</i>	Plaque arrière rotation gauche	AK	034.67435	1	
	Port plate-rear C.W. <i>Piatto distributore post. oraria</i>	Steuerplatte Rechtslauf <i>Plato distribuidor trasero giro D</i>	Plaque arrière rotation droite	AL	034.67407	1	
9	Vane <i>Paletta</i>	Flügel <i>Paleta</i>	Palette	A	034.59162	12	
10	Housing (standard) (metric) <i>Corpo (standard) (metrico)</i>	Gehäuse (Standard) (Metrisch) <i>Cuerpo (estándar) (metrica)</i>	Carter (standard) (métrique)		034.66734	1	
	Housing (standard) (UNC) <i>Corpo (standard) (UNC)</i>	Gehäuse (Standard) (UNC) <i>Cuerpo (estándar) (UNC)</i>	Carter (standard) (UNC)		034.70263	1	

Item Pos. Pos. Pos.	Description Descrizione	Benennung Descripcion	Description		Part N° Teil Nr. Code N° Cod. N° Referencia T7EB	Part N° Teil Nr. Code N° Cod. N° Referencia T7EBS	Qty Stück Qté Q.tà Cant.
11	Pin-vane holdout <i>Pistoncino di sostentamento</i>	Stössel <i>Espiga empuje paleta</i>	Poussoir de palette	A		034.59161	12
12	Port plate-pressure C.C.W. <i>Piatto distributore anter. anterioraria</i>	Steuerplatte Linkslauf <i>Plato distribuidor-presión giro I</i>	Plaque pression rotation gauche	A		034.67434	1
	Port plate-pressure C.W. <i>Piatto distributore anter. oraria</i>	Steuerplatte Rechtslauf <i>Plato distribuidor-presión giro D</i>	Plaque pression rotation droite	A		034.67408	1
13	Sq. section seal <i>Guarnizione</i>	Dichtring <i>Junta seccion cuadrada</i>	Joint section carrée	AC		691.10237	1
14	Retaining ring <i>Anello elastico</i>	Sicherungsring <i>Anillo de retención</i>	Circlips			356.30315	1
15	Ball bearing <i>Cuscinetto a sfere</i>	Kugellager <i>Cojinete de bolas</i>	Roulement à billes	DE FGH		230.03208	1
16	Mounting cap (metric) <i>Coperchio (metrica)</i>	Deckel (Metrisch) <i>Tapa de montaje 1" (metrico)</i>	Chapeau de montage (métrique)		034.67646	034.66735	1
	Mounting cap (UNC) <i>Coperchio (UNC)</i>	Deckel (UNC) <i>Tapa de montaje (UNC)</i>	Chapeau de montage (UNC)			034.70265	1
17a	Key (code 1) <i>Chiavetta (codice 1)</i>	Paßfeder (Typ 1) <i>Chaveta (codigo 1)</i>	Clavette (code 1)	D		034.70330	1
17b	Key (code 2) <i>Chiavetta (codice 2)</i>	Paßfeder (Typ 2) <i>Chaveta (codigo 2)</i>	Clavette (code 2)	E		034.49676	1
17c	Key (code 5) <i>Chiavetta (codice 5)</i>	Paßfeder (Typ 5) <i>Chaveta (codigo 5)</i>	Clavette (code 5)	H		034.30168	1
18a	Shaft (keyed) (code1) (SAE CC) <i>Albero a chiavetta (codice 1) (SAE CC)</i>	Welle für Paßfeder (Typ 1) (SAE CC) <i>Eje chaveteado (codigo 1) (SAE CC)</i>	Arbre à clavette (code 1) (SAE CC)	D		034.71408	1
18b	Shaft (keyed) (code 2) <i>Albero a chiavetta (codice 2)</i>	Welle für Paßfeder (Typ 2) <i>Eje chaveteado (codigo 2)</i>	Arbre à clavette (code 2)	E		034.66891	1
18c	Shaft (keyed) (code 5) (ISO R775 - G38M) <i>Albero a chiavetta (codice 5) (ISO R775 - G38M)</i>	Welle für Paßfeder (Typ 5) (ISO R775 - G38M) <i>Eje chaveteado (codigo 5) (ISO R775 - G38M)</i>	Arbre à clavette (code 5) (ISO R775 - G38M)	H		034.67647	1
18d	Shaft (splined) (code 3) (SAE C) <i>Albero a scanalato (codice 3) (SAE C)</i>	Vielkeilwelle (Typ 3) (SAE C) <i>Eje estriado (codigo 3) (SAE C)</i>	Arbre à cannelures (code 3) (SAE C)	F		034.71315	1
18e	Shaft (splined) (code 4) (SAE CC) <i>Albero scanalato (codice 4) (SAE CC)</i>	Vielkeilwelle (Typ 4) (SAE CC) <i>Eje estriado (codigo 4) (SAE CC)</i>	Arbre à cannelures (code 4) (SAE CC)	G		034.71409	1
19	Round section ring <i>Anello elastico</i>	Sicherungsring <i>Anillo tórico</i>	Anneau	DE FGH		034.70866	2
20	Shaft seal (S1 - 0,7 bar) <i>Paraolio (S1 - 0,7 bar)</i>	Simmerring (S1 - 0,7 bar) <i>Reten eje (S1 - 0,7 bar)</i>	Joint d'arbre (S1 - 0,7 bar)	C		620.82064	1
	Shaft seal (S4 - S5 - 7 bar) <i>Paraolio (S4 - S5 - 7 bar)</i>	Simmerring (S4 - S5 - 7 bar) <i>Reten eje (S4 - S5 - 7 bar)</i>	Joint d'arbre (S4 - S5 - 7 bar)	C		620.82072	1
21	Rotor ass'y <i>Insieme rotore</i>	Rotor <i>Conjunto rotor</i>	Rotor ass,	A		S24,10185	1
22	Screw <i>Vite</i>	Schraube <i>Tornille</i>	Vis			306.40216	4
23	Sq. section seal <i>Guarnizione</i>	Dichtring <i>Junta seccion cuadrada</i>	Joint section carrée	AC		691.10253	1
24	Back-up ring <i>Anello anti-estrusione</i>	Stützring <i>Anillo</i>	Bague anti-extrusion	AC		618.00012.3	1
25	Sq. section seal <i>Guarnizione</i>	Dichtring <i>Junta seccion cuadrada</i>	Joint section carrée	AC		671.10259	1
26	Cam ring 042 <i>Anello camma 042</i>	Hubring 042 <i>Aro volumetrico 042</i>	Came 042	A		034.67503	1

Item Pos. Pos. Pos.	Description Descrizione	Benennung Descripcion	Description	Part N° Teil Nr. Code N° Cod. N° Referencia T7EB	Part N° Teil Nr. Code N° Cod. N° Referencia T7EBS	Qty Stück Qté Q.tà Cant.
A	Cart. and plate ass'y 042 C.C.W. (P1) <i>Ins. cart. 042 antioraria (P1)</i>	Pumpeneinheit 042 Linkslauf (P1) <i>Conjunto cart. y platos 042 giro i. (P1)</i>	Cart. et plaque ass. 042 rot. g. (P1)		S24.77676	1
A	Cart. and plate ass'y 045 C.W. (P1) <i>Ins. cart. 045 oraria (P1)</i>	Pumpeneinheit 045 Rechtslauf (P1) <i>Conjunto cart. y platos 045 giro d. (P1)</i>	Cart. et plaque ass. 045 rot. d. (P1)		S24.77677	1
A	Cart. and plate ass'y 045 C.C.W. (P1) <i>Ins. cart. 045 antioraria (P1)</i>	Pumpeneinheit 045 Linkslauf (P1) <i>Conjunto cart. y platos 045 giro i. (P1)</i>	Cart. et plaque ass. 045 rot. g. (P1)		S24.77678	1
A	Cart. and plate ass'y 050 C.W. (P1) <i>Ins. cart. 050 oraria (P1)</i>	Pumpeneinheit 050 Rechtslauf (P1) <i>Conjunto cart. y platos 050 giro d. (P1)</i>	Cart. et plaque ass. 050 rot. d. (P1)		S24.77679	1
A	Cart. and plate ass'y 050 C.C.W. (P1) <i>Ins. cart. 050 antioraria (P1)</i>	Pumpeneinheit 050 Linkslauf (P1) <i>Conjunto cart. y platos 050 giro i. (P1)</i>	Cart. et plaque ass. 050 rot. g. (P1)		S24.77680	1
A	Cart. and plate ass'y 052 C.W. (P1) <i>Ins. cart. 052 oraria (P1)</i>	Pumpeneinheit 052 Rechtslauf (P1) <i>Conjunto cart. y platos 052 giro d. (P1)</i>	Cart. et plaque ass. 052 rot. d. (P1)		S24.77681	1
A	Cart. and plate ass'y 052 C.C.W. (P1) <i>Ins. cart. 052 antioraria (P1)</i>	Pumpeneinheit 052 Linkslauf (P1) <i>Conjunto cart. y platos 052 giro i. (P1)</i>	Cart. et plaque ass. 052 rot. g. (P1)		S24.77682	1
A	Cart. and plate ass'y 054 C.W. (P1) <i>Ins. cart. 054 oraria (P1)</i>	Pumpeneinheit 054 Rechtslauf (P1) <i>Conjunto cart. y platos 054 giro d. (P1)</i>	Cart. et plaque ass. 054 rot. d. (P1)		S24.77683	1
A	Cart. and plate ass'y 054 C.C.W. (P1) <i>Ins. cart. 054 antioraria (P1)</i>	Pumpeneinheit 054 Linkslauf (P1) <i>Conjunto cart. y platos 054 giro i. (P1)</i>	Cart. et plaque ass. 054 rot. g. (P1)		S24.77684	1
A	Cart. and plate ass'y 057 C.W. (P1) <i>Ins. cart. 057 oraria (P1)</i>	Pumpeneinheit 057 Rechtslauf (P1) <i>Conjunto cart. y platos 057 giro d. (P1)</i>	Cart. et plaque ass. 057 rot. d. (P1)		S24.77685	1
A	Cart. and plate ass'y 057 C.C.W. (P1) <i>Ins. cart. 057 antioraria (P1)</i>	Pumpeneinheit 057 Linkslauf (P1) <i>Conjunto cart. y platos 057 giro i. (P1)</i>	Cart. et plaque ass. 057 rot. g. (P1)		S24.77686	1
A	Cart. and plate ass'y 062 C.W. (P1) <i>Ins. cart. 062 oraria (P1)</i>	Pumpeneinheit 062 Rechtslauf (P1) <i>Conjunto cart. y platos 062 giro d. (P1)</i>	Cart. et plaque ass. 062 rot. d. (P1)		S24.77687	1
A	Cart. and plate ass'y 062 C.C.W. (P1) <i>Ins. cart. 062 antioraria (P1)</i>	Pumpeneinheit 062 Linkslauf (P1) <i>Conjunto cart. y platos 062 giro i. (P1)</i>	Cart. et plaque ass. 062 rot. g. (P1)		S24.77688	1
A	Cart. and plate ass'y 066 C.W. (P1) <i>Ins. cart. 066 oraria (P1)</i>	Pumpeneinheit 066 Rechtslauf (P1) <i>Conjunto cart. y platos 066 giro d. (P1)</i>	Cart. et plaque ass. 066 rot. d. (P1)		S24.77689	1
A	Cart. and plate ass'y 066 C.C.W. (P1) <i>Ins. cart. 066 antioraria (P1)</i>	Pumpeneinheit 066 Linkslauf (P1) <i>Conjunto cart. y platos 066 giro i. (P1)</i>	Cart. et plaque ass. 066 rot. g. (P1)		S24.77690	1
A	Cart. and plate ass'y 072 C.W. (P1) <i>Ins. cart. 072 oraria (P1)</i>	Pumpeneinheit 072 Rechtslauf (P1) <i>Conjunto cart. y platos 072 giro d. (P1)</i>	Cart. et plaque ass. 072 rot. d. (P1)		S24.77691	1
A	Cart. and plate ass'y 072 C.C.W. (P1) <i>Ins. cart. 072 antioraria (P1)</i>	Pumpeneinheit 072 Linkslauf (P1) <i>Conjunto cart. y platos 072 giro i. (P1)</i>	Cart. et plaque ass. 072 rot. g. (P1)		S24.77692	1
A	Cart. and plate ass'y 085 C.W. (P1) <i>Ins. cart. 085 oraria (P1)</i>	Pumpeneinheit 085 Rechtslauf (P1) <i>Conjunto cart. y platos 085 giro d. (P1)</i>	Cart. et plaque ass. 085 rot. d. (P1)		S24.77693	1
A	Cart. and plate ass'y 085 C.C.W. (P1) <i>Ins. cart. 085 antioraria (P1)</i>	Pumpeneinheit 085 Linkslauf (P1) <i>Conjunto cart. y platos 085 giro i. (P1)</i>	Cart. et plaque ass. 085 rot. g. (P1)		S24.77694	1
B	Cart. and plate ass'y B02 C.W. (P2) <i>Ins. cart. B02 oraria (P2)</i>	Pumpeneinheit B02 Rechtslauf (P2) <i>Conjunto cart. y platos B02 giro d. (P2)</i>	Cart. et plaque ass. B02 rot. d. (P2)		S24.51513	1
B	Cart. and plate ass'y B02 C.C.W. (P2) <i>Ins. cart. B02 antioraria (P2)</i>	Pumpeneinheit B02 Linkslauf (P2) <i>Conjunto cart. y platos B02 giro i. (P2)</i>	Cart. et plaque ass. B02 rot. g. (P2)		S24.51514	1
B	Cart. and plate ass'y B03 C.W. (P2) <i>Ins. cart. B03 oraria (P2)</i>	Pumpeneinheit B03 Rechtslauf (P2) <i>Conjunto cart. y platos B03 giro d. (P2)</i>	Cart. et plaque ass. B03 rot. d. (P2)		S24.51515	1
B	Cart. and plate ass'y B03 C.C.W. (P2) <i>Ins. cart. B03 antioraria (P2)</i>	Pumpeneinheit B03 Linkslauf (P2) <i>Conjunto cart. y platos B03 giro i. (P2)</i>	Cart. et plaque ass. B03 rot. g. (P2)		S24.51516	1
B	Cart. and plate ass'y B04 C.W. (P2) <i>Ins. cart. B04 oraria (P2)</i>	Pumpeneinheit B04 Rechtslauf (P2) <i>Conjunto cart. y platos B04 giro d. (P2)</i>	Cart. et plaque ass. B04 rot. d. (P2)		S24.51517	1
B	Cart. and plate ass'y B04 C.C.W. (P2) <i>Ins. cart. B04 antioraria (P2)</i>	Pumpeneinheit B04 Linkslauf (P2) <i>Conjunto cart. y platos B04 giro i. (P2)</i>	Cart. et plaque ass. B04 rot. g. (P2)		S24.51518	1

Item Pos. Pos. Pos.	Description Descrizione	Benennung Descripcion	Description	Part N° Teil Nr. Code N° Cod. N° Referencia T7EB	Part N° Teil Nr. Code N° Cod. N° Referencia T7EBS	Qty Stück Qté Cant.
B	Cart. and plate ass'y B05 C.W. (P2) <i>Ins. cart. B05 oraria (P2)</i>	Pumpeneinheit B05 Rechtslauf (P2) <i>Conjunto cart. y platos B05 giro d. (P2)</i>	Cart. et plaque ass. B05 rot. d. (P2)		S24.51519	1
B	Cart. and plate ass'y B05 C.C.W. (P2) <i>Ins. cart. B05 antioraria (P2)</i>	Pumpeneinheit B05 Linkslauf (P2) <i>Conjunto cart. y platos B05 giro i. (P2)</i>	Cart. et plaque ass. B05 rot. g. (P2)		S24.51520	1
B	Cart. and plate ass'y B06 C.W. (P2) <i>Ins. cart. B06 oraria (P2)</i>	Pumpeneinheit B06 Rechtslauf (P2) <i>Conjunto cart. y platos B06 giro d. (P2)</i>	Cart. et plaque ass. B06 rot. d. (P2)		S24.51521	1
B	Cart. and plate ass'y B06 C.C.W. (P2) <i>Ins. cart. B06 antioraria (P2)</i>	Pumpeneinheit B06 Linkslauf (P2) <i>Conjunto cart. y platos B06 giro i. (P2)</i>	Cart. et plaque ass. B06 rot. g. (P2)		S24.51522	1
B	Cart. and plate ass'y B07 C.W. (P2) <i>Ins. cart. B07 oraria (P2)</i>	Pumpeneinheit B07 Rechtslauf (P2) <i>Conjunto cart. y platos B07 giro d. (P2)</i>	Cart. et plaque ass. B07 rot. d. (P2)		S24.59972	1
B	Cart. and plate ass'y B07 C.C.W. (P2) <i>Ins. cart. B07 antioraria (P2)</i>	Pumpeneinheit B07 Linkslauf (P2) <i>Conjunto cart. y platos B07 giro i. (P2)</i>	Cart. et plaque ass. B07 rot. g. (P2)		S24.59973	1
B	Cart. and plate ass'y B08 C.W. (P2) <i>Ins. cart. B08 oraria (P2)</i>	Pumpeneinheit B08 Rechtslauf (P2) <i>Conjunto cart. y platos B08 giro d. (P2)</i>	Cart. et plaque ass. B08 rot. d. (P2)		S24.51523	1
B	Cart. and plate ass'y B08 C.C.W. (P2) <i>Ins. cart. B08 antioraria (P2)</i>	Pumpeneinheit B08 Linkslauf (P2) <i>Conjunto cart. y platos B08 giro i. (P2)</i>	Cart. et plaque ass. B08 rot. g. (P2)		S24.51524	1
B	Cart. and plate ass'y B09 C.W. (P2) <i>Ins. cart. B09 oraria (P2)</i>	Pumpeneinheit B09 Rechtslauf (P2) <i>Conjunto cart. y platos B09 giro d. (P2)</i>	Cart. et plaque ass. B09 rot. d. (P2)		S24.77376	1
B	Cart. and plate ass'y B09 C.C.W. (P2) <i>Ins. cart. B09 antioraria (P2)</i>	Pumpeneinheit B09 Linkslauf (P2) <i>Conjunto cart. y platos B09 giro i. (P2)</i>	Cart. et plaque ass. B09 rot. g. (P2)		S24.77377	1
B	Cart. and plate ass'y B10 C.W. (P2) <i>Ins. cart. B10 oraria (P2)</i>	Pumpeneinheit B10 Rechtslauf (P2) <i>Conjunto cart. y platos B10 giro d. (P2)</i>	Cart. et plaque ass. B10 rot. d. (P2)		S24.51525	1
B	Cart. and plate ass'y B10 C.C.W. (P2) <i>Ins. cart. B10 antioraria (P2)</i>	Pumpeneinheit B10 Linkslauf (P2) <i>Conjunto cart. y platos B10 giro i. (P2)</i>	Cart. et plaque ass. B10 rot. g. (P2)		S24.51526	1
B	Cart. and plate ass'y B11 C.W. (P2) <i>Ins. cart. B11 oraria (P2)</i>	Pumpeneinheit B11 Rechtslauf (P2) <i>Conjunto cart. y platos B11 giro d. (P2)</i>	Cart. et plaque ass. B11 rot. d. (P2)		S24.77378	1
B	Cart. and plate ass'y B11 C.C.W. (P2) <i>Ins. cart. B11 antioraria (P2)</i>	Pumpeneinheit B11 Linkslauf (P2) <i>Conjunto cart. y platos B11 giro i. (P2)</i>	Cart. et plaque ass. B11 rot. g. (P2)		S24.77379	1
B	Cart. and plate ass'y B12 C.W. (P2) <i>Ins. cart. B12 oraria (P2)</i>	Pumpeneinheit B12 Rechtslauf (P2) <i>Conjunto cart. y platos B12 giro d. (P2)</i>	Cart. et plaque ass. B12 rot. d. (P2)		S24.59017	1
B	Cart. and plate ass'y B12 C.C.W. (P2) <i>Ins. cart. B12 antioraria (P2)</i>	Pumpeneinheit B12 Linkslauf (P2) <i>Conjunto cart. y platos B12 giro i. (P2)</i>	Cart. et plaque ass. B12 rot. g. (P2)		S24.59018	1
B	Cart. and plate ass'y B14 C.W. (P2) <i>Ins. cart. B14 oraria (P2)</i>	Pumpeneinheit B14 Rechtslauf (P2) <i>Conjunto cart. y platos B14 giro d. (P2)</i>	Cart. et plaque ass. B14 rot. d. (P2)		S24.77380	1
B	Cart. and plate ass'y B14 C.C.W. (P2) <i>Ins. cart. B14 antioraria (P2)</i>	Pumpeneinheit B14 Linkslauf (P2) <i>Conjunto cart. y platos B14 giro i. (P2)</i>	Cart. et plaque ass. B14 rot. g. (P2)		S24.77381	1
B	Cart. and plate ass'y B15 C.W. (P2) <i>Ins. cart. B15 oraria (P2)</i>	Pumpeneinheit B15 Rechtslauf (P2) <i>Conjunto cart. y platos B15 giro d. (P2)</i>	Cart. et plaque ass. B15 rot. d. (P2)		S24.59019	1
B	Cart. and plate ass'y B15 C.C.W. (P2) <i>Ins. cart. B15 antioraria (P2)</i>	Pumpeneinheit B15 Linkslauf (P2) <i>Conjunto cart. y platos B15 giro i. (P2)</i>	Cart. et plaque ass. B15 rot. g. (P2)		S24.59020	1
C	Seal kit (S1 - 0,7 bar) <i>Serie guarnizioni (S1 - 0,7 bar)</i>	Dichtringsatz (S1 - 0,7 bar) <i>Juego de juntas (S1 - 0,7 bar)</i>	Pochette de joint (S1 - 0,7 bar)		S24.10242	1
C	Seal kit (S4 - 7 bar) <i>Serie guarnizioni (S4 - 7 bar)</i>	Dichtringsatz (S4 - 7 bar) <i>Juego de juntas (S4 - 7 bar)</i>	Pochette de joint (S4 - 7 bar)		S24.10242.4	1
C	Seal kit (S5 - 7 bar) <i>Serie guarnizioni (S5 - 7 bar)</i>	Dichtringsatz (S5 - 7 bar) <i>Juego de juntas (S5 - 7 bar)</i>	Pochette de joint (S5 - 7 bar)		S24.10242.5	1
D	Shaft and bearing ass'y (code 1) <i>Ins. albero (codice 1)</i>	Baugruppe (Welle u. Lager) (Typ 1) <i>Conjunto eje cojinete (codigo 1)</i>	Arbre et roulement ass. (code 1)		S14.28178	1
E	Shaft and bearing ass'y (code 2) <i>Ins. albero (codice 2)</i>	Baugruppe (Welle u. Lager) (Typ 2) <i>Conjunto eje cojinete (codigo 2)</i>	Arbre et roulement ass. (code 2)		S24.49213	1

Item Pos. Réf. Pos. Pos.	Description <i>Descrizione</i>	Benennung <i>Descripcion</i>	Description	Part N° Teil Nr. Code N° Cod. N° Referencia T7EB	Part N° Teil Nr. Code N° Cod. N° Referencia T7EBS	Qty Stück Qté Q.tà Cant.
F	Shaft and bearing ass'y (code 3) <i>Ins. albero (codice 3)</i>	Baugruppe (Welle u. Lager) (Typ 3) <i>Conjunto eje cojinete (codigo 3)</i>	Arbre et roulement ass. (code 3)		S14.28176	1
G	Shaft and bearing ass'y (code 4) <i>Ins. albero (codice 4)</i>	Baugruppe (Welle u. Lager) (Typ 4) <i>Conjunto eje cojinete (codigo 4)</i>	Arbre et roulement ass. (code 4)		S14.28177	1
H	Shaft and bearing ass'y (code 5) <i>Ins. albero (codice 5)</i>	Baugruppe (Welle u. Lager) (Typ 5) <i>Conjunto eje cojinete (codigo 5)</i>	Arbre et roulement ass. (code 5)		S24.77721	1
J	Port plate rear ass'y <i>Ins. piatto distributore post.</i>	Steuerplatte <i>Conj. plato dist. Trasero</i>	Plaque arrière ass.		S24.51527	1
K	Port plate rear ass'y C.C.W. <i>Ins. piatto distributore post. antioraria</i>	Steuerplatte Linkslauf <i>Conj. plato dist. trasero giro I</i>	Plaque arrière ass. rot. gauche		S24.76213	1
L	Port plate rear ass'y C.W. <i>Ins. piatto distributore post. oraria</i>	Steuerplatte Rechtslauf <i>Conj. plato dist. trasero giro D</i>	Plaque arrière ass. rot. droite		S24.73820	1

Model Code

Typenschlüssel

Désignation - type

Model number

Typenbezeichnung :

Numéro du modèle : **T7EB or T7EBS . - 042 - B12 - 1 R 00 - A 1 M1 - ..**

T7EB series - ISO 2 bolts 3019-2
125 A2 HW
T7EBS series - SAE C - 2 bolts
Mounting flange J744

Baureihe T7EB - ISO 2-Loch 3019-2
125 A2 HW
Baureihe T7EBS - SAE C 2-Loch
Montageflansch, J744

Série T7EB - ISO 2 trous 3019-2
125 A2 HW
Série T7EBS - SAE C 2 trous
Bride de montage J744

One letter can be added to specify special parts in series

Optionen

Une lettre peut être ajoutée pour spécifier les pièces spéciales dans la série.

Cam ring for P1

(Volumetric displacement) (ml/rev.)

042 = 132,3
045 = 142,4
050 = 158,5
052 = 164,8

Hubring P1

(Geometrisches Fördervolumen) (cm³/U)

054 = 171,0
057 = 183,3
062 = 196,7

Came pour P1

(Cylindree théorique) (cm³/tr)

066 = 213,3
072 = 227,1
085 = 268,7

Cam ring for P2

(Volumetric displacement) (ml/rev.)

B02 = 5,8
B03 = 9,8
B04 = 12,8
B05 = 15,9
B06 = 19,8

Hubring P2

(Geometrisches Fördervolumen) (cm³/U)

B07 = 22,5
B08 = 24,9
B09 = 28,0
B10 = 31,8

Came pour P2

(Cylindree théorique) (cm³/tr)

B11 = 35,0
B12 = 41,0
B14 = 45,0
B15 = 50,0

Type of shaft T7EBS

1 = keyed (SAE CC)
2 = keyed (non SAE)
3 = splined 12/24 (SAE C)
4 = splined 12/24 (SAE CC)

Art der Welle T7EBS

1 = Paßfederwelle (SAE CC)
2 = Paßfederwelle (nicht SAE)
3 = Vielkeilwelle 12/24 (SAE C)
4 = Vielkeilwelle 12/24 (SAE CC)

Type d'arbre T7EBS

1 = à clavette (SAE CC)
2 = à clavette (non SAE)
3 = à cannelures 12/24 (SAE C)
4 = à cannelures 12/24 (SAE CC)

Type of shaft T7EB & T7EBS

5 = keyed (ISO R775 - G38M)

Art der Welle T7EB & T7EBS

5 = Paßfederwelle (ISO R775 - G38M)

Type d'arbre T7EB & T7EBS

5 = à clavette (ISO R775 - G38M)

Direction of rotation

R = Clockwise
L = Counter-clockwise

Drehrichtung

R = Rechtslauf
L = Linkslauf

Sens de rotation

R = à droite
L = à gauche

Porting combination

00 = standard

Lage der Anschlüsse

00 = standard

Combinaison des orifices

00 = standard

Design letter

Ausführungsbuchstabe

Conception

Seal class

1 = S1 - BUNA N
4 = S4 - EPDM
5 = S5 - VITON

Dichtungsklasse

1 = S1 - BUNA N
4 = S4 - EPDM
5 = S5 - VITON

Classe de joint

1 = S1 - BUNA N
4 = S4 - EPDM
5 = S5 - VITON

Mounting w/connection variables

4 bolts SAE flanges (J518)

	P1 = 1"1/2 - P2 = 3/4" - S = 3"1/2	
	UNC	Metric
T7EB		M1
T7EBS	01	M1

Gehäuse-Anschlußgröße

SAE-Vierlochflansch (J518)

	P1 = 1"1/2 - P = 3/4" - S = 3"1/2	
	UNC	Metrisches
T7EB		M1
T7EBS	01	M1

Option sur orifices

Bride SAE 4 trous (J518)

	P1 = 1"1/2 - P = 3/4" - S = 3"1/2	
	UNC	Métrique
T7EB		M0
T7EBS	00	M0

Modifications

Modifikationen

Modifications

Designazione

Clave de designación

Sigla :

Serie T7EB - ISO 2 fori 3019-2
125 A2 HW
Serie T7EBS - SAE C 2 fori
Flangia di montaggio J744

Referencia modelo :

Serie T7EB - ISO 2 taladros 3019-2
125 A2 HW
Serie T7EBS - SAE C 2 taladros
Brida de montaje J744

T7EB or T7EBS - **042** - **B12** - **1** **R** **00** - **A** **1** **M1** - ..

Una lettera può essere aggiunta per specificare parti speciali nella serie

Una letra puede ser añadida para especificar piezas especiales en la serie

Tipo di cartuccia P1

(Cilindrata) (ml/ giro)
042 = 132,3
045 = 142,4
050 = 158,5
052 = 164,8
054 = 171,0

Aro volumetrico para P1

(Cilindrada) (ml/rev)
057 = 183,3
062 = 196,7
066 = 213,3
072 = 227,1
085 = 268,7

Tipo di cartuccia P2

(Cilindrata) (ml/ giro)
B02 = 5,8
B03 = 9,8
B04 = 12,8
B05 = 15,9
B06 = 19,8
B07 = 22,5
B08 = 24,9

Aro volumetrico para P2

(Cilindrada) (ml/rev)
B09 = 28,0
B10 = 31,8
B11 = 35,0
B12 = 41,0
B14 = 45,0
B15 = 50,0

Tipo di albero T7EBS

1 = a chiavetta (SAE CC)
2 = a chiavetta
3 = scanalato 12/24 (SAE C)
4 = scanalato 12/24 (SAE CC)

Tipo de eje T7EBS

1 = chaveteado (SAE CC)
2 = chaveteado (no SAE)
3 = estriado 12/24 (SAE C)
4 = estriado 12/24 (SAE CC)

Tipo di albero T7EB & T7EBS

5 = a chiavetta (ISO R775 - G38M)

Tipo de eje T7EB & T7EBS

5 = chaveteado (ISO R775 - G38M)

Senso di rotazione

R = Orario
L = Antiorario

Sentido de giro

R = Derecha
L = Izquierda

Orientamento delle bocche

00 = standard

Posición de bocas

00 = estándar

Diseño

Letra de diseño

Tipo di guarnizioni

1 = S1 - BUNA N
4 = S4 - EPDM
5 = S5 - VITON

Clase de juntas

1 = S1 - BUNA N
4 = S4 - EPDM
5 = S5 - VITON

Dimensioni delle bocche

Flangia SAE 4 drenaggio (J518)

	P1 = 1"1/2 - P = 3/4" - S = 3"1/2	
	UNC	Metrica
T7EB		M0
T7EBS	00	M0

Opciones de las bocas

Brida SAE 4 taladros (J518)

	P1 = 1"1/2 - P = 3/4" - S = 3"1/2	
	UNC	Metrico
T7EB		M0
T7EBS	00	M0

Modifiche

Modificaciones