



Vane pumps Service information

vane-type double pump / Flügelzellen-Doppelpumpe

pompe double à palettes / pompa doppia a palette

tipo bomba de paletas doble

T7DD - T7DDS

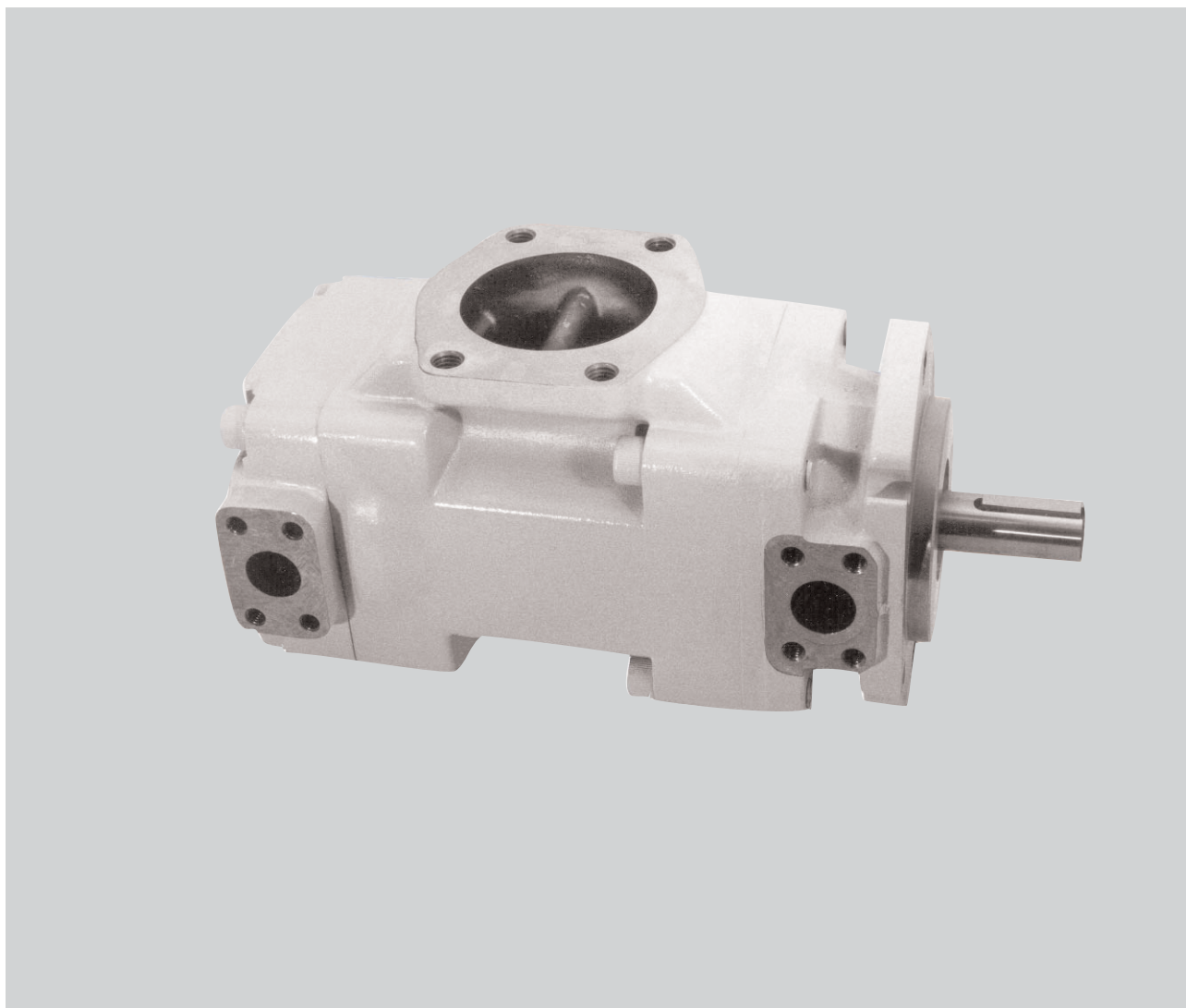

Publ. S1 - ML0605 - D 09 / 2004 / FB

Replaces : S1 - ML0605 - C

L25 - 10605 - 4

Recommended repair kits and assy's are bold printed
 Empfohlene Austausch - Baugruppen sind fett gedruckt
 Les pochettes de rechange recommandées sont imprimées en caractères gras
 I kit di ricambio consigliati sono indicati in grassetto
 Los juegos de reparacion recomendados y los conjuntos, estan en negrita

	Item - Pos. - Réf. - Pos.
	25
Mounting torque	
Anziehdrehmoment	190 Nm
Couple de serrage	140 ft.lbs
Coppia di serraggio	
Par de apriete	

T7DD - T7DDS

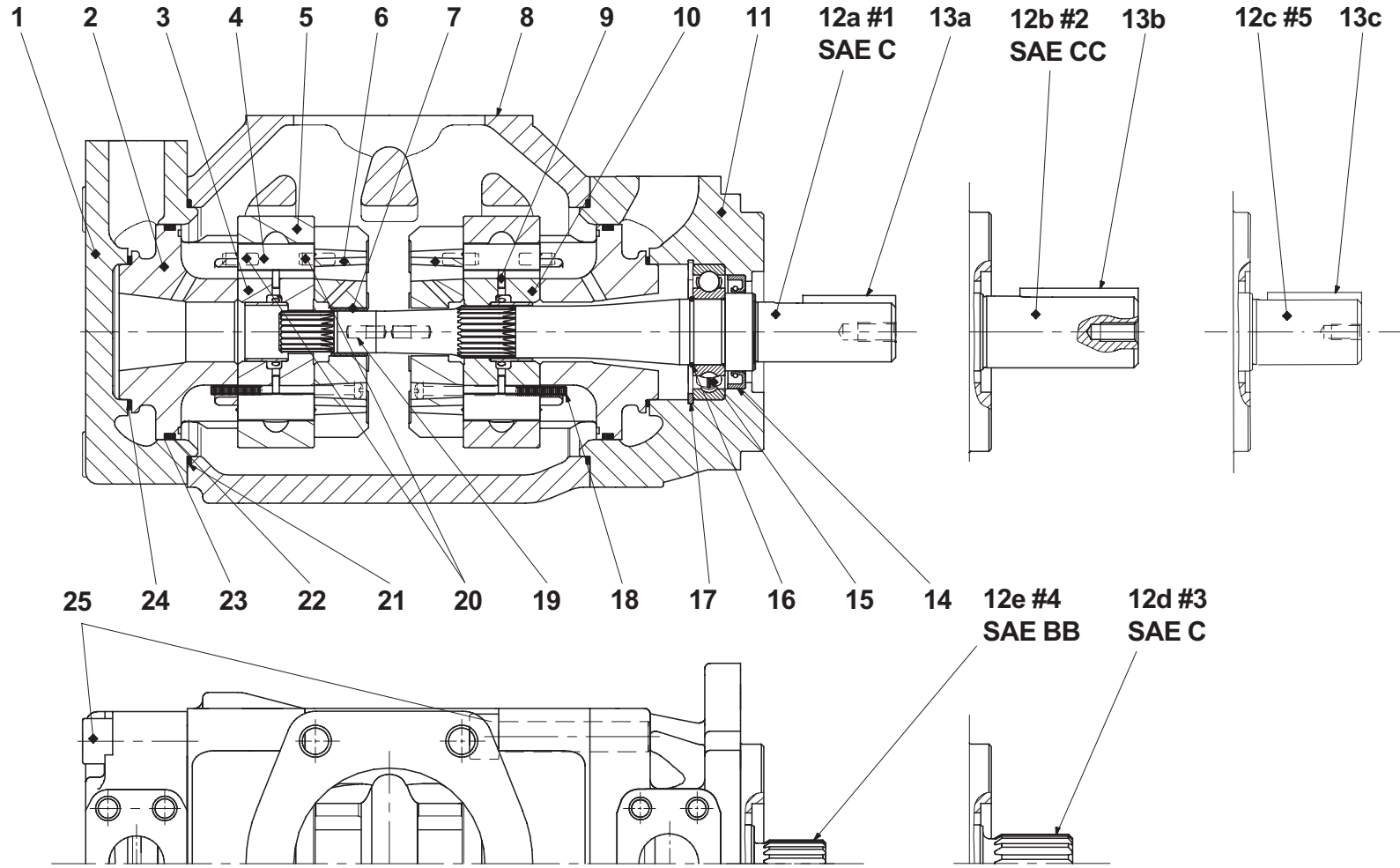

Item Pos. Réf. Pos. Pos.	Description Descrizione	Benennung Descripcion	Description		Part N° Teil Nr. Code N° Referencia T7DD	Part N° Teil Nr. Code N° Referencia T7DDS	Qty Stück Qté Q.tà Cant.	
1	End cap (metric - M0) <i>Coperchio (metrica - M0)</i>	Deckel (Metrisch - M0) <i>Tapa (metrico - M0)</i>	Chapeau (métrique - M0)		034.66894		1	
	End cap (UNC - 00) <i>Coperchio (UNC - 00)</i>	Deckel (UNC - 00) <i>Tapa (UNC - 00)</i>	Chapeau (UNC - 00)			034.70275	1	
2	Port plate-pressure (Except cam rings 045 - 050) <i>Piatto distributore anter. (Eccetto anello camma 045-050)</i>	Steuerplatte (außer Hubringe 045 - 050) <i>Plato distribuidor-presión (Excepto los aros 045 - 050)</i>	Plaque pression (Excepté cames 045 - 050)	A	034.67479		2	
2 (P1)	Port plate-pressure C.C.W. (Only cam rings 045 - 050) <i>Piatto distributore anter. antioraria (Solo anello camma 045-050)</i>	Steuerplatte Linkslauf (nur Hubringe 045 - 050) <i>Plato distribuidor-presión giro I (Solo los aros 045 - 050)</i>	Plaque press. rot. gauche (Seulement cames 045-050)	A	034.67113		1	
	Port plate-pressure C.W. (Only cam rings 045 - 050) <i>Piatto distributore anter. oraria (Solo anello camma 045-050)</i>	Steuerplatte Rechtslauf (nur Hubringe 045 - 050) <i>Plato distribuidor-presión giro D (Solo los aros 045 - 050)</i>	Plaque press. rot. droite (Seulement cames 045-050)	A	034.67111		1	
2 (P2)	Port plate-pressure C.C.W. (Only cam rings 045 - 050) <i>Piatto distributore anter. antioraria (Solo anello camma 045-050)</i>	Steuerplatte Linkslauf (nur Hubringe 045 - 050) <i>Plato distribuidor-presión giro I (Solo los aros 045 - 050)</i>	Plaque press. rot. gauche (Seulement cames 045-050)	B	034.67111		1	
	Port plate-pressure C.W. (Only cam rings 045 - 050) <i>Piatto distributore anter. oraria (Solo anello camma 045-050)</i>	Steuerplatte Rechtslauf (nur Hubringe 045 - 050) <i>Plato distribuidor-presión giro D (Solo los aros 045 - 050)</i>	Plaque press. rot. droite (Seulement cames 045-050)	B	034.67113		1	
3	Rotor-insert ass'y (Except cam rings 045 - 050) <i>Insieme rotore (Eccetto anello camma 045 - 050)</i>	Rotor (außer Hubringe 045 - 050) <i>Conjunto rotor (Excepto los aros 045 - 050)</i>	Rotor et douille ass. (Excepté cames 045 - 050)	B	S24.76913		1	
	Rotor-insert ass'y (Only cam rings 045 - 050) <i>Insieme rotore (Solo anello camma 045 - 050)</i>	Rotor (nur Hubringe 045 - 050) <i>Conjunto rotor (Solo los aros 045 - 050)</i>	Rotor et douille ass. (Seulement cames 045 - 050)	B	S24.51350		1	
4	Vane (Except cam rings 045 - 050) <i>Paletta (Eccetto anello camma 045 - 050)</i>	Flügel (außer Hubringe 045 - 050) <i>Paleta (Excepto los aros 045 - 050)</i>	Palette (Excepté cames 045 - 050)	AB	034.67453		24	
	Vane (Only cam rings 045 - 050) <i>Paletta (Solo anello camma 045 - 050)</i>	Flügel (nur Hubringe 045 - 050) <i>Paleta (Solo los aros 045 - 050)</i>	Palette (Seulement cames 045 - 050)	AB	034.53588		24	
5	Cam ring 014 <i>Anello camma 014</i>	Hubring 014 <i>Aro volumetrico 014</i>	Came 014	AB	034.67469		2	
	Cam ring 017 <i>Anello camma 017</i>	Hubring 017 <i>Aro volumetrico 017</i>	Came 017	AB	034.67470		2	
	Cam ring 020 <i>Anello camma 020</i>	Hubring 020 <i>Aro volumetrico 020</i>	Came 020	AB	034.67159		2	
	Cam ring 022 <i>Anello camma 022</i>	Hubring 022 <i>Aro volumetrico 022</i>	Came 022	AB	034.67482		2	
	Cam ring 024 <i>Anello camma 024</i>	Hubring 024 <i>Aro volumetrico 024</i>	Came 024	AB	034.67158		2	
	Cam ring 028 <i>Anello camma 028</i>	Hubring 028 <i>Aro volumetrico 028</i>	Came 028	AB	034.67157		2	
	Cam ring 031 <i>Anello camma 031</i>	Hubring 031 <i>Aro volumetrico 031</i>	Came 031	AB	034.67156		2	
	Cam ring 035 <i>Anello camma 035</i>	Hubring 035 <i>Aro volumetrico 035</i>	Came 035	AB	034.67155		2	
	Cam ring 038 <i>Anello camma 038</i>	Hubring 038 <i>Aro volumetrico 038</i>	Came 038	AB	034.67154		2	
	Cam ring 042 <i>Anello camma 042</i>	Hubring 042 <i>Aro volumetrico 042</i>	Came 042	AB	034.67153		2	
	Cam ring 045 <i>Anello camma 045</i>	Hubring 045 <i>Aro volumetrico 045</i>	Came 045	AB	034.59131		2	
	Cam ring 050 <i>Anello camma 050</i>	Hubring 050 <i>Aro volumetrico 050</i>	Came 050	AB	034.66737		2	
	6	Port plate-rear (Except cam rings 045 - 050) <i>Piatto distributore post. (Eccetto anello camma 045 - 050)</i>	Steuerplatte (außer Hubringe 045 - 050) <i>Plato distribuidor trasero (Excepto los aros 045 - 050)</i>	Plaque arrière (Excepté cames 045 - 050)	AL	034.67478		2
	6 (P1)	Port plate-rear C.C.W. (Only cam rings 045 - 050) <i>Piatto distributore post. antioraria (Solo anello camma 045-050)</i>	Steuerplatte Linkslauf (nur Hubringe 045 - 050) <i>Plato distribuidor trasero giro I (Solo los aros 045 - 050)</i>	Plaque arr. rot. gauche (Seulement cames 045 - 050)	AM	034.67114		1

Item Pos. Réf. Pos. Pos.	Description Descrizione	Benennung Descripcion	Description		Part N° Teil Nr. Code N° Referencia 17DD	Part N° Teil Nr. Code N° Referencia 17DDS	Qty Stück Qté Q.tà Cant.
6 (P1)	Port plate-rear C.W. (Only cam rings 045 - 050) <i>Piatto distributore post. oraria (Solo anello camma 045-050)</i>	Steuerplatte Rechtslauf (nur Hubringe 045 - 050) <i>Piatio distribuidor trasero giro D (Solo los aros 045 - 050)</i>	Plaque arr. rot. droite (Seulement comes 045 - 050)	AN	034.67112		1
6 (P2)	Port plate-rear C.C.W. (Only cam rings 045 - 050) <i>Piatto distributore post. antioraria (Solo anello camma 045-050)</i>	Steuerplatte Linkslauf (nur Hubringe 045 - 050) <i>Plato distribuidor trasero giro I (Solo los aros 045 - 050)</i>	Plaque arr. rot. gauche (Seulement comes 045 - 050)	BJ	034.67112		1
	Port plate-rear C.W. (Only cam rings 045 - 050) <i>Piatto distributore post. oraria (Solo anello camma 045-050)</i>	Steuerplatte Rechtslauf (nur Hubringe 045 - 050) <i>Piatio distribuidor trasero giro D (Solo los aros 045 - 050)</i>	Plaque arr. rot. droite (Seulement comes 045 - 050)	BK	034.67114		1
7	Bush <i>Bussola</i>	Buchse <i>Cojinete de fricción</i>	Bague	BIKJ	034.70868		1
8	Housing (metric) <i>Corpo (metrico)</i>	Gehäuse (Metrisch) <i>Cuerpo (metrica)</i>	Carter (métrique)		034.67340		1
	Housing (UNC) <i>Corpo (UNC)</i>	Gehäuse (UNC) <i>Cuerpo (UNC)</i>	Carter (UNC)			034.67341	1
9	Pin-vane holdout (Except cam rings 045 - 050) <i>Pistoncino di sostentamento (Eccetto anello camma 045-050)</i>	Stößel (außer Hubringe 045 - 050) <i>Espiga empuje paleta (Excepto los aros 045 - 050)</i>	Poussoir de palette (Excepté comes 045 - 050)	AB	034.59098		24
	Pin-vane holdout (Only cam rings 045 - 050) <i>Pistoncino di sostentamento (Solo anello camma 045-050)</i>	Stößel (nur Hubringe 045 - 050) <i>Espiga empuje paleta (Solo los aros 045 - 050)</i>	Poussoir de palette (Seulement comes 045 - 050)	AB	034.59130		24
10	Rotor-insert ass'y (Except cam rings 045 - 050) <i>Insieme rotore (Eccetto anello camma 045 - 050)</i>	Rotor (außer Hubringe 045 - 050) <i>Conjunto rotor (Excepto los aros 045 - 050)</i>	Rotor et douille ass. (Excepté comes 045 - 050)	A	S24.73783		1
	Rotor-insert ass'y (Only cam rings 045 - 050) <i>Insieme rotore (Solo anello camma 045 - 050)</i>	Rotor (nur Hubringe 045 - 050) <i>Conjunto rotor (Solo los aros 045 - 050)</i>	Rotor et douille ass. (Seulement comes 045 - 050)	A	S24.10121		1
11	Mounting cap (metric - M0) <i>Coperchio (metrica - M0)</i>	Deckel (Metrisch - M0) <i>Tapa de montaje 1" (metrico - M0)</i>	Chapeau de montage (métrique - M0)		034.67571	034.67695	1
	Mounting cap (UNC - 00) <i>Coperchio (UNC - 00)</i>	Deckel (UNC - 00) <i>Tapa de montaje (UNC - 00)</i>	Chapeau de montage (UNC - 00)			034.67696	1
12a	Shaft (keyed) (code1) (SAE C) <i>Albero a chiavetta (codice 1) (SAE C)</i>	Welle für Paßfeder (Typ 1) (SAE C) <i>Eje chaveteado (codigo 1) (SAE C)</i>	Arbre à clavette (code 1) (SAE C)	D		034.67344	1
12b	Shaft (keyed) (code 2) (SAE CC) <i>Albero a chiavetta (codice 2) (SAE CC)</i>	Welle für Paßfeder (Typ 2) (SAE CC) <i>Eje chaveteado (codigo 2) (SAE CC)</i>	Arbre à clavette (code 2) (SAE CC)	E		034.67345	1
12c	Shaft (keyed) (code 5) (ISO 3019-2 - G32M) <i>Albero a chiavetta (codice 5) (ISO 3019-2 - G32M)</i>	Welle für Paßfeder (Typ 5) (ISO 3019-2 - G32M) <i>Eje chaveteado (codigo 5) (ISO 3019-2 - G32M)</i>	Arbre à clavette (code 5) (ISO 3019-2 - G32M)	H	034.67570		1
12d	Shaft (splined) (code 3) (SAE C) <i>Albero a scanalato (codice 3) (SAE C)</i>	Vielkeilwelle (Typ 3) (SAE C) <i>Eje estriado (codigo 3) (SAE C)</i>	Arbre à cannelures (code 3) (SAE C)	F		034.67347	1
12e	Shaft (splined) (code 4) (SAE BB) <i>Albero scanalato (codice 4) (SAE BB)</i>	Vielkeilwelle (Typ 4) (SAE BB) <i>Eje estriado (codigo 4) (SAE BB)</i>	Arbre à cannelures (code 4) (SAE BB)	G		034.67348	1
13a	Key (code 1) <i>Chiavetta (codice 1)</i>	Paßfeder (Typ 1) <i>Chaveta (codigo 1)</i>	Clavette (code 1)	D		034.46754	1
13b	Key (code 2) <i>Chiavetta (codice 2)</i>	Paßfeder (Typ 2) <i>Chaveta (codigo 2)</i>	Clavette (code 2)	E		034.70330	1
13c	Key (code 5) <i>Chiavetta (codice 5)</i>	Paßfeder (Typ 5) <i>Chaveta (codigo 5)</i>	Clavette (code 5)	H	034.30168		1
14	Shaft seal (S1 - 0,7 bar) <i>Paraolio (S1 - 0,7 bar)</i>	Simmerring (S1 - 0,7 bar) <i>Reten eje (S1 - 0,7 bar)</i>	Joint d'arbre (S1 - 0,7 bar)	C	620.82064		1
	Shaft seal (S4 - 7 bar) <i>Paraolio (S4 - 7 bar)</i>	Simmerring (S4 - 7 bar) <i>Reten eje (S4 - 7 bar)</i>	Joint d'arbre (S4 - 7 bar)	C	620.82072		1
	Shaft seal (S5 - 7 bar) <i>Paraolio (S5 - 7 bar)</i>	Simmerring (S5 - 7 bar) <i>Reten eje (S5 - 7 bar)</i>	Joint d'arbre (S5 - 7 bar)	C	620.82072		1
15	Ball bearing <i>Cuscinetto a sfere</i>	Kugellager <i>Cojinete de bolas</i>	Roulement à billes	DEF GH	230.00207		1
16	Round section ring <i>Anello elastico</i>	Sicherungsring <i>Anillo tórico</i>	Anneau	DEF GH	034.70853		1

Item Pos. Réf. Pos. Pos.	Description Descrizione	Benennung Descripción	Description		Part N° Teil Nr. Code N° Cod. N° Referencia T7DD	Part N° Teil Nr. Code N° Cod. N° Referencia T7DDS	Qty Stück Qté Q.tà Cant.
17	Retaining ring <i>Anello elastico</i>	Sicherungsring <i>Anillo de retención</i>	Circlips			356.32283	1
18	Screw <i>Vite</i>	Schraube <i>Tornille</i>	Vis	AB		317.10300.3	4
19	Dowel pin <i>Spina</i>	Zentrierstift <i>Pasador</i>	Goupille	AB		323.82004	2
20	Dowel pin <i>Spina</i>	Zentrierstift <i>Pasador</i>	Goupille	AB		324.21612	4
21	Sq. section seal <i>Guarnizione</i>	Dichtring <i>Junta seccion cuadrada</i>	Joint section carrée	ABC		671.10159	2
22	Back-up ring <i>Anello anti-estrusione</i>	Stützring <i>Anillo</i>	Bague anti-extrusion	ABC		618.00011.3	2
23	Sq. section seal <i>Guarnizione</i>	Dichtring <i>Junta seccion cuadrada</i>	Joint section carrée	ABC		691.10244	2
24	Sq. section seal <i>Guarnizione</i>	Dichtring <i>Junta seccion cuadrada</i>	Joint section carrée	ABC		691.10232	2
25	Screw <i>Vite</i>	Schraube <i>Tornille</i>	Vis			361.14324.3	8
	REPAIR KIT KIT DI RICAMBIO	AUSTAUSCH-BAUGRUPPEN CUNJUNTO REPARACION	POCHETTES RECHANGES				
A	Cart. and plate ass'y B14 C.W. (P1) <i>Ins. cart. B14 oraria (P1)</i>	Pumpeneinheit B14 Rechtslauf (P1) <i>Conjunto cart. y platos B14 giro d. (P1)</i>	Cart. et plaque ass. B14 rot. d. (P1)			S24.76963	1
A	Cart. and plate ass'y B14 C.C.W. (P1) <i>Ins. cart. B14 antioraria (P1)</i>	Pumpeneinheit B14 Linkslauf (P1) <i>Conjunto cart. y platos B14 giro i. (P1)</i>	Cart. et plaque ass. B14 rot. g. (P1)			S24.76964	1
A	Cart. and plate ass'y B17 C.W. (P1) <i>Ins. cart. B17 oraria (P1)</i>	Pumpeneinheit B17 Rechtslauf (P1) <i>Conjunto cart. y platos B17 giro d. (P1)</i>	Cart. et plaque ass. B17 rot. d. (P1)			S24.76965	1
A	Cart. and plate ass'y B17 C.C.W. (P1) <i>Ins. cart. B17 antioraria (P1)</i>	Pumpeneinheit B17 Linkslauf (P1) <i>Conjunto cart. y platos B17 giro i. (P1)</i>	Cart. et plaque ass. B17 rot. g. (P1)			S24.76966	1
A	Cart. and plate ass'y B20 C.W. (P1) <i>Ins. cart. B20 oraria (P1)</i>	Pumpeneinheit B20 Rechtslauf (P1) <i>Conjunto cart. y platos B20 giro d. (P1)</i>	Cart. et plaque ass. B20 rot. d. (P1)			S24.76967	1
A	Cart. and plate ass'y B20 C.C.W. (P1) <i>Ins. cart. B20 antioraria (P1)</i>	Pumpeneinheit B20 Linkslauf (P1) <i>Conjunto cart. y platos B20 giro i. (P1)</i>	Cart. et plaque ass. B20 rot. g. (P1)			S24.76968	1
A	Cart. and plate ass'y B22 C.W. (P1) <i>Ins. cart. B22 oraria (P1)</i>	Pumpeneinheit B22 Rechtslauf (P1) <i>Conjunto cart. y platos B22 giro d. (P1)</i>	Cart. et plaque ass. B22 rot. d. (P1)			S24.76969	1
A	Cart. and plate ass'y B22 C.C.W. (P1) <i>Ins. cart. B22 antioraria (P1)</i>	Pumpeneinheit B22 Linkslauf (P1) <i>Conjunto cart. y platos B22 giro i. (P1)</i>	Cart. et plaque ass. B22 rot. g. (P1)			S24.76970	1
A	Cart. and plate ass'y B24 C.W. (P1) <i>Ins. cart. B24 oraria (P1)</i>	Pumpeneinheit B24 Rechtslauf (P1) <i>Conjunto cart. y platos B24 giro d. (P1)</i>	Cart. et plaque ass. B24 rot. d. (P1)			S24.76971	1
A	Cart. and plate ass'y B24 C.C.W. (P1) <i>Ins. cart. B24 antioraria (P1)</i>	Pumpeneinheit B24 Linkslauf (P1) <i>Conjunto cart. y platos B24 giro i. (P1)</i>	Cart. et plaque ass. B24 rot. g. (P1)			S24.76972	1
A	Cart. and plate ass'y B28 C.W. (P1) <i>Ins. cart. B28 oraria (P1)</i>	Pumpeneinheit B28 Rechtslauf (P1) <i>Conjunto cart. y platos B28 giro d. (P1)</i>	Cart. et plaque ass. B28 rot. d. (P1)			S24.76973	1
A	Cart. and plate ass'y B28 C.C.W. (P1) <i>Ins. cart. B28 antioraria (P1)</i>	Pumpeneinheit B28 Linkslauf (P1) <i>Conjunto cart. y platos B28 giro i. (P1)</i>	Cart. et plaque ass. B28 rot. g. (P1)			S24.76974	1
A	Cart. and plate ass'y B31 C.W. (P1) <i>Ins. cart. B31 oraria (P1)</i>	Pumpeneinheit B31 Rechtslauf (P1) <i>Conjunto cart. y platos B31 giro d. (P1)</i>	Cart. et plaque ass. B31 rot. d. (P1)			S24.76975	1

Item Pos. Réf. Pos. Pos.	Description Descrizione	Benennung Descripcion	Description	Part N° Teil Nr. Code N° Cod. N° Referencia T7DD	Part N° Teil Nr. Code N° Cod. N° Referencia T7DDS	Qty Stück Qté Q.tà Cant.
A	Cart. and plate ass'y B31 C.C.W. (P1) <i>Ins. cart. B31 antioraria (P1)</i>	Pumpeneinheit B31 Linkslauf (P1) <i>Conjunto cart. y platos B31 giro i. (P1)</i>	Cart. et plaque ass. B31 rot. g. (P1)	S24.76976		1
A	Cart. and plate ass'y B35 C.W. (P1) <i>Ins. cart. B35 oraria (P1)</i>	Pumpeneinheit B35 Rechtslauf (P1) <i>Conjunto cart. y platos B35 giro d. (P1)</i>	Cart. et plaque ass. B35 rot. d. (P1)	S24.76977		1
A	Cart. and plate ass'y B35 C.C.W. (P1) <i>Ins. cart. B35 antioraria (P1)</i>	Pumpeneinheit B35 Linkslauf (P1) <i>Conjunto cart. y platos B35 giro i. (P1)</i>	Cart. et plaque ass. B35 rot. g. (P1)	S24.76978		1
A	Cart. and plate ass'y B38 C.W. (P1) <i>Ins. cart. B38 oraria (P1)</i>	Pumpeneinheit B38 Rechtslauf (P1) <i>Conjunto cart. y platos B38 giro d. (P1)</i>	Cart. et plaque ass. B38 rot. d. (P1)	S24.76979		1
A	Cart. and plate ass'y B38 C.C.W. (P1) <i>Ins. cart. B38 antioraria (P1)</i>	Pumpeneinheit B38 Linkslauf (P1) <i>Conjunto cart. y platos B38 giro i. (P1)</i>	Cart. et plaque ass. B38 rot. g. (P1)	S24.76980		1
A	Cart. and plate ass'y B42 C.W. (P1) <i>Ins. cart. B42 oraria (P1)</i>	Pumpeneinheit B42 Rechtslauf (P1) <i>Conjunto cart. y platos B42 giro d. (P1)</i>	Cart. et plaque ass. B42 rot. d. (P1)	S24.76981		1
A	Cart. and plate ass'y B42 C.C.W. (P1) <i>Ins. cart. B42 antioraria (P1)</i>	Pumpeneinheit B42 Linkslauf (P1) <i>Conjunto cart. y platos B42 giro i. (P1)</i>	Cart. et plaque ass. B42 rot. g. (P1)	S24.76982		1
A	Cart. and plate ass'y 045 C.W. (P1) <i>Ins. cart. 045 oraria (P1)</i>	Pumpeneinheit 045 Rechtslauf (P1) <i>Conjunto cart. y platos 045 giro d. (P1)</i>	Cart. et plaque ass. 045 rot. d. (P1)	S24.10859		1
A	Cart. and plate ass'y 045 C.C.W. (P1) <i>Ins. cart. 045 antioraria (P1)</i>	Pumpeneinheit 045 Linkslauf (P1) <i>Conjunto cart. y platos 045 giro i. (P1)</i>	Cart. et plaque ass. 045 rot. g. (P1)	S24.10860		1
A	Cart. and plate ass'y 050 C.W. (P1) <i>Ins. cart. 050 oraria (P1)</i>	Pumpeneinheit 050 Rechtslauf (P1) <i>Conjunto cart. y platos 050 giro d. (P1)</i>	Cart. et plaque ass. 050 rot. d. (P1)	S24.40236		1
A	Cart. and plate ass'y 050 C.C.W. (P1) <i>Ins. cart. 050 antioraria (P1)</i>	Pumpeneinheit 050 Linkslauf (P1) <i>Conjunto cart. y platos 050 giro i. (P1)</i>	Cart. et plaque ass. 050 rot. g. (P1)	S24.40237		1
B	Cart. and plate ass'y B14 C.W. (P2) <i>Ins. cart. B14 oraria (P2)</i>	Pumpeneinheit B14 Rechtslauf (P2) <i>Conjunto cart. y platos B14 giro d. (P2)</i>	Cart. et plaque ass. B14 rot. d. (P2)	S24.76983		1
B	Cart. and plate ass'y B14 C.C.W. (P2) <i>Ins. cart. B14 antioraria (P2)</i>	Pumpeneinheit B14 Linkslauf (P2) <i>Conjunto cart. y platos B14 giro i. (P2)</i>	Cart. et plaque ass. B14 rot. g. (P2)	S24.76984		1
B	Cart. and plate ass'y B17 C.W. (P2) <i>Ins. cart. B17 oraria (P2)</i>	Pumpeneinheit B17 Rechtslauf (P2) <i>Conjunto cart. y platos B17 giro d. (P2)</i>	Cart. et plaque ass. B17 rot. d. (P2)	S24.76985		1
B	Cart. and plate ass'y B17 C.C.W. (P2) <i>Ins. cart. B17 antioraria (P2)</i>	Pumpeneinheit B17 Linkslauf (P2) <i>Conjunto cart. y platos B17 giro i. (P2)</i>	Cart. et plaque ass. B17 rot. g. (P2)	S24.76986		1
B	Cart. and plate ass'y B20 C.W. (P2) <i>Ins. cart. B20 oraria (P2)</i>	Pumpeneinheit B20 Rechtslauf (P2) <i>Conjunto cart. y platos B20 giro d. (P2)</i>	Cart. et plaque ass. B20 rot. d. (P2)	S24.76987		1
B	Cart. and plate ass'y B20 C.C.W. (P2) <i>Ins. cart. B20 antioraria (P2)</i>	Pumpeneinheit B20 Linkslauf (P2) <i>Conjunto cart. y platos B20 giro i. (P2)</i>	Cart. et plaque ass. B20 rot. g. (P2)	S24.76988		1
B	Cart. and plate ass'y B22 C.W. (P2) <i>Ins. cart. B22 oraria (P2)</i>	Pumpeneinheit B22 Rechtslauf (P2) <i>Conjunto cart. y platos B22 giro d. (P2)</i>	Cart. et plaque ass. B22 rot. d. (P2)	S24.76989		1
B	Cart. and plate ass'y B22 C.C.W. (P2) <i>Ins. cart. B22 antioraria (P2)</i>	Pumpeneinheit B22 Linkslauf (P2) <i>Conjunto cart. y platos B22 giro i. (P2)</i>	Cart. et plaque ass. B22 rot. g. (P2)	S24.76990		1
B	Cart. and plate ass'y B24 C.W. (P2) <i>Ins. cart. B24 oraria (P2)</i>	Pumpeneinheit B24 Rechtslauf (P2) <i>Conjunto cart. y platos B24 giro d. (P2)</i>	Cart. et plaque ass. B24 rot. d. (P2)	S24.76991		1
B	Cart. and plate ass'y B24 C.C.W. (P2) <i>Ins. cart. B24 antioraria (P2)</i>	Pumpeneinheit B24 Linkslauf (P2) <i>Conjunto cart. y platos B24 giro i. (P2)</i>	Cart. et plaque ass. B24 rot. g. (P2)	S24.76992		1
B	Cart. and plate ass'y B28 C.W. (P2) <i>Ins. cart. B28 oraria (P2)</i>	Pumpeneinheit B28 Rechtslauf (P2) <i>Conjunto cart. y platos B28 giro d. (P2)</i>	Cart. et plaque ass. B28 rot. d. (P2)	S24.76993		1
B	Cart. and plate ass'y B28 C.C.W. (P2) <i>Ins. cart. B28 antioraria (P2)</i>	Pumpeneinheit B28 Linkslauf (P2) <i>Conjunto cart. y platos B28 giro i. (P2)</i>	Cart. et plaque ass. B28 rot. g. (P2)	S24.76994		1
B	Cart. and plate ass'y B31 C.W. (P2) <i>Ins. cart. B31 oraria (P2)</i>	Pumpeneinheit B31 Rechtslauf (P2) <i>Conjunto cart. y platos B31 giro d. (P2)</i>	Cart. et plaque ass. B31 rot. d. (P2)	S2476995		1
B	Cart. and plate ass'y B31 C.C.W. (P2) <i>Ins. cart. B31 antioraria (P2)</i>	Pumpeneinheit B31 Linkslauf (P2) <i>Conjunto cart. y platos B31 giro i. (P2)</i>	Cart. et plaque ass. B31 rot. g. (P2)	S24.46996		1

Item Pos. Réf. Pos. Pos.	Description Descrizione	Benennung Descripcion	Description	Part N° Teil Nr. Code N° Cod. N° Referencia T7DD	Part N° Teil Nr. Code N° Cod. N° Referencia T7DDS	Qty Stück Qté Q.tà Cant.
B	Cart. and plate ass'y B35 C.W. (P2) <i>Ins. cart. B35 oraria (P2)</i>	Pumpeneinheit B35 Rechtslauf (P2) <i>Conjunto cart. y platos B35 giro d. (P2)</i>	Cart. et plaque ass. B35 rot. d. (P2)	S24.76997		1
B	Cart. and plate ass'y B35 C.C.W. (P2) <i>Ins. cart. B35 antioraria (P2)</i>	Pumpeneinheit B35 Linkslauf (P2) <i>Conjunto cart. y platos B35 giro i. (P2)</i>	Cart. et plaque ass. B35 rot. g. (P2)	S24.76998		1
B	Cart. and plate ass'y B38 C.W. (P2) <i>Ins. cart. B38 oraria (P2)</i>	Pumpeneinheit B38 Rechtslauf (P2) <i>Conjunto cart. y platos B38 giro d. (P2)</i>	Cart. et plaque ass. B38 rot. d. (P2)	S24.76999		1
B	Cart. and plate ass'y B38 C.C.W. (P2) <i>Ins. cart. B38 antioraria (P2)</i>	Pumpeneinheit B38 Linkslauf (P2) <i>Conjunto cart. y platos B38 giro i. (P2)</i>	Cart. et plaque ass. B38 rot. g. (P2)	S24.77000		1
B	Cart. and plate ass'y B42 C.W. (P2) <i>Ins. cart. B42 oraria (P2)</i>	Pumpeneinheit B42 Rechtslauf (P2) <i>Conjunto cart. y platos B42 giro d. (P2)</i>	Cart. et plaque ass. B42 rot. d. (P2)	S24.77001		1
B	Cart. and plate ass'y B42 C.C.W. (P2) <i>Ins. cart. B42 antioraria (P2)</i>	Pumpeneinheit B42 Linkslauf (P2) <i>Conjunto cart. y platos B42 giro i. (P2)</i>	Cart. et plaque ass. B42 rot. g. (P2)	S24.77002		1
B	Cart. and plate ass'y 045 C.W. (P2) <i>Ins. cart. 045 oraria (P2)</i>	Pumpeneinheit 045 Rechtslauf (P2) <i>Conjunto cart. y platos 045 giro d. (P2)</i>	Cart. et plaque ass. 045 rot. d. (P2)	S24.58176		1
B	Cart. and plate ass'y 045 C.C.W. (P2) <i>Ins. cart. 045 antioraria (P2)</i>	Pumpeneinheit 045 Linkslauf (P2) <i>Conjunto cart. y platos 045 giro i. (P2)</i>	Cart. et plaque ass. 045 rot. g. (P2)	S24.58177		1
B	Cart. and plate ass'y 050 C.W. (P2) <i>Ins. cart. 050 oraria (P2)</i>	Pumpeneinheit 050 Rechtslauf (P2) <i>Conjunto cart. y platos 050 giro d. (P2)</i>	Cart. et plaque ass. 050 rot. d. (P2)	S24.58178		1
B	Cart. and plate ass'y 050 C.C.W. (P2) <i>Ins. cart. 050 antioraria (P2)</i>	Pumpeneinheit 050 Linkslauf (P2) <i>Conjunto cart. y platos 050 giro i. (P2)</i>	Cart. et plaque ass. 050 rot. g. (P2)	S24.58195		1
C	Seal kit (S1 - 0,7 bar) <i>Serie guarnizioni (S1 - 0,7 bar)</i>	Dichtringsatz (S1 - 0,7 bar) <i>Juego de juntas (S1 - 0,7 bar)</i>	Pochette de joint (S1 - 0,7 bar)	S24.72351		1
C	Seal kit (S4 - 7 bar) <i>Serie guarnizioni (S4 - 7 bar)</i>	Dichtringsatz (S4 - 7 bar) <i>Juego de juntas (S4 - 7 bar)</i>	Pochette de joint (S4 - 7 bar)	S24.72351.4		1
C	Seal kit (S5 - 7 bar) <i>Serie guarnizioni (S5 - 7 bar)</i>	Dichtringsatz (S5 - 7 bar) <i>Juego de juntas (S5 - 7 bar)</i>	Pochette de joint (S5 - 7 bar)	S24.72351.5		1
D	Shaft and bearing ass'y (code 1) <i>Ins. albero (codice 1)</i>	Baugruppe (Welle u. Lager) (Typ 1) <i>Conjunto eje cojinete (codigo 1)</i>	Arbre et roulement ass. (code 1)		S24.72352	1
E	Shaft and bearing ass'y (code 2) <i>Ins. albero (codice 2)</i>	Baugruppe (Welle u. Lager) (Typ 2) <i>Conjunto eje cojinete (codigo 2)</i>	Arbre et roulement ass. (code 2)		S24.72353	1
F	Shaft and bearing ass'y (code 3) <i>Ins. albero (codice 3)</i>	Baugruppe (Welle u. Lager) (Typ 3) <i>Conjunto eje cojinete (codigo 3)</i>	Arbre et roulement ass. (code 3)		S24.72354	1
G	Shaft and bearing ass'y (code 4) <i>Ins. albero (codice 4)</i>	Baugruppe (Welle u. Lager) (Typ 4) <i>Conjunto eje cojinete (codigo 4)</i>	Arbre et roulement ass. (code 4)		S24.72355	1
H	Shaft and bearing ass'y (code 5) <i>Ins. albero (codice 5)</i>	Baugruppe (Welle u. Lager) (Typ 5) <i>Conjunto eje cojinete (codigo 5)</i>	Arbre et roulement ass. (code 5)	S24.77003		1
I	Port plate rear ass'y (Except cam ring 045 - 050) (P2) <i>Ins. piatto distributore post. (Eccetto anello camma 045 - 050) (P2)</i>	Steuerplatte (außer Hubringe 045 - 050) (P2) <i>Conj. plato dist. trasero (Excepto los aros 045 - 050) (P2)</i>	Plaque arr. ass. (Excepté cames 045 - 050) (P2)	S24.76332		1
J	Port plate rear ass'y C.C.W. (Only cam ring 045 - 050) (P2) <i>Ins. piatto dist. post. antioraria (Solo anello camma 045 - 050) (P2)</i>	Steuerplatte Linkslauf (nur Hubringe 045 - 050) (P2) <i>Conj. plato dist. trasero giro I (Solo los aros 045 - 050) (P2)</i>	Plaque arr. ass. rot. g. (Seulement cames 045 - 050) (P2)	S24.63709		1
K	Port plate rear ass'y C.W. (Only cam ring 045 - 050) (P2) <i>Ins. piatto dist. post. oraria (Solo anello camma 045 - 050) (P2)</i>	Steuerplatte Rechtslauf (nur Hubringe 045 - 050) (P2) <i>Conj. plato dist. trasero giro D (Solo los aros 045 - 050) (P2)</i>	Plaque arr. ass. rot. d. (Seulement cames 045 - 050) (P2)	S24.63710		1
L	Port plate rear ass'y (Except cam ring 045 - 050) (P1) <i>Ins. piatto distributore post. (Eccetto anello camma 045 - 050) (P1)</i>	Steuerplatte (außer Hubringe 045 - 050) (P1) <i>Conj. plato dist. trasero (Excepto los aros 045 - 050) (P1)</i>	Plaque arr. ass. (Excepté cames 045 - 050) (P1)	S24.76916		1
M	Port plate rear ass'y C.C.W. (Only cam ring 045 - 050) (P1) <i>Ins. piatto dist. post. antioraria (Solo anello camma 045 - 050) (P1)</i>	Steuerplatte Linkslauf (nur Hubringe 045 - 050) (P1) <i>Conj. plato dist. trasero giro I (Solo los aros 045 - 050) (P1)</i>	Plaque arr. ass. rot. g. (Seulement cames 045 - 050) (P1)	S24.63951		1
N	Port plate rear ass'y C.W. (Only cam ring 045 - 050) (P1) <i>Ins. piatto dist. post. oraria (Solo anello camma 045 - 050) (P1)</i>	Steuerplatte Rechtslauf (nur Hubringe 045 - 050) (P1) <i>Conj. plato dist. trasero giro D (Solo los aros 045 - 050) (P1)</i>	Plaque arr. ass. rot. d. (Seulement cames 045 - 050) (P1)	S24.63950		1

Model Code

Typenschlüssel

Désignation - type

Model number

Typenbezeichnung :

Numéro du modèle :

T7DD / T7DDS . - B42 - B22 - 1 R 00 - A 1 M0 - ..

T7DD series - ISO 4 bolts 3019-2
125 B4 HW
T7DDS series - SAE C - 6 bolts
Mounting flange J744

Baureihe T7DD - ISO 4-Loch 3019-2
125 B4 HW
Baureihe T7DDS - SAE C 6-Loch
Montageflansch, J744

Série T7DD - ISO 4 trous 3019-2
125 B4 HW
Série T7DDS - SAE C 6 trous
Bride de montage J744

One letter can be added to specify special parts in series

Optionen

Une lettre peut être ajoutée pour spécifier les pièces spéciales dans la série.

Cam ring P1 & P2

(Volumetric displacement) (ml/rev.)
B14 = 44,0
B17 = 55,0
B20 = 66,0
B22 = 70,3

Hubring P1 & P2

(Geometrisches Fördervolumen) (cm³/U)
B24 = 81,1
B28 = 90,0
B31 = 99,2
B35 = 113,4

Came P1 & P2

(Cylindrée théorique) (cm³/tr)
B38 = 120,6
B42 = 137,5
045 = 145,7
050 = 158,0

Type of shaft T7DDS

1 = keyed (SAE C)
2 = keyed (SAE CC)
3 = splined 12/24 (SAE C)
4 = splined 16/32 (SAE BB)

Art der Welle T7DDS

1 = Paßfederwelle (SAE C)
2 = Paßfederwelle (SAE CC)
3 = Vielkeilwelle 12/24 (SAE C)
4 = Vielkeilwelle 16/32 (SAE BB)

Type d'arbre T7DDS

1 = à clavette (SAE C)
2 = à clavette (SAE CC)
3 = à cannelures 12/24 (SAE C)
4 = à cannelures 16/32 (SAE BB)

Type of shaft T7DD & T7DDS

5 = keyed (ISO 3019-2 - G32M)

Art der Welle T7DD & T7DDS

5 = Paßfederwelle (ISO 3019-2 - G32M)

Type d'arbre T7DD & T7DDS

5 = à clavette (ISO 3019-2 - G32M)

Direction of rotation

R = Clockwise
L = Counter-clockwise

Drehrichtung

R = Rechtslauf
L = Linkslauf

Sens de rotation

R = à droite
L = à gauche

Porting combination

00 = standard

Lage der Anschlüsse

00 = standard

Combinaison des orifices

00 = standard

Design letter

Ausführungsbuchstabe

Conception

Seal class

1 = S1 - BUNA N
4 = S4 - EPDM
5 = S5 - VITON

Dichtungsklasse

1 = S1 - BUNA N
4 = S4 - EPDM
5 = S5 - VITON

Classe de joint

1 = S1 - BUNA N
4 = S4 - EPDM
5 = S5 - VITON

Mounting w/connection variables

4 bolts SAE flanges (J518)

	P1 & P2 = 1"1/4 - S = 4"	
	UNC	Metric
T7DD		M0
T7DDS	00	M0

Gehäuse-Anschlußgröße

SAE-Vierlochflansch (J518)

	P1 & P2 = 1"1/4 - S = 4"	
	UNC	Metrisches
T7DD		M0
T7DDS	00	M0

Option sur orifices

Bride SAE 4 trous (J518)

	P1 & P2 = 1"1/4 - S = 4"	
	UNC	Métrique
T7DD		M0
T7DDS	00	M0

Modifications

Modifikationen

Modifications

Designazione

Clave de designación

Sigla :

Serie T7DD - ISO 4 fori 3019-2
125 B4 HW
Serie T7DDS - SAE C 6 fori
Flangia di montaggio J744

Una lettera può essere aggiunta per specificare parti speciali nella serie

Tipo di cartuccia P1 & P2

(Cilindrata) (ml/giro)
B14 = 44,0
B17 = 55,0
B20 = 66,0
B22 = 70,3
B24 = 81,1
B28 = 90,0

Tipo di albero T7DDS

1 = a chiavetta (SAE C)
2 = a chiavetta (SAE CC)
3 = scanalato 12/24 (SAE C)
4 = scanalato 16/32 (SAE BB)

Tipo di albero T7DD & T7DDS

5 = a chiavetta (ISO 3019-2 - G32M)

Senso di rotazione

R =orario
L = Antiorario

Orientamento delle bocche

00 = standard

Diseño

Tipo di guarnizioni

1 = S1 - BUNA N
4 = S4 - EPDM
5 = S5 - VITON

Dimensioni delle bocche

Flangia SAE 4 drenaggio (J518)

	P1 & P2 = 1"1/4 - S = 4"	
	UNC	Metrica
T7DD		M0
T7DDS	00	M0

Modifiche

Referencia modelo :

Serie T7DD - ISO 4 taladros 3019-2
125 B4 HW
Serie T7DDS - SAE C 6 taladros
Brida de montaje J744

Una letra puede ser añadida para especificar piezas especiales en la serie

Aro volumetrico P1 & P2

(Cilindrada) (ml/rev)
B31 = 99,2
B35 = 113,4
B38 = 120,6
B42 = 137,5
045 = 145,7
050 = 158,0

Tipo de eje T7DDS

1 = chaveteado (SAE C)
2 = chaveteado (SAE CC)
3 = estriado 12/24 (SAE C)
4 = estriado 16/32 (SAE BB)

Tipo de eje T7DD & T7DDS

5 = chaveteado (ISO 3019-2 - G32M)

Sentido de giro

R = Derecha
L = Izquierda

Posición de bocas

00 = estándar

Letra de diseño

Clase de juntas

1 = S1 - BUNA N
4 = S4 - EPDM
5 = S5 - VITON

Opciones de las bocas

Brida SAE 4 taladros (J518)

	P1 & P2 = 1"1/4 - S = 4"	
	UNC	Metrica
T7DD		M0
T7DDS	00	M0

Modificaciones

T7DD / T7DDS - **B42** - **B22** - **1** **R** **00** - **A** **1** **M0** - ..