

B548 Filter / Regulator – Miniature

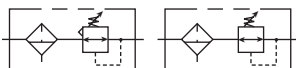

Features

- Excellent Water Removal Efficiency
- Unbalanced Poppet Standard
- Solid Control Piston for Extended Life
- Space Saving Package Offers Both Filter and Regulator Features in One Integral Unit
- Non-rising Adjustment Knob
- High Flow: 12 SCFM[§]

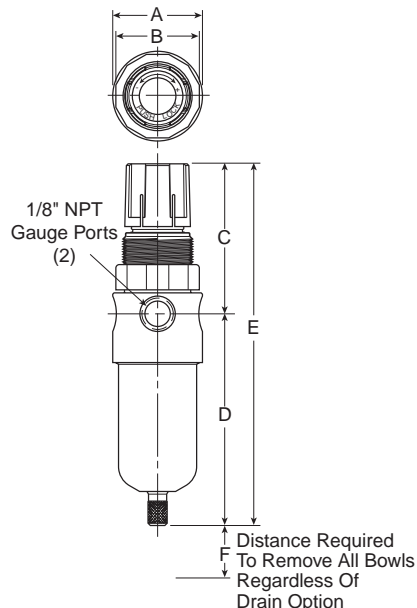

C

| Port Size | NPT | |
|--------------------------------|--------------------|--|
| | Manual Twist Drain | |
| Poly Bowl [†] | | |
| 1/8" | B548-01AHC | |
| 1/4" | B548-02AHC | |
| Metal Bowl without Sight Gauge | | |
| 1/8" | B548-01DHC | |
| 1/4" | B548-02DHC | |

| B548 Filter / Regulator Dimensions | | |
|------------------------------------|----------------|----------------|
| A | B | C |
| 1.55 (39.2) | 4.44 (36.5) | 2.58 (65.6) |
| D | E | F |
| 6.23 (158.2) | 3.81 (96.7) | 0.86 (21.9) |

Inches (mm)
[†] With Auto Drain

Bold Items are Most Popular.

For other models refer to ordering information below.

NOTE: 1.218 Dia. (31mm) hole required for panel mounting.

[‡] For polycarbonate bowl see Caution on page C2.

[§] SCFM = Standard cubic feet per minute at 100 PSIG inlet, 75 PSIG no flow secondary setting and 25% pressure drop.

Ordering Information



| | | | | | | |
|--|--|---|---|--|--|---|
| Port Threads — NPT G BSPP | Port Size 01 1/8 Inch 02 1/4 Inch | Bowl A Polycarbonate Bowl D Metal without Sight Gauge | Elements G 5 Micron H 20 Micron | Reduced Pressure Range A 0-25 PSIG B 0-60 PSIG C 0-125 PSIG | Options G Gauge K Non-Relieving P Panel Mount (Plastic) S Automatic Pulse Drain T Tamperproof U Semi-Auto Drain X64 Fluorocarbon O-rings & Diaphragm X33* Polyurethane Bowl | Engineering Change Designator Will be entered at factory. |
|--|--|---|---|--|--|---|

BOLD ITEMS ARE MOST POPULAR.

* Add .65" to overall length.



Technical Information

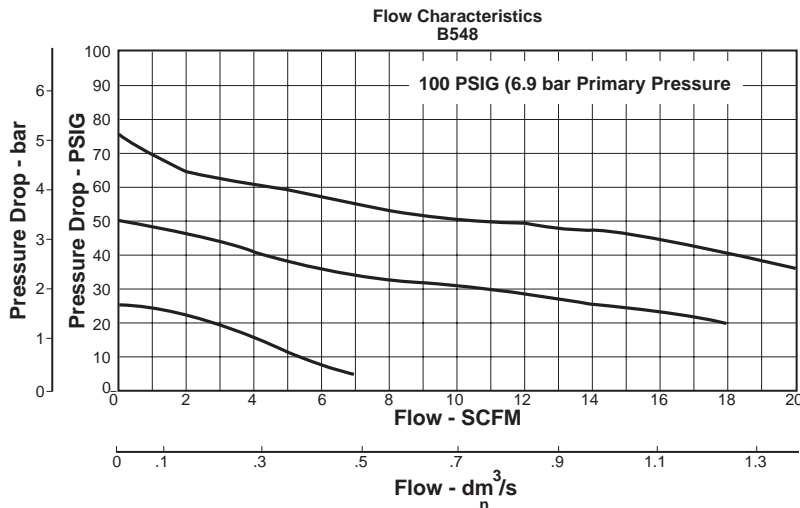

⚠ WARNING

**Product rupture can cause serious injury.
 Do not connect regulator to bottled gas.
 Do not exceed maximum primary pressure rating.**

⚠ CAUTION:

REGULATOR PRESSURE ADJUSTMENT – The working range of knob adjustment is designed to permit outlet pressures within their full range. Pressure adjustment beyond this range is also possible because the knob is not a limiting device. This is a common characteristic of most industrial regulators, and limiting devices may be obtained only by special design. For best performance, regulated pressure should always be set by increasing the pressure up to the desired setting.

B548 Filter / Regulator Kits & Accessories

- Bowl Kits –**
 - Zinc (D)..... BK505Y
 - Zinc with Automatic Pulse Drain (D)..... BK505SY
 - Polycarbonate (A)..... BK504Y
 - Polycarbonate with Automatic Pulse Drain (A)..... BK504SY
- Cage Kits (All).....** CKR364Y
- Drain Kits –**
 - Automatic Pulse Drain
(Maximum Pressure = 175 PSIG) RK504SY
 - Semi-Automatic “Overnight” Drain SA602A7
(Drains automatically under zero pressure)
- Filter Element Kits –**
 - 20 Micron (All) EK504Y
 - 5 Micron (All) EK504VY
- Gauges –**
 - 1-1/2" Dial Size, 1/8" Back Connection
0 to 60 PSIG (0 to 400 kPa) K4515N18060
 - 1-1/2" Dial Size, 1/8" Back Connection
0 to 160 PSIG (0 to 1100 kPa) K4515N18160
- Mounting Bracket Kit (Includes Plastic Panel Nut)** SA161X57
- Panel Mount Nut –**
 - Plastic..... R05X51-P
 - Aluminum..... R05X51-A
- Repair Kits –**
 - Non-Relieving Diaphragm, Valve Assembly (All) RK548Y
 - Relieving Diaphragm, Valve Assembly (All)..... RK549Y
- Specifications**
- Bowl Capacity** 1 Ounce

- Gauge Ports (2)** 1/8 Inch
- Maximum Pressure –**
 - Zinc Bowl (D) 0 to 300 PSIG
 - Polycarbonate Bowl (A) 0 to 150 PSIG
- Port Threads** 1/4 Inch
- Reduced Pressure Range –**
 - 0 to 25 PSIG (0 to 1.7 bar) (A)
 - 0 to 60 PSIG (0 to 4.1 bar) (B)
 - 2 to 125 PSIG (0.15 to 8.5 bar) (C)
- Temperature Rating** 40°F to 125°F (4.4°C to 52°C)
- Weight –**
 - Zinc Bowl (D) 0.6 lb. (0.27 kg) / Unit
12 lb. (5.44 kg) / 24-Unit Master Pack
 - Polycarbonate Bowl (A) 0.3 lb. (0.14 kg) / Unit
6 lb. (2.72 kg) / 24-Unit Master Pack

Materials of Construction

- Adjusting Knob** Acetal
- Body** Aluminum
- Bowls –**
 - Polycarbonate (A)..... Polycarbonate
 - Metal (D)..... Zinc
Zinc with Automatic Pulse Drain
- Elastomers** Buna N
- Filter Element** Sintered Polypropylene
- Filter Retainer, Vane Plate** Acetal
- Innervalve, Diaphragm, Button, Drain** Brass

