

## Controller Flags & Parameters

Flag	Number	Parameter	Number
<b>Control Flags</b>			
Start Network	16640	EPL Network Control	
Reset Network	16641	Number of CNs (default 1; range 0–15) <sup>†</sup>	P37376
<b>Status Flags</b>			
EPL Controller Installed	16648	Node ID EPLD0 (default 1; range 1–99) <sup>†</sup>	P37632*
Network Operational	16649	Drive Mode EPLD0	P37634*
Network Start Failed	16650	TCP/IP Port Number EPLD0	P37635*
EPL Node Failure	16651	<b>EPL Network Status</b>	
EPLD Stream OPEN	16652	Network State	P37384
EPLD Stream Disconnected	16653	Non-Operating Nodes Bit Reports	P37385
EPL Drive(s) Enabled	16654	EPL Operation Error Code (0 = no error)	P37386
Insufficient Period	16655	EPLD object OPENed (-1 = none)	P37387
Starting Network	16656	OPENed EPLD Device Number	P37388
Resetting Network	16657	Operational Duration in Seconds	P37389
Opening EPLD Stream	16660		

<sup>†</sup> Set by user  
\*For higher numbered EPLDs, work from EPLD0 and add n x 16 to each parameter number

## Compliance

UL, cUL Recognized Component, 508c



Product Type . . . . . Aries AR-04PE, -08PE, and -13PE Drives  
ACR9030 and ACR9040 Controllers

The above product complies with the requirements of directives EMC Directive 89/336/EEC, Low Voltage Directive 73/23/EEC, and CE Marking Directive 93/68/EEC, provided the installation requirements described in the *Aries EPL Hardware Installation Guide* are met, and there are no special requirements of the installation and operating environment so that the application may be considered typical.

The above equipment conforms with the protection requirements of Council Directive 89/336/EEC as amended by Directive 92/31/EEC on the approximation of the laws of the Member States relating to Electromagnetic Compatibility when installed, operated, and maintained as intended. Also, the above equipment conforms with the requirements of Council Directive 73/23/EEC (Low Voltage Directive) as amended by Directive 93/68/EEC (CE Marking Directive), when installed, operated, and maintained as intended.

In accordance with IEC 61800-3:1997 (adjustable-speed electrical power drive systems) this product is of the restricted sales distribution class which meets the needs of an industrial environment when installed as directed. However, further measures may need to be taken for use of the product in a domestic environment.

The installation requirements are detailed in the Information supplied with the equipment. The equipment is sold only to competent system builders.



## Safety Warning!



High-performance motion control equipment is capable of producing rapid movement and very high forces. Unexpected motion may occur especially during the development of controller programs. KEEP WELL CLEAR of any machinery driven by servo motors. Never touch any part of the equipment while it is in operation.

This product is sold as a motion control component to be installed in a complete system using good engineering practice. Care must be taken to ensure that the product is installed and used in a safe manner according to local safety laws and regulations. In particular, the product must be positioned so that no part is accessible while power may be applied.

This and other information from Parker Hannifin Corporation, its subsidiaries, and authorized distributors provides product or system options for further investigation by users having technical expertise. Before you select or use any product or system, it is important that you analyze all aspects of your application and review the information concerning the product in the current product catalog. The user, through its own analysis and testing, is solely responsible for making the final selection of the system and components and assuring that all performance, safety, and warning requirements of the application are met.

If the equipment is used in a manner that does not conform to the instructions given in this user guide, then the protection provided by the equipment may be impaired.

# ETHERNET Powerlink

## Quick Reference Guide

Aries AR-04PE, -08PE, and -13PE Servo Drives  
ACR9030 and ACR9040 Controllers

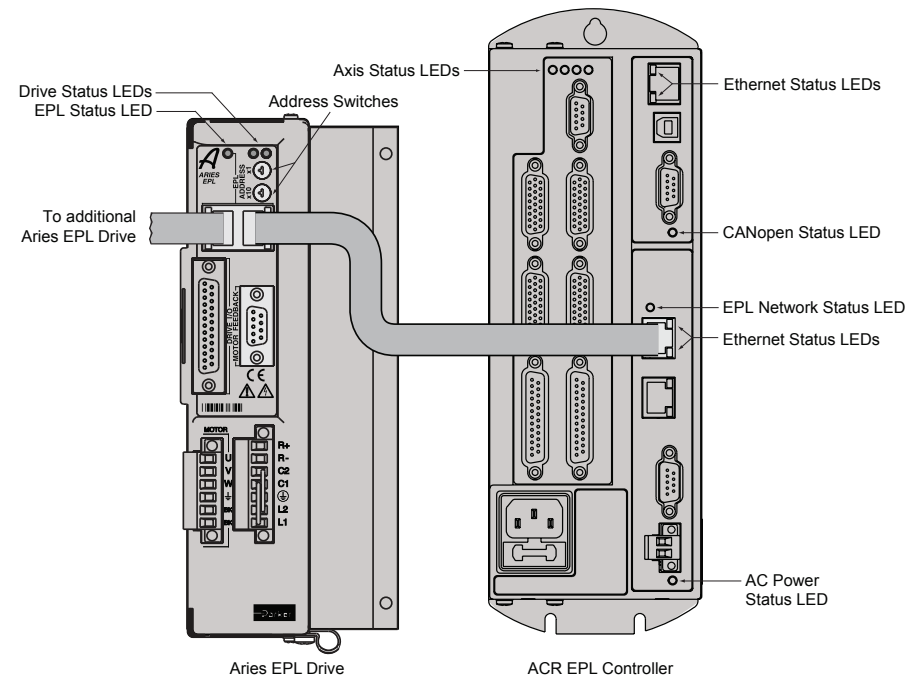

Electromechanical Division  
Parker Hannifin Corporation  
p/n 88-027023-01A

Effective: April 2007

<http://www.parkermotion.com>



### Drive I/O Connector

Signal	Pin
Input 0+	1
Input 0-	14
Input 1+	2
Input 1-	15
Input 2+	3
Input 2-	16
High-Speed Input 4+	4
High-Speed Input 4-	17
High-Speed Input 5+	5
High-Speed Input 5-	18
High-Speed Input 6+	6
High-Speed Input 6-	19
Input 3+	7
Input 3-	20
Not used	8
Not used	21
Output 0+	9
Output 0-	22
Output 1+	10
Output 1-	23
Output 2+	11
Output 2-	24
Output 3+	12
Output 3-	25
Not used	13

### EPL/Ethernet Connector

Signal	Pin
RX+	1
RX-	2
TX+	3
Not used	4
Not used	5
TX-	6
Not used	7
Not used	8

Ethernet Cable: Use braid over foil twisted-pair wiring (straight or crossover).

### Drive Output Power Connector

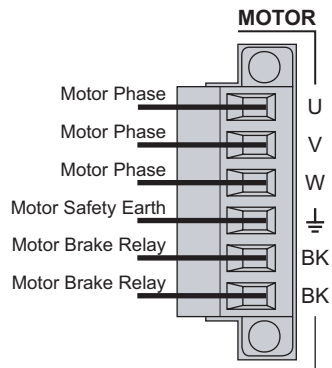

NOTE: A box surrounding the pins indicates a requirement for twisted-pair wiring.

### Drive Mains Power Connector

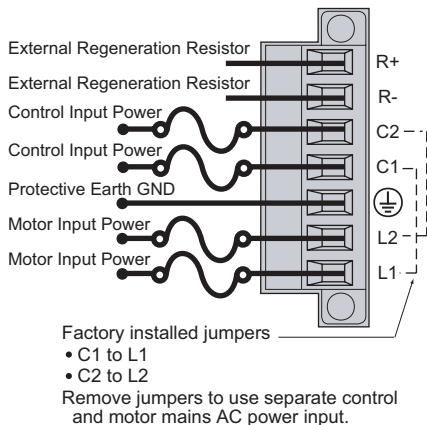

### Power Supply

120/240 VAC, 50-60Hz, single phase

### Fuse Information

Drive has no internal fuses. For safety, you must provide a fuse in each AC input line. See installation guide for complete information. Controller has one accessible fuse by the AC power connector. 250 VAC, 2.5A, TD, 5x20 mm. See installation guide for complete information.

### Motor Feedback Connector

Signal	Pin
ENC Z+/DATA+	1
ENC Z-/DATA-	2
DGND	3
+5 VDC (250mA max)	4
+5 VDC (250mA max)	5
DGND	6
ENC A-/SIN-	7
ENC A+/SIN+	8
Hall 1/SCLK+ *	9
Thermal+	10
Thermal-	15
ENC B-/COS-	11
ENC B+/COS+	12
Hall 2/SCLK- *	13
Hall 3	14

\*When using the SinCos protocol, pins 9 and 13 require twisted pair wiring.

# ETHERNET Powerlink

### Controller EPL Network Status LEDs

LED State	What it means
Off	Reset or not active—MN is off, initializing, or in reset state
Green	Basic Ethernet—Node operating as a basic Ethernet device, not EPL
Flickering	Pre-Operational 1—MN asking node status & configuring CNS; full EPL cycles not started
1 flash	Pre-Operational 2—Full EPL cycles started, node configuration not finished, data ignored
2 flashes	Ready to operate—CN has responded to request from MN; exchanged data ignored
3 flashes	Operational—Network exchanging valid data
Constant	Stopped—Network has stopped
Blinking	Indicates error state, obtained via P37386
Red	

### Controller Axis Status LEDs

LED State	What it means
Off	Axis disabled, no fault
Green	Axis enabled, no fault
Red	Axis fault; motion on axis disabled

NOTE: LED illuminates red whenever the drive fault input is activated.

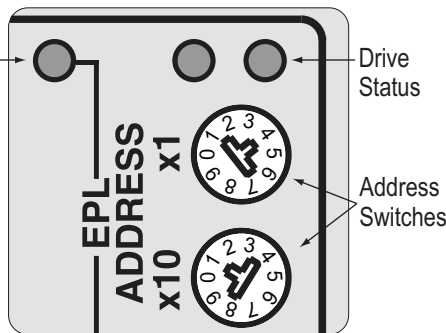

### Drive IP Address Switches

Set IP address/node ID with drive's rotary decimal switches. Ex: set 14 by rotating x10 switch to 1 and x1 switch to 4 (valid range is 01 to 99; 00 not valid). IP addresses are 192.168.100.xx, with xx being drive's switch setting.

### Warning!

- You must connect the drive's protective conductor terminal, marked with the earth symbol (⊕), to a reliable system Protective Earth.
- The drive's connector strip terminals are at hazardous voltages when power is applied to the drive, and up to several minutes after power is removed. Lower voltages may still be present for several minutes after power is removed.
- During normal operation, these high voltage terminals must not be accessible to the user.

### Controller CANopen Status LEDs

LED State	What it means
Green, flickering	AutoBaud detection is in progress, or LSS services are in progress (alternately flickering with red LED)
Green, 1 flash	Stopped—Device is in the stopped state
Green, blinking	Pre-operational—Device is in the pre-operational state
Green, constant	Operational—Device is in the operational state
Red, 1 flash	Warning Limit Reached—At least one of the error counters of the CAN controller has reached or exceeded the warning level (too many error frames)
Red, flickering	AutoBaud detection is in progress, or LSS services are in progress
Red, 2 flashes	A guard event (NMT-slave or NMT-master) or a heartbeat event (heartbeat consumer) has occurred
Red, 3 flashes	SYNC message has not been received within the configured communication cycle period time out (see Object Dictionary Entry 0x1006)
Red, constant	BUS off—CAN controller is bus off
Off	Reset—controller is executing a reset

See front cover for controller LED locations.

### Controller & Drive Ethernet Status LEDs

LED	State	What it means
Ethernet Link/Activity	Off	No Ethernet link detected
	Yellow	Ethernet link established; no activity
	Yellow, flashing	Ethernet link established and active
Ethernet Speed	Off	Ethernet 10Mbps
	Green	Ethernet 100Mbps

### Drive EPL Status LEDs

LED State	What it means
Off	Powering up, searching for Ethernet
Off/Green (alternating, 50 ms)	Standard Ethernet mode, no error
Red/Green (alternating, 50 ms)	Standard Ethernet mode, EPL error
Green, 1 flash	Waiting for configuration (followed by Start of Cycle frame)
Green, 2 flashes	Waiting for configuration to complete
Green, 3 flashes	Ready to operate in EPL mode
Green, constant	EPL mode
Red/Green (alternating, 200 ms)	Not participating in frame exchange, but observing EPL communications

### Drive Status LEDs

LED State—Left	Right	What it means
<b>Drive Enabled</b>		
Off	Green	Enabled
Yellow (flashes in Regen)	Green	Regeneration active
Yellow/Green (alternating)	Green	Autorun mode
<b>Drive Disabled</b>		
Off	Red	No faults, or Ethernet boot (8 sec)
Yellow	Off	Motor control boot (4 sec)
Yellow	Red	No bridge power
Yellow & 1 Green flash	Red	Bridge fault
Yellow & 2 Green flashes	Red	Feedback fault
Yellow & 3 Green flashes	Red	Thermal fault
Yellow & 4 Green flashes	Red	Other fault