

General Information

The "337" Series Flow Control Valves meter flow of air in one direction and allow free flow in the reverse direction.

The "337" Series valves are manufactured with a fine tapered needle providing precise flow control, even at low flow rates. The perimeter of the adjustment knob features numerical micrometer position markings providing a visual indication of the setting. Once the desired flow is selected, a set screw can be tightened to maintain the setting.

These valves are available with NPTF ports in 1/8", 1/4", 3/8", 1/2", and 3/4" sizes. This series is recommended for pneumatic service.

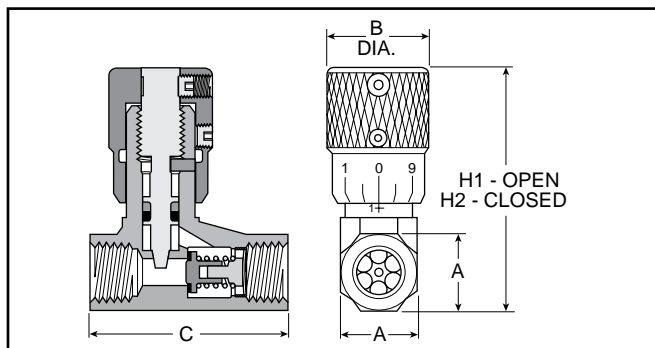

Valve Specifications

Maximum Operating Pressure 250 PSI
 Cracking pressure for return check poppet – 1 to 2 PSIG

Operating Temperature Standard: 0° to 180°F*
 Extended Temperature 0° to 300°F* (consult factory)

* Ambient temperatures below freezing require moisture-free air. Ambient temperatures below freezing and above 180° require lubricants especially selected for suitability at these temperatures. Pneumatic valves should be used with filtered and lubricated air.

Component Materials

- Body Material** Brass
- Needle** Stainless Steel
- Check Seal** Urethane
- Needle Seals** Buna N
 (Fluorocarbon optional – consult factory)
- Knob** Aluminum
- Spring** Stainless Steel
- Retainer** Zinc- Plated Steel
- Set Screw** Steel

Model Selection and Dimensions

Port Size	Model	Flow (SCFM†)		Dimensions					Service Kit
		Adj.	Free Flow	A	B	C	H1	H2	
1/8"	00337 1000	15	32	9/16"	0.75	1.47	2.03	1.81	00337 8000
1/4"	00337 1001	28	75	11/16"	0.75	1.47	2.28	2.03	00337 8001
3/8"	00337 1002	59	139	7/8"	0.88	2.31	2.84	2.53	00337 8002
1/2"	00337 1003	126	183	1-3/16"	1.06	3.25	3.62	3.22	00337 8003
3/4"	00337 1004	140	327	1-3/8"	1.06	3.25	3.72	3.31	00337 8004

† At 100 PSIG inlet pressure with full pressure drop.

Mounting Bracket Model Selection and Dimensions

Port Size	Mounting Bracket Model No.	Dimensions						
		A	B	C	D	E	F	G
1/8"	00337 8100	0.66	0.66	0.505	0.75	1.38	1.88	0.22
1/4"	00337 8101	0.75	0.89	0.505	0.75	1.50	2.00	0.22
3/8"	00337 8102	0.94	1.12	0.630	1.25	1.75	2.31	0.27
1/2"	00337 8103	1.25	1.62	0.755	1.75	2.06	2.62	0.27
3/4"	00337 8104	1.44	1.72	0.755	1.75	2.25	2.81	0.27

Mounting Bracket

