

# Series VH Hydraulic Cylinders

---

Series "VH" very heavy-duty hydraulic cylinders are premium quality cylinders—with operating capacities of 3,000 PSI. They fully meet NFPA standards. And to make sure every cylinder is premium-quality, Parker Hannifin subjects each and every one—not just batch samples—to tough inspection and performance tests.

## **OTHER SERIES "VH" FEATURES AND SPECIFICATIONS**

### **Ports**

Series "VH" ports are two sizes or larger than NFPA standards. Standard location is position 1 as shown in dimensional drawings. Where mountings do not interfere, ports may be located at positions 2, 3, or 4. Ports are not available at positions 2 or 4 on mounting style C, 2½" thru 5" bore cylinders. SAE straight thread O-ring ports will be supplied unless otherwise specified.

### **Cushions**

Cushions on Series "VH" cylinders are 3" long on all sizes except 3¼" and 4" bore sized equipped with 2" and 2½" diameter piston rods which are supplied with cushions 2⅓/₁₆" long at head end. Self-centering floating cushion sleeve at head end and cushion spear at cap is tapered for ⅔ its length to give maximum cushioning effect for ⅓ its length.

### **Thrust Key**

An extended retainer plate, to serve as a thrust key, can be supplied on mounting styles C and F. The thrust key would be the same as used on Parker Hannifin "2H" hydraulic cylinders.

### **Air Bleeds**

When specified, ⅛" NPTF bleed ports are available at either head or cap end. For design and location, ask for Drawing 81292.

### **Accessories**

Mounting accessories for Series "VH" are the same as used on Parker Hannifin Series 2H hydraulic cylinders. For dimensional data for rod clevis, knuckle, clevis bracket, mounting plate and pivot pin, see the Parker Series 2H section of this catalog.

\*See Section C for actual design factors.

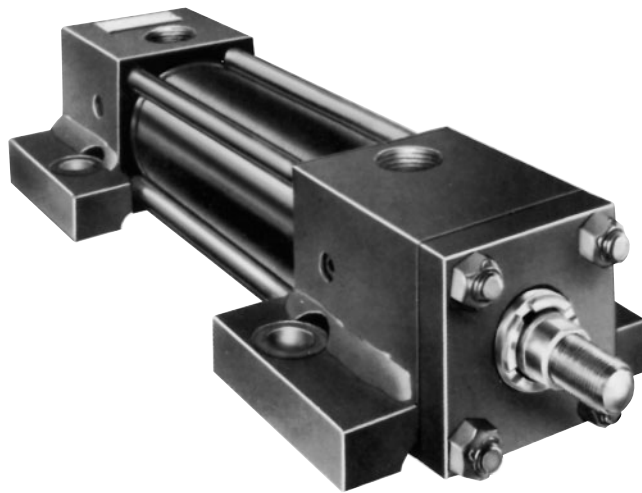

## **Extra-long Tapered Cushions Oversize Ports Meets N.F.P.A. Specifications**

Nominal Pressure - 3000 PSI  
Standard Bore Sizes - 2½" Through 8"  
Piston Rod Diameters - 1" Through 5½"  
Fifteen Standard Mounting Styles

---

**For additional information – call your local Parker Cylinder Distributor.**

# Parker Series VH Hydraulic Cylinders

## Mounting Styles Dimensions

### Basic Cylinder Style T (NFPA Style MX01)

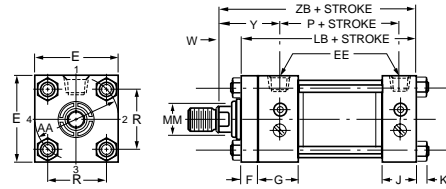

#### Rod end dimensions

BORE	ROD NO.	ROD DIA. MM	THREAD		ROD EXTENSIONS AND PILOT DIMENSIONS										BASIC ENVELOPE AND MOUNTING DIMENSIONS									
			CC	KK	A	<sup>+0.001</sup> B	C	D	LA	NA	V	W	Y	E	EE		F	G	J	K	ADD STROKE			
																NPTF	SAE					LB	P	ZB
2 1/2	1 (Std.)	1	7/8-14	3/4-16	1 1/8	1.499	1/2	7/8	1 7/8	15/16	1/4	3/4	4 1/8	3 1/2	1	16	5/8	3 3/4	3 1/2	7/16	9 3/8	3 1/2	10 9/16	
	2	1 3/4	1 1/2-12	1 1/4-12	2	2.374	3/4	1 1/2	3 1/4	1 1/16	1/2	1 1/4	4 5/8										11 1/16	
	3	1 3/8	1 1/4-12	1-14	1 5/8	1.999	5/8	1 1/8	2 5/8	1 5/16	3/8	1	4 3/8										10 13/16	
3 1/4	1 (Std.)	1 3/8	1 1/4-12	1-14	1 5/8	1.999	5/8	1 1/8	2 1/2	1 5/16	1/4	7/8	4 3/16	4 1/2	1 1/4	20	3/4	3 3/4	3 1/2	9/16	9 3/4	4 1/8	11 3/16	
	2	2	1 3/4-12	1 1/2-12	2 1/4	2.624	7/8	1 1/16	3 1/2	1 15/16	3/8	1 1/4	4 9/16										11 9/16	
	3	1 3/4	1 1/2-12	1 1/4-12	2	2.374	3/4	1 1/2	3 1/8	1 11/16	3/8	1 1/8	4 7/16										11 7/16	
4	1 (Std.)	1 3/4	1 1/2-12	1 1/4-12	2	2.374	3/4	1 1/2	3	1 11/16	1/4	1	4 7/16	5	1 1/4	20	7/8	3 3/4	3 1/2	9/16	10 1/8	4 3/8	11 11/16	
	2	2 1/2	2 1/4-12	1 7/8-12	3	3.124	1	2 1/16	4 3/8	2 3/8	3/8	1 3/8	4 13/16										12 1/16	
	3	2	1 3/4-12	1 1/2-12	2 1/4	2.624	7/8	1 1/16	3 3/8	1 15/16	1/4	1 1/8	4 9/16										11 13/16	
5	1 (Std.)	2	1 3/4-12	2 1/2-12	2 1/4	2.624	7/8	1 1/16	3 3/8	1 15/16	1/4	1 1/8	4 11/16	6 1/2	1 1/2	24	7/8	4	3 3/4	1 3/16	11 1/8	5 1/8	13 1/16	
	2	3 1/2	3 1/4-12	2 1/2-12	3 1/2	4.249	1	3	4 7/8	3 3/8	3/8	1 3/8	4 15/16										13 5/16	
	3	2 1/2	2 1/4-12	1 7/8-12	3	3.124	1	2 1/16	4 3/8	2 3/8	3/8	1 3/8	4 15/16										13 5/16	
	4	3	2 3/4-12	2 1/4-12	3 1/2	3.749	1	2 5/8	4 7/8	2 7/8	3/8	1 3/8	4 15/16										13 5/16	
6	1 (Std.)	2 1/2	2 1/4-12	1 7/8-12	3	3.124	1	2 1/16	4 1/4	2 3/8	1/4	1 1/4	4 7/8	7 1/2	2	32	1	4 1/4	4 1/4	7/8	12 3/8	6 1/8	14 1/2	
	2	4	3 3/4-12	3-12	4	4.749	1	3 3/8	5 1/4	3 7/8	1/4	1 1/4	4 7/8										14 1/2	
	3	3	2 3/4-12	2 1/4-12	3 1/2	3.749	1	2 5/8	4 3/4	2 7/8	1/4	1 1/4	4 7/8										14 1/2	
	4	3 1/2	3 1/4-12	2 1/2-12	3 1/2	4.249	1	3	4 3/4	3 3/8	1/4	1 1/4	4 7/8										14 1/2	
7	1 (Std.)	3	2 3/4-12	2 1/4-12	3 1/2	3.749	1	2 5/8	4 3/4	2 7/8	1/4	1 1/4	4 3/4										15	
	2	5	4 3/4-12	3 1/2-12	5	5.749	1	4 1/4	6 1/4	4 7/8	1/4	1 1/4	4 3/4										15	
	3	3 1/2	3 1/4-12	2 1/2-12	3 1/2	4.249	1	3	4 3/4	3 3/8	1/4	1 1/4	4 3/4	8 1/2	2	32	1	4 1/4	4 1/4	1 1/4	12 1/2	6 1/2	15	
	4	4	3 3/4-12	3-12	4	4.749	1	3 3/8	5 1/4	3 7/8	1/4	1 1/4	4 3/4										15	
	5	4 1/4	4 1/4-12	3 1/4-12	4 1/2	5.249	1	3 7/8	5 3/4	4 3/8	1/4	1 1/4	4 3/4										15	
8	1 (Std.)	3 1/2	3 1/4-12	2 1/2-12	3 1/2	4.249	1	3	4 3/4	3 3/8	1/4	1 1/4	4 3/4										16 1/4	
	2	5 1/2	5 1/4-12	4-12	5 1/2	6.249	1	4 5/8	6 3/4	5 3/8	1/4	1 1/4	4 3/4										16 1/4	
	3	4	3 3/4-12	3-12	4	4.749	1	3 3/8	5 1/4	3 7/8	1/4	1 1/4	4 3/4	9 1/2	2 1/2	32	1	4 1/2	4 1/2	1 1/2	13 1/2	7 1/2	16 1/4	
	4	4 1/2	4 1/4-12	3 1/4-12	4 1/2	5.249	1	3 7/8	5 3/4	4 3/8	1/4	1 1/4	4 3/4										16 1/4	
	5	5	4 3/4-12	3 1/2-12	5	5.749	1	4 1/4	6 1/4	4 7/8	1/4	1 1/4	4 3/4										16 1/4	

♦ SAE straight thread ports are standard and are indicated by port number. For dimensional information see Section C.

° NPTF ports are available at no extra charge.

#### PISTON ROD END THREADS

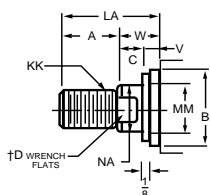

**PARKER THREAD  
STYLE 4  
(NFPA SM)**

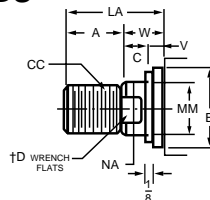

**PARKER THREAD  
STYLE 8  
(NFPA IM)**

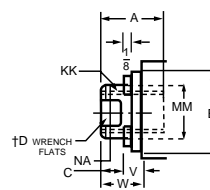

**PARKER THREAD  
STYLE 9  
(NFPA SF)**

Style 4 Rod Ends recommended for applications where workpiece is secured against rod shoulder. When workpiece is not shouldered, Style 4 Rod Ends are recommended through 2" rod diameter, Style 8 on larger diameters. If rod end is not specified, Style 4 will be furnished.

**NOTE:** Special piston rod end threads, two times length are available on 2 1/2" diameter piston rods and smaller. To order, specify thread Style 42 which has KK thread dia. or Style 82 which has CC thread dia. Other piston rod threads are available. To order, specify Style 3 and give desired dimensions for CC or KK, A and LA. For other specials, send dimensions or sketch.

† On 4 1/2" diameter rods and larger, 4 each .515 diameter spanner wrench holes will be provided.

#### Tie Rod Mounted Styles TB, TC, TD (NFPA Styles MX3, MX2, MX1)

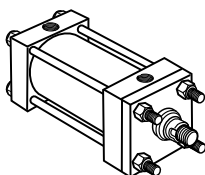

**Style TB  
(MX3)**

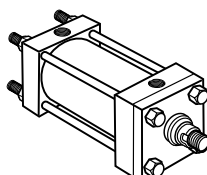

**Style TC  
(MX2)**

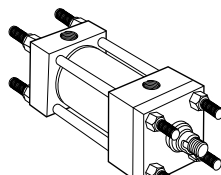

**Style TD  
(MX1)**

Style TB, Tie Rods Extended, is illustrated at right. Style TC, Cap Tie Rods Extended, and Style TD, Both Ends Tie Rods Extended, can be dimensioned from Style TB drawing.

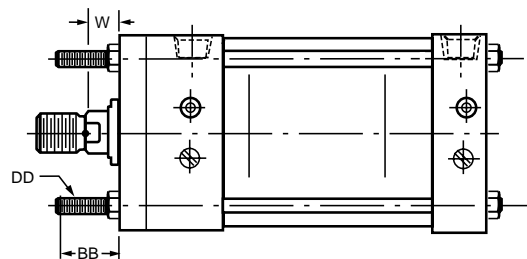

For Cylinder Division Plant Locations – See Page II.



# Mounting Styles Dimensions

# Parker Series VH Hydraulic Cylinders

## Flange Mountings

Style H, J, HB, JB

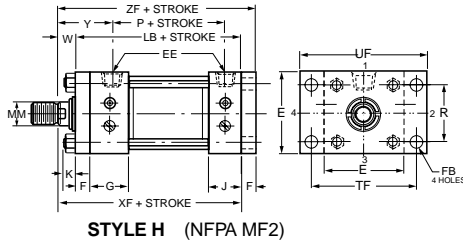

STYLE H (NFPA MF2)

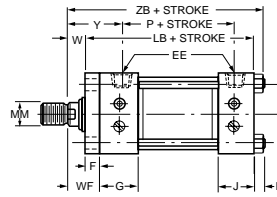

STYLE J (NFPA MF1)

## Style J

Bore Size	Maximum Pressure Rating, Push Application	
	Std. Rod	Code 2 Rod
2 1/2" thru 4"	2500	1500
5	2200	750
6	1800	750
7	1500	500
8	900	500

When pressure must exceed the maximum push or pull rating shown, specify Square Flange Mounting Styles HB or JB

## Side Mountings

Style C, CP, F, FP

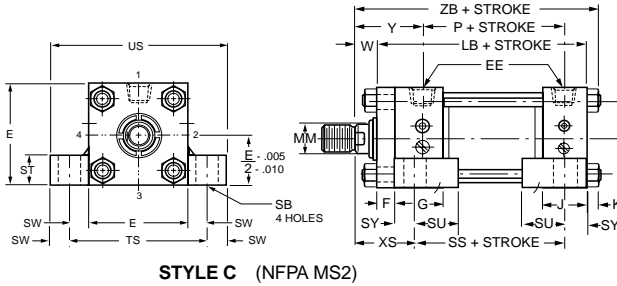

STYLE C (NFPA MS2)

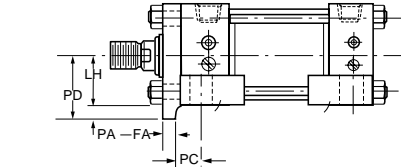

STYLE CP Side Lugs with Thrust Key Modification

## Pivot Mountings

Styles BB, DB, D, DD

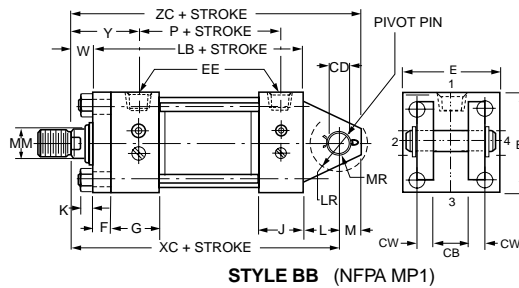

STYLE BB (NFPA MP1)

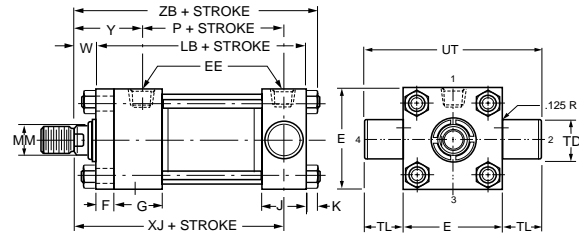

STYLE DB (NFPA MT2)

## Specific Dimensions for Series VH Mounting Styles (in inches)

BORE	ROD NO.	ROD DIA.	AA	BB	BD	CB	CD <sup>◆</sup>	CW	DD	FA <sup>◆◆</sup>	FB	L	LH <sup>◆◆</sup>	LR	M	MR	ND	NT	PA	PC	PD	PF	R	SB <sup>•</sup>	ST																							
2 1/2	1	1	3.6	1 13/16	1 1/2	1 1/4	.751	5/8	1/2-20	.562	9/16	1 1/4	1.744	15/16	3/4	15/16	9/16	5/8-11	5/16	2 3/4	2 1/16	3 1/16	2.55	13/16	1																							
	2	1 3/4															1 1/2	1 1/2								1 1/2	1 1/2	1 1/2	1 1/2	1 1/2	1 1/2	1 1/2	1 1/2	1 1/2	1 1/2	1 1/2	1 1/2	1 1/2	1 1/2	1 1/2	1 1/2	1 1/2	1 1/2	1 1/2	1 1/2			
	3	1 3/8															1 1/2	1 1/2								1 1/2	1 1/2	1 1/2	1 1/2	1 1/2	1 1/2	1 1/2	1 1/2	1 1/2	1 1/2	1 1/2	1 1/2	1 1/2	1 1/2	1 1/2	1 1/2	1 1/2	1 1/2	1 1/2	1 1/2	1 1/2	1 1/2	
3 1/4	1	1 3/8	4.6	2 5/16	2	1 1/2	1.001	3/4	5/8-18	.687	1 1/16	1 1/2	2.244	1 1/4	1	1 3/16	1 1/16	3/4-10	3/8	2 1/2	2 5/8	2 15/16	3.25	13/16	1																							
	2	2															1 1/2	1 1/2								1 1/2	1 1/2	1 1/2	1 1/2	1 1/2	1 1/2	1 1/2	1 1/2	1 1/2	1 1/2	1 1/2	1 1/2	1 1/2	1 1/2	1 1/2	1 1/2	1 1/2	1 1/2	1 1/2				
	3	1 3/4															1 1/2	1 1/2								1 1/2	1 1/2	1 1/2	1 1/2	1 1/2	1 1/2	1 1/2	1 1/2	1 1/2	1 1/2	1 1/2	1 1/2	1 1/2	1 1/2	1 1/2	1 1/2	1 1/2	1 1/2	1 1/2	1 1/2	1 1/2	1 1/2	
4	1	1 3/4	5.4	2 5/16	2	2	1.376	1	5/8-18	.812	1 1/16	2 1/8	2.494	1 3/4	1 3/8	1 5/8	1	1-8	7/16	2 11/16	2 15/16	2 15/16	3.82	1 1/16	1 1/4																							
	2	2 1/2															1 1/2	1 1/2								1 1/2	1 1/2	1 1/2	1 1/2	1 1/2	1 1/2	1 1/2	1 1/2	1 1/2	1 1/2	1 1/2	1 1/2	1 1/2	1 1/2	1 1/2	1 1/2	1 1/2	1 1/2	1 1/2				
	3	2															1 1/2	1 1/2								1 1/2	1 1/2	1 1/2	1 1/2	1 1/2	1 1/2	1 1/2	1 1/2	1 1/2	1 1/2	1 1/2	1 1/2	1 1/2	1 1/2	1 1/2	1 1/2	1 1/2	1 1/2	1 1/2	1 1/2	1 1/2	1 1/2	
5	1	2	7.0	3 3/16	2	2 1/2	1.751	1 1/4	7/8-14	.812	15/16	2 1/4	3.244	2 1/16	1 3/4	2 1/8	1 1/8	1-8	7/16	2 15/16	3 11/16	3 3/16	4.95	1 1/16	1 1/4																							
	2	3 1/2															1 1/8	1-8								1 1/8	1 1/8	1 1/8	1 1/8	1 1/8	1 1/8	1 1/8	1 1/8	1 1/8	1 1/8	1 1/8	1 1/8	1 1/8	1 1/8	1 1/8	1 1/8	1 1/8	1 1/8	1 1/8	1 1/8			
	3	2 1/2															1 1/8	1-8								1 1/8	1 1/8	1 1/8	1 1/8	1 1/8	1 1/8	1 1/8	1 1/8	1 1/8	1 1/8	1 1/8	1 1/8	1 1/8	1 1/8	1 1/8	1 1/8	1 1/8	1 1/8	1 1/8	1 1/8	1 1/8	1 1/8	1 1/8
	4	3															1 1/8	1-8								1 1/8	1 1/8	1 1/8	1 1/8	1 1/8	1 1/8	1 1/8	1 1/8	1 1/8	1 1/8	1 1/8	1 1/8	1 1/8	1 1/8	1 1/8	1 1/8	1 1/8	1 1/8	1 1/8	1 1/8	1 1/8	1 1/8	1 1/8
6	1	2 1/2	8.1	3 5/8	3	2 1/2	2.001	1 1/4	1-14	.937	1 1/16	2 1/2	3.744	2 5/16	2	2 3/8	1 1/4	1 1/4-7	1/2	3 3/16	4 1/4	3 5/16	5.73	1 5/16	1 1/2																							
	2	4															1 1/4	1 1/4-7								1 1/4	1 1/4	1 1/4	1 1/4	1 1/4	1 1/4	1 1/4	1 1/4	1 1/4	1 1/4	1 1/4	1 1/4	1 1/4	1 1/4	1 1/4	1 1/4	1 1/4	1 1/4	1 1/4	1 1/4			
	3	3															1 1/4	1 1/4-7								1 1/4	1 1/4	1 1/4	1 1/4	1 1/4	1 1/4	1 1/4	1 1/4	1 1/4	1 1/4	1 1/4	1 1/4	1 1/4	1 1/4	1 1/4	1 1/4	1 1/4	1 1/4	1 1/4	1 1/4	1 1/4	1 1/4	1 1/4
	4	3 1/2															1 1/4	1 1/4-7								1 1/4	1 1/4	1 1/4	1 1/4	1 1/4	1 1/4	1 1/4	1 1/4	1 1/4	1 1/4	1 1/4	1 1/4	1 1/4	1 1/4	1 1/4	1 1/4	1 1/4	1 1/4	1 1/4	1 1/4	1 1/4	1 1/4	1 1/4
7	1	3	9.3	4 1/8	3	3	2.501	1 1/2	1 1/8-12	.937	1 3/16	3	4.244	2 3/4	2 1/2	2 7/8	1 1/8	1 1/2-6	1/2	2 15/16	4 3/4	3 1/8	6.58	1 9/16	1 3/4																							
	2	5															1 1/8	1 1/2-6								1 1/8	1 1/8	1 1/8	1 1/8	1 1/8	1 1/8	1 1/8	1 1/8	1 1/8	1 1/8	1 1/8	1 1/8	1 1/8	1 1/8	1 1/8	1 1/8	1 1/8	1 1/8	1 1/8	1 1/8			
	3	3 1/2															1 1/8	1 1/2-6								1 1/8	1 1/8	1 1/8	1 1/8	1 1/8	1 1/8	1 1/8	1 1/8	1 1/8	1 1/8	1 1/8	1 1/8	1 1/8	1 1/8	1 1/8	1 1/8	1 1/8	1 1/8	1 1/8	1 1/8	1 1/8	1 1/8	1 1/8
	4	4															1 1/8	1 1/2-6								1 1/8	1 1/8	1 1/8	1 1/8	1 1/8	1 1/8	1 1/8	1 1/8	1 1/8	1 1/8	1 1/8	1 1/8	1 1/8	1 1/8	1 1/8	1 1/8	1 1/8	1 1/8	1 1/8	1 1/8	1 1/8	1 1/8	1 1/8
	5	4 1/2															1 1/8	1 1/2-6								1 1/8	1 1/8	1 1/8	1 1/8	1 1/8	1 1/8	1 1/8	1 1/8	1 1/8	1 1/8	1 1/8	1 1/8	1 1/8	1 1/8	1 1/8	1 1/8	1 1/8	1 1/8	1 1/8	1 1/8	1 1/8	1 1/8	1 1/8
8	1	3 1/2	10.6	4 1/2	3 1/2	3	3.001	1 1/2	1 1/4-12	.937	1 5/16	3 1/4	4.744	3 1/4	2 3/4	3 1/8	1 1/2	1 1/2-6	1/2	2 15/16	5 1/4	3 1/4	7.50	1 9/16	1 3/4																							
	2	5 1/2															1 1/2	1 1/2-6								1 1/2	1 1/2	1 1/2	1 1/2	1 1/2	1 1/2	1 1/2	1 1/2	1 1/2	1 1/2	1 1/2	1 1/2	1 1/2	1 1/2	1 1/2	1 1/2	1 1/2	1 1/2	1 1/2	1 1/2			
	3	4															1 1/2	1 1/2-6								1 1/2	1 1/2	1 1/2	1 1/2	1 1/2	1 1/2	1 1/2	1 1/2	1 1/2	1 1/2	1 1/2	1 1/2	1 1/2	1 1/2	1 1/2	1 1/2	1 1/2	1 1/2	1 1/2	1 1/2	1 1/2	1 1/2	1 1/2
	4	4 1/2															1 1/2	1 1/2-6								1 1/2	1 1/2	1 1/2	1 1/2	1 1/2	1 1/2	1 1/2	1 1/2	1 1/2	1 1/2	1 1/2	1 1/2	1 1/2	1 1/2	1 1/2	1 1/2	1 1/2	1 1/2	1 1/2	1 1/2	1 1/2	1 1/2	1 1/2
	5	5															1 1/2	1 1/2-6								1 1/2	1 1/2	1 1/2	1 1/2	1 1/2	1 1/2	1 1/2	1 1/2	1 1/2	1 1/2	1 1/2	1 1/2	1 1/2	1 1/2	1 1/2	1 1/2	1 1/2	1 1/2	1 1/2	1 1/2	1 1/2	1 1/2	1 1/2

◆ Dimension CD is pin diameter. • Upper surface spotfaced for socket head screws. ◆◆ Dimension to be specified by customer.

For additional information – call your local Parker Cylinder Distributor.

# Parker Series VH Hydraulic Cylinders

## Mounting Styles Dimensions

### Style H

Bore Size	Maximum Pressure Rating, Pull Application	
	Std. Rod	Code 2 Rod
2 1/2" thru 4"	3000	3000
5	2000	3000
6	2000	3000
7	1500	2000
8	1500	2000

For 7" & 8" bores, this style retainer configuration applies to all but J and JB mounts.

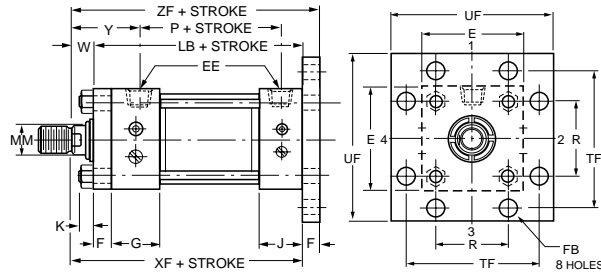
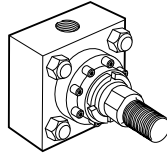

STYLE HB (NFPA MF6)

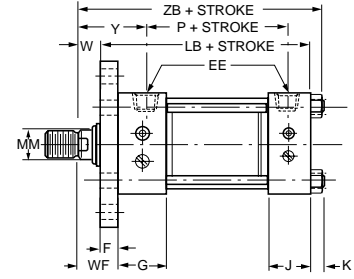

STYLE JB (NFPA MF5)

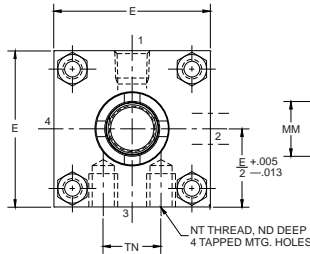

STYLE F (NFPA MS4)

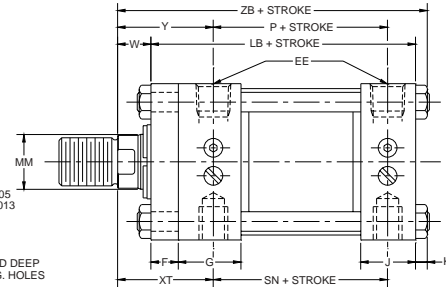

STYLE FP Side Tapped with Thrust Key Modification

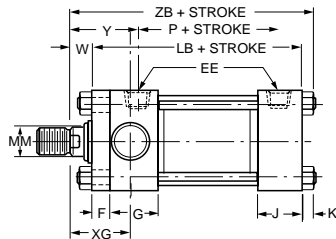

STYLE D (NFPA MT1)

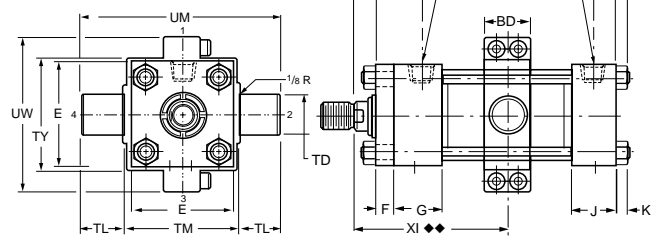

STYLE DD (NFPA MT4)

SU	SW	SY	+000 TD -001	TF	TL	TM	TN	TS	TY	UF	UM	UT	US	UW	XG	MIN. XI	DD MTG. MIN. STK.	XS	XT	add stroke						
																				SN	SS	XC	XF	XJ	ZC	ZF
1 9/16	1 1/16	2 11/16	1.375	4 5/8	1 3/8	4	1 5/16	4 7/8	3 3/4	5 3/8	6 3/4	6 1/4	6 1/4	4 5/8	4 1/4	5 15/16	1/8	4 1/16	4 3/8	3	3 3/8	11 3/8	10 1/8	7 3/8	12 1/8	10 3/4
1 9/16	1 1/16	2 7/16	1.750	5 7/8	1 3/4	5	1 1/2	5 7/8	4 3/4	7 1/8	8 1/2	8	7 1/4	5 13/16	4 3/8	6 1/16	3/8	4 1/16	4 1/2	3 1/2	4 1/8	12 1/2	10 5/8	8	13 1/8	11 3/8
2	7/8	2 5/8	1.750	6 3/8	1 3/4	5 1/2	2 1/16	6 3/4	5 1/4	7 7/8	9	8 1/2	8 1/2	6 3/8	4 5/8	6 11/16	1/8	4 1/2	4 3/4	3 3/4	4	13 1/4	11 1/8	8 1/2	14 5/8	12
2	7/8	2 7/8	1.750	8 3/16	1 3/4	7	2 15/16	8 1/4	6 3/4	9 3/4	10 1/2	10	10	7 3/4	5	7 1/16	0	4 7/8	5 1/8	4 1/4	4 1/2	14 1/2	12 1/4	9 5/8	16 1/4	13 3/8
2 1/2	1 1/8	3 1/8	2.000	9 7/16	2	8 1/2	3 5/16	9 3/4	7 3/4	11 1/4	12 1/2	11 1/2	12	10 3/4	5 3/8	8 1/16	1/4	5 3/8	5 1/2	5 1/8	5 1/8	16 1/8	13 5/8	10 3/8	18 1/8	14 5/8
2 7/8	1 3/8	2 7/8	2.500	10 5/8	2 1/2	9 3/4	3 3/4	11 1/4	8 3/4	12 5/8	14 3/4	13 1/2	14	11 1/2	5 1/8	8 1/16	1/8	5 1/8	5 1/16	5 7/8	5 3/4	16 3/4	13 3/4	10 7/8	19 1/4	14 3/4
2 7/8	1 3/8	2 7/8	3.000	11 13/16	3	11	4 1/4	12 1/4	9 3/4	14	17	15 1/2	15	13 3/8	5 1/4	8 3/16	1/8	5 1/8	5 1/16	6 5/8	6 3/4	18	14 3/4	11 3/4	20 3/4	15 3/4

For Cylinder Division Plant Locations – See Page II.



# DIMENSIONS

## DOUBLE ROD CYLINDERS

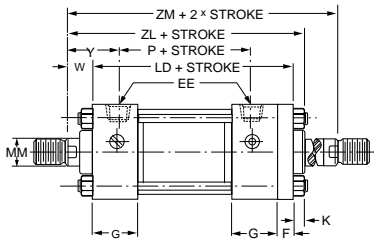

To obtain dimensioning information on a double rod cylinder, first select the desired mounting style and refer to the corresponding single rod cylinder model shown on the preceding pages. After you have determined all necessary dimensions from that drawing, turn back to this page and supplement those dimensions with additional ones from this drawing and the table at right. These added dimensions provide the additional information needed to completely dimension a double rod cylinder model.

On a double rod cylinder where the two rod ends will be different, be sure to state which rod end is to go at which end of the cylinder.

BORE SIZE	ROD NO.	ROD DIA.	ADD STROKE				ADD 2X STROKE			
			LD	ZL	SN <sub>K</sub>	SS <sub>K</sub>	ZM			
2 1/2	1	1	10 1/4	11 7/16	3	3 5/8	11 3/4			
	2	1 3/4		11 15/16			12 3/4			
	3	1 3/8		11 11/16			12 1/4			
3 1/4	1	1 3/8	10 3/4	12 3/16	3 1/2	4 3/8	12 1/2			
	2	2		12 9/16			13 1/4			
	3	1		12 7/16			13			
4	1	1 3/4	11 1/4	12 13/16	3 3/4	4 1/4	13 1/4			
	2	2 1/2		13 3/16			14			
	3	2		12 15/16			13 1/2			
5	1	2	12 1/4	14 3/16	4 1/4	4 3/4	14 1/2			
	2	3 1/2		14 7/16			15			
	3	2 1/2		14 7/16			15			
	4	3		14 7/16			15			
6	1	2 1/2	13 3/8	15 1/2	4 7/8	5 1/8	15 7/8			
	2	4		13 1/2			15 3/4	5 3/8	5 3/4	16
	3	3								
	4	3 1/2								
7	1	3	14 1/2	16 13/16	6 1/8	6 3/4	17			
	2	5								
	3	3 1/2								
	4	4								
	5	4 1/2								
8	1	3 1/2	14 1/2	16 13/16	6 1/8	6 3/4	17			
	2	5 1/2								
	3	4								
	4	4 1/2								
	5	5								
REPLACES			LB	ZB	SN	SS	—			
ON SINGLE ROD MOUNTING STYLE . . . . .			ALL MTG. STYLES		F	C	ALL MTG.			

### HOW TO ORDER SERIES VH CYLINDERS

Note: Parker Series VH Cylinders can be completely & accurately described by a model number consisting of coded symbols. To develop a model number select only those symbols that represent the cylinder required and place them in the sequence shown in the chart below.

SERIES VH MODEL NUMBERS—HOW TO DEVELOP THEM—HOW TO DECODE THEM.																	
E	BORE SIZE	CUSHION HEAD END	DOUBLE ROD	MOUNTING STYLE	MOUNTING MOD.	COMBINATION MOUNTING STYLE	SERIES	PISTON	PORTS	COMMON MODIFICATION	SPECIAL MODIFICATIONS	PISTON ROD NO.	ROD END THREAD STYLE NO.	ALTERNATE STANDARD ROD END THD. LENGTH	THREAD TYPE	CUSHION CAP END	STROKE
X	6	C	K	C	P	TB	VH		T	V	S	1	4	2	A	C	X50
A	Specify 2 1/2" thru 8"	Specify only if Cushion Head End is required	Use only if Double Rod Cyl. is required	Specify mounting style T, TB, TC, TD, F, H, J, BB, C, D, DB, DD, HB, JB.	Specify P-for Thrust Key Mtg. M-for Manifold Ports	Specify any practical mtg. style available	Specify Series VH	For ring type piston no letter req'd. Use K for Hi-load Piston	Specify Port Type req'd. U=NPTF T=S.A.E. P=S.A.E. Flange Ports R=BSP B=BSPT G=Metric Y=metric ISO 6149	If required specify V=Viton Seals F=Nut Retained Piston X=E.P.R. Seals W=Water Service J=High Water Content Fluid See Section C	Specify only if special modifications are required. Do not use symbol "S" for rod end modifications.	Specify rod code no. See chart in Section C for min. Piston rod diameter	Specify Style 4 Small Male Style 8 Intermediate Male Style 9 Short Female Style 3 Special. Specify KK, A, LA or W dim. req'd	Specify only if 2 times Standard Catalog "A" dim. is required	Specify A=UNF W=BSF M=Metric	Specify only if Cushion Cap End is required	Specify in inches. Show symbol "X" just ahead of stk. length.

**Class 1 SEALS**  
Class 1 seals are the seals provided as standard in a cylinder assembly unless otherwise specified. For further information on fluid compatibility on operating limitations of all compounds, see Section C.  
For the VH series cylinders the following make-up Class 1 Seals:

- Primary Piston Rod Seal—Enhanced Polyurethane
- Piston Rod Wiper—Nitrile
- Piston Seals—Cast Iron Rings
  - Option—Nitrile lipseals with polymyte back-up washers
  - Option—Hi-Load, Filled P.T.F.E. seals with a nitrite expander
- O-rings—Nitrile (nitrile back-up washer when used)

For additional information – call your local Parker Cylinder Distributor.