

**07F Filters – Standard**

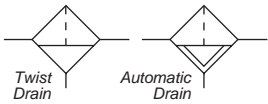

**Features**

- Excellent water removal efficiency.
- Unique deflector plate and shroud creates a swirling of the air stream ensuring maximum water and dirt separation.
- Large filter element surface guarantees low pressure drop and increased element life.
- Optional automatic float drain available.
- Shown with recommended metal bowl guard.
- High Flow: 1/2" – 130 SCFM<sup>§</sup>  
 3/4" – 145 SCFM<sup>§</sup>

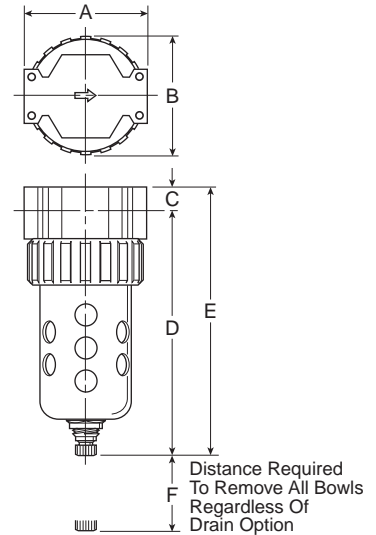

Distance Required To Remove All Bowls Regardless Of Drain Option

Port Size	NPT	
	Twist Drain	Automatic Float Drain
Poly Bowl <sup>†</sup> / Metal Guard		
1/2"	<b>07F32A*</b>	<b>07F36A*</b>
3/4"	<b>07F42A*</b>	<b>07F46A*</b>
Metal Bowl / Sight Gauge		
1/2"	<b>07F34A*</b>	<b>07F38A*</b>
3/4"	<b>07F44A*</b>	<b>07F48A*</b>

07F Filter Dimensions		
<b>A</b> 3.24 (82)	<b>B</b> 3.25 (83)	<b>C</b> .70 (18)
<b>D</b> 6.97 (177)	<b>D<sup>†</sup></b> 7.00 (178)	<b>E</b> 7.67 (195)
<b>E<sup>†</sup></b> 7.70 (196)	<b>F</b> 2.75 (70)	

Inches (mm)

<sup>†</sup> With Automatic Float Drain

Standard part numbers shown bold.

For other models refer to ordering information below.

<sup>‡</sup> For polycarbonate bowl see Caution on page C2.

<sup>§</sup> SCFM = Standard cubic feet per minute at 90 psig inlet and 5 psig pressure drop.

**Ordering Information**

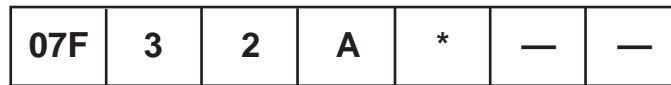

<b>Port Size</b> 3 1/2 Inch 4 3/4 Inch	<table border="1"> <thead> <tr> <th colspan="2">Bowl Options</th> </tr> </thead> <tbody> <tr> <td><u>Polycarbonate Bowl</u></td> <td><u>Metal Bowl</u></td> </tr> <tr> <td>2 Metal Bowl Guard / Twist Drain</td> <td>3 Twist Drain</td> </tr> <tr> <td>6 Metal Bowl Guard / Auto Float Drain</td> <td>4 Sight Gauge / Twist Drain</td> </tr> <tr> <td></td> <td>7 Auto Float Drain</td> </tr> <tr> <td></td> <td>8 Sight Gauge / Auto Float Drain</td> </tr> </tbody> </table>	Bowl Options		<u>Polycarbonate Bowl</u>	<u>Metal Bowl</u>	2 Metal Bowl Guard / Twist Drain	3 Twist Drain	6 Metal Bowl Guard / Auto Float Drain	4 Sight Gauge / Twist Drain		7 Auto Float Drain		8 Sight Gauge / Auto Float Drain	<table border="1"> <thead> <tr> <th>Elements</th> </tr> </thead> <tbody> <tr> <td>A 40 Micron</td> </tr> <tr> <td>B 5 Micron</td> </tr> </tbody> </table>	Elements	A 40 Micron	B 5 Micron	<table border="1"> <thead> <tr> <th>Engineering Level</th> </tr> </thead> <tbody> <tr> <td>* Will be Entered at Factory</td> </tr> </tbody> </table>	Engineering Level	* Will be Entered at Factory	<table border="1"> <thead> <tr> <th>Options</th> </tr> </thead> <tbody> <tr> <td>Blank None</td> </tr> </tbody> </table>	Options	Blank None	<table border="1"> <thead> <tr> <th>Port Type</th> </tr> </thead> <tbody> <tr> <td>Blank NPT</td> </tr> <tr> <td>1* BSPP</td> </tr> </tbody> </table> <p>* 1/2 inch meets ISO 1179-1 Standard.</p>	Port Type	Blank NPT	1* BSPP
Bowl Options																											
<u>Polycarbonate Bowl</u>	<u>Metal Bowl</u>																										
2 Metal Bowl Guard / Twist Drain	3 Twist Drain																										
6 Metal Bowl Guard / Auto Float Drain	4 Sight Gauge / Twist Drain																										
	7 Auto Float Drain																										
	8 Sight Gauge / Auto Float Drain																										
Elements																											
A 40 Micron																											
B 5 Micron																											
Engineering Level																											
* Will be Entered at Factory																											
Options																											
Blank None																											
Port Type																											
Blank NPT																											
1* BSPP																											

**BOLD ITEMS ARE MOST POPULAR.**

Technical Information

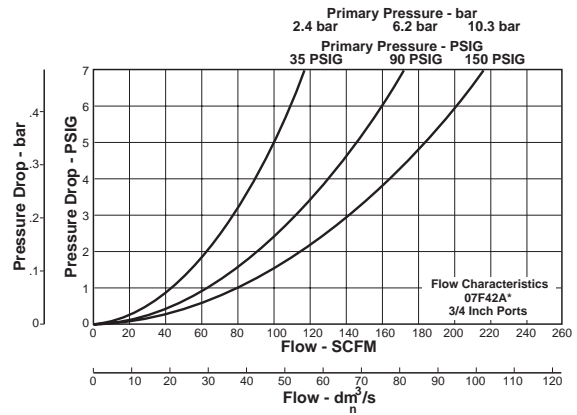
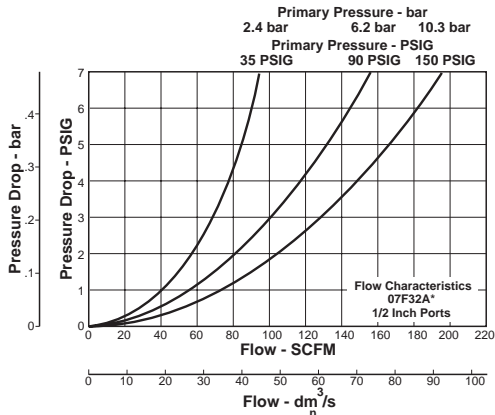

07F Filter Kits & Accessories

- Bowl Guard Kit ..... PS805P
  - Bowl Kits –
    - Poly Bowl –
      - Automatic Float Drain ..... PS822P
      - Twist Drain ..... PS832P
    - Metal Bowl –
      - Automatic Float Drain ..... PS826P
      - Twist Drain ..... PS834P
      - Sight Gauge / Automatic Drain ..... PS823P
      - Sight Gauge / Twist Drain ..... PS835P
  - DPI Replacement Kit ..... PS781P
  - Drain Kits –
    - Automatic Float Drain ..... PS506P
    - Semi-Auto Drain ..... PS511P
    - Twist Drain ..... PS512P
    - Push ‘N’ Drain ..... PS513P
  - Filter Element Kits –
    - 40 Micron ..... PS801P
    - 5 Micron ..... PS802P
    - Adsorber ..... PS831P
  - Mounting Bracket Kit ..... PS843P
  - Sight Gauge Kit ..... PS914P
- Specifications**
- Bowl Capacity ..... 7.2 Ounces
  - Sump Capacity ..... 2.8 Ounces
  - Port Threads ..... 1/2, 3/4 Inch

Pressure & Temperature Ratings –

- Without Differential Pressure Indicator:
  - Polycarbonate Bowl – 0 to 150 psig (0 to 10.3 bar)  
32°F to 125°F (0°C to 52°C)
  - Metal Bowl – 0 to 250 psig (0 to 17.2 bar)  
32°F to 175°F (0°C to 80°C)
- With Differential Pressure Indicator:
  - 0 to 150 psig (0 to 10.3 bar)  
32°F to 125°F (0°C to 52°C)
  - Automatic Float Drain – 15 to 250 psig (1.0 to 17.2 bar)

Weight ..... 2.2 lb. (1.0 kg)

Materials of Construction

- Body ..... Zinc
- Bowls ..... Transparent Polycarbonate  
Metal (Zinc) With or Without Sight Gauge
- Bowl Guards ..... Steel
- Collar ..... Plastic or Metal
- Deflector, Shroud & Baffle ..... Plastic
- Drains –
  - Twist Drain – Body & Nut ..... Plastic
  - Push ‘N’ Drain –
    - Body ..... Nitrile
    - Stem ..... Brass
  - Automatic Float Drain –
    - Housing, Float ..... Plastic
    - Seals ..... Nitrile
    - Springs, Push Rod ..... Stainless Steel
- Filter Elements –
  - 40 Micron (Standard) ..... Plastic
  - 5 Micron (Optional) ..... Plastic
  - Adsorber (Optional) ..... Activated Charcoal
- Seals ..... Nitrile
- Sight Gauge ..... Polyamide

C
Product Selection
Filters
Coalescers
Regulators
Filter / Regulators
Lubricators
Compos
Accessories