

06L Mist Lubricators – Compact

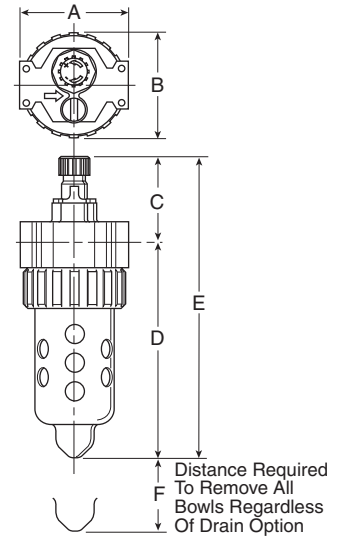

Features

- Proportional oil delivery over a wide range of air flows.
- Precision needle valve assures repeatable oil delivery and provides simple adjustment of delivery rate.
- Bowl can be filled while air line is under pressure.
- Transparent sight dome for 360° visibility.
- High Flow: 1/4" – 40 SCFM[§]
 3/8" – 60 SCFM[§]
 1/2" – 90 SCFM[§]



Distance Required To Remove All Bowls Regardless Of Drain Option

Port Size	NPT	
	Twist Drain	No Drain
Poly Bowl † / Metal Guard		
1/4"	—	06L12B*
3/8"	—	06L22B*
1/2"	—	06L32B*
Metal Bowl / Sight Gauge		
1/4"	06L14B*	—
3/8"	06L24B*	—
1/2"	06L34B*	—

06L Lubricator Dimensions		
A 2.81 (71)	B 2.74 (70)	C 2.24 (57)
D 5.58 (142)	D† 5.69 (145)	E 7.82 (199)
E† 7.93 (201)	F 2.25 (57)	

Inches (mm)
 †With Twist Drain.

Standard part numbers shown bold. For other models refer to ordering information below.

† For polycarbonate bowl and sight dome, see Caution on page C2.

§ SCFM = Standard cubic feet per minute at 90 psig inlet and 5 psig pressure drop.

Ordering Information

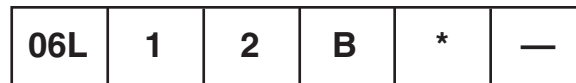

Port Size	Bowl Options		Options	Engineering Level	Port Type
1 1/4 Inch	Polycarbonate Bowl		B With Fill Plug	* Will be Entered at Factory	Blank NPT
2 3/8 Inch	2 Metal Bowl Guard / No Drain	4 Sight Gauge / Twist Drain	C With Fill Plug/Nylon Sight Dome		1* BSPP
3 1/2 Inch	6 Metal Bowl Guard / Pressure Fill	8 Sight Gauge / Pressure Fill	F With Body Pressure Fill		* 1/4 & 3/8 inch meet ISO 1179-1 Standard.
	K Metal Bowl Guard / Auto Fill Device	M Sight Gauge / Auto Fill Device	G With Body Pressure Fill / Nylon Sight Dome		
	N Metal Bowl Guard / Twist Drain				

BOLD ITEMS ARE MOST POPULAR.



Technical Information

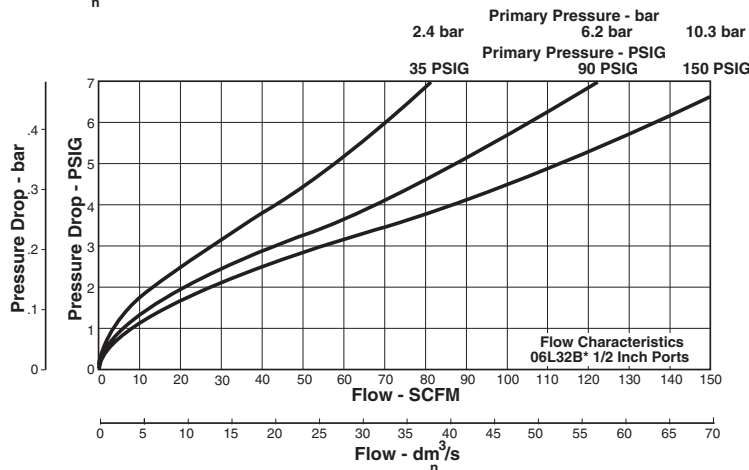
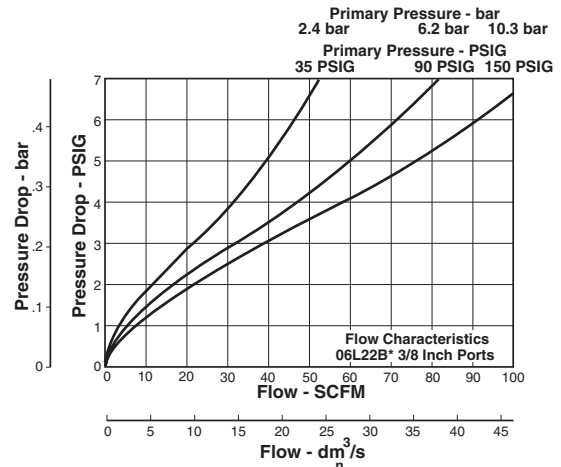
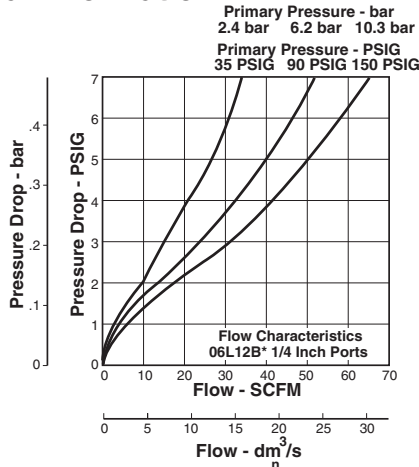

06L Mist Lubricator Kits & Accessories

Adjustment Knob	P04121
Bowl Guard Kit	PS705P
Bowl Kits –	
Poly Bowl – No Drain	PS746P
Twist Drain	PS717P
Pressure Fill	PS719P
Remote Fill	PS728P
Metal Bowl – Sight Gauge / Twist Drain	PS729P
Sight Gauge / Pressure Fill	PS720P
Drain Kit – Twist Drain	PS512P
Fill Cap Kit	PS741P
Lubricator Service Kit	PS718P
Mounting Bracket Kit	PS743P
Oil – 1 Gal.	F442002
12 Quart Case	F442003
4 Gallon Case	F442005
Pressure Fill Adapter Kit	PS716P
Pressure Fill Button	P11912
Remote Auto-Fill Device	PS505CP
Sight Dome / Fill Cap Kit	PS738P
Sight Dome Kit	PS740P
Nylon Sight Dome Kit	PS740N

Specifications

Bowl Capacity 2.9 Ounces
Minimum Flow for Lubrication5 SCFM At 100 psig
Port Threads 1/4, 3/8, 1/2 Inch
Pressure & Temperature Rating –
 Polycarbonate Bowl – 0 to 150 psig (0 to 10.3 bar)
 32°F to 125°F (0°C to 52°C)
 Metal Bowl – 0 to 250 psig (0 to 17.2 bar)
 32°F to 175°F (0°C to 80°C)
Suggested Lubricant F442 Oil
 Petroleum based oil of 100 to 200 SSU viscosity at 100°F (38°C)
 and an aniline point greater than 200°F (93°C)
 (DO NOT USE OILS WITH ADDITIVES, COMPOUNDED OILS
 CONTAINING SOLVENTS, GRAPHITE, DETERGENTS, OR
 SYNTHETIC OILS.)

Weight 1.2 lb. (0.5 kg)

Materials of Construction

Body Zinc
Bowls – Transparent Polycarbonate
 Metal (With Sight Gauge) Zinc
Bowl Guard Steel
Collar Plastic
Drain – Twist – Body & Nut Plastic
Injector Meter Block & Base Assembly Plastic
Seals Nitrile
Sight Dome Polycarbonate
Sight Gauge Polyamide (Nylon)

C
Product Selector
Filters
Coalescers
Regulators
Filter / Regulators
Lubricators
Combos
Accessories

