

04L Mist Lubricators – Miniature

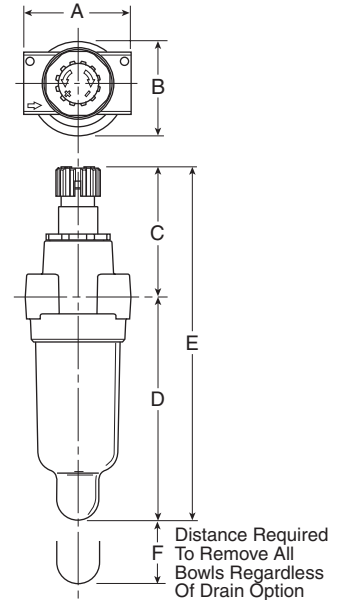

Features

- Proportional oil delivery over a wide range of air flows.
- Precision needle valve assures repeatable oil delivery and provides simple adjustment of delivery rate.
- Ideal for low and high flow applications with changing air flow.
- Transparent sight dome for 360° visibility.
- High Flow: 1/8" – 20 SCFM[§]
 1/4" – 20 SCFM[§]



Distance Required To Remove All Bowls Regardless Of Drain Option

Port Size	NPT	
	Twist Drain	No Drain
Poly Bowl †		
1/8"	—	04L00G*
1/4"	—	04L10G*
Metal Bowl without Sight Gauge		
1/8"	04L03G*	—
1/4"	04L13G*	—

04L Lubricator Dimensions		
A	B	C
1.73 (44)	1.56 (40)	2.16 (55)
D	D†	E
3.64 (92)	3.78 (96)	5.80 (147)
E†	F	
5.94 (151)	1.60 (41)	

Standard part numbers shown bold. For other models refer to ordering information below.

† For polycarbonate bowl and sight dome, see Caution on page C2.
 § SCFM = Standard cubic feet per minute at 90 psig inlet and 5 psig pressure drop.

Inches (mm)
 † With Twist Drain.

Ordering Information

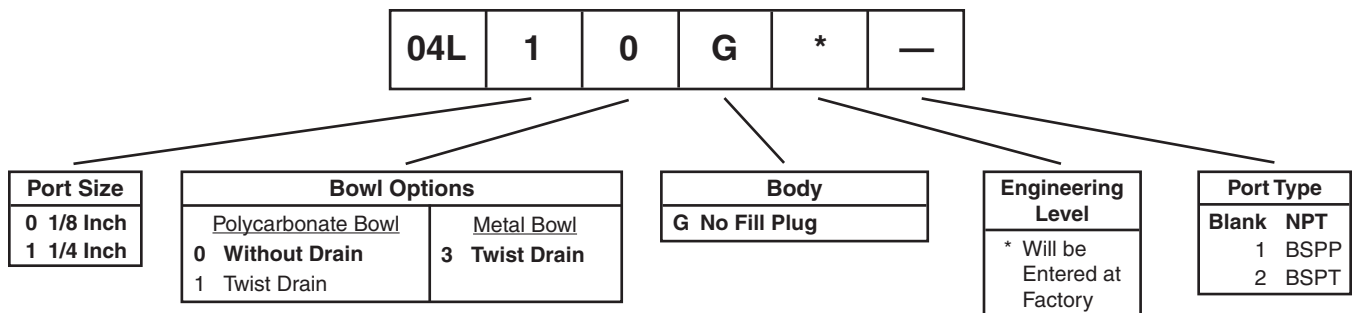

BOLD ITEMS ARE MOST POPULAR.



Technical Information

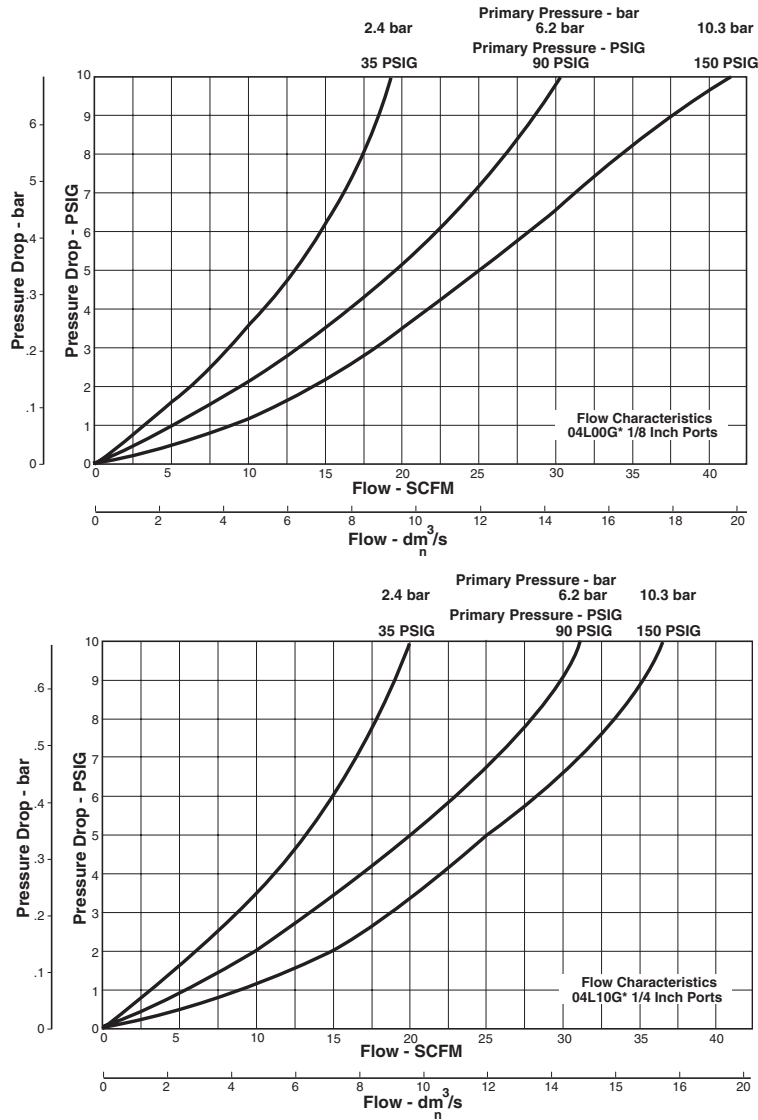

04L Mist Lubricator Kits & Accessories

Bowl Kits –

- Poly Bowl – No DrainPS421P
- Twist DrainPS420P
- Metal Bowl – Twist Drain (No Sight Gauge).....PS447BP

Mounting Bracket Kit PS419

- Oil – 1 Gal.**.....F442002
- 12 Quart Case.....F442003
- 4 Gallon CaseF442005

Specifications

- Bowl Capacity** 1 Ounce
- Minimum Flow for Lubrication** 0.5 SCFM at 100 psig
- Port Threads** 1/8, 1/4 Inch
- Pressure & Temperature Ratings –**
 - Polycarbonate Bowl – 0 to 150 psig (0 to 10.3 bar)
 32°F to 125°F (0°C to 52°C)
 - Metal Bowl – 0 to 250 psig (0 to 17.2 bar)
 32°F to 175°F (0°C to 80°C)

Suggested Lubricant –F442 Oil
 Petroleum based oil of 100 to 200 SSU viscosity at 100°F (38°C) and an aniline point greater than 200°F (93°C).
 (DO NOT USE OILS WITH ADDITIVES, COMPOUNDED OILS CONTAINING SOLVENTS, GRAPHITE, DETERGENTS, OR SYNTHETIC OILS.)
Weight0.4 lb. (0.18 kg)

Materials of Construction

- Body** Zinc
- Bowls –** Transparent Polycarbonate
 Metal (Without Sight Gauge)..... Zinc
- Drains –** Twist – Body & NutPlastic
- Seals**Nitrile
- Sight Dome** Polycarbonate

C	Product Selection
Filters	Coalescers
Regulators	Filter / Regulators
Lubricators	Combos
Accessories	

