

CS 1000 Series Contamination Sensor

CS 1000 with Block Kit
and display



CS 1000 without display

CS 1000 with display

Description

The CS 1000 Contamination Sensor is the latest HYDAC development for continuous measurement of solid contamination of fluids.

Using the latest technology and materials, the CS 1000 is a reliable measuring instrument that is permanently mounted on your mobile or industrial equipment.

The attractive cost-to-performance ratio makes it especially interesting for OEM applications. Online, real-time condition monitoring allows you to have total predictive maintenance.

Applications

Monitoring system on vehicles such as

- Construction equipment
- Agricultural machinery
- Mobile and stationary mining equipment

Industrial hydraulic systems

- Integration into power unit monitoring systems
- Hydraulic test stands

Combination with filter unit

CS 1000 Block KIT

The Contamination Sensor Block KIT (CS 1000 Block KIT) combines two condition monitoring products, the CS 1000 series (Contamination Sensor) and the AS 1000 series (Aqua Sensor) into one plug and play unit. It serves as an on-line measurement of both solid contamination and water in hydraulic and lube systems.

Note: Flow control is necessary when utilizing the CS 1000 sensor. Flow must be maintained through the sensor module to ensure accurate readings. Utilization of the CS Block Kit is required to maintain Sensor flow rate range as described in the Technical Details (at the right).

Features

- Versions with or without display
- Display with pivot-function
- Display with 6-digit ISO Code (optional)
- Measurement of solid particle contamination in hydraulic and lubricating fluids
- Compact and rugged design
- Type of protection IP67
- Max. pressure 4350 psi
- Max. viscosity 4635 SUS (1000 cSt)
- Voltage supply 9 - 36VDC
- Data output 4 - 20mA or 0 - 10 VDC

Technical Details

Self-diagnosis	Continuously with error indication via status LED
Measuring range	Display up to class ISO 7/6/5 to 28/27/26 Calibration within the range ISO 13/11/10 to 23/21/18
Contamination code	ISO 4406 : 1999 SAE AS 4059 (D)
Operation pressure	4350 psi max
Connectors	
Inlet	Thread G 1/4, ISO 228
Outlet	Thread G 1/4, ISO 228
Sensor flow rate	1 - 10 oz/m
Permissible viscosity range	15 - 4635 SUS (1 - 1000 cSt)
Fluid temperature range	32° to 185°F (0° to 85°C)
Power supply voltage	9 - 36 VDC, residual ripple < 10%
Power consumption	3 Watt maximum
Electrical specification	
4 to 20 mA output:	Max. 330 Ω
0 to 10 V output:	Min. 820 Ω Max. current 1.5 A
Electrical outputs	
Analog Interfaces	4 to 20 mA (max 330 Ω) 0 to 10 VDC (min 820 Ω)
Limit Switching Output	Passive, n-switching power MOSFET, max current 1.5A
RS485	2 conductor cable
Operating temperature range	-22° to 176°F (-30° to 80°C)
Relative Humidity	max. 95%, non-condensing
Seal Material	
Hydraulic/Mineral Oil	Fluoro-elastomer (FPM)
Phosphate Ester	Ethylene Propylene (EPDM)
Electrical safety class	III (low voltage protection)
IP class	IP67
Weight	2.9 lbs. (1.3 kg)

We do not guarantee the accuracy or completeness of this information. The information is based on average working condition. For exceptional operating conditions please contact our technical department. All details are subject to technical changes.

Model Code

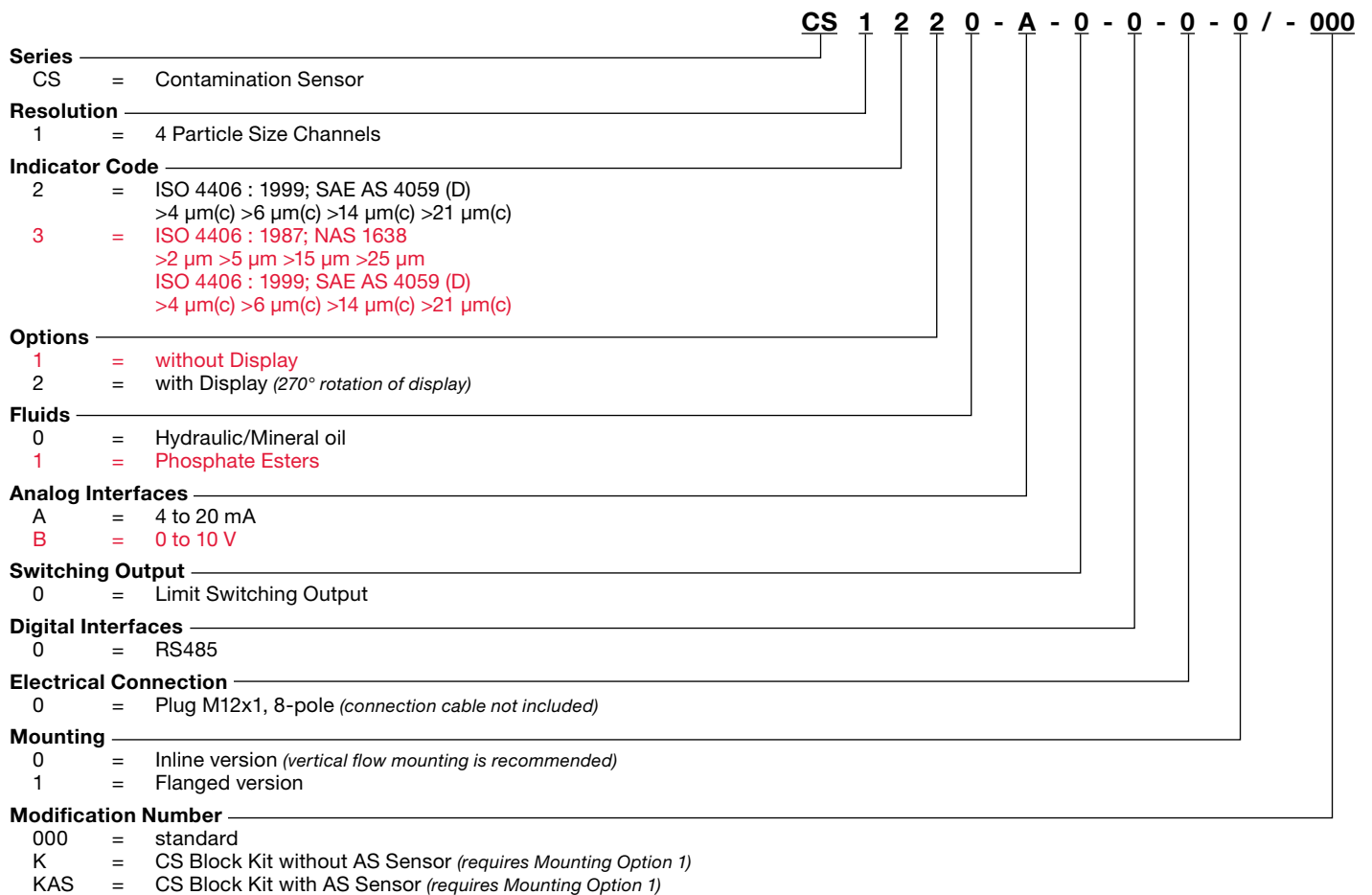

Scope Of Delivery

- Contamination sensor
- Operation and Instruction manual
- Calibration Certificate

Accessories

- Connection cable 6 ft. with M12x1 connector, screened 8-pole: Part Number 03281220
- Connection cable 16 ft. with M12x1 connector, screened 8-pole: Part Number 03281239
- Connection cable 9 ft. with M12x1 connector, 8-pole: Part Number 02091414
- CSI-D-5 Contamination Sensor Interface: Part Number 03249563

Model Codes Containing RED are non-standard items – Minimum quantities and longer lead times may apply - Contact HYDAC for information and availability

CS 1000 Block Kit

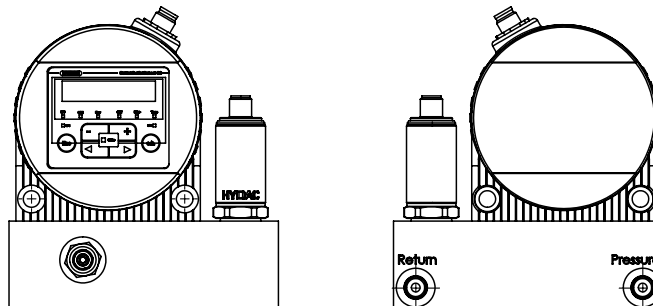

Quick Order Guide

Model Code	Part Number	Description
CS1220-A-0-0-0-0 /-000	03236362	4-20mA display model
CS1210-A-0-0-0-0 /-000	03240458	4-20mA non-display model
Connection Cable	03281220	6 foot
CS1220-A-0-0-0-1 / K	02087348	4-20mA display model and CS Block Kit without AS Sensor
CS1220-A-0-0-0-1 / KAS	02086855	4-20mA display model and CS Block Kit with AS Sensor

HYDAC Contamination Monitors

Dimensions CS 1000 with Block Kit

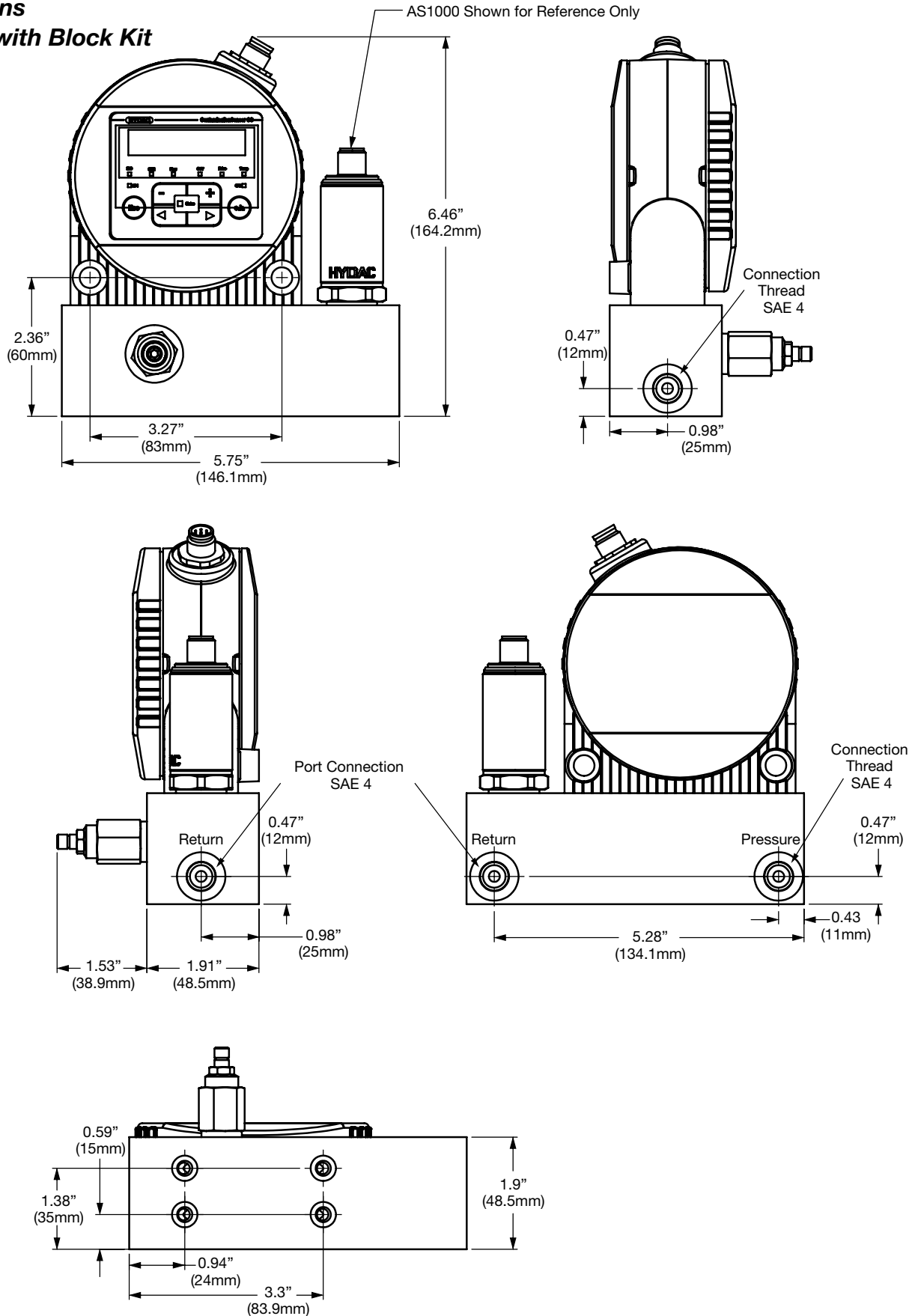

Dimensions are for general information only. All critical dimensions should be verified by requesting a certified print.

Hydraulic Connections Inline Version

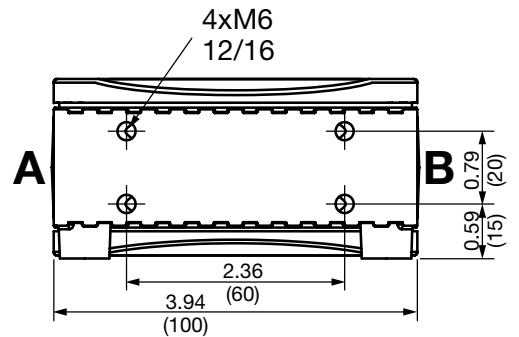
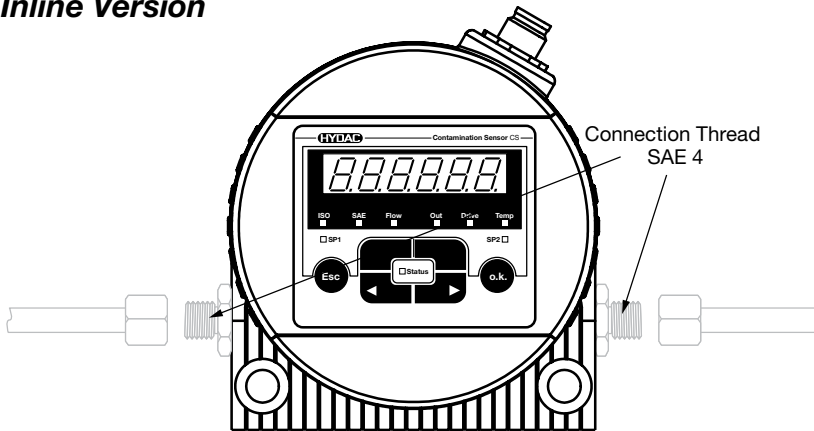

Flanged Version

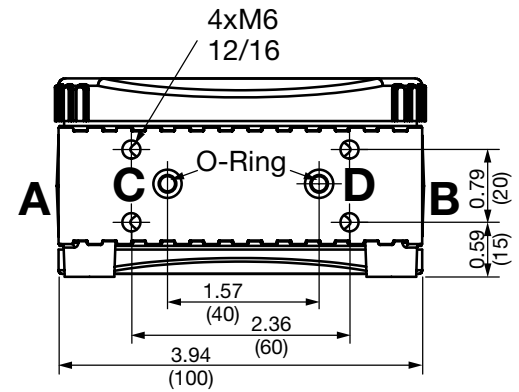
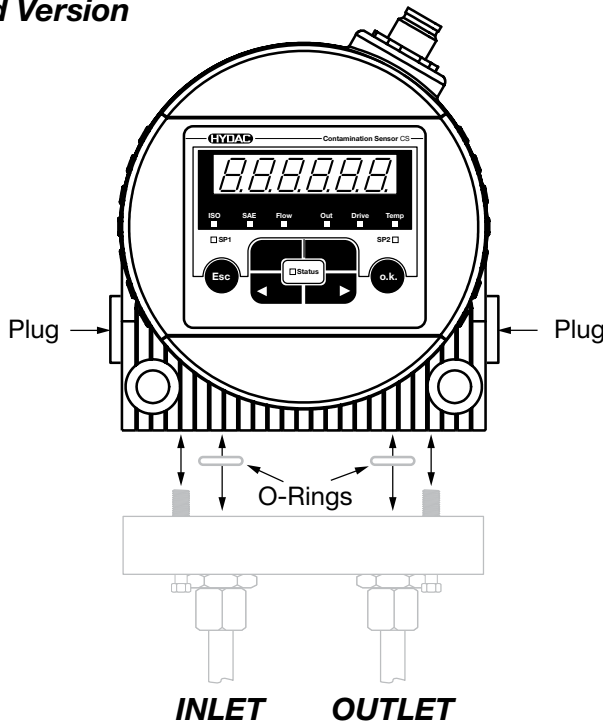

Pressure - Viscosity Range

