

Chelsea® 352 Series

One Speed Forward and Reverse
Mechanical P.T.O.



Overview:

The Chelsea 352 Series P.T.O. is another example of why Chelsea P.T.O. technology is the best in the business. This economical workhorse features cast iron housing and heavy duty tapered bearing on the output shaft, giving it a high torque rating and long service life. Chelsea was the first to provide you with an Air shifted forward and reverse speed P.T.O. The flexible Air shift design allows you to mount the air shift cylinder in the best position for maximum clearance. Torque rating up to 140 Lbs. ft. makes this one versatile P.T.O. Take advantage of over 65 years of Chelsea P.T.O. technology to increase performance and lower costs.

- Oil Field
- Logging



Product Features and Benefits:

Contact Information:

Parker Hannifin Corporation
Chelsea Products Division
8225 Hacks Cross Road
Olive Branch, MS 38654 USA

Phone: 1-888-PH4-TRUK
(1-888-744-8785)

Fax: 1-662-895-1069
chelseacustserv@parker.com

www.parker.com/chelsea

- Offers faster speeds than the 340 Series
- Same input gears as the 442 Series
- Designed with tapered roller bearings for maximum durability
- 6-Bolt Mounting Pad
- Two Year Warranty
- Shift options include wire, lever and air



ENGINEERING YOUR SUCCESS.

Model Number Designation

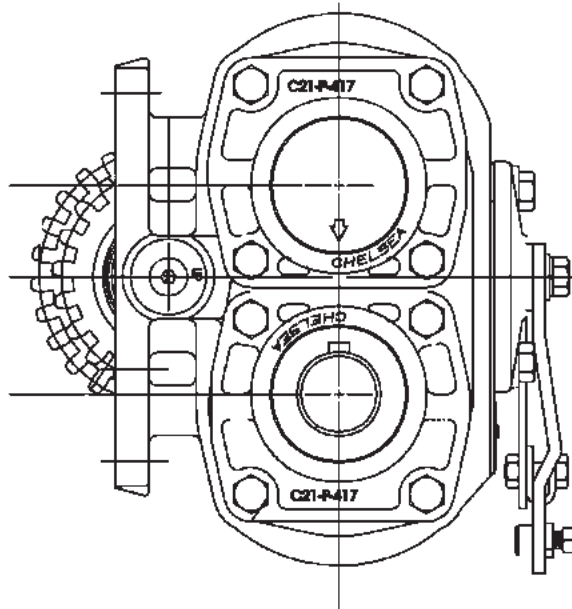
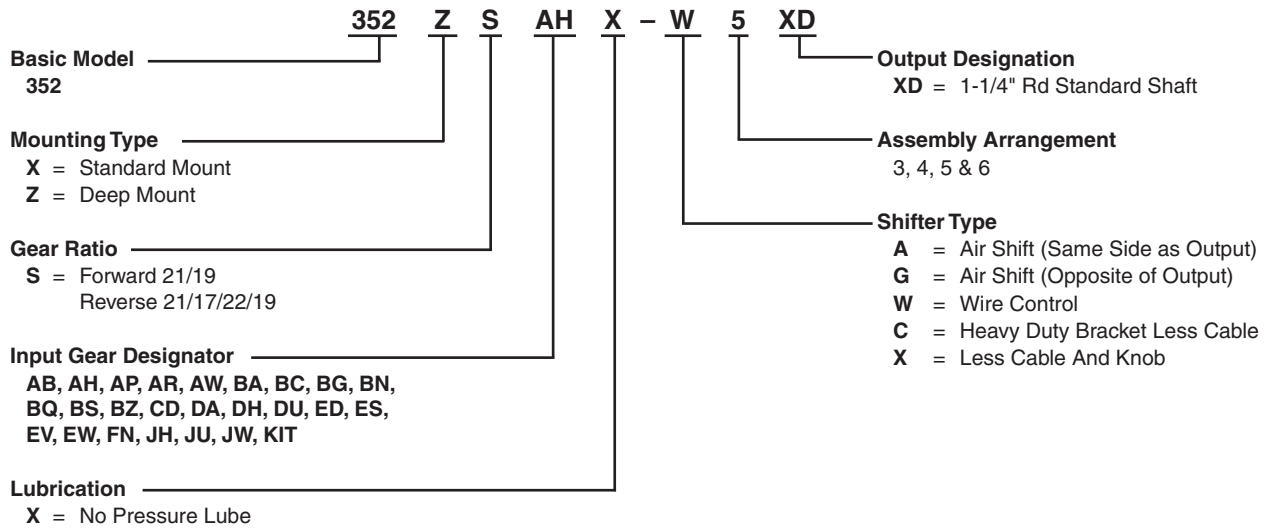

Specifications Chart – 352 Series

352*S

Standard Output Shaft Size	1-1/4" Round w/key
Intermittent Torque Rating (Lbs. ft.)	140
Intermittent Torque Rating (N.m.)	190
Horsepower Rating for Intermittent Service	
At 500 R.P.M. of Output Shaft (HP)	13
At 1000 R.P.M. of Output Shaft (HP)	27
At 500 R.P.M. of Output Shaft (Kw)	10
At 1000 R.P.M. of Output Shaft (Kw)	20
Approximate Weight:	37 lbs. [17 kg]